

~~★~~ PAGE 470 NOT USED ~~★~~

CONTRACT NO. 98950

F.A. RTE.	SECTION	COUNTY	TOTAL SHEETS	SHEET NO.
*	**	WILLIAMSON	917	471

STA.	TO STA.
FED. ROAD DIST. NO.	ILLINOIS FED. AID PROJECT

* I-57, & OLD IL 13 (FAU 9629)
 ** I-6-27B-2, I-1-6HDK-2

TYPICAL SECTION – STAGE 7

- ① EXISTING BITUMINOUS RESURFACING (VARIES 4 1/2" TO 5 1/4")
- ② EXISTING PIPE UNDERDRAINS 4"
- ③ EXISTING BITUMINOUS SHOULDERS
- ④ EXISTING AGGREGATE SHOULDERS TYPE B (WEDGE)
- ⑤ EXISTING AGGREGATE BASE
- ⑥ EXISTING 10" P.C.C. PAVEMENT, 1/2" PARABOLIC CROWN
- ⑦ EXISTING 6" AGGREGATE SUB-BASE (4" ON RAMP "C")
- ⑧ PAVED SHOULDER REMOVAL
- ⑨ BITUMINOUS CONCRETE BINDER COURSE, SUPERPAVE, IL-19.0, N90 9 3/4"
- ⑩ SUB-BASE GRANULAR MATERIAL 6"
- ⑪ TEMPORARY PAINT PAVEMENT MARKING
- ⑫ PIPE UNDERDRAIN REMOVAL
- ⑬ TEMPORARY CONCRETE BARRIER
- ⑭ BITUMINOUS SHOULDERS SUPERPAVE 8"
- ⑮ BITUMINOUS CONCRETE BINDER COURSE, SUPERPAVE, IL-19.0, N90 12"
- ⑯ POLYMERIZED BITUMINOUS CONCRETE BINDER COURSE, SUPERPAVE, IL-19.0, N105 5"
- ⑰ BITUMINOUS SURFACE REMOVAL 5"
- ⑱ RUBBLIZING PORTLAND CEMENT CONCRETE PAVEMENT
- ⑲ AGGREGATE SHOULDERS TYPE A 8"
- ⑳ PAVEMENT REMOVAL
- ㉑ PROCESSING LIME MODIFIED SOILS 12"
- ㉒ BITUMINOUS CONCRETE BINDER COURSE, SUPERPAVE, IL-19.0, N90 11"
- ㉓ BITUMINOUS CONCRETE BINDER COURSE, SUPERPAVE, IL-19.0, N90 7 3/4"
- ㉔ CONCRETE GUTTER, TYPE B
- ㉕ SUB-BASE GRANULAR MATERIAL, TYPE C
- ㉖ POLYMERIZED BITUMINOUS CONCRETE BINDER COURSE, SUPERPAVE, IL-19.0, N105 (VAR)
- ㉗ POLYMERIZED BITUMINOUS CONCRETE SURFACE COURSE, SUPERPAVE, MIX E, N105 1 1/2"
- ㉘ CONCRETE BARRIER, DOUBLE FACE, 42 INCH HEIGHT
- ㉙ TEMPORARY SHEET PILING
- ㉚ BITUMINOUS SHOULDER SUPERPAVE 6 1/2"
- ㉛ STONE RIPRAP, CLASS A3
- ㉜ STEEL PLATE BEAM GUARDRAIL, TYPE A
- ㉝ AGGREGATE SHOULDERS, TYPE B (WEDGE)
- ㉞ BITUMINOUS CONCRETE BINDER COURSE, SUPERPAVE, IL-19.0, N90 12 3/4"
- ㉟ TEMPORARY STEEL PLATE BEAM GUARDRAIL, TYPE A
- ㊱ PIPE UNDERDRAIN 4"
- ㊲ POLYMERIZED BITUMINOUS CONCRETE BINDER COURSE, SUPERPAVE, IL-19.0, N105 2 1/4"
- ㊳ STABILIZED SUB-BASE (VARIABLE DEPTH)
- ㊴ STRIP REFLECTIVE CRACK CONTROL
- ㊵ BITUMINOUS CONCRETE BINDER COURSE, SUPERPAVE, IL-19.0, N90 5"
- ㊶ BITUMINOUS CONCRETE BINDER COURSE, SUPERPAVE, IL-19.0, N90 15"
- ㊷ BITUMINOUS CONCRETE BINDER COURSE, SUPERPAVE, IL-19.0, N90 (VAR)
- ㊸ SUB-BASE GRANULAR MATERIAL 10"
- ㊹ POLYMERIZED BITUMINOUS CONCRETE SURFACE COURSE, SUPERPAVE, MIX E, N105 (VAR.)
- ㊺ BITUMINOUS CONCRETE SURFACE COURSE, SUPERPAVE, MIX C, N70 1 1/2"

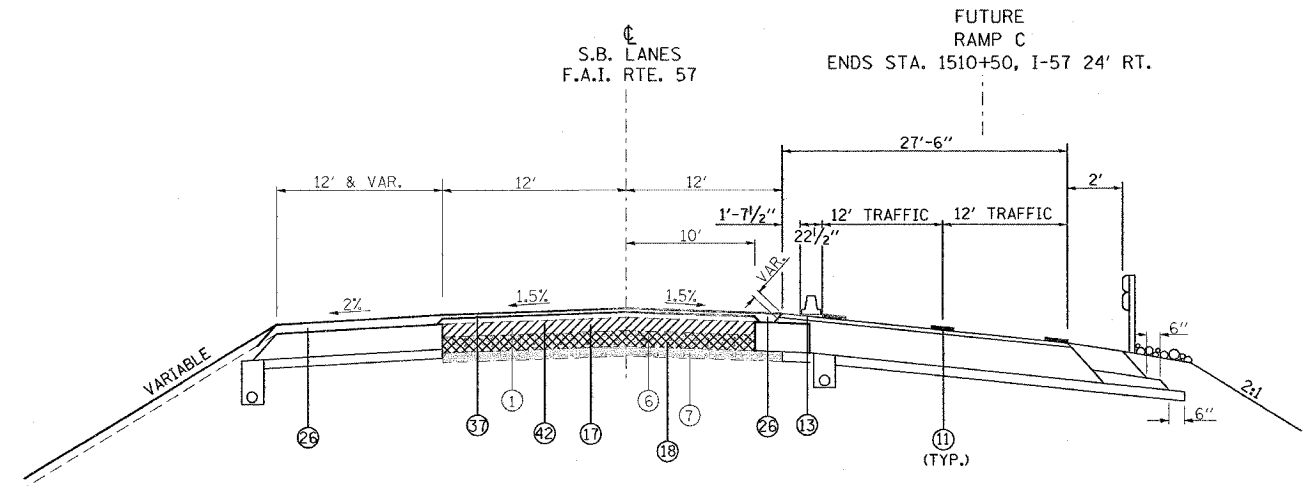

TO BE USED:
 STA. 1511+00 TO STA. 1511+80 SB I-57

STAGE 7 NOTES

NORTHBOUND I-57

- SHIFT TWO LANES OF TRAFFIC TO OUTSIDE.
- INSTALL TEMPORARY CONCRETE BARRIER AND APPLY PAVEMENT MARKINGS USING NIGHT TIME WORK. APPLY TRAFFIC CONTROL STANDARDS 701400, 701401, AND 701411.
- RUBBLIZE AND RESURFACE EXISTING PAVEMENT.
- CONSTRUCT MEDIAN SHOULDER, MEDIAN STORM SEWER, AND THE PERMANENT CONCRETE BARRIER, DOUBLE FACE, 42 INCH HEIGHT.
 -FOR MEDIAN STORM SEWER SEE I-57 MEDIAN STORM SEWER SHEETS
- COMPLETE STAGE 2 BRIDGE REMOVAL AND STAGE 2 BRIDGE CONSTRUCTION.

SOUTHBOUND I-57

- SHIFT TWO LANES OF TRAFFIC TO OUTSIDE.
- INSTALL TEMPORARY CONCRETE BARRIER AND APPLY PAVEMENT MARKINGS USING NIGHT TIME WORK. APPLY TRAFFIC CONTROL STANDARDS 701400, 701401, AND 701411.
- RUBBLIZE AND RESURFACE EXISTING PAVEMENT.
- CONSTRUCT MEDIAN SHOULDER, MEDIAN STORM SEWER, AND THE PERMANENT CONCRETE BARRIER, DOUBLE FACE, 42 INCH HEIGHT.
 -FOR MEDIAN STORM SEWER SEE I-57 MEDIAN STORM SEWER SHEETS
- COMPLETE STAGE 2 BRIDGE REMOVAL AND STAGE 2 BRIDGE CONSTRUCTION.

REVISIONS	
NAME	DATE

ILLINOIS DEPARTMENT OF TRANSPORTATION
FAI-57
STAGE 7
TYPICAL AND NOTES
SHEET 1 OF 16

SCALE: VERT. NONE
 HORIZ. DATE
 DRAWN BY CNH
 CHECKED BY

PLOT DATE = 12/4/2006
 FILE NAME = c:\p\projects\982802\old\13\77stage7.dgn
 PLOT SCALE = 50.0000 / IN.
 USER NAME = hseadon