

F.A. RTE.	SECTION	COUNTY	TOTAL SHEETS	SHEET NO.
*	**	WILLIAMSON	917	529
STA.		TO STA.		
FED. ROAD DIST. NO.		ILLINOIS FED. AID PROJECT		
* I-57, & OLD IL 13 (FAU 9629)				
** (X1-6-2)VB-2, (X1-6)HBK-2				

TYPICAL SECTION - STAGE 7C

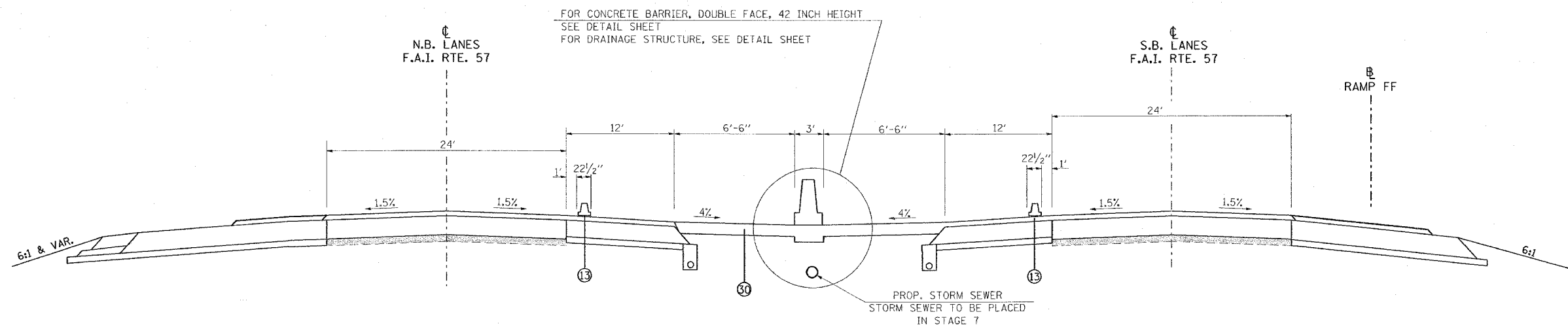

TO BE USED:

STA. 1541+33 TO STA. 1542+33 NB I-57
 STA. 1541+33 TO STA. 1542+33 SB I-57

- | | | |
|-------------------------------------------------------------------------------------------------------------------------------------------------------------------------------------------------------------------------------------------------------------------------------------------------------------------------------------------------------------------------------------------------------------------------------------------------------------------------------------------------------------------------------------------------------------------------------------------------------------------------------------------------------------------------------------------------------------------------------------------------------------------------------------------------------------------------------------------------------------------------------------------------------------------------------------------------------------------------------------------------------------------------------------------------------|--------------------------------------------------------------------------------------------------------------------------------------------------------------------------------------------------------------------------------------------------------------------------------------------------------------------------------------------------------------------------------------------------------------------------------------------------------------------------------------------------------------------------------------------------------------------------------------------------------------------------------------------------------------------------------------------------------------------------------------------------------------------------------------------------------------------------------------------------------------------------------------------------------------------------------------------------------------------------------------------------------------------------------------------------------------------------------------------------------------------------------------------------------------------------------|----------------------------------------------------------------------------------------------------------------------------------------------------------------------------------------------------------------------------------------------------------------------------------------------------------------------------------------------------------------------------------------------------------------------------------------------------------------------------------------|
| <ul style="list-style-type: none"> ① EXISTING BITUMINOUS RESURFACING (VARIES 4 1/2" TO 5 1/4") ② EXISTING PIPE UNDERDRAINS 4" ③ EXISTING BITUMINOUS SHOULDERS ④ EXISTING AGGREGATE SHOULDERS TYPE B (WEDGE) ⑤ EXISTING AGGREGATE BASE ⑥ EXISTING 10" P.C.C. PAVEMENT, 1/2" PARABOLIC CROWN ⑦ EXISTING 6" AGGREGATE SUB-BASE (4" ON RAMP "C") ⑧ PAVED SHOULDER REMOVAL ⑨ BITUMINOUS CONCRETE BINDER COURSE, SUPERPAVE, IL-19.0, N90 9 3/4" ⑩ SUB-BASE GRANULAR MATERIAL 6" ⑪ TEMPORARY PAINT PAVEMENT MARKING ⑫ PIPE UNDERDRAIN REMOVAL ⑬ TEMPORARY CONCRETE BARRIER ⑭ BITUMINOUS SHOULDERS SUPERPAVE 8" ⑮ BITUMINOUS CONCRETE BINDER COURSE, SUPERPAVE, IL-19.0, N90 12" ⑯ POLYMERIZED BITUMINOUS CONCRETE BINDER COURSE, SUPERPAVE, IL-19.0, N105 5" ⑰ BITUMINOUS SURFACE REMOVAL 5" ⑱ RUBBLIZING PORTLAND CEMENT CONCRETE PAVEMENT ⑲ AGGREGATE SHOULDERS TYPE A 8" | <ul style="list-style-type: none"> ⑳ PAVEMENT REMOVAL ㉑ PROCESSING LIME MODIFIED SOILS 12" ㉒ BITUMINOUS CONCRETE BINDER COURSE, SUPERPAVE, IL-19.0, N90 11" ㉓ BITUMINOUS CONCRETE BINDER COURSE, SUPERPAVE, IL-19.0, N90 7 3/4" ㉔ CONCRETE GUTTER, TYPE B ㉕ SUB-BASE GRANULAR MATERIAL, TYPE C ㉖ POLYMERIZED BITUMINOUS CONCRETE BINDER COURSE, SUPERPAVE, IL-19.0, N105 (VAR) ㉗ POLYMERIZED BITUMINOUS CONCRETE SURFACE COURSE, SUPERPAVE, MIX E, N105 1 1/2" ㉘ CONCRETE BARRIER, DOUBLE FACE, 42 INCH HEIGHT ㉙ TEMPORARY SHEET PILING ㉚ BITUMINOUS SHOULDER SUPERPAVE 6 1/2" ㉛ STONE RIPRAP, CLASS A3 ㉜ STEEL PLATE BEAM GUARDRAIL, TYPE A ㉝ AGGREGATE SHOULDERS, TYPE B (WEDGE) ㉞ BITUMINOUS CONCRETE BINDER COURSE, SUPERPAVE, IL-19.0, N90 12 3/4" ㉟ TEMPORARY STEEL PLATE BEAM GUARDRAIL, TYPE A ㊱ PIPE UNDERDRAIN 4" ㊲ POLYMERIZED BITUMINOUS CONCRETE BINDER COURSE, SUPERPAVE, IL-19.0, N105 2 1/4" ㊳ STABILIZED SUB-BASE (VARIABLE DEPTH) ㊴ STRIP REFLECTIVE CRACK CONTROL | <ul style="list-style-type: none"> ㊵ BITUMINOUS CONCRETE BINDER COURSE, SUPERPAVE, IL-19.0, N90 5" ㊶ BITUMINOUS CONCRETE BINDER COURSE, SUPERPAVE, IL-19.0, N90 15" ㊷ BITUMINOUS CONCRETE BINDER COURSE, SUPERPAVE, IL-19.0, N90 (VAR) ㊸ SUB-BASE GRANULAR MATERIAL 10" ㊹ POLYMERIZED BITUMINOUS CONCRETE SURFACE COURSE, SUPERPAVE, MIX E, N105 (VAR.) ㊺ BITUMINOUS CONCRETE SURFACE COURSE, SUPERPAVE, MIX C, N70 1 1/2" |
|-------------------------------------------------------------------------------------------------------------------------------------------------------------------------------------------------------------------------------------------------------------------------------------------------------------------------------------------------------------------------------------------------------------------------------------------------------------------------------------------------------------------------------------------------------------------------------------------------------------------------------------------------------------------------------------------------------------------------------------------------------------------------------------------------------------------------------------------------------------------------------------------------------------------------------------------------------------------------------------------------------------------------------------------------------|--------------------------------------------------------------------------------------------------------------------------------------------------------------------------------------------------------------------------------------------------------------------------------------------------------------------------------------------------------------------------------------------------------------------------------------------------------------------------------------------------------------------------------------------------------------------------------------------------------------------------------------------------------------------------------------------------------------------------------------------------------------------------------------------------------------------------------------------------------------------------------------------------------------------------------------------------------------------------------------------------------------------------------------------------------------------------------------------------------------------------------------------------------------------------------|----------------------------------------------------------------------------------------------------------------------------------------------------------------------------------------------------------------------------------------------------------------------------------------------------------------------------------------------------------------------------------------------------------------------------------------------------------------------------------------|

REVISIONS	
NAME	DATE

ILLINOIS DEPARTMENT OF TRANSPORTATION

**FAI-57
 STAGE 7C
 TYPICAL AND NOTES
 SHEET 2 OF 9**

SCALE: VERT. NONE
 HORIZ. DATE

DRAWN BY CNH
 CHECKED BY

PLOT DATE = 12/5/2006
 FILE NAME = I:\98950\98950.dgn
 PLOT SCALE = 1/8" = 1'-0"
 USER NAME = haddon