

**DETAIL A**

\* Bent bars may be butt welded top and bottom or bottom only. In lieu of fabricated handhole frame as shown, may cut from 2" plate (rolling direction vertical). All cut faces to be ground to ANSI Roughness of 500 μin or less.

\*\* Butt welded joint in post is only allowed for post heights (H) over 20 ft. in length. If used, weld procedure must be preapproved by Engineer and joint shall receive 100% RT or UT (tension criteria) at Contractor's expense.

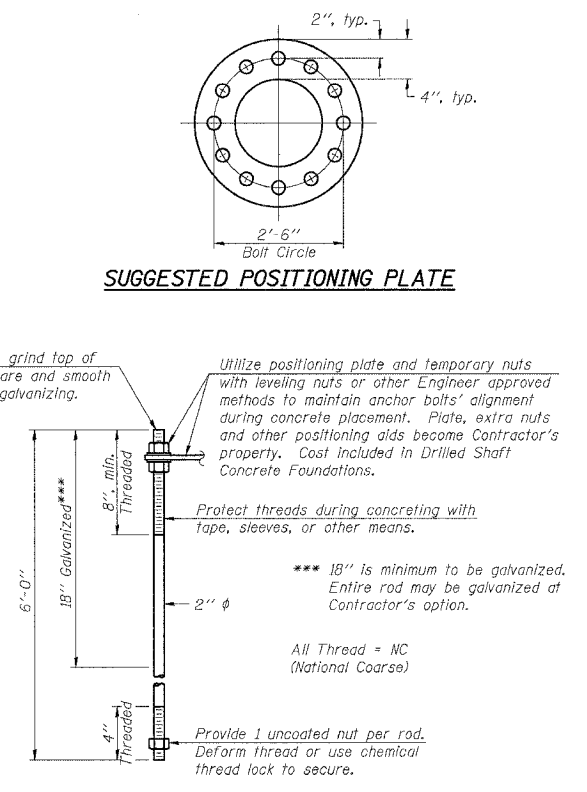
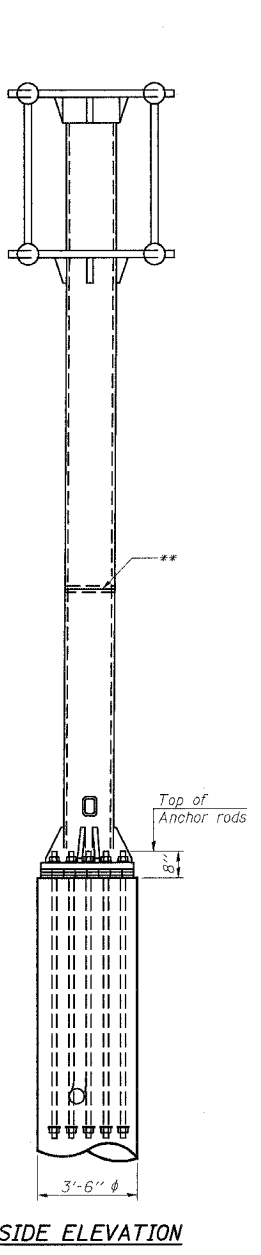

**ANCHOR ROD DETAIL**

Anchor rods shall conform to AASHTO M314 Grade 55 and meet Charpy V-Notch (CVN) energy of 15 lb.-ft. at 10° F. before galvanizing. Galvanize the upper 18" (minimum\*\*\*) and associated M291, Grade A, C or DH heavy hex nuts and hardened washers per AASHTO M232. No welding shall be permitted on rods. Provide an unfinished nut at bottom, a hexagon locknut and washer above base plate and a leveling nut and washer below base plate. Nuts shall each be tightened with 200 lb.-ft. minimum torque against base plate. Before or after threading, but before galvanizing, each anchor rod shall be ultrasonically tested (UT) by a Level II or III inspector, qualified in accord with ANSI guidelines, using a straight beam, 1/2" φ 3.5 mhz. transducer, to insure no rejectable flaws exist in the upper 18" (tension criteria). Cost of testing included in Drilled Shaft Concrete Foundations.

NUMBER	REVISION	DATE

Structure Number	Station	H
9C1001057R53.1	1515+50	22.1

REVISIONS		ILLINOIS DEPARTMENT OF TRANSPORTATION
NAME	DATE	
		<b>CANTILEVER SIGN STRUCTURES</b> <b>TYPE II-C-A &amp; III-C-A TRUSS SUPPORT POST</b> <b>ALUMINUM TRUSS &amp; STEEL POST</b>

PLOT DATE = 12/13/2006  
FILE NAME = c:\pvs\res\13\92282\d13\013p5.dgn  
PLOT SCALE = 50.0000 / 1 IN.  
USER NAME = headen

OSC-A-5 1-7-05

SCALE: VERT. NONE  
HORIZ. DATE  
DRAWN BY CNH  
CHECKED BY