

F.A. RTE.	SECTION	COUNTY	TOTAL SHEETS	SHEET NO.
*	**	WILLIAMSON	917	791
STA.		TO STA.		
FED. ROAD DIST. NO.		ILLINOIS FED. AID PROJECT		
* I-57, & OLD IL 13 (FAU 9629)				
** (X1-6-2)VB-2,(X1-6)HBK-2				

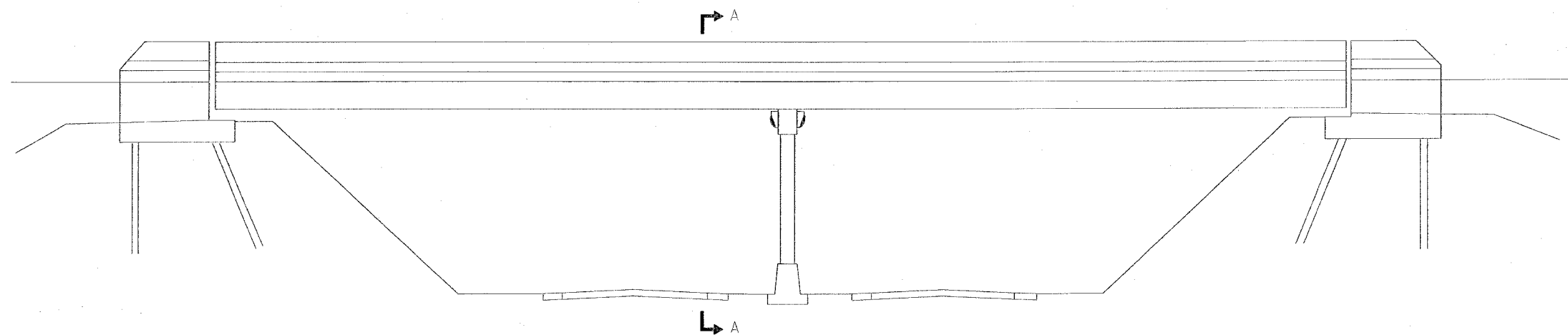

OVERPASS ELEVATION  
(Not to Scale)

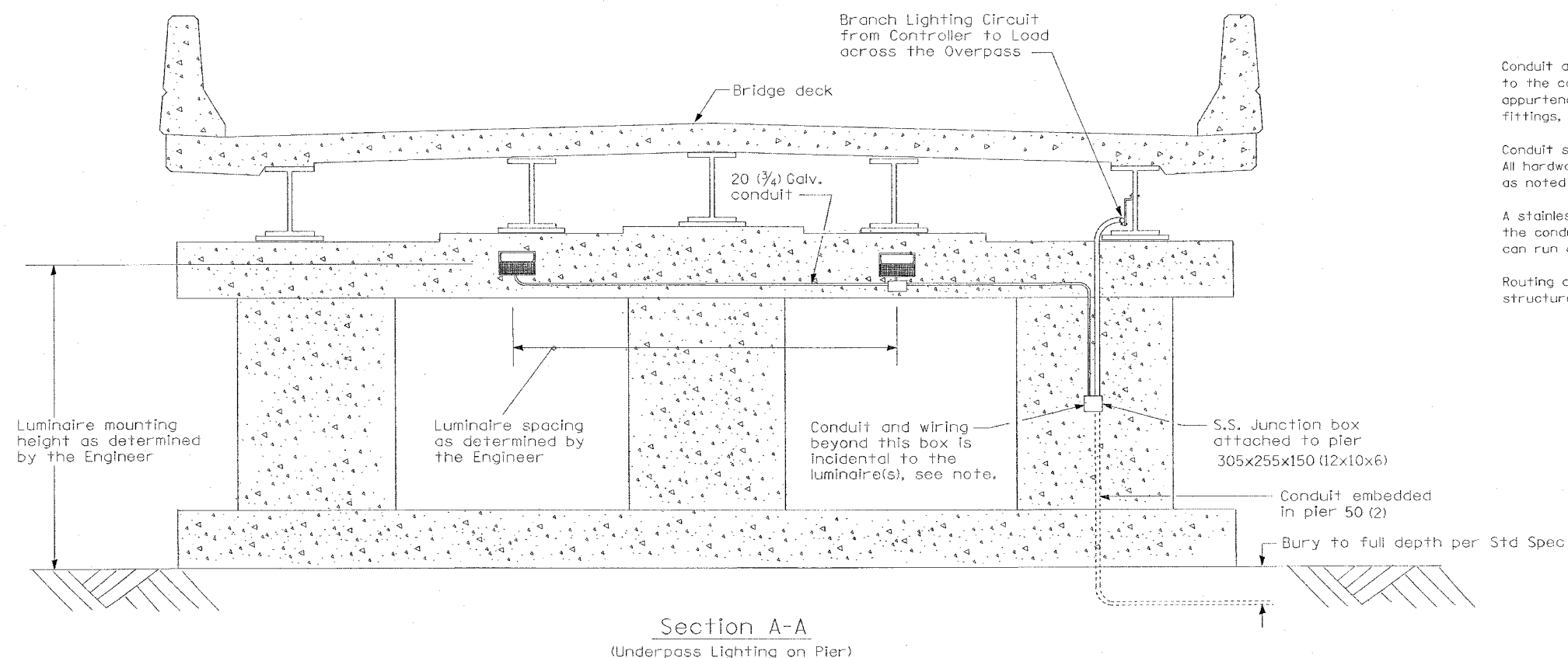

Section A-A  
(Underpass Lighting on Pier)

All dimensions are in millimeters (inches) unless otherwise shown.

GENERAL NOTES

Conduit and wiring to the underpass luminaire(s) shall be incidental to the cost of the underpass luminaire(s). This includes all appurtenances including, but not limited to; straps, clamps, hangers, fittings, attachments, hardware, etc.

Conduit shall be rigid galvanized conduit unless noted otherwise. All hardware shall be stainless steel and all conduit appurtenances, as noted above, shall be hot dip galvanized or stainless steel.

A stainless steel junction box and flex conduit shall be installed in the conduit at any opening in the bridge deck where road salt can run down onto the conduit system.

Routing and method of attachment of the conduit on the bridge structure and across piers shall be as approved by the Engineer.

REVISIONS	
NAME	DATE
Corrected	4/3/06

ILLINOIS DEPARTMENT OF TRANSPORTATION

**DETAILS:  
UNDERPASS LIGHTING  
WITH CENTER PIER**

SCALE: VERT. NONE  
HORIZ. NONE

DRAWN BY CNH  
CHECKED BY LA

LGT019B.M32

PLOT DATE = 10/13/2006  
 FILE NAME = c:\p022822\013\013\013\013.dgn  
 PLOT SCALE = 50.0000 / 1 IN.  
 USER NAME = heshan