

T.R.	SECTION	COUNTY	TOTAL SHEETS	SHEET NO.
318	97-12113-02-BR	HAMILTON	15	15
FED. ROAD DIST. NO. 9		ILLINOIS	CONTRARY CREEK	
PROJECT * BROS-065(036)			CONTRACT * 99280	
LEC JOB #H05ILO10HM				

CURLED END SECTION DETAIL

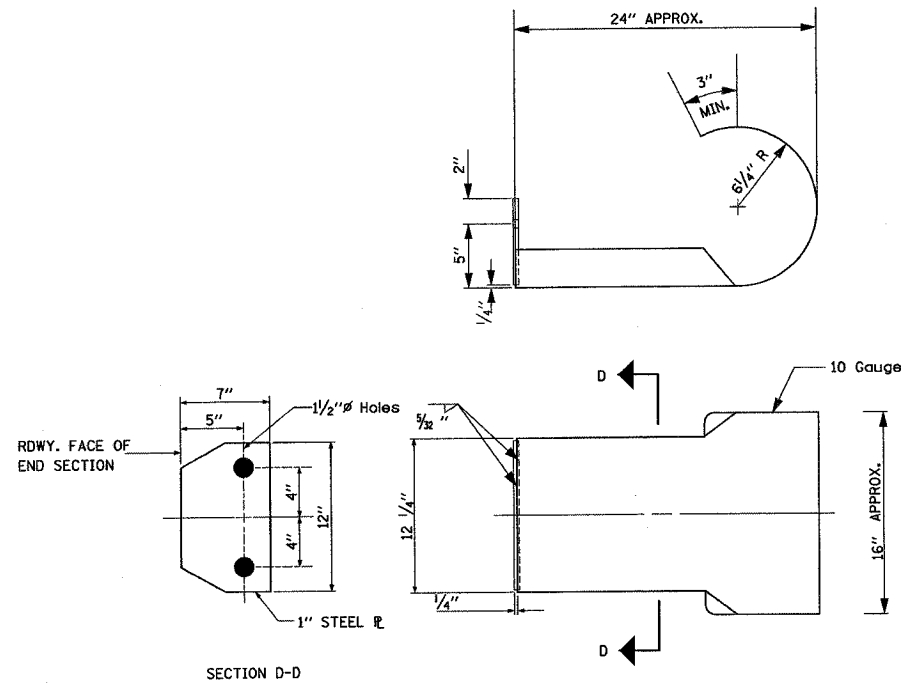

ALL OTHER STEEL SHAPES AND PLATES SHALL CONFORM TO THE REQUIREMENTS OF A.A.S.H.T.O. DESIGNATION M-183 EXCEPT POSTS AND ANGLES SHALL CONFORM TO A.A.S.H.T.O. M-223, GRADE 50.

BOLTS, CAP SCREWS, AND NUTS SHALL CONFORM TO THE REQUIREMENT OF A.S.T.M. DESIGNATION A-307 EXCEPT FOR HIGH STRENGTH BOLTS, NUTS, AND WASHERS NOTED WHICH SHALL CONFORM TO A.A.S.H.T.O. DESIGNATION M-164.

ALL BOLTS, NUTS, CAP SCREWS, WASHERS, AND LOCK WASHERS SHALL BE GALVANIZED IN ACCORDANCE WITH A.A.S.H.T.O. DESIGNATION M-232.

ALL FIELD DRILLED HOLES SHALL BE COATED WITH AN APPROVED ZINC RICH PAINT BEFORE ERRECTION.

STONE RIPRAP DITCH DESIGN

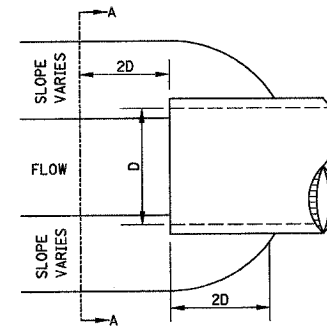

Plan

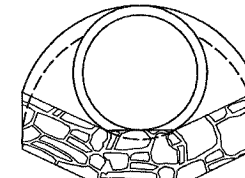

Section A-A

NOTE: FOR PLACEMENT, QUALITY GRADATION AND OTHER MISCELLANEOUS REQUIREMENTS FOR STONE RIPRAP DITCH-SEE SPECIAL PROVISIONS.

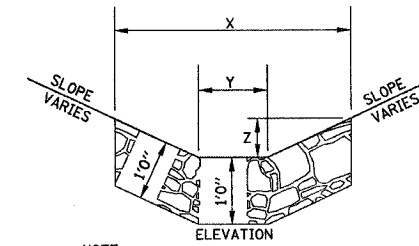

ELEVATION

NOTE:  
BOTTOM OF DITCH

SLOPE

	1 1/2:1	2:1	3:1	
2 FT	X= 5 FT	6 FT	8 FT	
	Y= 2 FT	2 FT	2 FT	
	Z= 1 FT	1 FT	1 FT	
	0.40	0.48	0.62	TON/LIN. FT

	1 1/2:1	2:1	3:1	
3 FT	X= 6 FT	7 FT	9 FT	
	Y= 3 FT	3 FT	3 FT	
	Z= 1 FT	1 FT	1 FT	
	0.48	0.56	0.70	TON/LIN. FT

	1 1/2:1	2:1	3:1	
4 FT	X= 7 FT	8 FT	10 FT	
	Y= 4 FT	4 FT	4 FT	
	Z= 1 FT	1 FT	1 FT	
	0.56	0.64	0.78	TON/LIN. FT