

F.A.P. RTE.	SECTION	COUNTY	TOTAL SHEETS	SHEET NO.
856	01-00170-26-TL	WILL	171	123
STA.		TO STA.		
FED. ROAD DIST. NO.		ILLINOIS	FED. AID PROJECT	
CONTRACT NO: 63570				

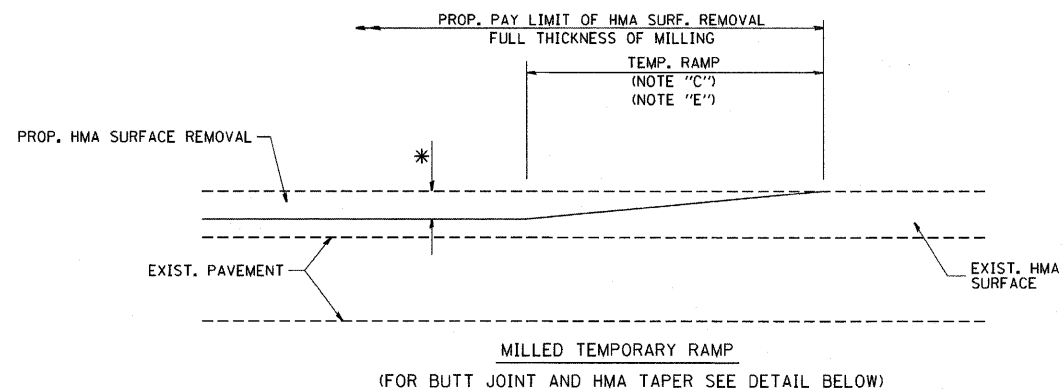

OPTION 1

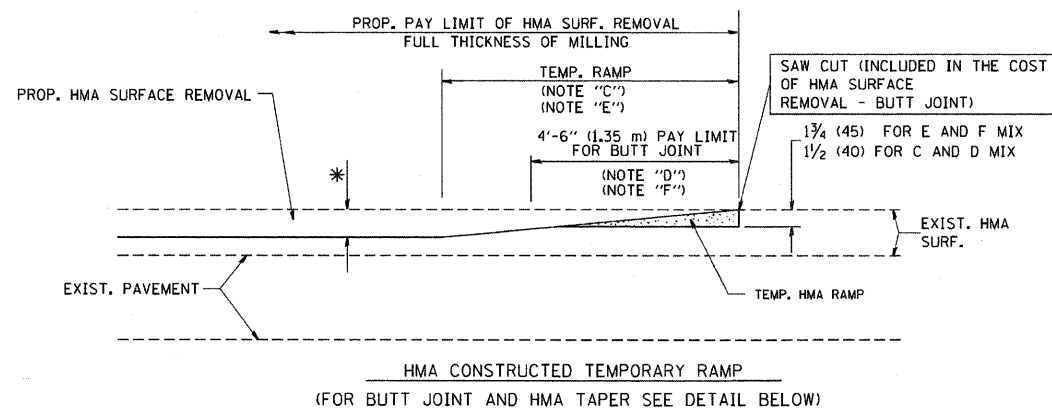

**OPTION 2
TYPICAL TEMPORARY RAMP**

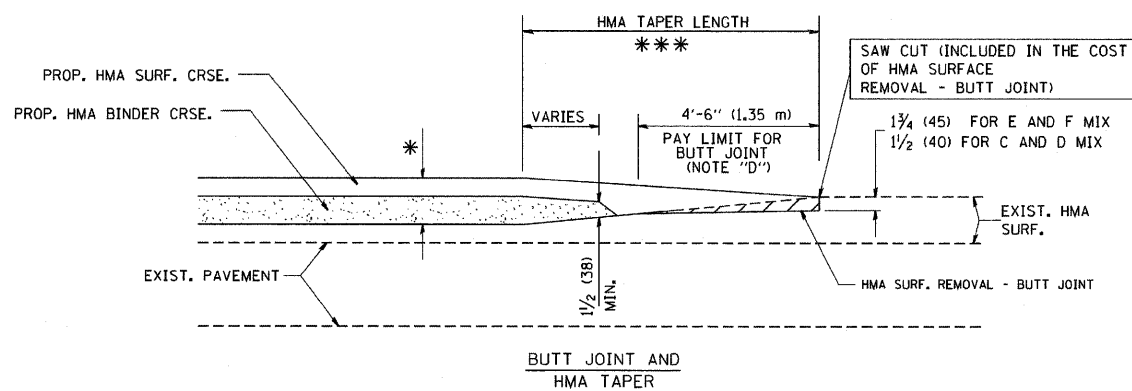

**TYPICAL BUTT JOINT AND HMA TAPER
FOR MILLING AND RESURFACING**

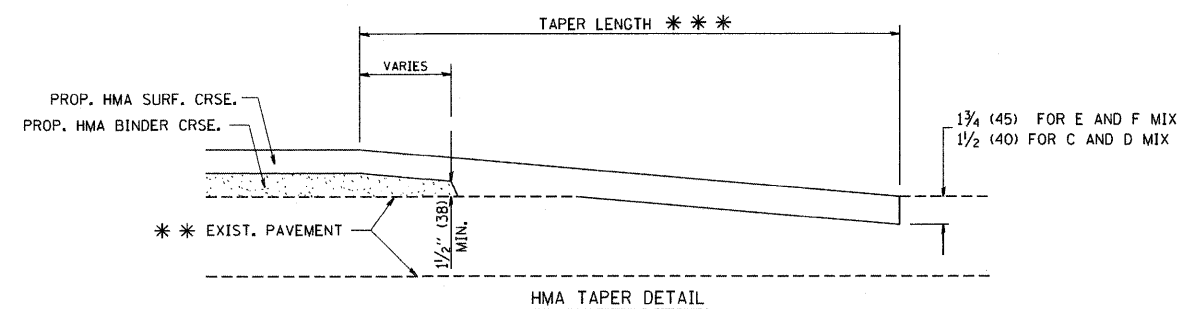
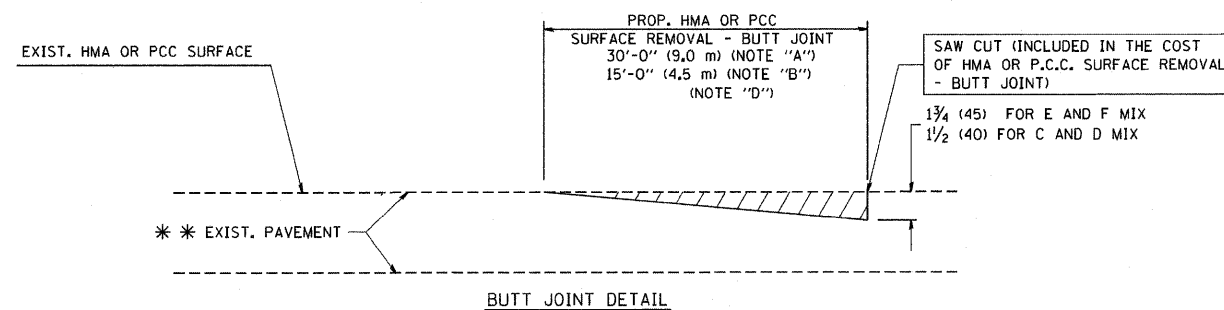

**TYPICAL BUTT JOINT AND HMA TAPER
FOR RESURFACING ONLY**

** PC CONCRETE, HMA OR HMA RESURFACED PAVEMENT.

NOTES

- A: MAINLINE ROADWAYS AND MAJOR SIDE ROADS.
- B: MINOR SIDE ROADS.
- C: THE TEMP. RAMP SHALL BE CONSTRUCTED IMMEDIATELY UPON REMOVAL OF THE EXISTING HMA SURFACE.
- D: THE BUTT JOINT SHALL BE CONSTRUCTED IMMEDIATELY PRIOR TO PLACING THE PROPOSED HMA COURSES.
- E: TAPER THE TEMP. RAMP AT A RATE OF 3'-0" (900 mm) PER 1 INCH (25 mm) OF MILLING THICKNESS.
- F: INSTALLATION AND REMOVAL OF THE 4'-6" (1.35 m) TEMP. RAMP IS INCLUDED IN COST OF HMA SURFACE REMOVAL - BUTT JOINT
- G: SEE ARTICLE 406.08 AND 406.14 OF THE STANDARD SPECIFICATIONS FOR "HMA AND/OR PCC SURFACE REMOVAL, BUTT JOINT".
- * SEE TYPICAL SECTIONS FOR MILLING THICKNESS.
- ** 20'-0" (6.1 m) PER 1 (25) RESURFACING (NOTE "A")
10'-0" (3.0 m) PER 1 (25) RESURFACING (NOTE "B")

BASIS OF PAYMENT:

THE BUTT JOINT WILL BE PAID FOR AT THE CONTRACT UNIT PRICE PER SQUARE YARD (SQUARE METER) FOR "HOT-MIX ASPHALT SURFACE REMOVAL - BUTT JOINT" OR FOR "PORTLAND CEMENT CONCRETE SURFACE REMOVAL - BUTT JOINT".

ALL DIMENSIONS ARE IN INCHES (MILLIMETERS) UNLESS OTHERWISE SHOWN.

BD-32

ILLINOIS DEPARTMENT OF TRANSPORTATION

**BUTT JOINT AND
HMA TAPER
DETAILS**

REVISIONS	
NAME	DATE
M. DE YONG	06-13-90
M. DE YONG	07-03-90
M. DE YONG	03-27-92
R. SHAH	09-09-94
R. SHAH	10-25-94
A. ABBAS	03-21-97
M. GOMEZ	04-06-01
R. BORO	01-01-07

SCALE: NONE

DRAWN BY
CHECKED BY