

STATE OF ILLINOIS
DEPARTMENT OF TRANSPORTATION
DIVISION OF HIGHWAYS

F.A.U. RTE. 1453	SECTION 11-00043-00-LS	COUNTY DU PAGE	TOTAL SHEETS 20	SHEET NO. 1
FED. ROAD DIST. NO. 1		ILLINOIS	FED. AID PROJECT TE-00D1 (872)	
CONTRACT NO. 63663				

PLANS FOR PROPOSED FEDERAL AID PROJECT

FAU 1453 (WEST 22ND STREET)
SPRING ROAD TO SALT CREEK
STREETSCAPE ENHANCEMENTS
SECTION NO: 11-00043-00-LS
PROJECT NO: TE-00D1 (872)
VILLAGE OF OAK BROOK
DUPAGE COUNTY
JOB NO: C-91-501-11

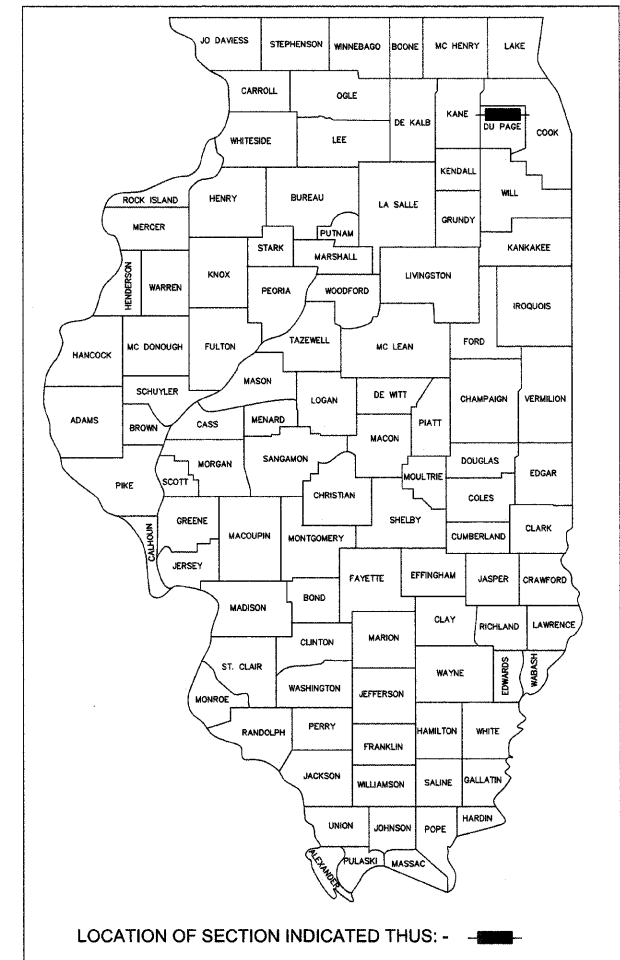

INDEX OF SHEETS

SHEET NO.	SHEET DESCRIPTION
1	COVER SHEET
2	SUMMARY OF QUANTITIES, GENERAL NOTES, AND HIGHWAY STANDARDS
3	EXISTING CONDITIONS
4	TYPICAL SECTIONS
5-6	LAYOUT AND MATERIALS PLAN
7-8	LANDSCAPE PLAN
9	LANDSCAPE DETAILS AND NOTES
10-11	ELECTRICAL PLAN
12	ELECTRICAL DETAILS AND NOTES
13-14	IRRIGATION PLAN
15	IRRIGATION LEGEND AND NOTES
16	IRRIGATION DETAILS
17-20	CONSTRUCTION DETAILS HIGHWAY STANDARDS

TRAFFIC DATA

ADT = 29,700 VPD (2011)
POSTED SPEED LIMIT = 40 MPH
FUNCTIONAL CLASSIFICATION = MINOR ARTERIAL

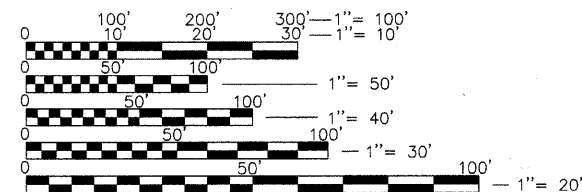

FULL SIZE PLANS HAVE BEEN PREPARED USING STANDARD ENGINEERING SCALES. REDUCED SIZED PLANS WILL NOT CONFORM TO STANDARD SCALES. IN MAKING MEASUREMENTS ON REDUCED PLANS, THE ABOVE SCALES MAY BE USED.



CONTACT JULIE 48 HOURS (2 WORKING DAYS) BEFORE YOU DIG AT 811 OR 800-892-0123 WITH THE FOLLOWING:

COUNTY: DU PAGE
VILLAGE: OAK BROOK
TOWNSHIP: YORK

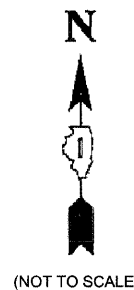

LOCATION MAP
SCALE: 1" = 500'
GROSS LENGTH OF IMPROVEMENT: 3,095 FT (0.586 MILES)
NET LENGTH OF IMPROVEMENT: 3,095 FT (0.586 MILES)

PROJECT BEGINS
STA 2106+83.00

EXISTING STRUCTURE NOS. 022-9901
022-9941
022-9942

EXISTING STRUCTURE NO. 022-0084

PROJECT ENDS
STA 2137+78.00

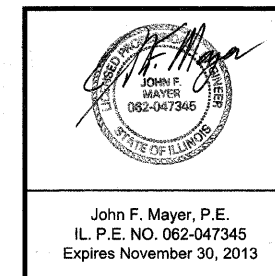

STATE OF ILLINOIS
DEPARTMENT OF TRANSPORTATION
DIVISION OF HIGHWAYS

APPROVED 12/16 2011
[Signature]
VILLAGE REPRESENTATIVE

PASSED January 5 2012
[Signature]
DISTRICT 11 ENGINEER OF LOCAL ROADS & STREETS

RELEASING FOR BID
BASED ON LIMITED
REVIEW JANUARY 6, 2012
[Signature]
DEPUTY DIRECTOR OF HIGHWAYS, REGION ONE ENGINEER

PRINTED BY THE AUTHORITY
OF THE STATE OF ILLINOIS

PROGRAM AND OFFICE ENGINEER: CHARLES F. RIDDLER, P.E. 847-705-4406 SCHAUMBURG, IL

HIGHWAY STANDARDS

701601-07	URBAN LANE CLOSURE, MULTILANE, 1W OR 2W WITH NONTRAVERSABLE MEDIAN
701606-08	URBAN LANE CLOSURE, MULTILANE, 2W WITH MOUNTABLE MEDIAN
701901-02	TRAFFIC CONTROL DEVICES
000001-06	STANDARD SYMBOLS, ABBREVIATIONS AND PATTERNS

CONSTRUCTION SEQUENCING / TRAFFIC CONTROL NOTES

1. THE CONTRACTOR SHALL NOTIFY THE ENGINEER AT LEAST 72 HOURS IN ADVANCE OF BEGINNING WORK.
2. SPECIAL ATTENTION IS CALLED TO TRAFFIC REGULATION. TWO-WAY TRAFFIC SHALL BE MAINTAINED AT ALL TIMES ON ALL ROADWAYS. CONTRACTOR SHALL FOLLOW ALL APPLICABLE STATE TRAFFIC REGULATIONS SHOWN ON STANDARD 701601-07 AND PROVIDE FLAGMEN DURING CONSTRUCTION ACTIVITIES AS NEEDED TO MAINTAIN TWO-WAY TRAFFIC.
3. CONTRACTOR TO HAVE LIMITED ACCESS FOR STORAGE OF EQUIPMENT AND/OR MATERIALS. STAGING OF EQUIPMENT AND/OR MATERIALS WITHIN RIGHT OF WAYS (R.O.W.) SHALL BE GRANTED ON A LIMITED BASIS TO ACCOMMODATE DAILY CONSTRUCTION ACTIVITIES WITH PRIOR APPROVAL BY THE ENGINEER. OVERNIGHT STORAGE IN R.O.W. IS PROHIBITED. CONTRACTOR MAY STORE MATERIALS AND EQUIPMENT AT THE VILLAGE OF OAK BROOK PUBLIC WORKS YARD LOCATED AT 3003 JORIE BOULEVARD WITH PRIOR APPROVAL FROM THE PUBLIC WORKS DIRECTOR (TEL. NO. 630-368-5270). STORAGE AT THE PUBLIC WORKS YARD IS AT CONTRACTOR'S RISK.
4. SIDEWALK CLOSURES SHALL BE GRANTED ON A LIMITED BASIS TO ACCOMMODATE DAILY CONSTRUCTION ACTIVITIES WITH PRIOR APPROVAL BY THE ENGINEER. SIDEWALK CLOSURES, IF NECESSARY, SHALL BE LIMITED TO ONE SIDE OF THE STREET AT A TIME. CONTRACTOR SHALL FOLLOW IDOT STANDARD 701801-05 TO REDIRECT PEDESTRIAN TRAFFIC ACCORDINGLY.
5. DAILY LANE CLOSURES WILL BE ALLOWED ONLY ON WEEKDAYS BETWEEN THE HOURS OF 9:00 AM AND 3:00 PM. TRAFFIC CONTROL SHALL BE IN ACCORDANCE WITH IDOT HIGHWAY STANDARDS 701901-02, 701801-05, AND 701601-07.

GENERAL NOTES

1. VERIFY SITE CONDITIONS AND INFORMATION ON DRAWINGS. PROMPTLY REPORT ANY CONCEALED CONDITIONS, MISTAKES, DISCREPANCIES OR DEVIATIONS FROM THE INFORMATION SHOWN IN THE CONTRACT DOCUMENTS. THE DEPARTMENT IS NOT RESPONSIBLE FOR UNAUTHORIZED CHANGES OR EXTRA WORK REQUIRED TO CORRECT UNREPORTED DISCREPANCIES.
2. CONTRACTOR TO PROVIDE FOR AT LEAST ONE LANE OF TRAFFIC BOTH EAST-BOUND AND WEST-BOUND ON 22ND STREET AT ALL TIMES DURING CONSTRUCTION. ALL WORK ZONE TRAFFIC CONTROLS WILL CONFORM TO IDOT SECTION 700 WORK ZONE TRAFFIC CONTROL STANDARDS. OVERNIGHT LANE CLOSURES ARE PROHIBITED UNLESS WRITTEN PERMISSION IS OBTAINED FROM THE ENGINEER. SEE TRAFFIC CONTROL PLANS FOR MORE DETAILS.
3. THE CONTRACTOR WILL BE REQUIRED TO DISPOSE OF ALL MATERIALS EXCAVATED OR REMOVED DUE TO CONSTRUCTION OPERATIONS. ALL EXCESS EXCAVATED MATERIAL SHALL BE REMOVED FROM SITE ON THE DAY IT IS EXCAVATED. HAULING OR TRUCKING THE MATERIAL TO LOCATIONS, SHALL BE PROVIDED BY THE CONTRACTOR, OUTSIDE THE LIMITS OF IMPROVEMENT. THIS WORK SHALL BE INCLUDED IN THE COST OF THE REMOVED ITEMS.
4. ALL SAW CUTS REQUIRED FOR REMOVAL ITEMS SHALL BE INCLUDED IN THE COST OF THAT ITEM. ALL SAW CUTS FOR PROPOSED ITEMS SHALL BE INCLUDED IN THE COST OF THAT ITEM.
6. VILLAGE OF OAK BROOK WILL PROVIDE THE CONTRACTOR WITH WATER AND WATER METER, AND BATHROOM FACILITIES AT THE PUBLIC WORKS YARD LOCATED AT 3003 JORIE BOULEVARD.
7. THE RESIDENT ENGINEER SHALL CONTACT THE TRAFFIC CONTROL SUPERVISOR AT 847-705-4407 A MINIMUM OF 72 HOURS PRIOR TO THE PLACEMENT OF ANY TEMPORARY TRAFFIC CONTROL DEVICES.



DESIGNED - MEU	REVISED - 01-03-12
DRAWN - BLG	REVISED -
CHECKED - TCK	REVISED -
DATE - 12-19-11	REVISED -

NOTE:
BOXED NOTES INDICATE ITEMS OF WORK THAT ARE INCLUDED IN THE COST OF ANOTHER PAY ITEM.

SUMMARY OF QUANTITIES

ITEM	DESCRIPTION	UNIT	0031 TOTAL QUANTITY
20200100	EARTH EXCAVATION	CU YD	788
21101505	TOPSOIL EXCAVATION AND PLACEMENT	CU YD	394
* 21101800	TOPSOIL FURNISH AND PLACE, VARIABLE DEPTH	SQ YD	1,350
* 25000400	NITROGEN FERTILIZER NUTRIENT	POUND	10
* 25000500	PHOSPHORUS FERTILIZER NUTRIENT	POUND	10
* 25000600	POTASSIUM FERTILIZER NUTRIENT	POUND	10
* 25200100	SODDING, SALT TOLERANT	SQ YD	1,000
* 25200200	SUPPLEMENTAL WATERING	UNIT	6
35101400	AGGREGATE BASE COURSE, TYPE B	TON	150
60100080	FRENCH DRAINS	CU YD	10
60100085	GEOTECHNICAL FABRIC FOR FRENCH DRAINS	SQ YD	63
60109510	PIPE UNDERDRAINS, FABRIC LINED TRENCH 4"	FOOT	1,867
60603451	PRECAST CONCRETE CURB	FOOT	1,140
67100100	MOBILIZATION	L SUM	1
70102630	TRAFFIC CONTROL AND PROTECTION, STANDARD 701601	L SUM	1
70102640	TRAFFIC CONTROL AND PROTECTION, STANDARD 701801	L SUM	1
* 81028210	UNDERGROUND CONDUIT, GALVANIZED STEEL, 2 1/2" DIA.	FOOT	286
* 81603035	UNIT DUCT, 600V, 2-1C NO.6, 1/C NO.6 GROUND, (XLP-TYPE USE), 1" DIA. POLYETHYLENE	FOOT	505
* 89502200	MODIFY EXISTING CONTROLLER	EACH	2
* A2004515	TREE, GINKGO BILOBA AUTUMN GOLD (AUTUMN GOLD GINKGO), 3" CALIPER, BALLED AND BURLAPPED	EACH	4
* A2004568	TREE, GINKGO BILOBA MAGYAR ARISTOCRAT (MAGYAR ARISTOCRAT GINKGO), TREE FORM, 3" CALIPER BALLED AND BURLAPPED	EACH	4

ITEM	DESCRIPTION	UNIT	0031 TOTAL QUANTITY
* A2018720	TREE, ULMUS CARPINIFOLIA MORTON, (ACCOLADE ELM), 2-1/2" CALIPER, BALLED AND BURLAPPED	EACH	6
* B2006168	TREE, SYRINGA PEKINENSIS MORTON (CHINA SNOW PEKING LILAC), 7' HEIGHT, CLUMP FORM, BALLED AND BURLAPPED	EACH	16
* C2003424	SHRUB, HYDRANGEA ARBORESCENS ANNABELLE (ANNABELLE SMOOTH HYDRANGEA), 2' HEIGHT CONTAINER	EACH	158
* C2005224	SHRUB, POTENTILLA FRUTICOSA MCKAY'S WHITE (MCKAY'S WHITE BUSH CINQUEFOIL), 2' HEIGHT CONTAINER	EACH	74
* C2012772	SHRUB, VIBURNUM PRUNIFOLIUM (BLACKHAW VIBURNUM), 6' HEIGHT, BALLED AND BURLAPPED	EACH	10
* C2C06402	SHRUB, ROSA AMBER ROSE (AMBER ROSE FLOWER CARPET ROSE), 24" HEIGHT, CONTAINER	EACH	119
* D2015401	EVERGREEN, JUNIPERUS CHINENSIS KALLAYS COMPACTA, (KALLAY COMPACT JUNIPER), 24" WIDTH, BALLED AND BURLAPPED	EACH	25
* K0012990	PERENNIAL PLANTS, ORNAMENTAL TYPE, GALLON POT	UNIT	32.06
* K1001988	IRRIGATION SYSTEM SPECIAL	L SUM	1
* K1005481	SHREDDED BARK MULCH 3"	SQ YD	1,340
* X0326146	SOIL CONDITIONER	SQ YD	1,340
* X0326357	ROADWAY LIGHTING MODIFICATIONS	L SUM	1
X4240430	PORTLAND CEMENT CONCRETE SIDEWALK 5 INCH, SPECIAL	SQ FT	7,285
X4240460	PORTLAND CEMENT CONCRETE SIDEWALK 8 INCH, SPECIAL	SQ FT	160
* X5620035	WATER SERVICE CONNECTION, 1 1/2"	EACH	1
XX000541	EXPLORATORY EXCAVATION	CU YD	5
XX003668	PRE-CONSTRUCTION VIDEO TAPING	L SUM	1
Z0013798	CONSTRUCTION LAYOUT	L SUM	1
Z0017400	DRAINAGE & UTILITY STRUCTURES TO BE ADJUSTED	EACH	3

* INDICATES SPECIALTY ITEMS

STATE OF ILLINOIS
DEPARTMENT OF TRANSPORTATION

SUMMARY OF QUANTITIES, GENERAL NOTES,
AND HIGHWAY STANDARDS

SCALE: N/A

PROJECT - 03-0745-008

F.A.U. RTE	SECTION	COUNTY	TOTAL SHEETS	SHEET NO.
1453	11-00043-00-LS	DUPAGE	20	2
CONTRACT 63663				
FED. ROAD DIST. NO. 1 ILLINOIS FED. AID PROJECT TE-001 (872)				

J:\PROJECTS\700\5\0745-VILLAGE OF OAK BROOK\008-22ND STREET ITEP ENHANCEMENTS\PH GRAPHICS\05-00-00\02-QUANTITIES-NOTES.DWG 2
 Plotted: 1/4/2012 12:27 PM By: KING
 Copyright © 2012, By: Hitchcock Design Group

J:\PROJECTS\700\S\0745-VILLAGE OF OAK BROOK\008-22ND STREET TIEP ENHANCEMENTS\H GRAPHICS\05-DD-CD\05-EXISTING CONDITIONS.DWG 3
 Plotted: 1/4/2012 10:42 AM By: TKING
 Copyright © 2012, By Hitchcock Design Group

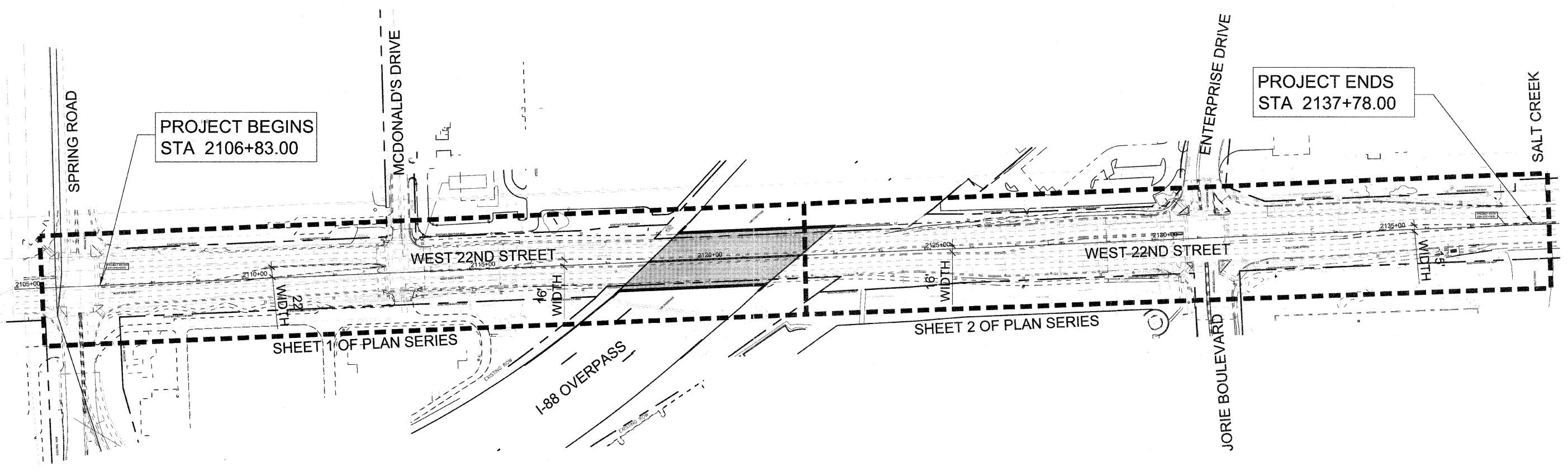

DESIGNED - MEU	REVISED - 01-03-12
DRAWN - BLG	REVISED -
CHECKED - TCK	REVISED -
DATE - 12-19-11	REVISED -

STATE OF ILLINOIS
 DEPARTMENT OF TRANSPORTATION

SCALE: 1" = 150'		PROJECT - 03-0745-008	STA. 2106+83.00 TO STA. 2137+78.00
------------------	--	-----------------------	------------------------------------

F.A.U. RTE.	SECTION	COUNTY	TOTAL SHEETS	SHEET NO.
1453	11-00043-00-LS	DUPAGE	20	3
CONTRACT 63663				
FED. ROAD DIST. NO. 1	ILLINOIS	FED. AID PROJECT	TE-001 (872)	

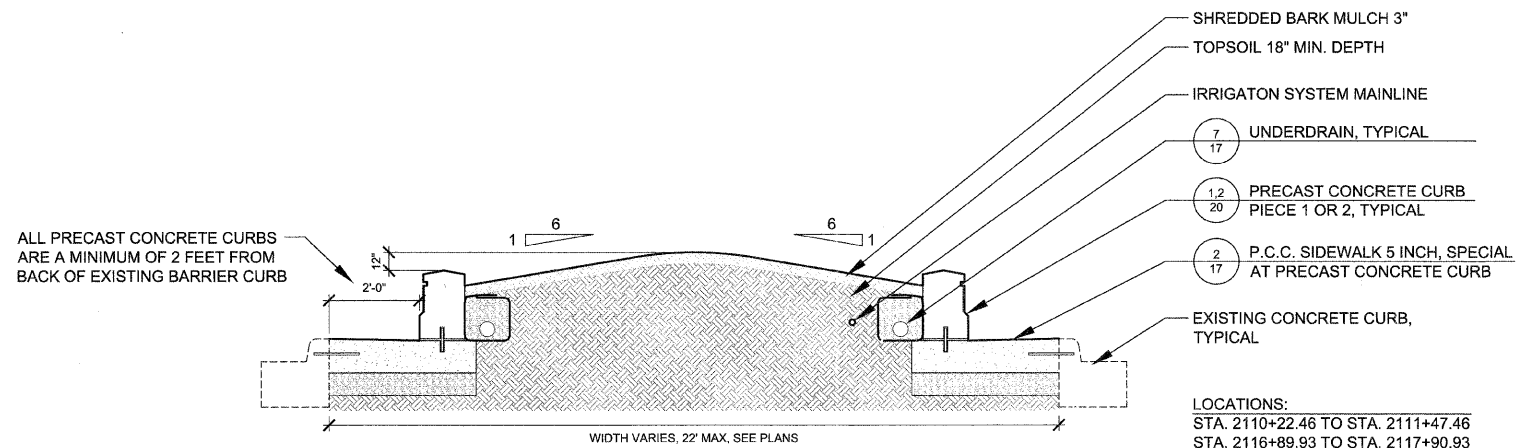

1 PROPOSED TYPICAL SECTION A
SCALE: 1/2" = 1'-0"

LOCATIONS:
 STA. 2110+22.46 TO STA. 2111+47.46
 STA. 2116+89.93 TO STA. 2117+90.93
 STA. 2123+28.37 TO STA. 2124+29.37
 STA. 2125+92.27 TO STA. 2126+93.27
 STA. 2135+27.20 TO STA. 2136+28.20

D-MEDIAN PROFILE A

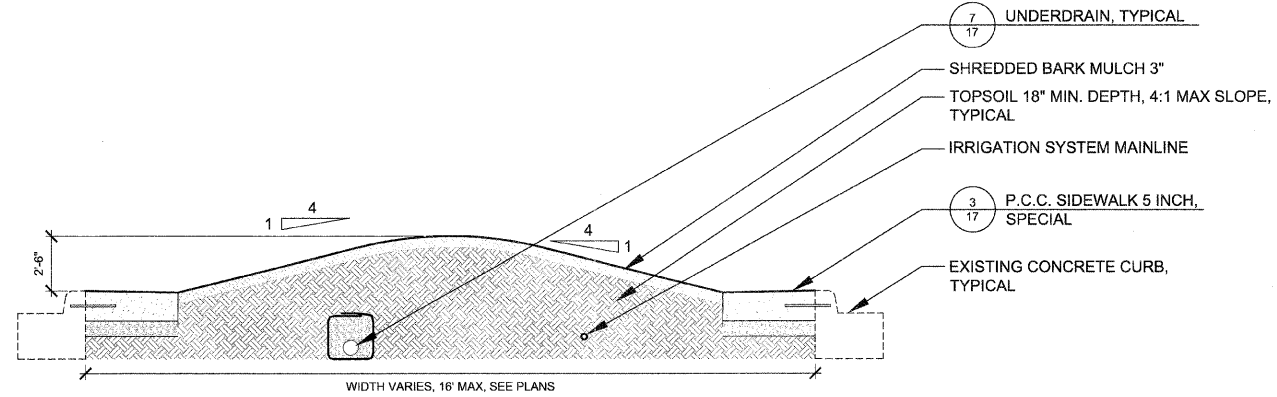

2 PROPOSED TYPICAL SECTION B
SCALE: 1/2" = 1'-0"

LOCATION:
 STA. 2124+2937 TO STA. 2125+92.27

D-MEDIAN PROFILE B

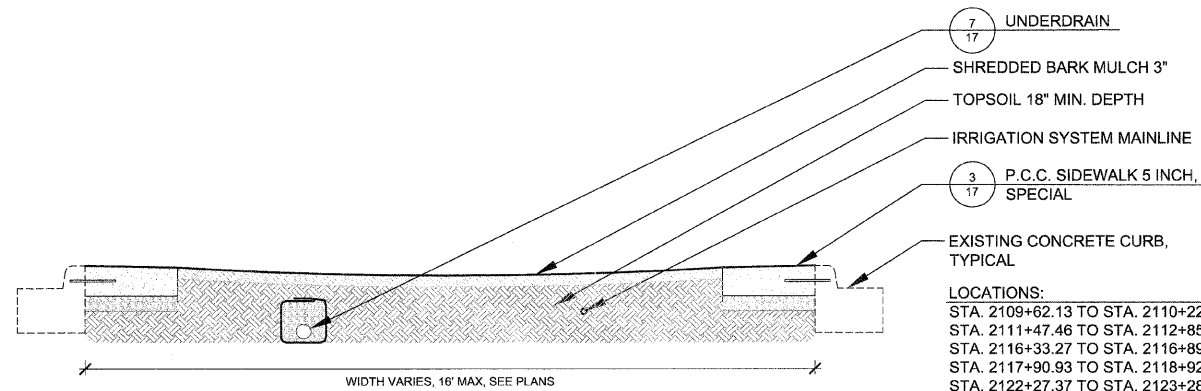

3 PROPOSED TYPICAL SECTION C
SCALE: 1/2" = 1'-0"

LOCATIONS:
 STA. 2109+62.13 TO STA. 2110+22.46
 STA. 2111+47.46 TO STA. 2112+85.83
 STA. 2116+33.27 TO STA. 2116+89.93
 STA. 2117+90.93 TO STA. 2118+92.62
 STA. 2122+27.37 TO STA. 2123+28.37
 STA. 2126+93.27 TO STA. 2127+56.03
 STA. 2134+84.95 TO STA. 2135+27.20
 STA. 2136+28.20 TO STA. 2136+75.45

D-MEDIAN PROFILE C

J:\PROJECTS\700\S\0745-VILLAGE OF OAK BROOK\008-22ND STREET TEP ENHANCEMENTS\H GRAPHICS\05-DD-00\04-TYPICAL SECTIONS.DWG 4
 Plotted: 1/17/2012 10:35 AM By: TRING
 Copyright © 2012, By Hitchcock Design Group



DESIGNED - MEU	REVISED - 01-03-12
DRAWN - BLG	REVISED -
CHECKED - TCK	REVISED -
DATE - 12-19-11	REVISED -

STATE OF ILLINOIS
 DEPARTMENT OF TRANSPORTATION

TYPICAL SECTIONS

SCALE: AS SHOWN

PROJECT - 03-0745-008

F.A.U. RTE.	SECTION	COUNTY	TOTAL SHEETS	SHEET NO.
1453	11-00043-00-LS	DUPAGE	20	4
CONTRACT 63663				
FED. ROAD DIST. NO. 1 ILLINOIS FED. AID PROJECT TE-001 (872)				

J:\PROJECTS\700\S\0745-VILLAGE OF OAK BROOK\008-22ND STREET IMP ENHANCEMENTS\H GRAPHICS\05-DD-00\05-06-LAYOUT AND MATERIALS.DWG 5
 Plotted: 1/4/2012 10:21 AM By: T KING
 Copyright © 2012, By Hitchcock Design Group

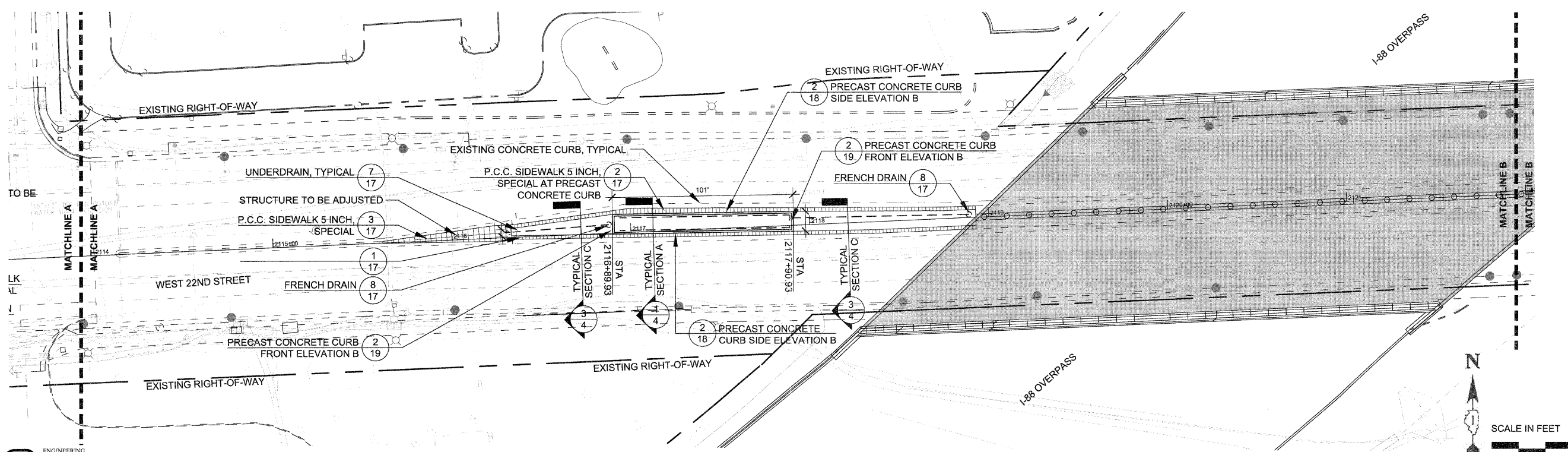
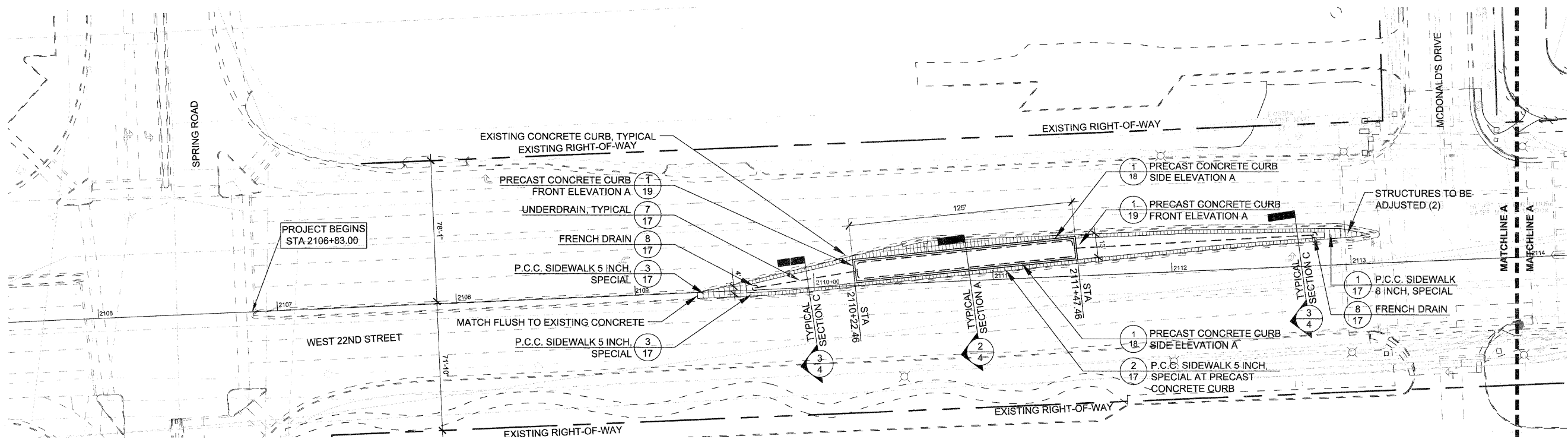

DESIGNED - MEU	REVISED - 01-03-12
DRAWN - BLG	REVISED -
CHECKED - TCK	REVISED -
DATE - 12-19-11	REVISED -

**STATE OF ILLINOIS
DEPARTMENT OF TRANSPORTATION**

LAYOUT AND MATERIALS PLAN

SCALE: 1" = 30'
 PROJECT - 03-0745-008 STA. 2105+83.00 TO STA. 2122+83.00

F.A.U. RTE.	SECTION	COUNTY	TOTAL SHEETS	SHEET NO.
1453	11-00043-004-S	DUPAGE	20	5
CONTRACT 63663		FED. ROAD DIST. NO. 1 ILLINOIS FED. AID PROJECT TE-001(872)		

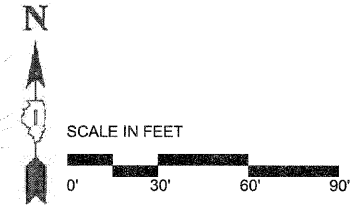

J:\PROJECTS\7005\0745-VILLAGE OF OAK BROOK\008-22ND STREET ITEP ENHANCEMENTS\1- GRAPHICS\05-DD-CD\05-08-LAYOUT AND MATERIALS.DWG 6
 Plotted: 12/15/2011 4:07 PM By: TKING
 Copyright © 2011, By: Hitchcock Design Group

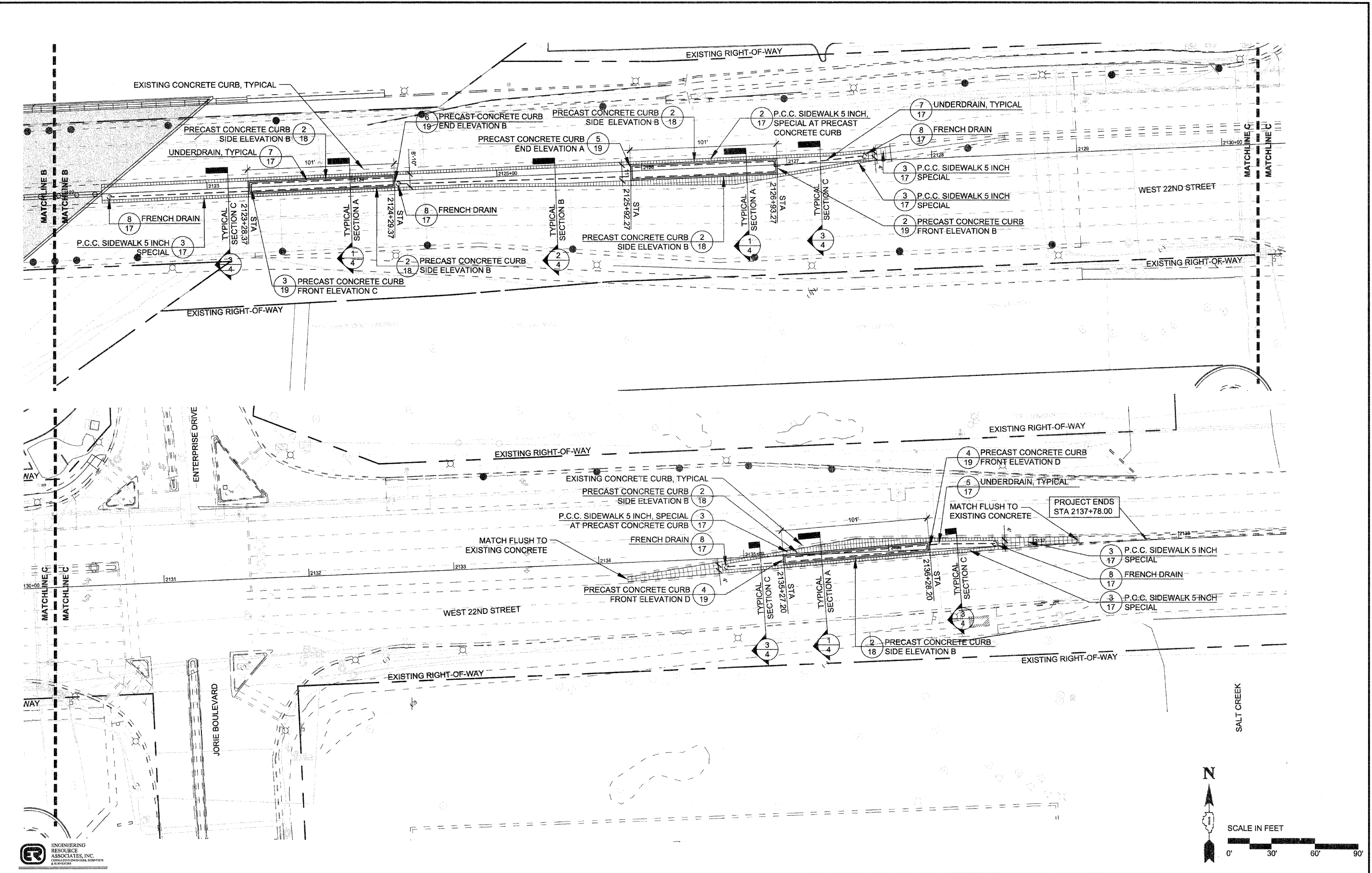

DESIGNED - MEU	REVISED -
DRAWN - BLG	REVISED -
CHECKED - TCK	REVISED -
DATE - 12-19-11	REVISED -

STATE OF ILLINOIS
 DEPARTMENT OF TRANSPORTATION

LAYOUT AND MATERIALS PLAN

SCALE: 1" = 30'
 PROJECT - 03-0745-008 STA. 2122+83.00 TO STA. 2138+83.00

F.A.U. RTE 1453	SECTION 11-00043-00-LS	COUNTY DUPAGE	TOTAL SHEETS 20	SHEET NO. 6
CONTRACT 63663		ILLINOIS FED. AID PROJECT TE-0001 (872)		

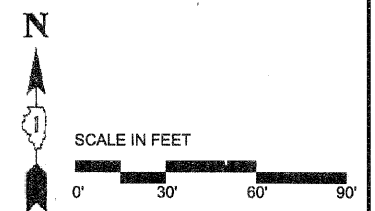

J:\PROJECTS\700\S\0745-VILLAGE OF OAK BROOK\008-22ND STREET ITEP ENHANCEMENTS\H GRAPHICS\05-DD-CD\07-08-LANDSCAPE.DWG 7
 Plotted: 12/15/2011 4:56 PM By: TKING
 Copyright © 2011, By: Hitchcock Design Group

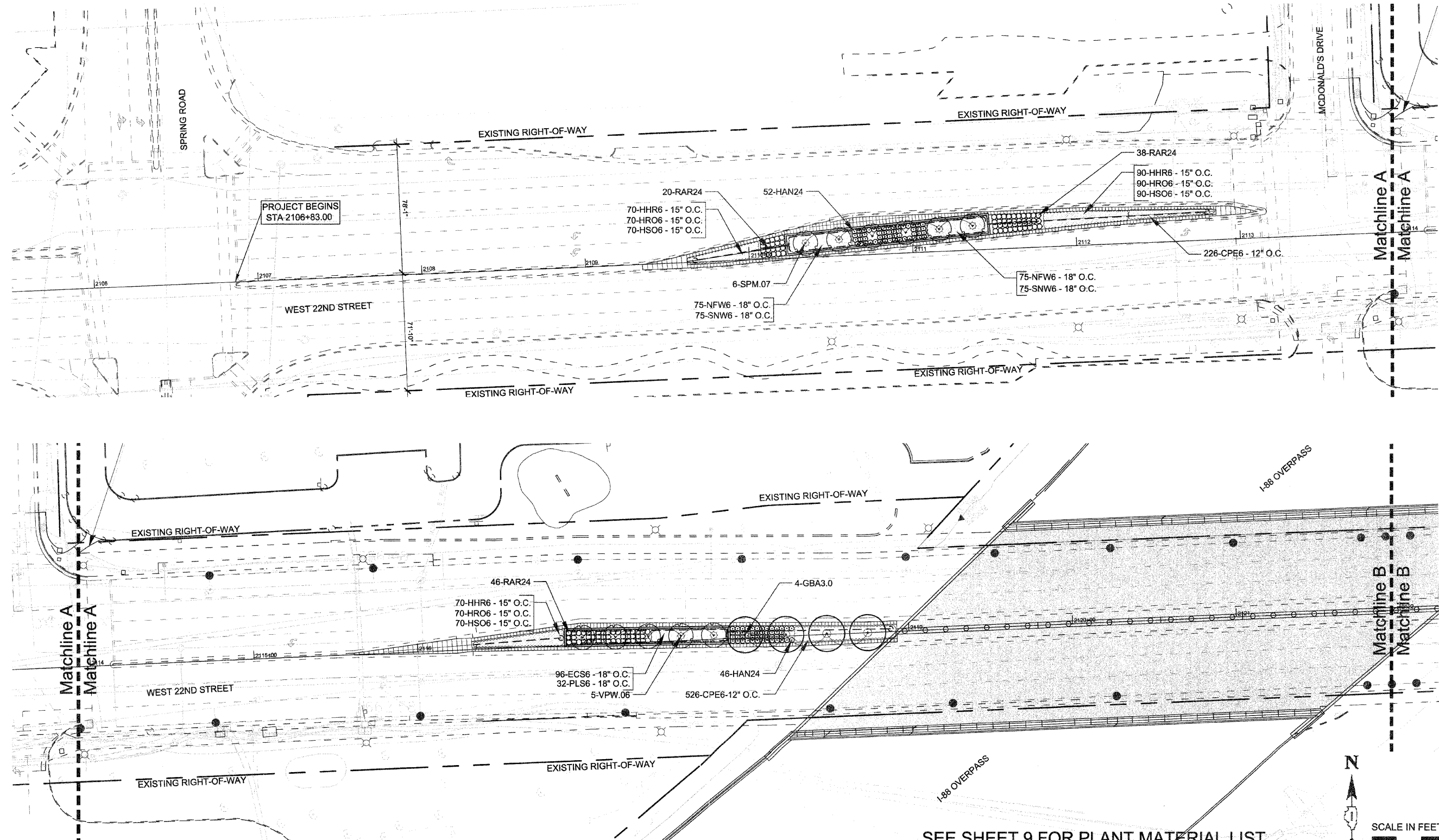

SEE SHEET 9 FOR PLANT MATERIAL LIST

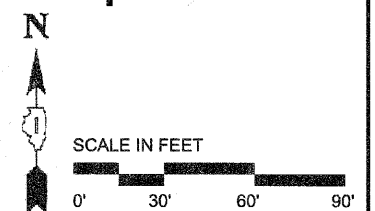

DESIGNED - MEU	REVISED -
DRAWN - BLG	REVISED -
CHECKED - TCK	REVISED -
DATE - 12-19-11	REVISED -

STATE OF ILLINOIS
 DEPARTMENT OF TRANSPORTATION

LANDSCAPE PLAN

SCALE: 1" = 30' PROJECT - 03-0745-008 STA. 2105+83.00 TO STA. 2122+83.00

F.A.U. RTE. 1453	SECTION 11-00043-00-LS	COUNTY DUPAGE	TOTAL SHEETS 20	SHEET NO. 7
CONTRACT 63663		ILLINOIS FED. AID PROJECT TE-00D1 (872)		

J:\PROJECTS\7005\0745-VILLAGE OF OAK BROOK\008-22ND STREET ITEP ENHANCEMENTS\H GRAPHICS\05-DD-CD-07-08-LANDSCAPE.DWG 8
 Plotted: 12/15/2011 4:57 PM By: TKING
 Copyright © 2011, By: Hitchcock Design Group

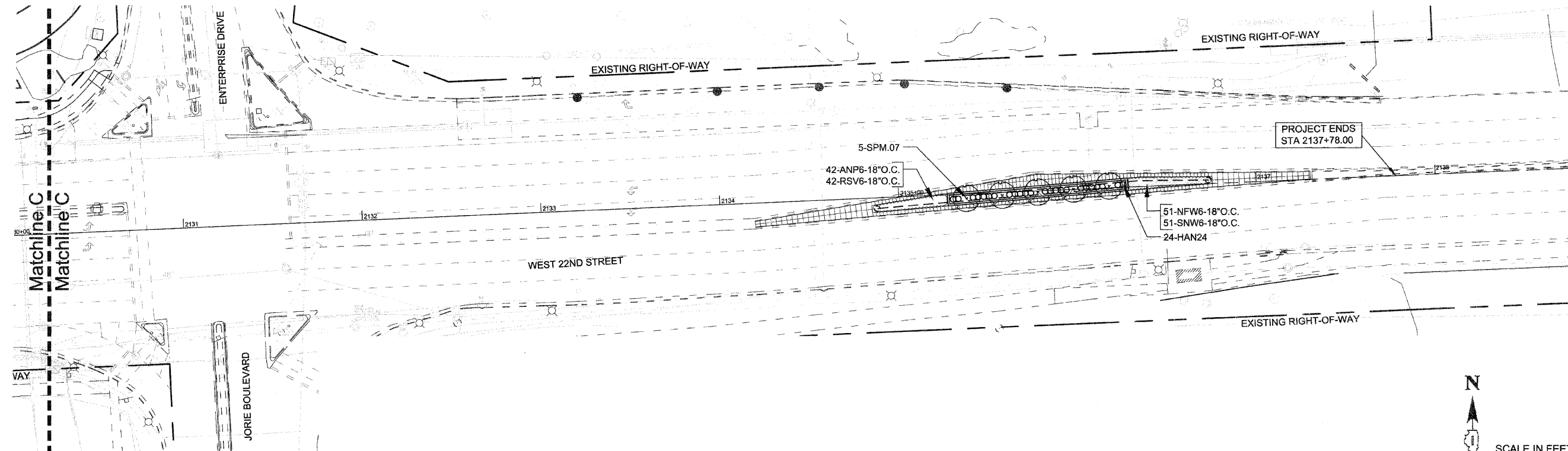
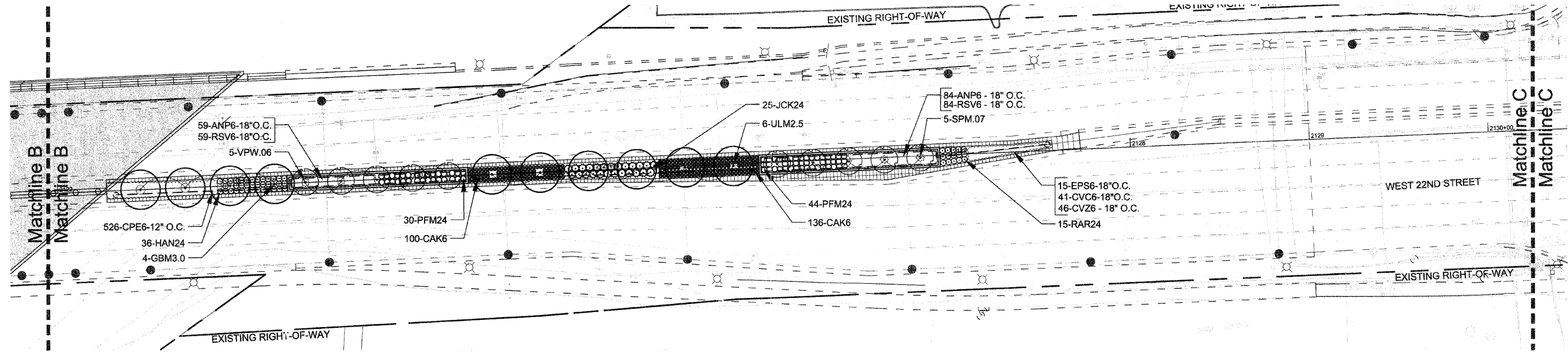

DESIGNED - MEU	REVISED -
DRAWN - BLG	REVISED -
CHECKED - TCK	REVISED -
DATE - 12-19-11	REVISED -

STATE OF ILLINOIS
 DEPARTMENT OF TRANSPORTATION

SEE SHEET 9 FOR PLANT MATERIAL LIST

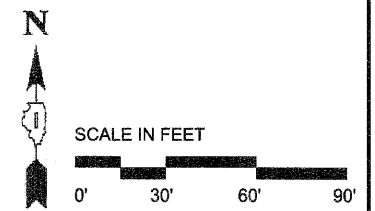

SCALE: 1" = 30'	PROJECT - 03-0745-008 STA. 2122+83.00 TO STA. 2138+83.00
-----------------	--

F.A.U. RTE. 1453	SECTION 11-00043-00-LS	COUNTY DUPAGE	TOTAL SHEETS 20	SHEET NO. 8
CONTRACT 63663				
FED. ROAD DIST. NO. 1 ILLINOIS FED. AID PROJECT TE-001 (872)				

J:\PROJECTS\700\0745-VILLAGE OF OAK BROOK\008-22ND STREET STEP ENHANCEMENTS\1 GRAPHICS\05-DD-CD-09-LANDSCAPE DETAILS AND NOTES.DWG 9
 Plotter: 12/15/2011 4:24 PM By: TKING
 Copyright © 2011, By: Hitchcock Design Group

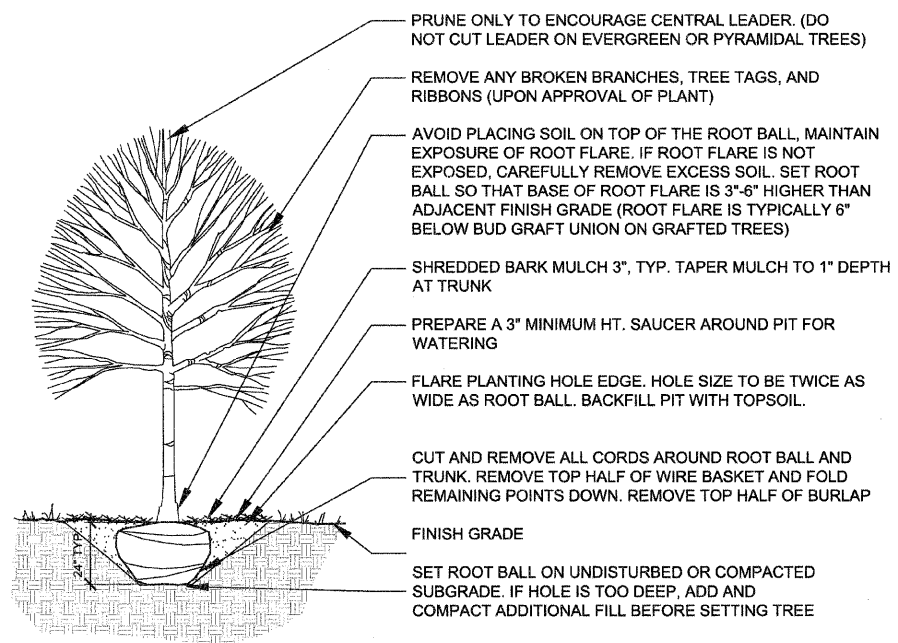

1 DECIDUOUS TREE PLANTING
 SCALE: 1/2" = 1'-0" D-TREE-DEC

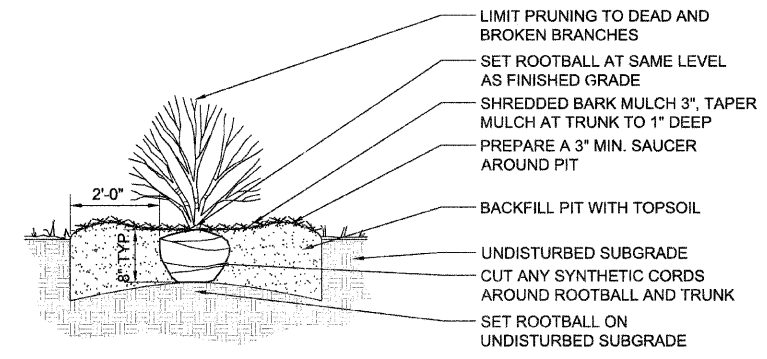

3 SHRUB PLANTING
 SCALE: 1/2" = 1'-0" D-SHRUB

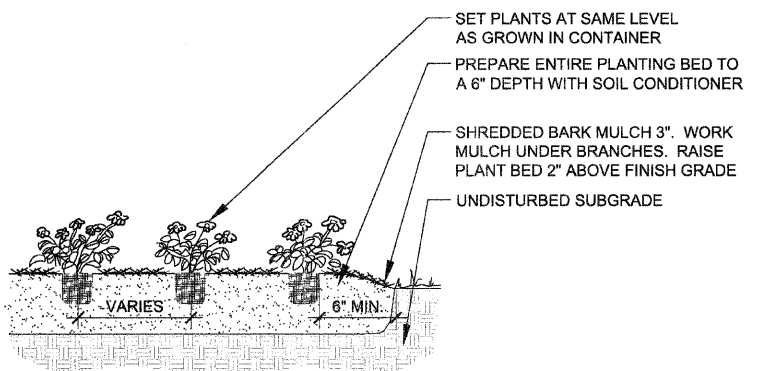

4 PERENNIAL PLANTING
 SCALE: 1/2" = 1'-0" D-ANNUAL-PERENNIAL

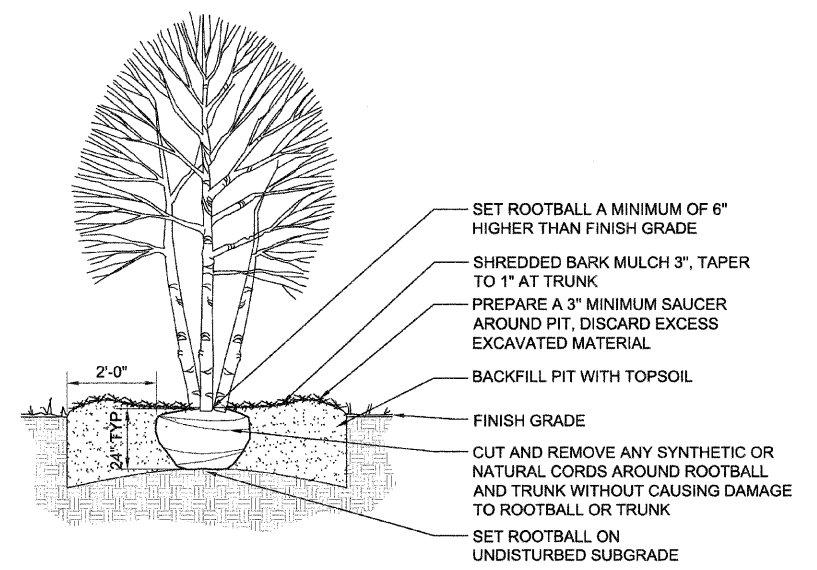

2 ORNAMENTAL TREE PLANTING
 SCALE: 1/2" = 1'-0" D-ORNAMENTAL TREE

PLANT MATERIALS LIST

CODE	BOTANICAL NAME	COMMON NAME	SIZE	QTY
SHADE TREES				
GBA3.0	GINKGO BILOBA 'AUTUMN GOLD'	AUTUMN GOLD GINKGO	3" C	4
GBM3.0	GINKGO BILOBA 'MAGYAR'	MAGYAR UPRIGHT GINKGO	3" C	4
ULM2.5	ULMUS JAPONICA X WILSONIANA 'MORTON'	ACCOLADE™ ELM	2 1/2" C	6
INTERMEDIATE TREES				
SPM.07	SYRINGA PEKINENSIS 'MORTON'	CHINA SNOW PEKING LILAC	7" HT	16
DECIDUOUS SHRUBS				
HAN24	HYDRANGEA ARBOR 'ANNABELLE'	ANNABELLE SMOOTH HYDRANGEA	24" HT	158
PFM24	POTENTILLA FRUTICOSA 'MCKAY'S WHITE'	MCKAY'S WHITE BUSH CINQUEFOIL	24" HT	74
RAR24	ROSA 'AMBER ROSE'	AMBER ROSE FLOWER CARPET ROSE	24" HT	119
VPW.06	VIBURNUM PRUNIFOLIUM 'WILSON'	WILSON BLACKHAW VIBURNUM	6" HT	10
EVERGREEN SHRUBS				
JCK24	JUNIPERUS CHINENSIS 'KALLAY COMPACT'	KALLAY COMPACT CHINESE JUNIPER	24" HT	25
PERENNIALS				
ANP6	ASTER NOVAE ANGLIAE 'PURPLE DOME'	PURPLE DOME NEW ENGLAND ASTER	1 GAL	185
CAK6	CALAMAGROSTIS X ACUTIFLORA 'KARL FOERSTER'	KARL FOERSTER FEATHER REED GRASS	1 GAL	236
CPE6	CAREX PENNSYLVANICA "	OAK SEDGE	1 GAL	1278
CVC6	COREOPSIS VERTICILLATA 'CRÈME BRULÉE'	CRÈME BRULÉE THREADLEAF COREOPSIS	1 GAL	41
CVZ6	COREOPSIS VERTICILLATA 'ZAGREB'	ZAGREB THREADLEAF COREOPSIS	1 GAL	46
EPS6	ECHINACEA PARADOX	YELLOW CONEFLOWER	1 GAL	15
ECS6	ECHINACEA 'HARVEST MOON'	HARVEST MOON CONEFLOWER	1 GAL	96
HHR6	HEMEROCALLIS 'HAPPY RETURNS'	HAPPY RETURNS DAYLILY	1 GAL	230
HRO6	HEMEROCALLIS 'ROSEY RETURNS'	ROSEY RETURNS DAYLILY	1 GAL	230
HSO6	HEMEROCALLIS 'STELLA DE ORO'	STELLA DE ORO DWARF DAYLILY	1 GAL	230
NFW6	NEPETA X FAASSENII 'WALKER'S LOW'	WALKER'S LOW CATMINT	1 GAL	201
PLS6	PEROVSKIA ATRIPLICIFOLIA 'LITTLE SPIRE'	LITTLE SPIRE RUSSIAN SAGE	1 GAL	32
RSV6	RUDBECKIA SPECIOSA 'VIETTE'S LITTLE SUZY'	VIETTE'S LITTLE SUZY BLACK-EYED SUSAN	1 GAL	185
SNW6	SALVIA NEMOROSA 'WESUWE'	WESUWE SALVIA	1 GAL	201
TOTAL PERENNIALS:				3206

ALL PERENNIALS TO BE PAID FOR AS PERENNIAL PLANTS, ORNAMENTAL TYPE, GALLON POT (1 UNIT = 100 PLANTS)

PLANTING NOTES

- SOD TO LIMITS OF DISTURBANCE FOR RESTORATION ONLY. CONTRACTOR IS RESPONSIBLE FOR RESTORATION OF ANY UNAUTHORIZED DISRUPTION OUTSIDE OF DESIGNATED CONSTRUCTION AREA.
- CONTRACTOR IS RESPONSIBLE FOR EROSION CONTROL IN ALL DISTURBED AREAS. ALL DISTURBED AREAS ARE TO BE PROTECTED WITHIN 24 HOURS. DO NOT DISTURB MORE AREA THAN CAN BE COMPLETED AND PROTECTED WITHIN 24 HOURS.
- PLANTS AND OTHER MATERIALS ARE QUANTIFIED AND SUMMARIZED FOR THE CONVENIENCE OF THE DEPARTMENT AND LOCAL AGENCY. CONFIRM AND INSTALL SUFFICIENT QUANTITIES TO COMPLETE THE WORK AS DRAWN AND SPECIFIED.
- REFER TO THE SPECIAL PROVISIONS FOR ADDITIONAL CONDITIONS, STANDARDS AND NOTES.







DESIGNED - MEU	REVISED -
DRAWN - BLG	REVISED -
CHECKED - TCK	REVISED -
DATE - 12-19-11	REVISED -

STATE OF ILLINOIS
 DEPARTMENT OF TRANSPORTATION

LANDSCAPE DETAILS

SCALE: AS SHOWN PROJECT - 03-0745-008

F.A.U. RTE.	SECTION	COUNTY	TOTAL SHEETS	SHEET NO.
1453	11-00043-00-LS	DUPAGE	20	9
CONTRACT 63663				
FED. ROAD DIST. NO. 1 ILLINOIS FED. AID PROJECT TE-5001 (872)				

- LEGEND**
-  EXISTING LIGHT FIXTURE
 -  MODIFY EXISTING STREET LIGHT CIRCUIT
 -  PROPOSED UNIT DUCT, 1" (2#6, #6G XLP-USE)
 -  PROPOSED GALVANIZED STEEL CONDUIT
 -  EXISTING ELECTRICAL CONTROL CABINET

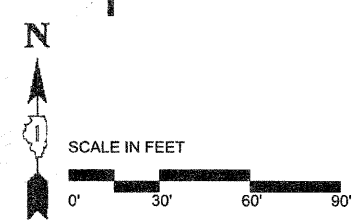
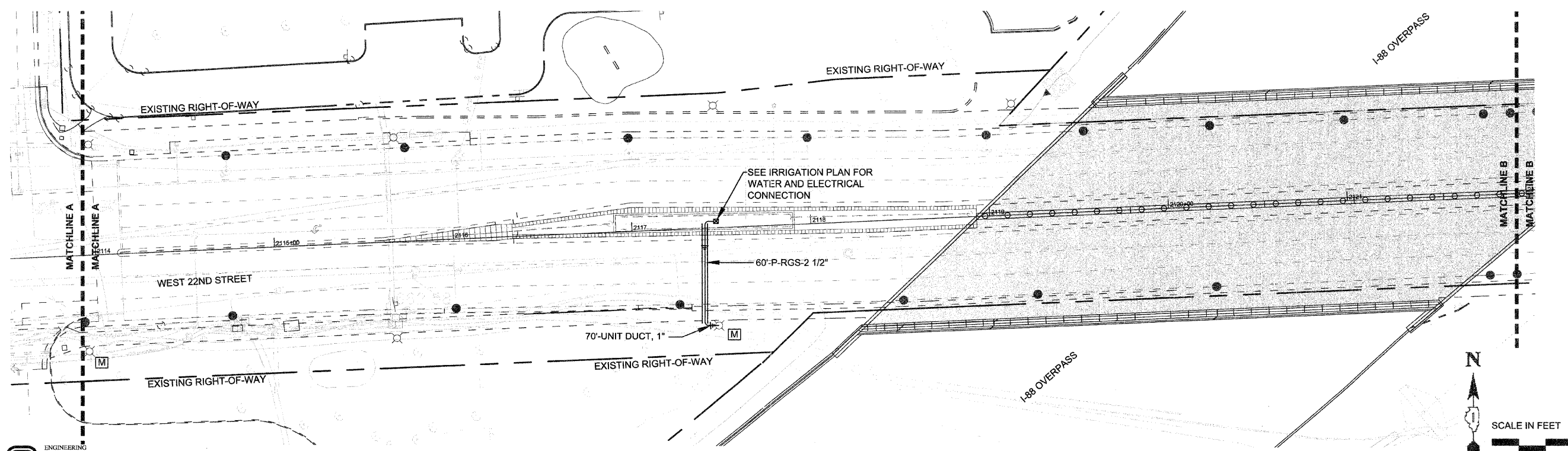
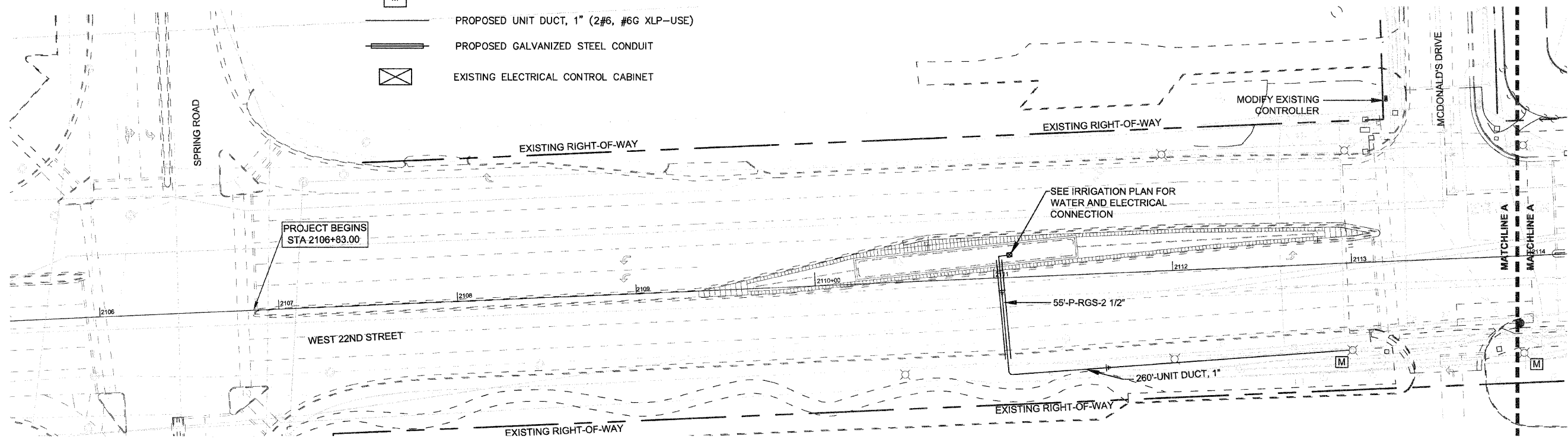

J:\PROJECTS\7005\0745-VILLAGE OF OAK BROOK\008-22ND STREET ITEP ENHANCEMENTS\H GRAPHICS\05-00-CD\10-11-ELECTRICAL.DWG 10
 Plotted: 12/19/2011 11:40 AM By: TKNC
 Copyright © 2011, By: Hitchcock Design Group



DESIGNED - MEU	REVISED -
DRAWN - BLG	REVISED -
CHECKED - TCK	REVISED -
DATE - 12-19-11	REVISED -

**STATE OF ILLINOIS
DEPARTMENT OF TRANSPORTATION**

ELECTRICAL PLAN

SCALE: 1" = 30' PROJECT - 03-0745-008 STA. 2105+83.00 TO STA. 2122+83.00

F.A.U. RTE. 1453	SECTION 11-00043-00-LS	COUNTY DUPAGE	TOTAL SHEETS 20	SHEET NO. 10
CONTRACT 63663				
FED. ROAD DIST. NO. 1 ILLINOIS FED. AID PROJECT TE-001 (872)				

J:\PROJECTS\7005\0745-VILLAGE OF OAK BROOK\008-22ND STREET ITEP ENHANCEMENTS\H GRAPHICS\05-DD-CO\10-11-ELECTRICAL.DWG 11
 Plotfile: 12/19/2011 11:42 AM By: TKING
 Copyright © 2011, By: Hitchcock Design Group

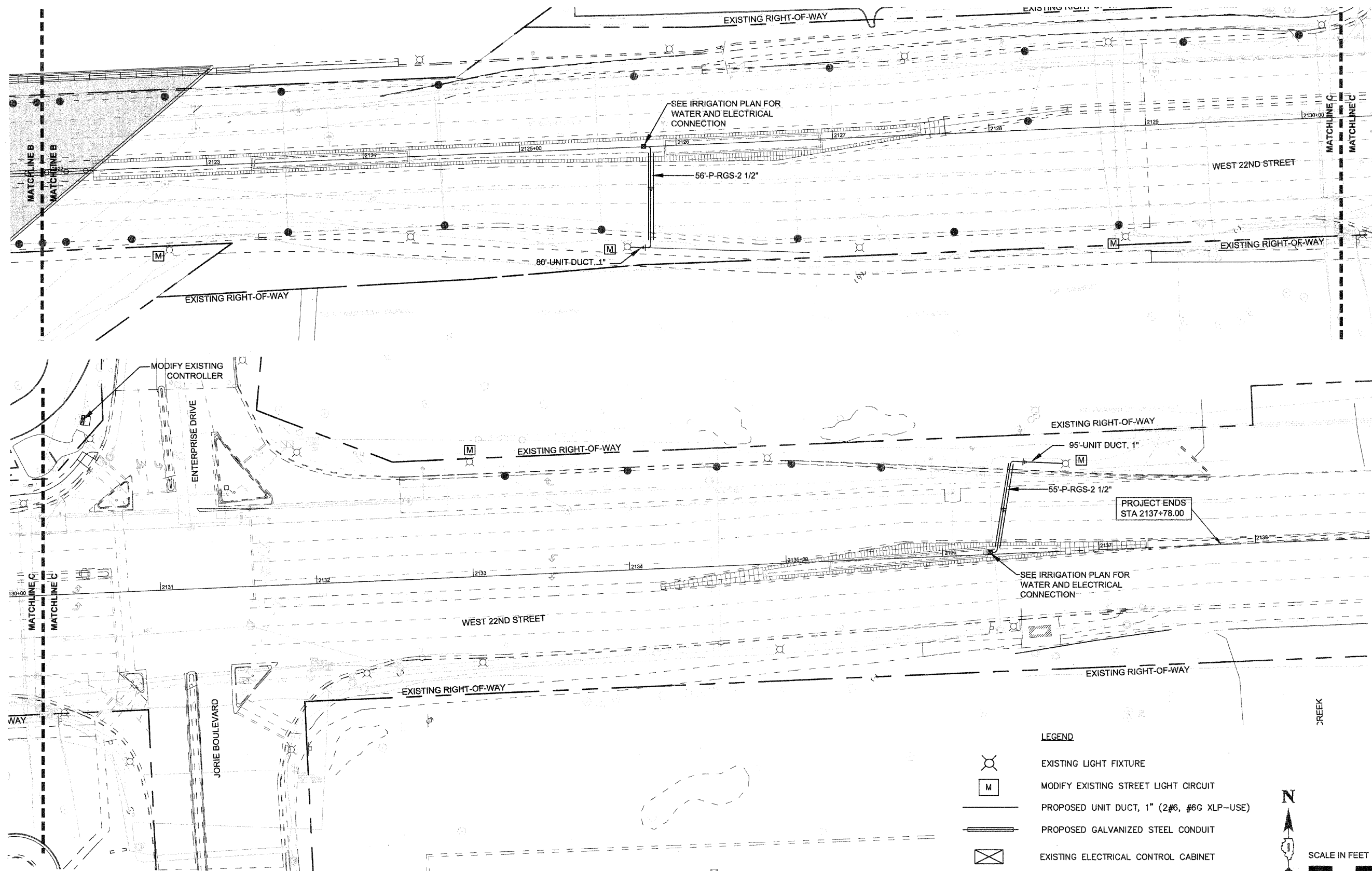

- LEGEND**
- EXISTING LIGHT FIXTURE
 - MODIFY EXISTING STREET LIGHT CIRCUIT
 - PROPOSED UNIT DUCT, 1" (2#6, #6G XLP-USE)
 - PROPOSED GALVANIZED STEEL CONDUIT
 - EXISTING ELECTRICAL CONTROL CABINET

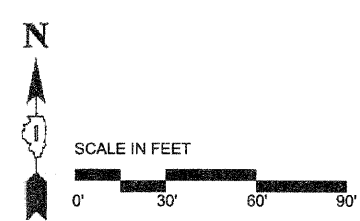

DESIGNED - MEU	REVISED -
DRAWN - BLG	REVISED -
CHECKED - TCK	REVISED -
DATE - 12-19-11	REVISED -

STATE OF ILLINOIS
DEPARTMENT OF TRANSPORTATION

ELECTRICAL PLAN

SCALE: 1" = 30' PROJECT - 03-0745-008 STA. 2122+83.00 TO STA. 2138+83.00

F.A.U. RTE. 1453	SECTION 11-00043-00-LS	COUNTY DUPAGE	TOTAL SHEETS 20	SHEET NO. 11
CONTRACT 63663				
FED. ROAD DIST. NO. 1 ILLINOIS FED. AID PROJECT TE-001 (672)				

J:\PROJECTS\7005\0745-VILLAGE OF OAK BROOK\008-22ND STREET ITEP ENHANCEMENTS\H GRAPHICS\05-DD-CO\12-ELECTRICAL DETAILS AND NOTES.DWG 12
 Plotfile: 12/19/2011 5:03 PM By: TKING
 Copyright © 2011, By: Hitchcock Design Group

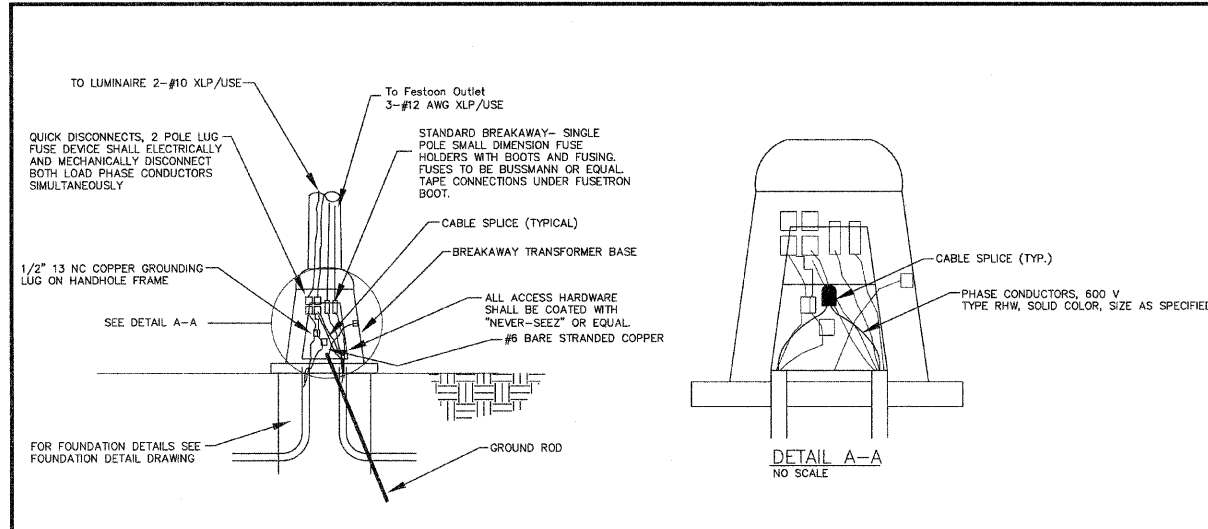

EXISTING POLE BASE DETAIL
NO SCALE

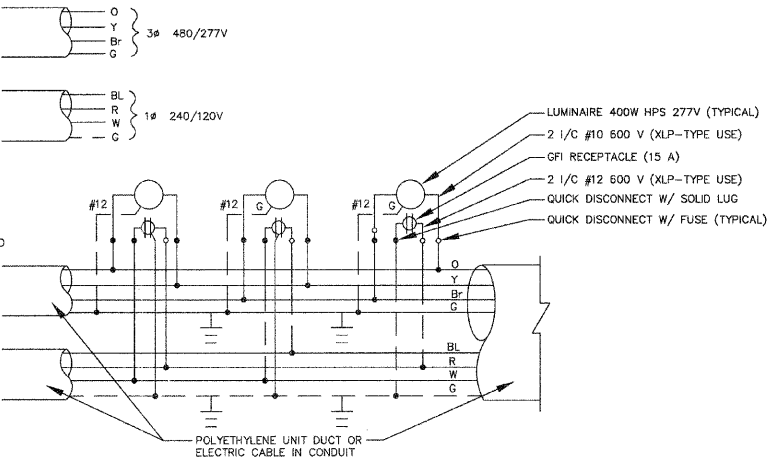

EXISTING LIGHT POLE WIRING W/FESTOON
 240/120 VOLT 1 PHASE 6 WIRE
 480/277 VOLT 3 PHASE LIGHTING
 240/120 VOLT 1 PHASE FESTOON

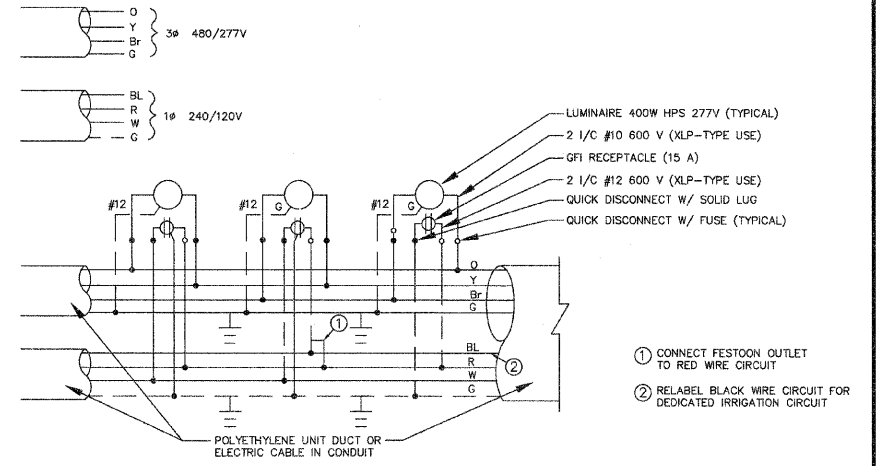

EXISTING LIGHT POLE WIRING W/FESTOON (MODIFIED)
 240/120 VOLT 1 PHASE 6 WIRE
 480/277 VOLT 3 PHASE LIGHTING
 240/120 VOLT 1 PHASE FESTOON

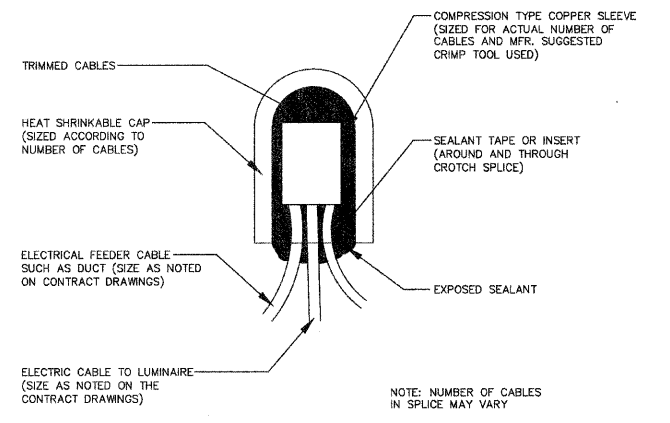

ABOVE GROUND SPlicing ELECTRIC CABLE
NO SCALE

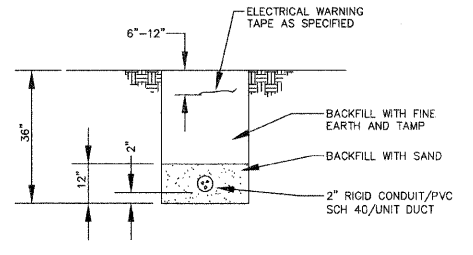

TRENCH BACKFILL FOR STREETLIGHTING DETAIL
NO SCALE

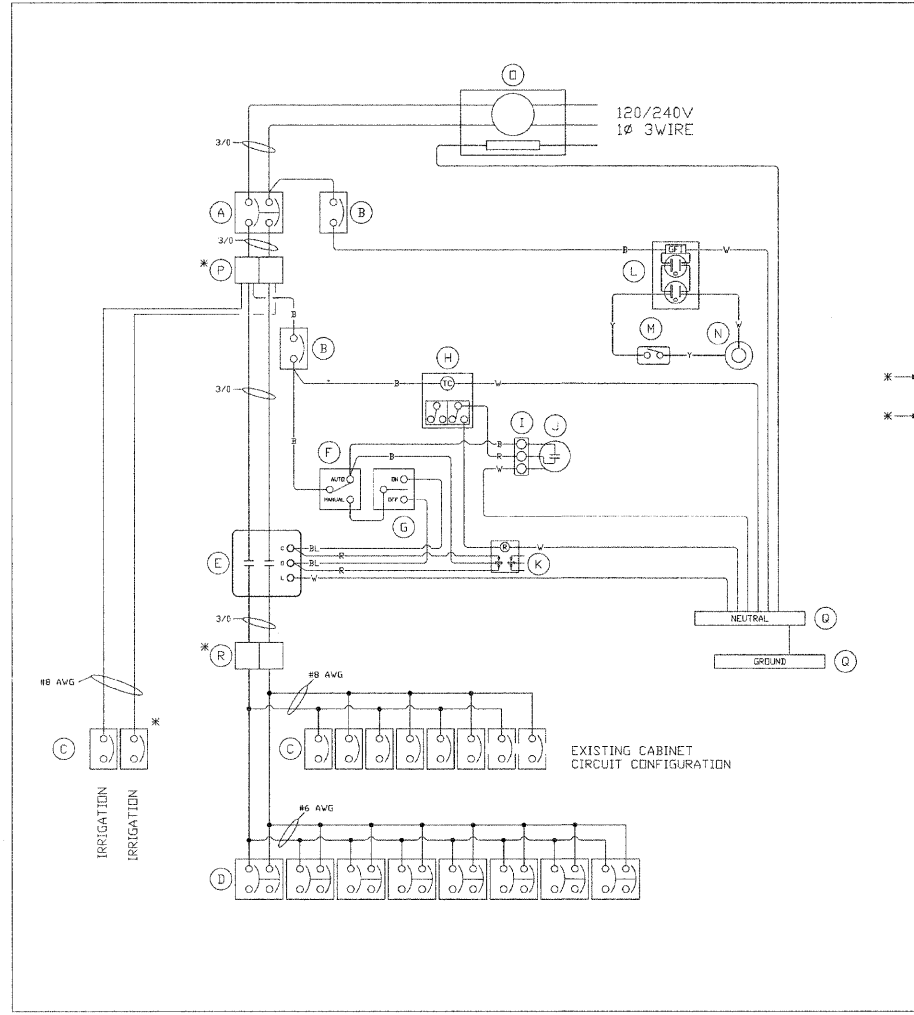

BILL OF MATERIALS		
ITEM	QTY	DESCRIPTION
A	1	C/H ED2200L 2P 200A MAIN BREAKER
B	2	C/H GHC1015 1P 15A CTRL/AUX BREAKER
C	8	C/H GHC1030 1P 30A FESTOON BREAKERS
D	8	C/H GHC2050 2P 50A BRANCH BREAKERS
E	1	SQ.D. 8903PBV10V02 120V COIL CONTACTOR
F	1	LEVITON CSB3-20 3-WAY TOGGLE SWITCH
G	1	LEVITON 1257 MOMENTARY SWITCH
H	1	TORK DZS200BP 2 CH TIME CLOCK
I	1	CINCH 3PT TERMINAL BLOCK
J	1	FISHER PIERCE FPA105M PHOTOCELL
K	1	MAGNECRAFT W389ACX-9 120V COIL RELAY
L	1	HUBBELL GF201L 20A GFCI RECP.
M	1	MICRO BA-2RQ1-A2 DDDR SWITCH
N	1	RAB VX100DG LIGHT FIXTURE
O	1	MILBANK UB949-RL-TG-KK METER FITTING
P	2	FERRAZ 69132 SPLICE BLOCK
Q	2	12 x 1 x 1/4 GROUND/NEUTRAL BUS
R	2	FERRAZ 67622 SPLICE BLOCK

NOTES:
 1. ALL POWER WIRING WILL BE RHH/RHW
 2. ALL CONTROL WIRING WILL BE #12 MTW
 3. WIRE COLORS:
 BL = BLUE
 W = WHITE
 B = BLACK
 R = RED
 Y = YELLOW

* - CABINET MODIFICATION

SCALE: NTS	APPROVED BY:	DRAWN BY: JLM
DATE: 11/20/11		REVISED:
VILLAGE OF OAK BROOK		
22ND STREET - 1S1HA 1-06-551B		
FESTOON LIGHTING CONTROLLER		DRAWING NUMBER: 11201101JB

EXISTING FESTOON CABINET SCHEMATIC



DESIGNED - MEU	REVISED -
DRAWN - BLG	REVISED -
CHECKED - TCK	REVISED -
DATE - 12-19-11	REVISED -

STATE OF ILLINOIS
DEPARTMENT OF TRANSPORTATION

ELECTRICAL DETAILS AND NOTES

SCALE: AS SHOWN PROJECT - 03-0745-008

F.A.U. RTE. 1453	SECTION 11-00043-00-LS	COUNTY DUPAGE	TOTAL SHEETS 20	SHEET NO. 12
CONTRACT 63663				
FED. ROAD DIST. NO. 1 ILLINOIS FED. AID PROJECT TE-001 (872)				

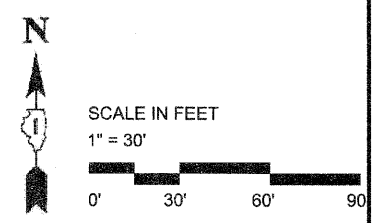
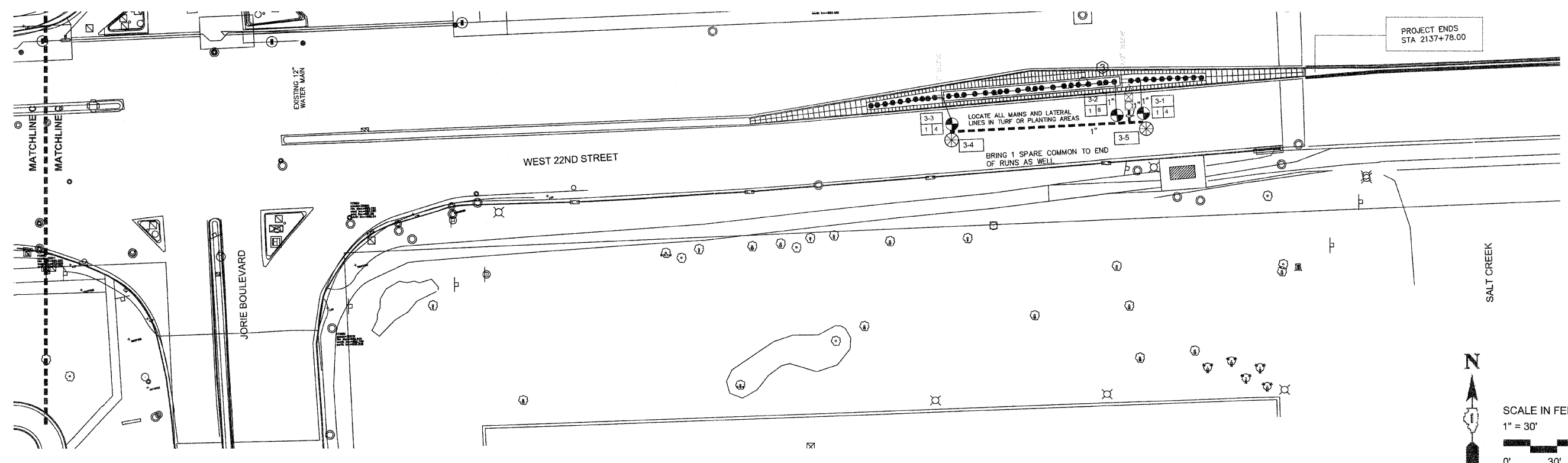
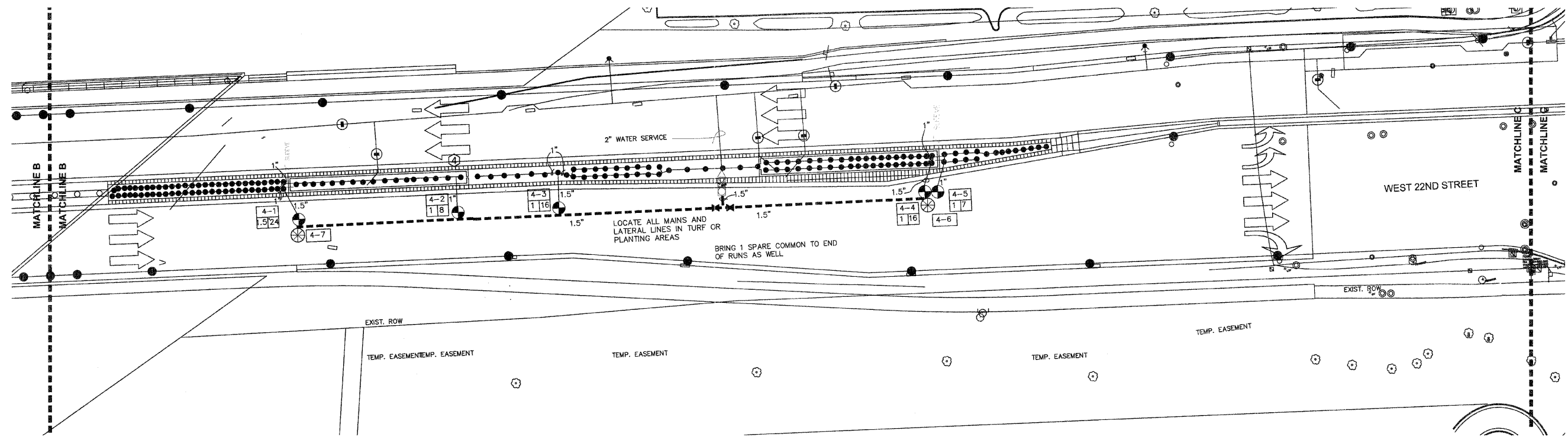

G:\HITCHCOCK\22NDST\11_OAK_BROOK_TIEP - STANDARD\04-IRRIGATION\2.19.11.DWG IR2
 Plotted: 12/19/2011 10:46 AM by: ###
 Copyright © 2011, By Hitchcock Design Group



DESIGNED - DPF
 DRAWN - DPF
 CHECKED - TCK
 DATE - 12-19-11

REVISED -
 REVISED -
 REVISED -
 REVISED -

STATE OF ILLINOIS
DEPARTMENT OF TRANSPORTATION

IRRIGATION PLANS

SCALE: 1" = 30' PROJECT NO: 03-0745-008 STA. 2106+83.00 TO STA. 2106+83.00

F.A.U. RTE.	SECTION	COUNTY	TOTAL SHEETS	SHEET NO.
1453	11-00043-000-LS	DUPAGE	20	14
63663				
FED. ROAD DIST. NO. 1 ILLINOIS FED. AID PROJECT TE-001 (872)				

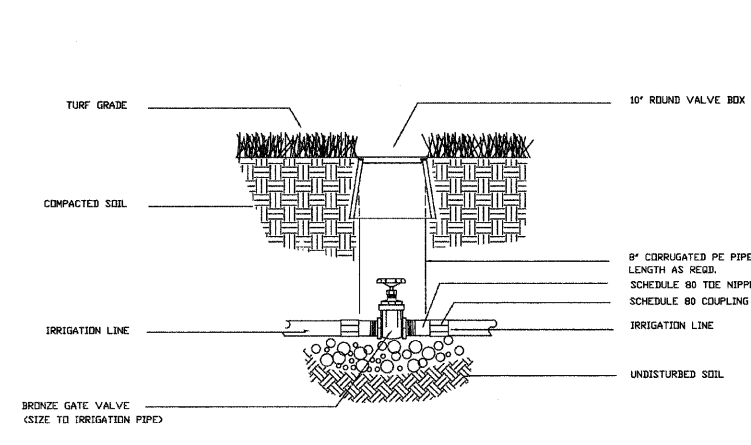

1 ISOLATION VALVE 3" AND SMALLER NO SCALE

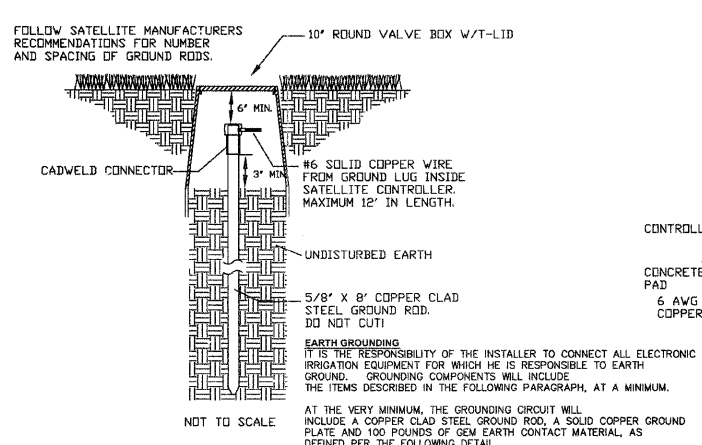

2 CONTROLLER GROUNDING NO SCALE

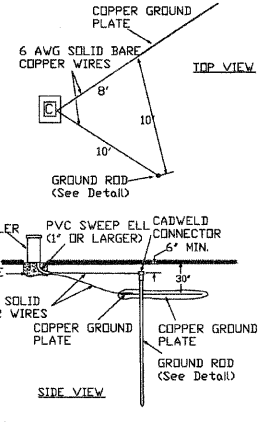

3 SPRAY HEAD AND SMALL ROTOR HEAD NO SCALE

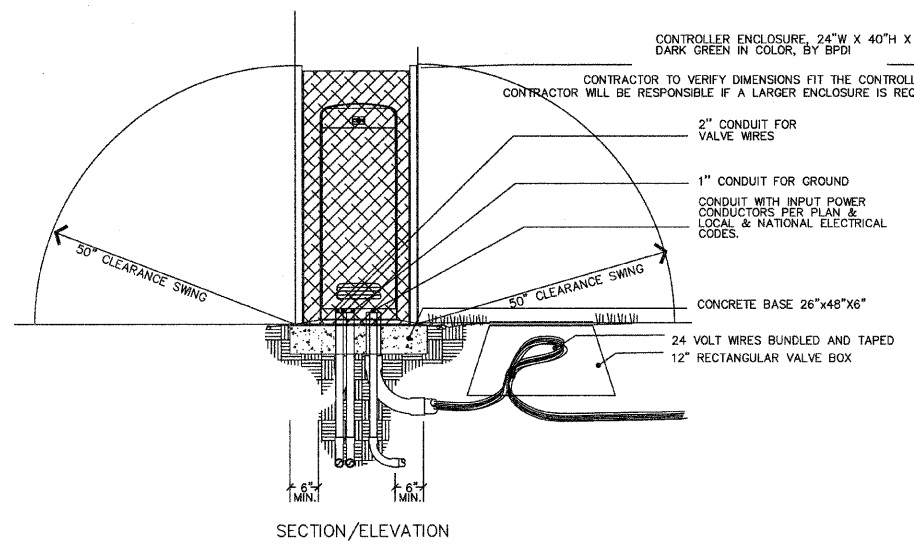
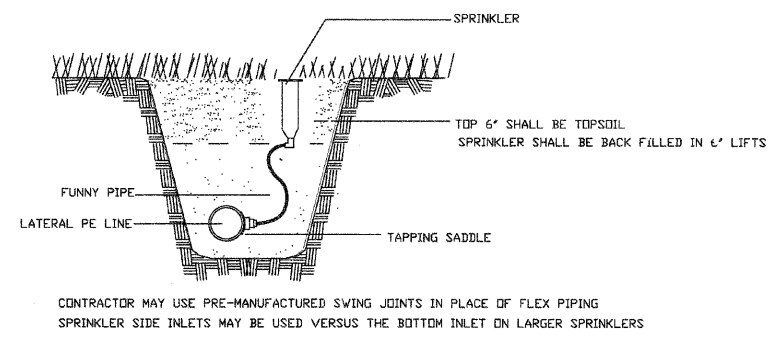

4 CONTROLLER MOUNT NO SCALE

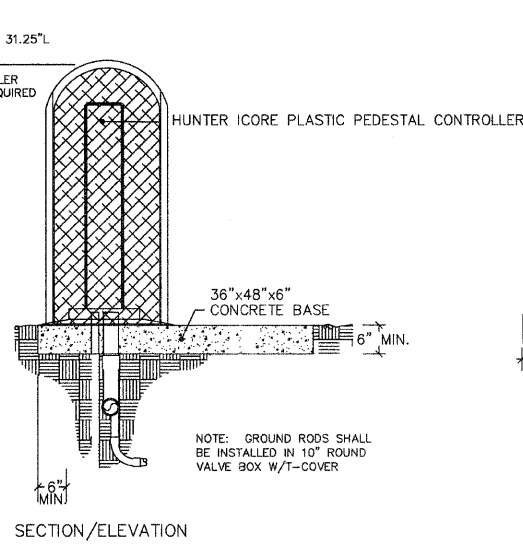

5 BACKFLOW / METER ENCLOSURE NO SCALE

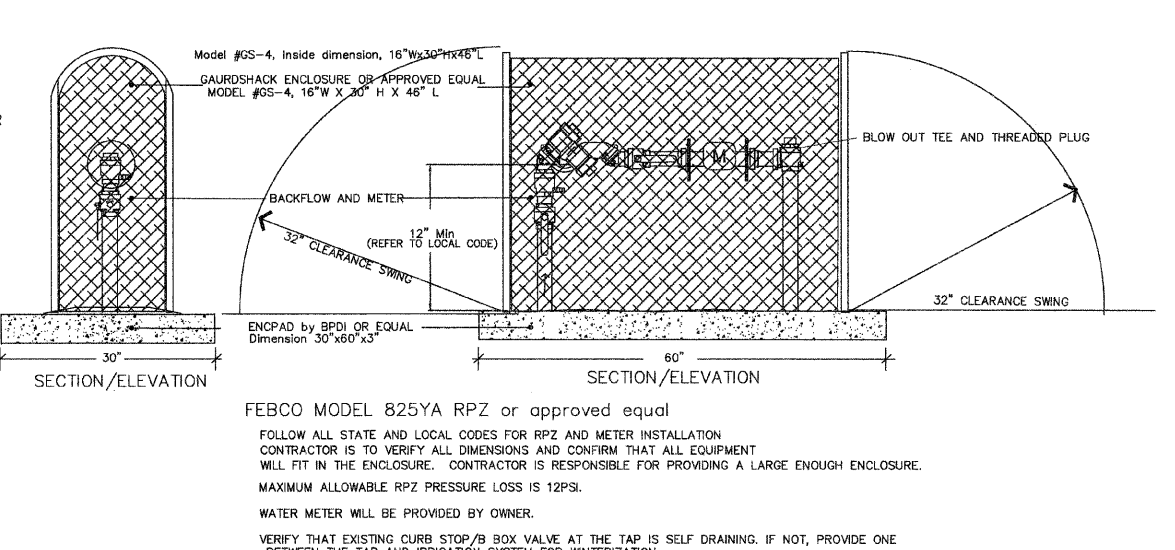

5 BACKFLOW / METER ENCLOSURE NO SCALE

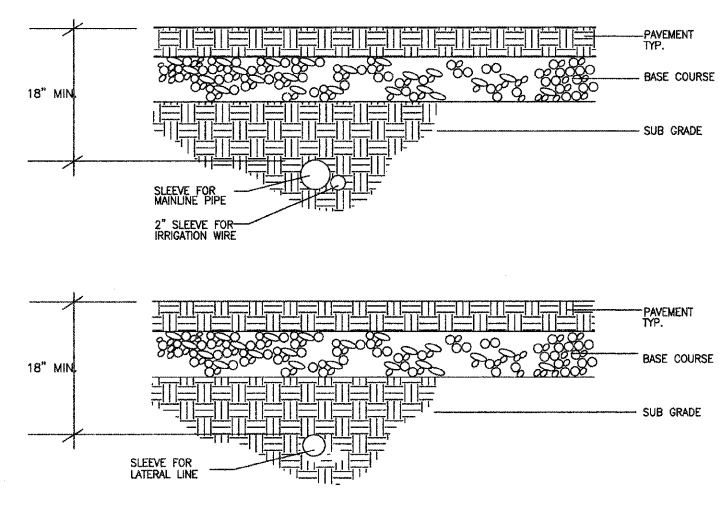

6 SLEEVING NO SCALE

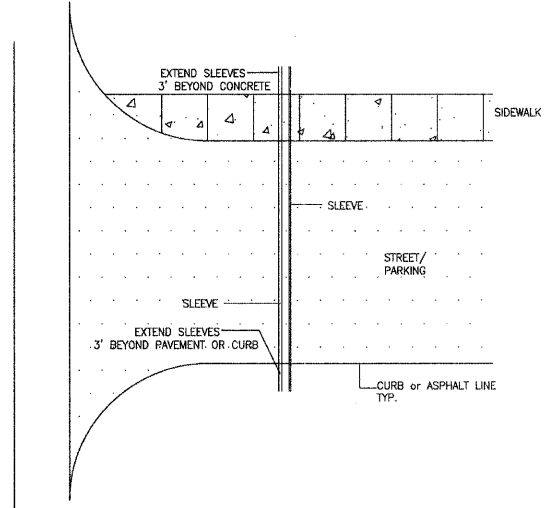

7 ELECTRIC VALVE / MULTIPLE VALVES - PE PIPES NO SCALE

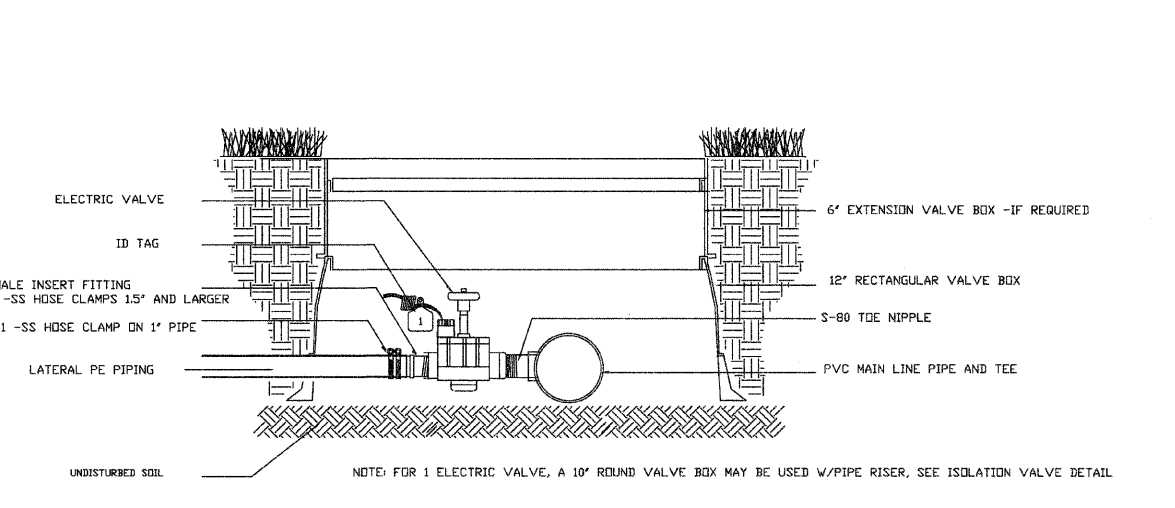

7 ELECTRIC VALVE / MULTIPLE VALVES - PE PIPES NO SCALE

25-HITCHCOCK\22ND2011\04K BRCK IREP - STANDARD\04-IRRIGATION\12-19-11\DWG_IR4
 Plotted: 12/19/2011 10:47 AM By: HHH
 Created: 12/19/2011 By: Hitchcock Design Group



DESIGNED - DPF	REVISED -
DRAWN - DPF	REVISED -
CHECKED - TCK	REVISED -
DATE - 12-19-11	REVISED -

STATE OF ILLINOIS
DEPARTMENT OF TRANSPORTATION

IRRIGATION DETAILS

SCALE: AS SHOWN PROJECT NO: 03-0745-008 STA. 2106+83.00 TO STA. 2106+83.00

F.A.U. RTE. 1453	SECTION 11-00043-000-LS	COUNTY DUPAGE	TOTAL SHEETS 20	SHEET NO. 16
63663			FED. ROAD DIST. NO. 1 ILLINOIS FED. AID PROJECT TE-001 (872)	

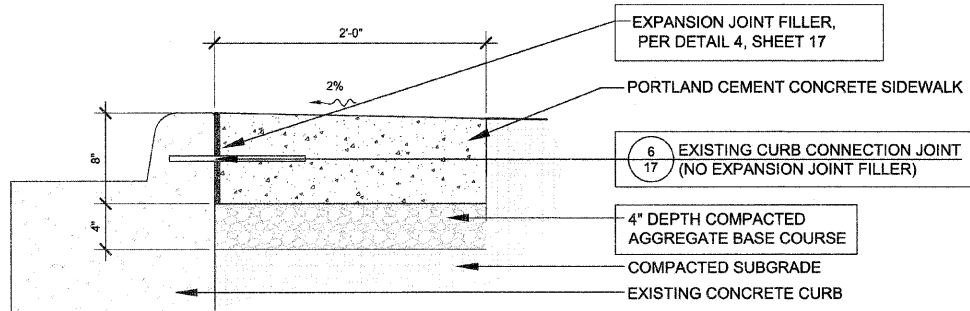

1 P.C.C. SIDEWALK 8 INCH, SPECIAL
SCALE: 1 1/2" = 1'-0"
D-CONC-STRIP

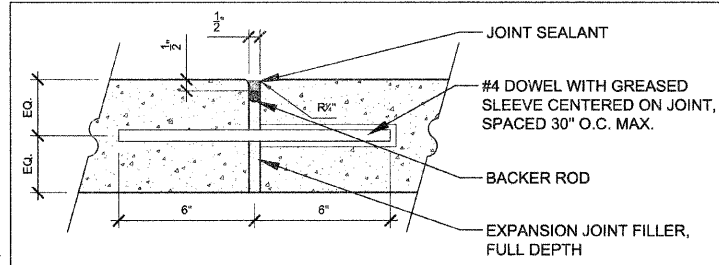

4 EXPANSION JOINT
SCALE: 3" = 1'-0"
D-JOINT-EXP

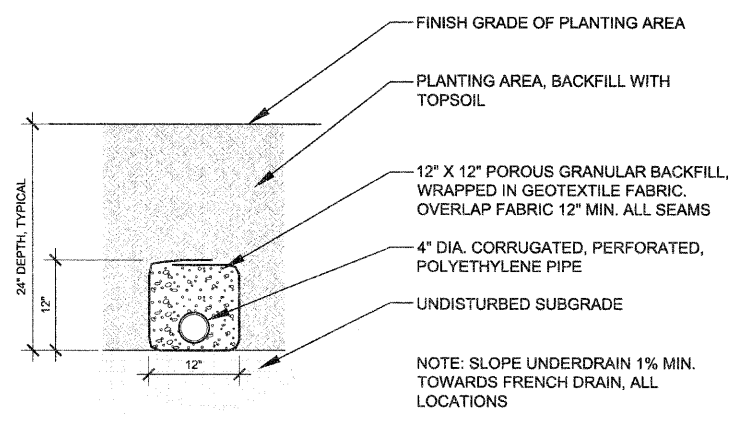

7 UNDERDRAIN
SCALE: 1" = 1'-0"
D-UNDERDRAIN

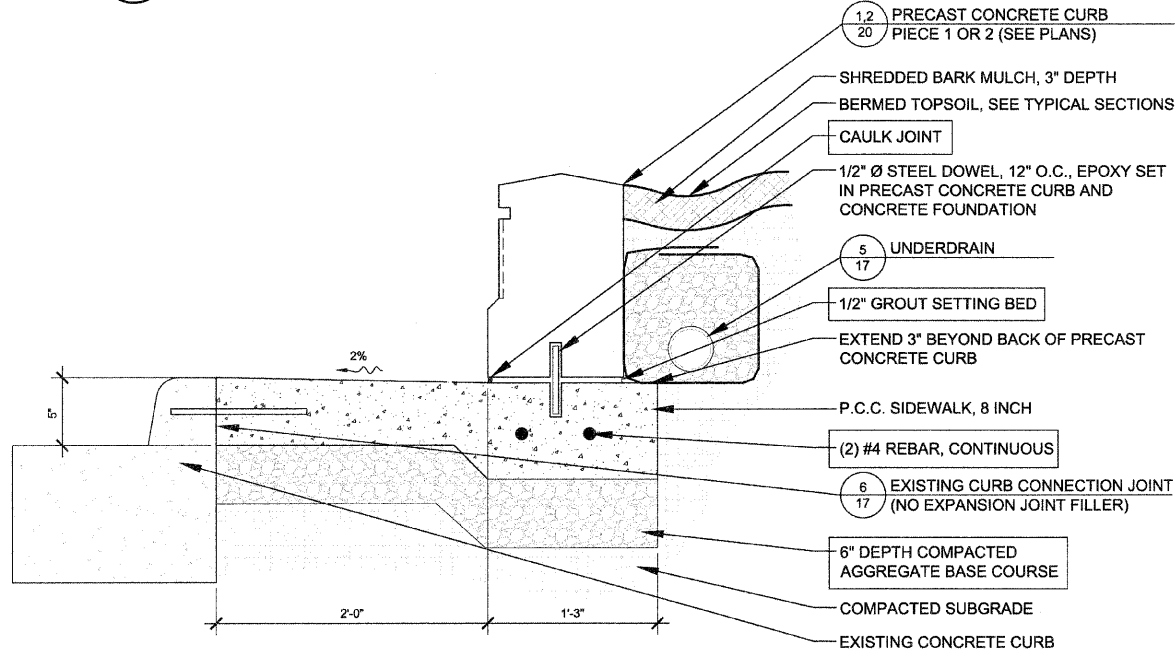

2 P.C.C. SIDEWALK 5 INCH, SPECIAL AT PRECAST CONCRETE CURB
SCALE: 1 1/2" = 1'-0"
D-CONC-STRIP-FOOTING

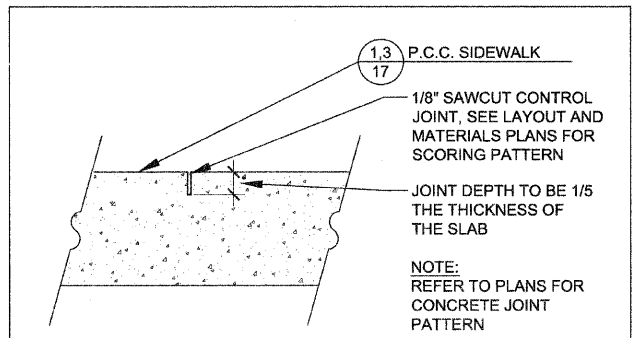

5 CONTROL JOINT
SCALE 3" = 1'-0"
D-JOINT-CONTROL

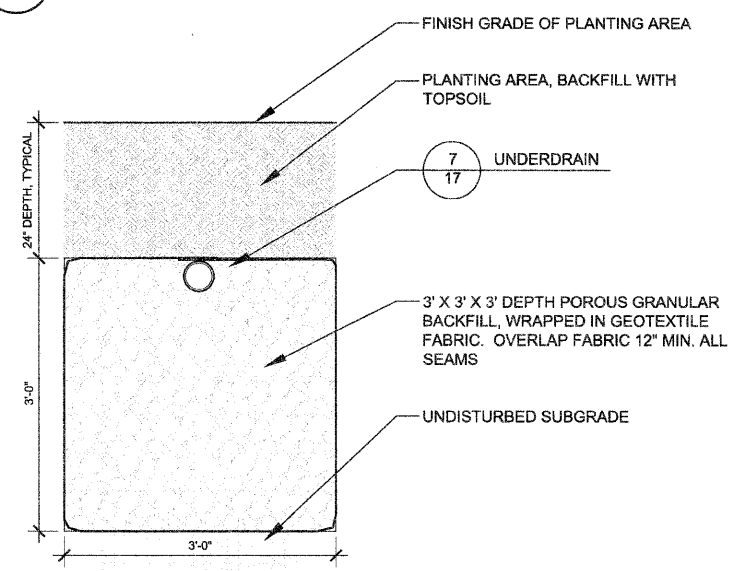

8 FRENCH DRAIN
SCALE: 1" = 1'-0"
D-FRENCH DRAIN

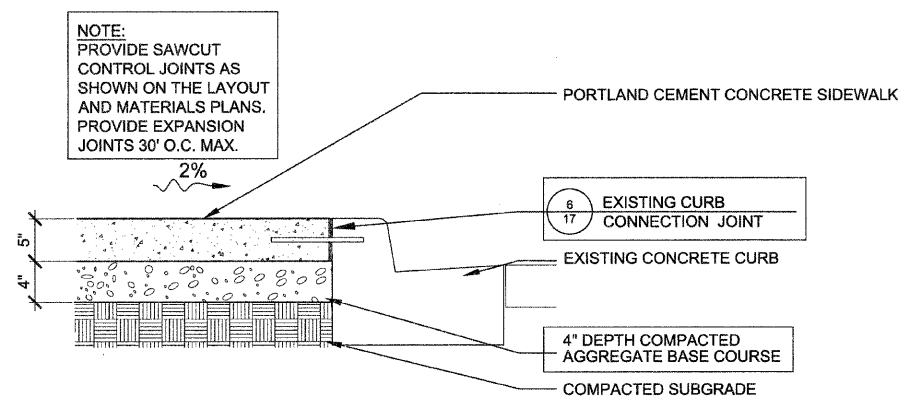

3 P.C.C. SIDEWALK 5 INCH, SPECIAL
NOT TO SCALE
D-CONC-PAV

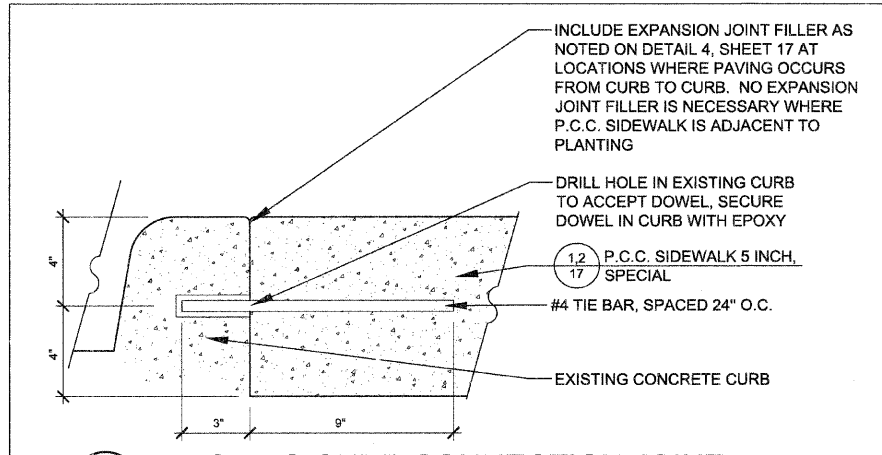

6 EXISTING CURB CONNECTION JOINT
SCALE: 3" = 1'-0"
D-JOINT-EXP-EX CURB

J:\PROJECTS\7005\0745-VILLAGE OF OAK BROOK\008-22ND STREET ITEP ENHANCEMENTS\H GRAPHICS\05-DD-CD\17-20-CONSTRUCTION DETAILS.DWG 17
 P1: 12/16/2011 12:42 PM By: TKING
 Copyright © 2011, By: Hitchcock Design Group



DESIGNED - MEU	REVISED -
DRAWN - BLG	REVISED -
CHECKED - TCK	REVISED -
DATE - 12-19-11	REVISED -

STATE OF ILLINOIS
DEPARTMENT OF TRANSPORTATION

CONSTRUCTION DETAILS

SCALE AS SHOWN PROJECT - 03-0745-008

F.A.U. RTE. 1453	SECTION 11-00043-00-LS	COUNTY DUPAGE	TOTAL SHEETS 20	SHEET NO. 17
CONTRACT 83663				
FED. ROAD DIST. NO. 1 ILLINOIS FED. AID PROJECT TE-001 (872)				

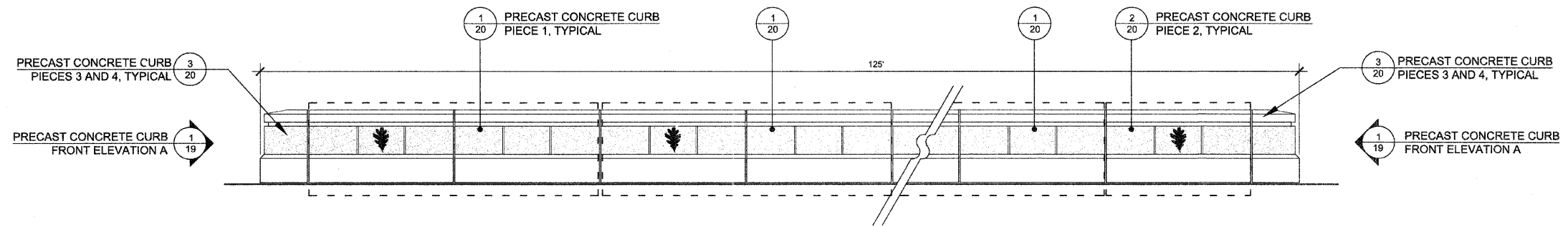

1 PRECAST CONCRETE CURB - SIDE ELEVATION A
SCALE: 3/4" = 1'-0"

LOCATION:
STA. 2110+22.46 TO STA. 2111+47.46

D-ELEV-WALL-SIDE A

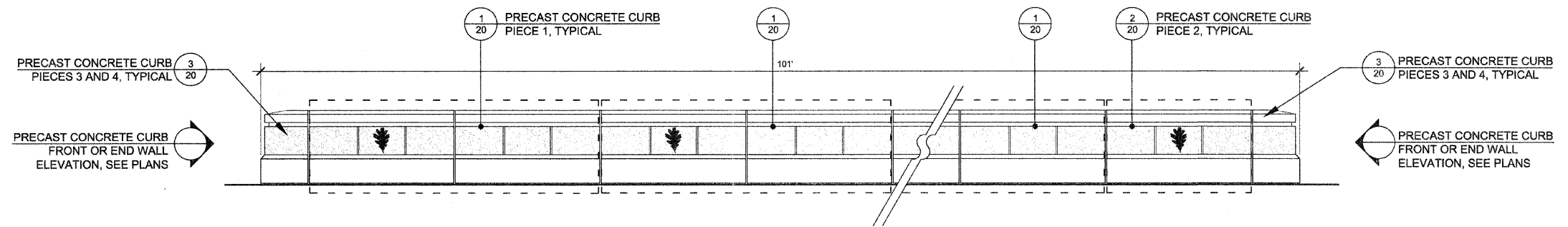

2 PRECAST CONCRETE CURB - SIDE ELEVATION B
SCALE: 3/4" = 1'-0"

LOCATIONS:
STA. 2116+89.93 TO STA. 2117+90.93
STA. 2123+28.37 TO STA. 2124+29.37
STA. 2125+92.27 TO STA. 2126+93.27
STA. 2135+27.20 TO STA. 2136+28.20

D-ELEV-WALL-SIDE B

J:\PROJECTS\7005\0745-VILLAGE OF OAK BROOK\008-22ND STREET TIEP ENHANCEMENTS\H GRAPHICS\05-DD-CD\17-20-CONSTRUCTION DETAIL.S.DWG 18
 Plotted: 12/15/2011 5:09 PM By: TIKING
 Copyright © 2011, By: Hitchcock Design Group



DESIGNED - MEU	REVISED -
DRAWN - BLG	REVISED -
CHECKED - TCK	REVISED -
DATE - 12-19-11	REVISED -

STATE OF ILLINOIS
DEPARTMENT OF TRANSPORTATION

CONSTRUCTION DETAILS

SCALE: AS SHOWN PROJECT - 03-0745-008

F.A.U. RTE.	SECTION	COUNTY	TOTAL SHEETS	SHEET NO.
1453	11-00043-00-LS	DUPAGE	20	18
CONTRACT 63663				
FED. ROAD DIST. NO. 1 ILLINOIS FED. AID PROJECT TE-001 (872)				

J:\PROJECTS\7005\0745-VILLAGE OF OAK BROOK\008-22ND STREET ITP ENHANCEMENTS\H GRAPHICS\05-DD-CD\17-20-CONSTRUCTION DETAILS.DWG 19
 PLOT: 12/19/2011 5:10 PM BY: TKING
 Copyright © 2011, By: Hitchcock Design Group

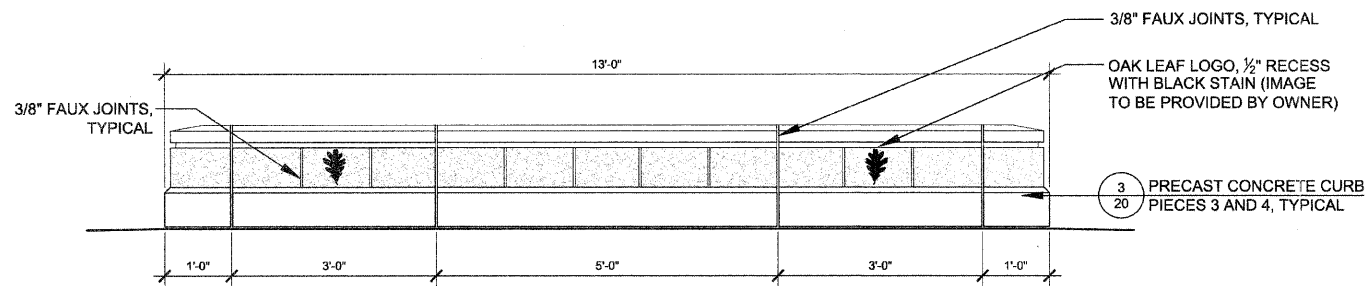

1 PRECAST CONCRETE CURB - FRONT ELEVATION A
 SCALE: 3/4" = 1'-0"
 D-ELEV-WALL-NOSE A

LOCATIONS:
 STA. 2110+22.46
 STA. 2111+47.46

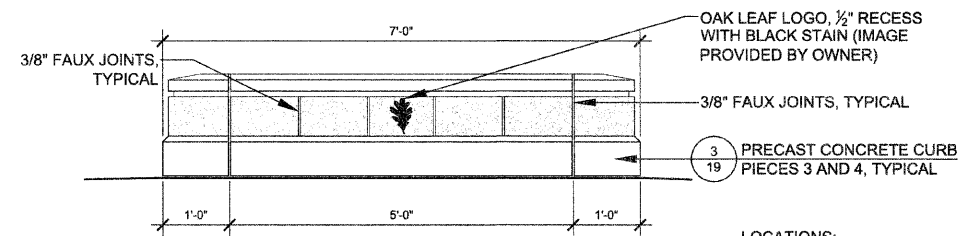

4 PRECAST CONCRETE CURB - FRONT ELEVATION D
 SCALE: 3/4" = 1'-0"
 D-ELEV-WALL-NOSE D

LOCATIONS:
 STA. 2135+27.20
 STA. 2136+28.20

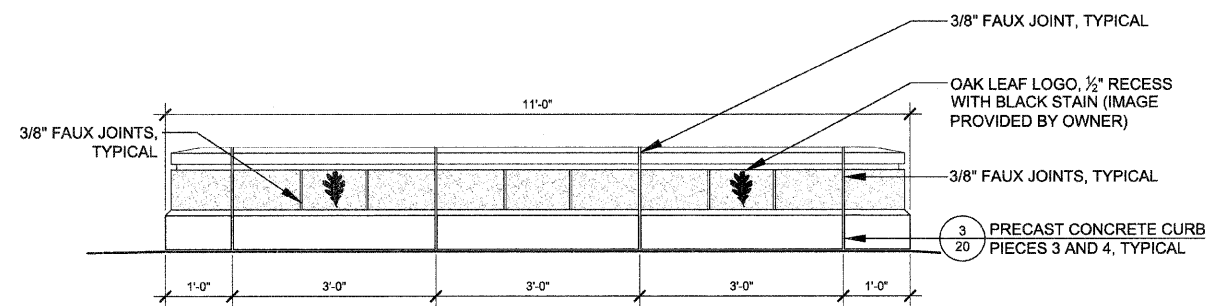

2 PRECAST CONCRETE CURB - FRONT ELEVATION B
 SCALE: 3/4" = 1'-0"
 D-ELEV-WALL-NOSE B

LOCATIONS:
 STA. 2116+89.93
 STA. 2117+90.93
 STA. 2126+93.27

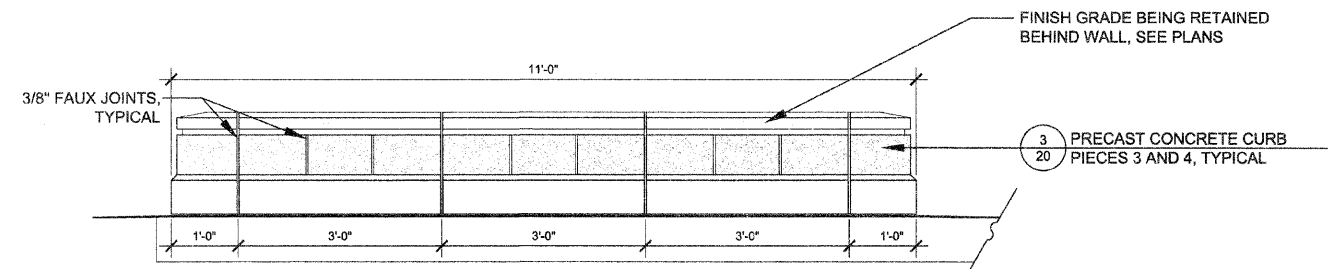

5 PRECAST CONCRETE CURB - END ELEVATION A
 SCALE: 3/4" = 1'-0"
 D-ELEV-WALL-END A

LOCATION:
 STA. 2125+92.27

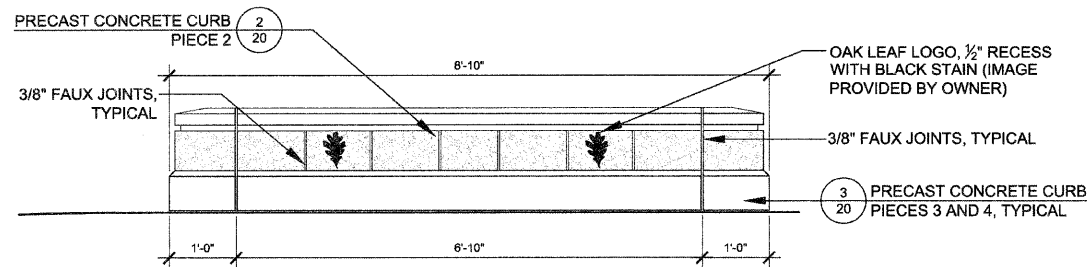

3 PRECAST CONCRETE CURB - FRONT ELEVATION C
 SCALE: 3/4" = 1'-0"
 D-ELEV-WALL-NOSE C

LOCATION:
 STA. 2123+28.37

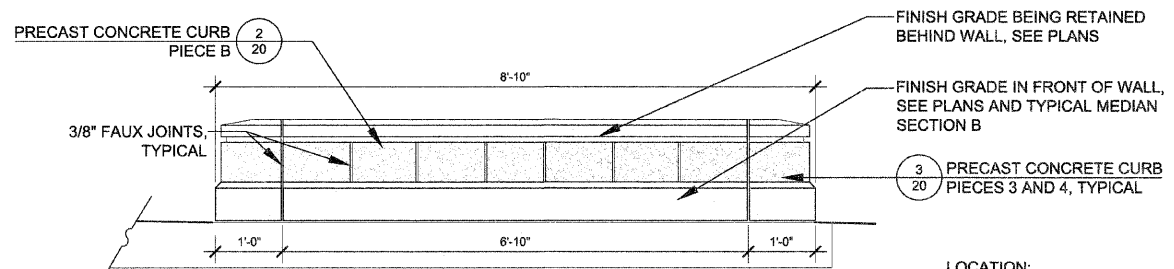

6 PRECAST CONCRETE CURB - END ELEVATION B
 SCALE: 3/4" = 1'-0"
 D-END-ELEV-WALL-B

LOCATION:
 STA. 2124+29.37



DESIGNED - MEU	REVISED -
DRAWN - BLG	REVISED -
CHECKED - TCK	REVISED -
DATE - 12-19-11	REVISED -

STATE OF ILLINOIS
 DEPARTMENT OF TRANSPORTATION

CONSTRUCTION DETAILS

SCALE: AS SHOWN PROJECT - 03-0745-008

F.A.U. RTE.	SECTION	COUNTY	TOTAL SHEETS	SHEET NO.
1453	11-00043-00-LS	DUPAGE	20	19
CONTRACT 63663				
FED. ROAD DIST. NO. 1 ILLINOIS FED. AID PROJECT TE-001 (872)				

J:\PROJECTS\005\0745-VILLAGE OF OAK BROOK\008-22ND STREET ITEP ENHANCEMENTS\H GRAPHICS\05-DD-CD\17-20-CONSTRUCTION DETAILS.DWG 20
 Plotted: 12/16/2011 12:43 PM By: TKMC
 Copyright © 2011, By: Hitchcock Design Group

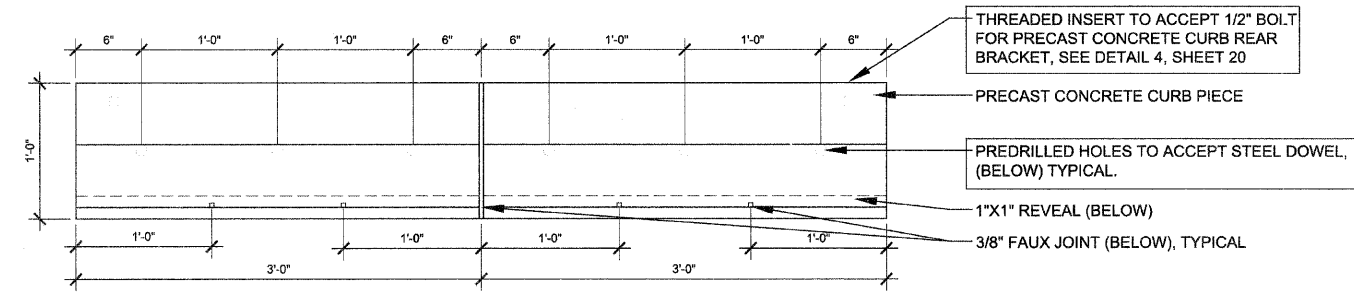

PLAN

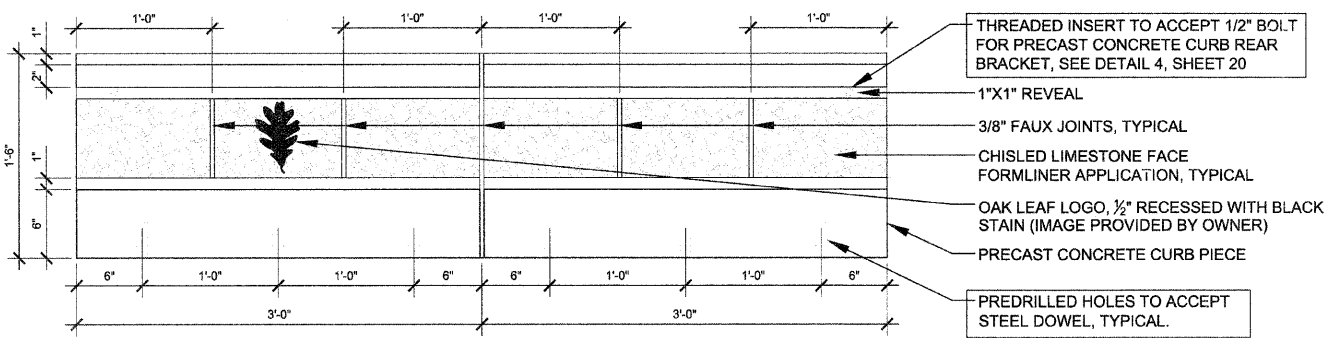

ELEVATION

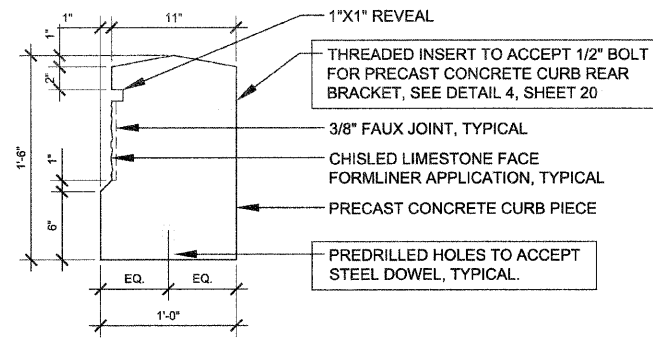

SECTION

1 PRECAST CONCRETE CURB - PIECE 1
 SCALE: 1 1/2" = 1'-0" D-PRECAST-MEDIAN-A

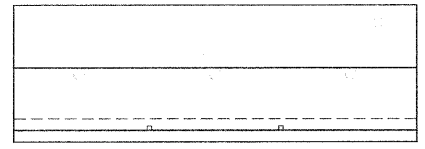

PLAN

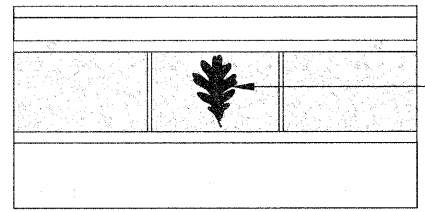

ELEVATION

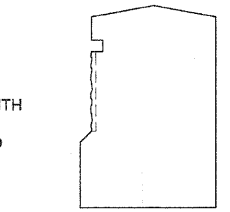

SECTION

2 PRECAST CONCRETE CURB - PIECE 2
 SCALE: 1 1/2" = 1'-0" D-PRECAST-MEDIAN-B



DESIGNED - MEU	REVISED -
DRAWN - BLG	REVISED -
CHECKED - TCK	REVISED -
DATE - 12-19-11	REVISED -

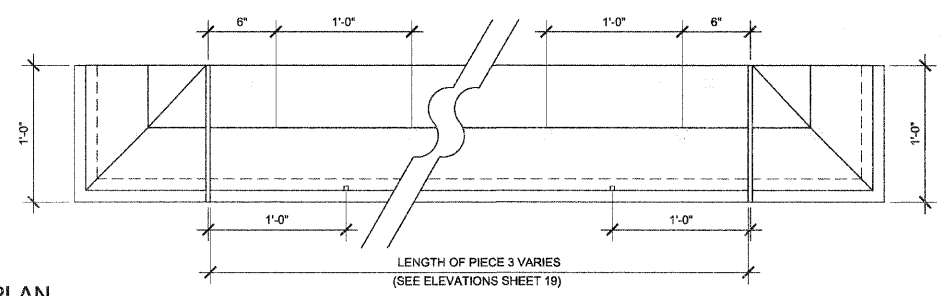

PLAN

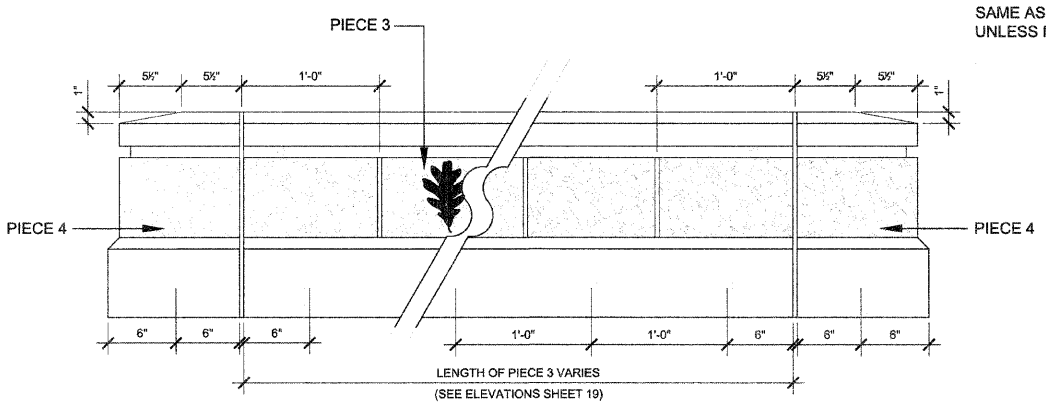

ELEVATION

NOTE: ALL NOTES AND DIMENSIONS THE SAME AS PRECAST CONCRETE CURB PIECE 1 UNLESS NOTED OTHERWISE

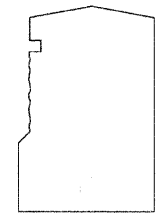

SECTION

3 PRECAST CONCRETE CURB - PIECES 3 AND 4
 Scale: 1 1/2" = 1'-0" D-PRECAST-MEDIAN-NOSE-END

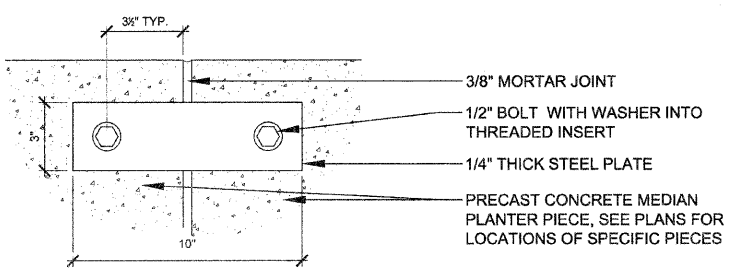

ELEVATION

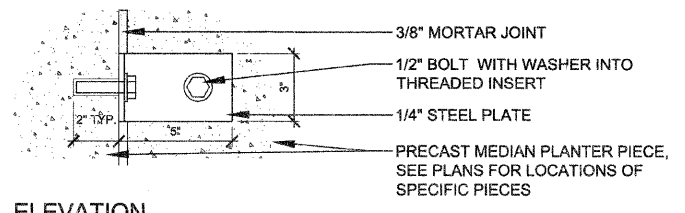

ELEVATION

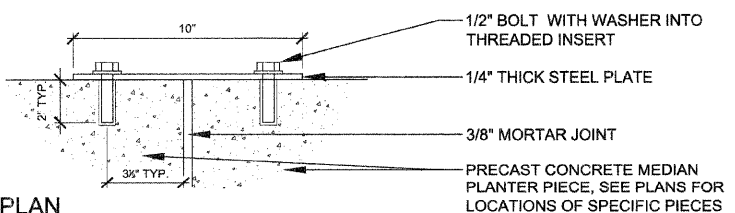

PLAN

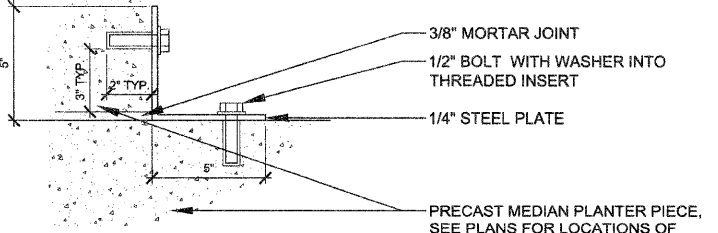

PLAN

STRAIGHT

CORNER

4 PRECAST CONCRETE CURB - CONNECTION BRACKETS
 SCALE: 3" = 1'-0" D-PRECAST-BRACKETS

STATE OF ILLINOIS
 DEPARTMENT OF TRANSPORTATION

CONSTRUCTION DETAILS

SCALE: AS SHOWN PROJECT: 03-0745-008

F.A.U. RTE.	SECTION	COUNTY	TOTAL SHEETS	SHEET NO.
1453	11-00043-00-LS	DUPAGE	20	20
CONTRACT 63663				
FED. ROAD DIST. NO. 1 ILLINOIS FED. AID PROJECT TE-0301 (872)				