

AGRICULTURAL ACCESS DETAILS

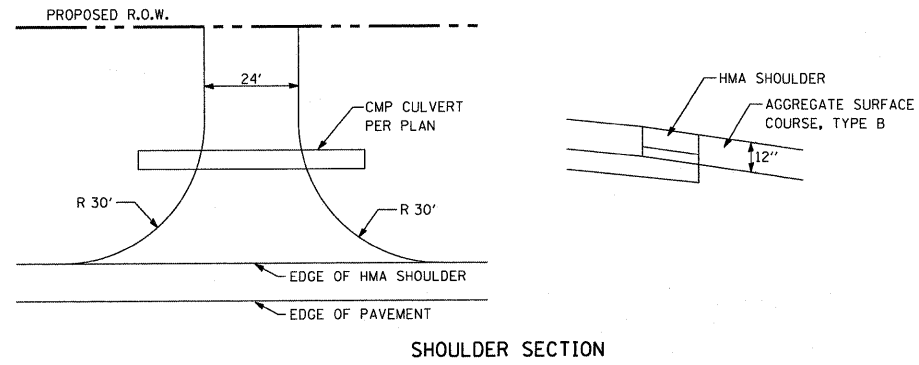

SHOULDER SECTION

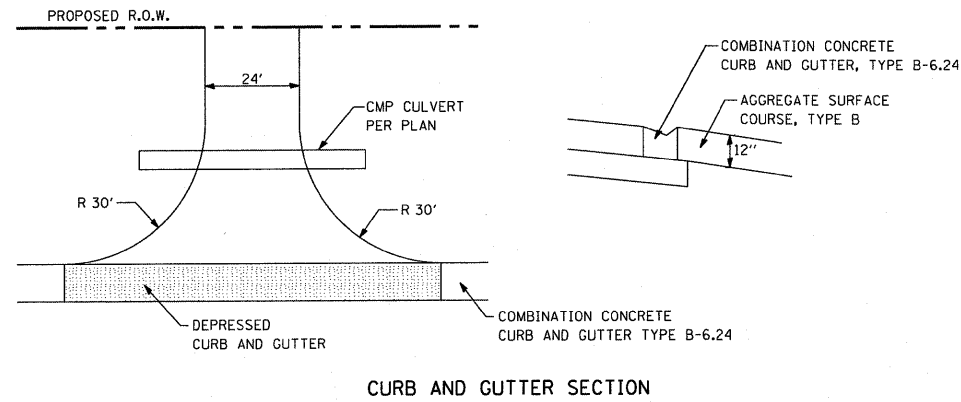

CURB AND GUTTER SECTION

PRIVATE ACCESS DETAILS

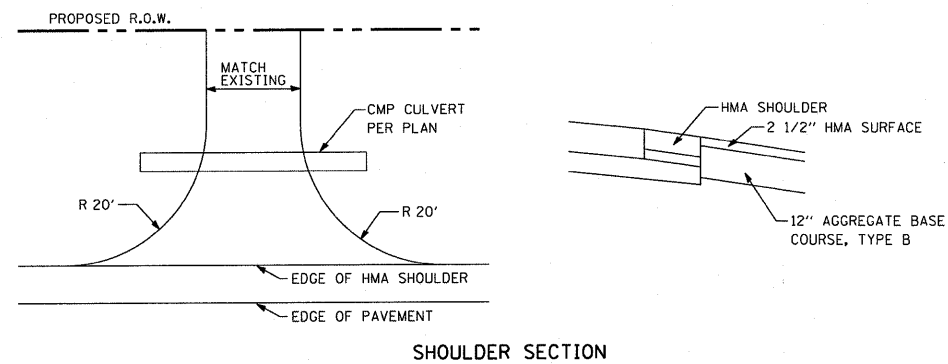

SHOULDER SECTION

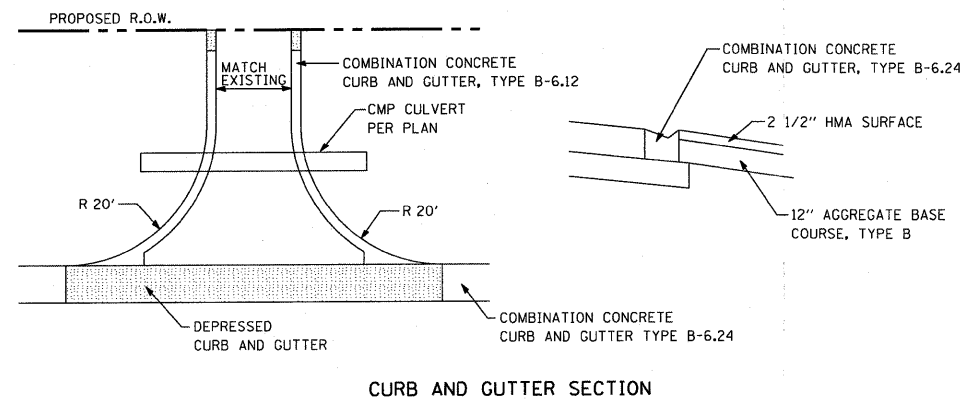

CURB AND GUTTER SECTION

COMMERCIAL ENTRANCE DETAILS

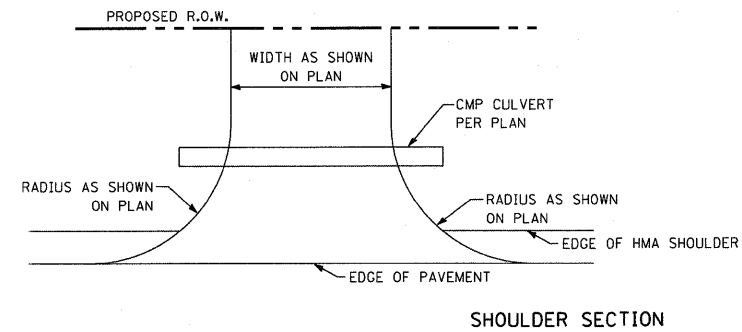

SHOULDER SECTION

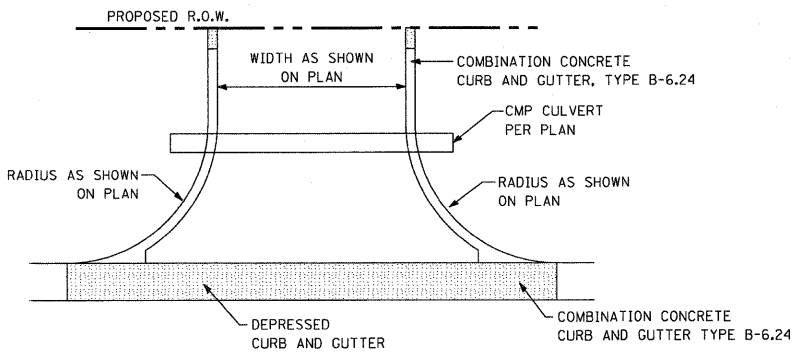

CURB AND GUTTER SECTION

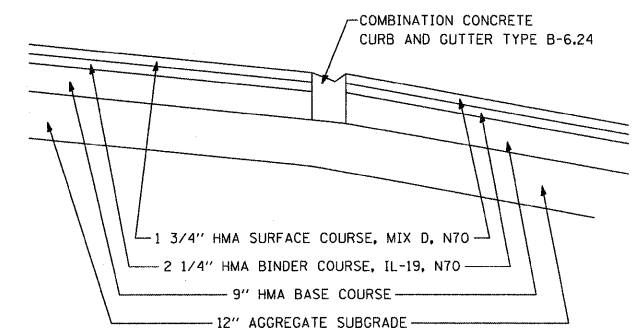
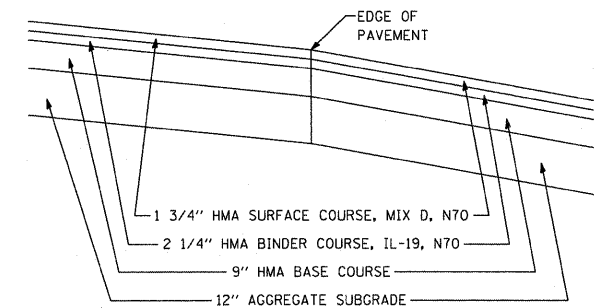

FILE NAME = P:\070116\cad\phase 2\dwg\070116-shr-det11a.dgn	USER NAME = #USER#	DESIGNED - CM	REVISED -	STATE OF ILLINOIS DEPARTMENT OF TRANSPORTATION		DRIVEWAY DETAILS		F.A.U. RTE. 324	SECTION 04-00036-22-TL	COUNTY WILL	TOTAL SHEETS 152	SHEET NO. 67	
PLOT SCALE = #SCALE#	PLOT DATE = 12/28/2011	DRAWN - JM	REVISED -			SCALE: NONE	SHEET NO. 1 OF 1 SHEETS	STA. TO STA.	CONTRACT NO. 63671				
		CHECKED - CM	REVISED -			ILLINOIS FED. AID PROJECT							
		DATE - FEBRUARY 2009	REVISED -										