

**STATE OF ILLINOIS**  
**DEPARTMENT OF TRANSPORTATION**  
**DIVISION OF HIGHWAYS**  
**PROPOSED**  
**HIGHWAY PLANS**

F.A.P. RTE.	SECTION	COUNTY	TOTAL SHEETS	SHEET NO.
330	(1,1R-2)RS	KANKAKEE	54	1
		ILLINOIS	CONTRACT NO. 66477	

**INDEX OF SHEETS**

- 1 COVER SHEET
- 2 GENERAL NOTES
- 3 - 5 SUMMARY OF QUANTITIES
- 6 - 10 TYPICAL SECTIONS
- 11 - 16 SCHEDULE OF QUANTITIES
- 17 - 33 PLAN VIEW
- 34 - 49 DETECTOR LOOP INFORMATION
- 50 - 54 DETAILS

**STANDARDS**

- 000001-06 STANDARD SYMBOLS, ABBREVIATIONS AND PATTERNS
- 001006 DECIMAL OF AN INCH AND OF A FOOT
- 424001-06 PERPENDICULAR CURB RAMPS FOR SIDEWALKS
- 424006 DIAGONAL CURB RAMPS FOR SIDEWALKS
- 424011 CORNER PARALLEL CURB RAMPS FOR SIDEWALKS
- 424016 MID-BLOCK CURB RAMPS FOR SIDEWALKS
- 424021 DEPRESSED CORNER FOR SIDEWALKS
- 424026 ENTRANCE / ALLEY PEDESTRIAN CROSSINGS
- 424031 MEDIAN PEDESTRIAN CROSSINGS
- 442201-03 CLASS C AND D PATCHES
- 606001-04 CONCRETE CURB TYPE B AND COMBINATION CONCRETE CURB AND GUTTER
- 701602-05 URBAN LANE CLOSURE, MULTILANE, 2W WITH BIDIRECTIONAL LEFT TURN LANE
- 701801-05 LANE CLOSURE, MULTILANE 1W OR 2W CROSSWALK OR SIDEWALK CLOSURE
- 701901-02 TRAFFIC CONTROL DEVICES
- 780001-03 TYPICAL PAVEMENT MARKINGS
- 781001-03 TYPICAL APPLICATIONS RAISED REFLECTIVE PAVEMENT MARKERS
- 886001-01 DETECTOR LOOP INSTALLATIONS
- 886006-01 TYPICAL LAYOUT FOR DETECTION LOOPS

**F.A.P. ROUTE 330 (IL 17)**  
**SECTION (1,1R-2)RS**  
**PROJECT: ACF-0330(067)**  
**3P RESURFACING, SIDEWALK RAMPS**  
**KANKAKEE COUNTY**

C-93-122-04

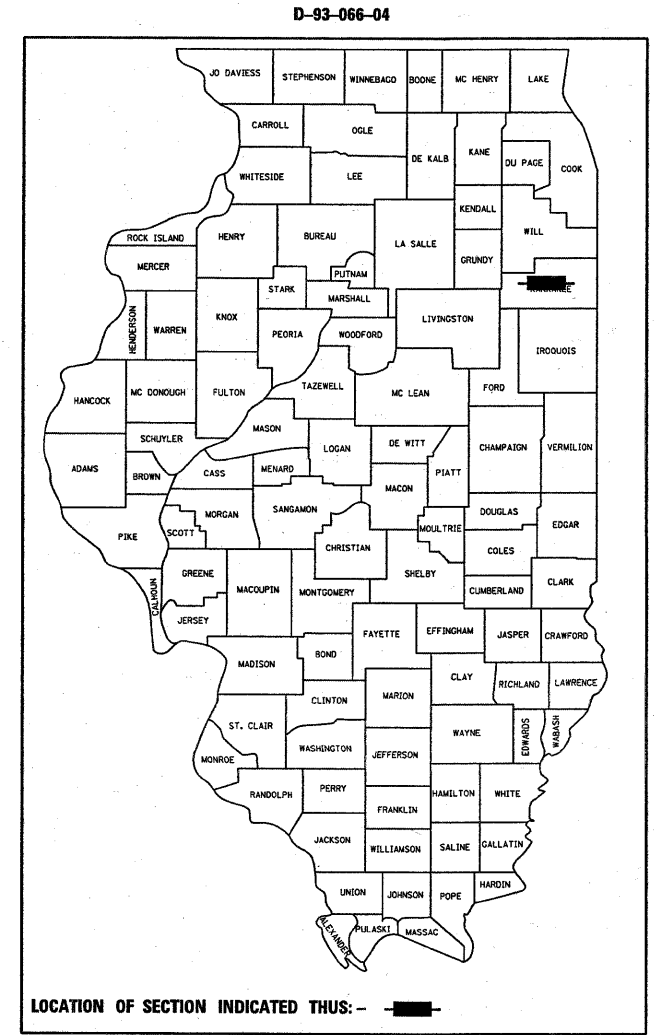

**ILLINOIS RT 17**  
**BEGIN IMPROVEMENT**  
**STA 138+00**

**STATION EQUATION**  
**STA 249+19.06 BK =**  
**STA 3+83.36 AH**

**ILLINOIS RT 17**  
**END IMPROVEMENT**  
**STA 66+50**

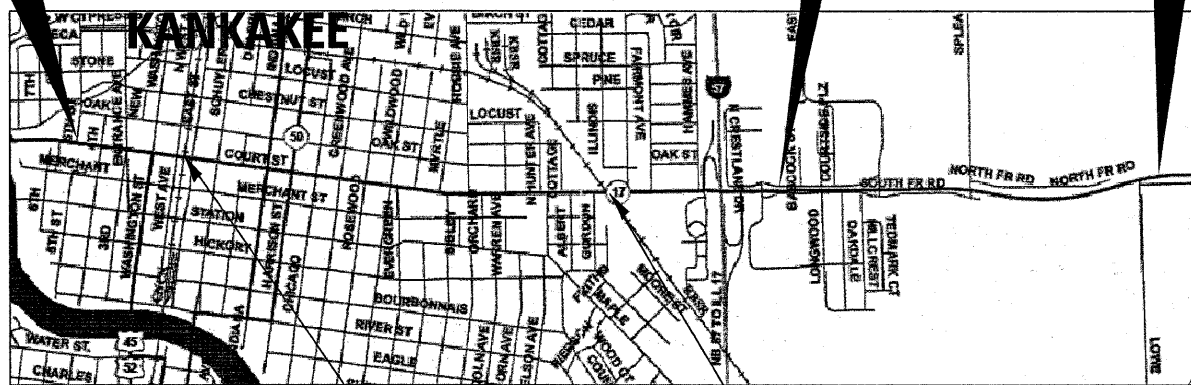

**PAVING OMISSIONS**

— STA 152+00 - 159+00  
 SN 046-0124

— STA 221+01 - 221+17

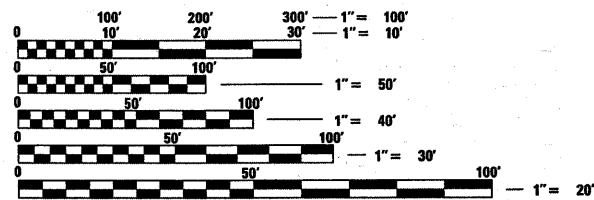

FULL SIZE PLANS HAVE BEEN PREPARED USING STANDARD ENGINEERING SCALES. REDUCED SIZED PLANS WILL NOT CONFORM TO STANDARD SCALES. IN MAKING MEASUREMENTS ON REDUCED PLANS, THE ABOVE SCALES MAY BE USED.

J.U.L.I.E.  
 JOINT UTILITY LOCATION INFORMATION FOR EXCAVATION  
 1-800-892-0123  
 OR 811

**PROJECT ENGINEER CRAIG REED, P.E.**  
**PROJECT MANAGER MARK JONES, P.E.**

**CONTRACT NO. 66477**

GROSS LENGTH = 17,285.18 FT. = 3.274 MILE  
 NET LENGTH = 17,269.18 FT. = 3.271 MILE

**OTHER PRINCIPAL ARTERIAL**  
 ADT 2009 = 15,500 AT IL 50  
 HCV=9.19%, SU=6.45%, MU=2.74%  
 ADT 2009 = 20,000 AT NELSON AVE  
 HCV=7.0%, SU=4.75%, MU=2.25%  
 ADT 2009 = 12,600 AT LOWE RD  
 HCV=9.19%, SU=6.45%, MU=2.74%

STATE OF ILLINOIS  
 DEPARTMENT OF TRANSPORTATION  
 DIVISION OF HIGHWAYS

SUBMITTED December 21 20 11  
Eric S. Therkildsen  
 DEPUTY DIRECTOR OF HIGHWAYS, REGION ENGINEER

February 3 20 12  
John D. Baranzelli P.E.  
 acting ENGINEER OF DESIGN AND ENVIRONMENT

February 3 20 12  
William R. Fien  
 acting DIRECTOR OF HIGHWAYS, CHIEF ENGINEER

**PRINTED BY THE AUTHORITY**  
**OF THE STATE OF ILLINOIS**

**GENERAL NOTES**

THE THICKNESS OF HMA SHOWN ON THE PLANS IS THE NOMINAL THICKNESS. DEVIATIONS FROM THE NOMINAL THICKNESS WILL BE PERMITTED WHEN SUCH DEVIATIONS OCCUR DUE TO IRREGULARITIES IN THE EXISTING SURFACE OR BASE ON WHICH THE HMA IS PLACED.

THE HMA SURFACE OF ALL MAILBOX TURNOUTS, PRIVATE ENTRANCES, COMMERCIAL ENTRANCES, AND SIDE ROADS SHALL BE MADE NEATLY, IN A WORKMANLIKE MANNER, AND SHALL ACCURATELY CONFORM TO THE SHAPES AND DIMENSIONS SHOWN ON THE PLAN DETAILS. IF REQUIRED BY THE ENGINEER, THE CONTRACTOR SHALL BE REQUIRED TO SAW CUT THE HMA SURFACE TO CONFORM TO THE SHAPES AND DIMENSIONS SHOWN ON THE PLAN DETAILS. THIS WORK SHALL BE INCLUDED IN THE COST OF THE HMA SURFACE.

THE ENGINEER WILL BE THE SOLE JUDGE CONCERNING CURING TIME FOR THE VARIOUS HMA LIFTS.

FOR STABILIZATION, ALL TYPE III BARRICADES SHALL REQUIRE A MINIMUM OF FOUR SAND BAGS PER BARRICADE.

THE FINISHED EARTHWORK SHALL HAVE A VEGETATION SUSTAINING SOIL COVERING THE TOP FOUR INCHES ( 100 MILLIMETERS) IN AREAS TO BE SEEDED OR SODDED. THE VEGETATION SUSTAINING SOIL REQUIRED WILL NOT BE PAID FOR SEPARATELY BUT SHALL BE INCLUDED IN THE COST OF FURNISHED EXCAVATION.

SHORT TERM PAVEMENT MARKING SHALL BE USED TO OUTLINE EXIT AND ENTRANCE RAMPS FOR THE PRIME COAT APPLICATION AND EACH RESURFACING LIFT.

FOR NEW CONSTRUCTION, PLACE CURB RAMPS FOR SIDEWALKS AT ALL LOCATIONS WHERE PROPOSED SIDEWALK ABUTS CURB AT STREET ENTRANCES

ON EXISTING PAVEMENT WHICH MAY BE SUPERELEVATED, THE NEW HMA PAVEMENT SHALL BE BUILT WITH THE SAME SUPERELEVATION UNLESS NEW SUPERELEVATION RATES ARE GIVEN ON THE PLANS.

ANY REFERENCE TO A STANDARD IN THESE PLANS SHALL BE INTERPRETED TO MEAN THE EDITION AS INDICATED BY THE SUBNUMBER SHOWN IN THE LIST OF STANDARDS OR THE COPY INCLUDED IN THESE PLANS.

THE FOLLOWING RATES OF APPLICATION HAVE BEEN USED IN CALCULATING PLAN QUANTITIES:

GRANULAR MATERIALS	2.05	TONS / CU YD
AGGREGATE (PRIME COAT)	0.002	TONS / SQ YD
HMA RESURFACING	112	LBS / SQ YD / IN
SHORT TERM PAVEMENT MARKING	10	FT /100 FT OF APPLICATION
MIX FOR CRACKS, JTS & FLGWYS	0.0003	TONS / SQ YD
LEVEL BINDER (HAND METHOD)	0.0005	TONS / SQ YD
SUPPLEMENTAL WATERING	3	GAL / SQ YD / APPLICATION
CALCIUM CHLORIDE	2	LB / SQ YD / APPLICATION
AGGREGATE DITCH CHECKS	5	TONS AGGREGATE

BITUMINOUS MATERIALS (PRIME COAT) RATES		
SURFACE TYPE	ESTIMATED TRUCK APPLICATION RATE	RESIDUAL RATE
AGGREGATE BASES	0.375 GAL / SQ YD	N/A
MILLED HMA OR PCC PAVEMENT	0.08 GAL / SQ YD	0.04 GAL / SQ YD
EXISTING PAVEMENT	0.05 GAL / SQ YD	0.025 GAL / SQ YD
FOG COAT (BETWEEN ADDITIONAL HMA LIFTS)	0.05 GAL / SQ YD	0.025 GAL / SQ YD

ESTIMATED TRUCK APPLICATION RATE USED FOR CALCULATING PLAN QUANTITIES

THE CONTRACTOR SHALL CONTACT JULIE AT LEAST 48 HOURS PRIOR TO EXCAVATION TO DETERMINE WHICH UTILITIES ARE IN THE AREA.

**COMMITMENTS**

ANY SOIL EXCAVATED DURING CONSTRUCTION OF SIDEWALK ADA RAMPS SHALL REMAIN ON SITE

STATE OF ILLINOIS  
DEPARTMENT OF TRANSPORTATION  
DISTRICT THREE

PREPARED BY: Don Bonin  
DISTRICT STUDIES & PLANS ENGINEER

DATE: 12-16-11

EXAMINED BY: Harold D. King  
DISTRICT CONSTRUCTION ENGINEER

Ray D. Phillips  
DISTRICT MATERIALS ENGINEER

Bruce A. Heber  
DISTRICT OPERATIONS ENGINEER

FILE NAME =	USER NAME = quigleyml	DESIGNED -	REVISED -	<b>STATE OF ILLINOIS DEPARTMENT OF TRANSPORTATION</b>	<b>GENERAL NOTES</b>	F.A.P. RTE.	SECTION	COUNTY	TOTAL SHEETS	SHEET NO.
ct:\pwork\pwork\quigleyml\0282391\ED05684-shr\cover.dgn	DRAWN -	REVISED -	220			(1,1R-2)RS	KANKAKEE	54	2	
PLOT SCALE = 50.0000' / 1in.	CHECKED -	REVISED -	CONTRACT NO. 66477							
PLOT DATE = 12/16/2011	DATE -	REVISED -	ILLINOIS FED. AID PROJECT							
					SCALE:	SHEET NO.	OF	SHEETS	STA.	TO STA.

CODE NO.	ITEM	UNIT	TOTAL QUANTITY	URBAN	60% FED / 20% STATE
				CONSTR. CODE	
				0005	ROADWAY
20400800	FURNISHED EXCAVATION	CU YD	24		24
25000400	NITROGEN FERTILIZER NUTRIENT	POUND	4		4
25000500	PHOSPHORUS FERTILIZER NUTRIENT	POUND	4		4
25000600	POTASSIUM FERTILIZER NUTRIENT	POUND	4		4
25200110	SODDING, SALT TOLERANT	SQ YD	266		266
25200200	SUPPLEMENTAL WATERING	UNIT	2		2
40600100	BITUMINOUS MATERIALS (PRIME COAT)	GALLON	24139		24139
40600300	AGGREGATE (PRIME COAT)	TON	282		282
40600400	MIXTURE FOR CRACKS, JOINTS, AND FLANGEWAYS	TON	48		48
40600725	POLYMERIZED LEVELING BINDER (HAND METHOD), N50	TON	67		67
40600827	POLYMERIZED LEVELING BINDER (MACHINE METHOD), IL-4.75, N50	TON	3111		3111
40600895	CONSTRUCTING TEST STRIP	EACH	2		2
40600990	TEMPORARY RAMP	SQ YD	1261		1261
40603545	POLYMERIZED HOT-MIX ASPHALT SURFACE COURSE, MIX "D", N90	TON	10653		10653
40603240	POLYMERIZED HOT-MIX ASPHALT BINDER COURSE, IL-19.0, N90	TON	1617		1617
40800050	INCIDENTAL HOT-MIX ASPHALT SURFACING	TON	1054		1054
42400100	PORTLAND CEMENT CONCRETE SIDEWALK 4 INCH	SQ FT	10149		10149
42400410	PORTLAND CEMENT CONCRETE SIDEWALK 8 INCH	SQ FT	200		200
42400800	DETECTABLE WARNINGS	SQ FT	1733		1733
44000155	HOT-MIX ASPHALT SURFACE REMOVAL, 1 1/2"	SQ YD	12232		12232
44000158	HOT-MIX ASPHALT SURFACE REMOVAL, 2 1/4"	SQ YD	114198		114198
44000165	HOT-MIX ASPHALT SURFACE REMOVAL, 4"	SQ YD	11534		11534
44000500	COMBINATION CURB AND GUTTER REMOVAL	FOOT	1577		1577
44003100	MEDIAN REMOVAL	SQ FT	30		30
44000600	SIDEWALK REMOVAL	SQ FT	10344		10344
44201377	CLASS C PATCHES, TYPE II, 12 INCH	SQ YD	272		272
44201381	CLASS C PATCHES, TYPE III, 12 INCH	SQ YD	32		32
44201383	CLASS C PATCHES, TYPE IV, 12 INCH	SQ YD	162		162
44300200	STRIP REFLECTIVE CRACK CONTROL TREATMENT	FOOT	20808		20808
48101200	AGGREGATE SHOULDERS, TYPE B	TON	300		300
56109210	WATER VALVES TO BE ADJUSTED	EACH	78		78

CODE NO.	ITEM	UNIT	TOTAL QUANTITY	URBAN	001.FED./201.STATE
				CONSTR. CODE	
					0005
					ROADWAY
60255500	MANHOLES TO BE ADJUSTED	EACH	80		80
60260100	INLETS TO BE ADJUSTED	EACH	90		90
60255800	MANHOLES TO BE ADJUSTED WITH NEW TYPE 1 FRAME, CLOSED LID	EACH	15		15
60604400	COMBINATION CONCRETE CURB AND GUTTER, TYPE B-6.18	FOOT	1352		1352
60605000	COMBINATION CONCRETE CURB AND GUTTER, TYPE B-6.24	FOOT	200		200
60610400	COMBINATION CONCRETE CURB AND GUTTER, TYPE M-6.24	FOOT	25		25
X8140115	HANDHOLE TO BE ADJUSTED	EACH	24		24
66700205	PERMANENT SURVEY MARKERS, TYPE I	EACH	3		3
67000400	ENGINEER'S FIELD OFFICE, TYPE A	CAL MO	5		5
67100100	MOBILIZATION	L SUM	1		1
70100320	TRAFFIC CONTROL AND PROTECTION, STANDARD 701422	L SUM	1		1
70102632	TRAFFIC CONTROL AND PROTECTION, STANDARD 701602	L SUM	1		1
70102635	TRAFFIC CONTROL AND PROTECTION, STANDARD 701701	L SUM	1		1
70102640	TRAFFIC CONTROL AND PROTECTION, STANDARD 701801	L SUM	1		1
70106800	CHANGEABLE MESSAGE SIGN	CAL MO	12		12
<del>70200100</del>	<del>NIGHTTIME WORKZONE LIGHTING</del>	<del>L SUM</del>	<del>1</del>		<del>1</del>
70300100	SHORT-TERM PAVEMENT MARKING	FOOT	15377		15377
70300210	TEMPORARY PAVEMENT MARKING- LETTERS AND SYMBOLS	SQ FT	2379		2379
70300220	TEMPORARY PAVEMENT MARKING- LINE 4"	FOOT	52203		52203
70300240	TEMPORARY PAVEMENT MARKING- LINE 6"	FOOT	17544		17544
70300250	TEMPORARY PAVEMENT MARKING- LINE 8"	FOOT	5150		5150
70300260	TEMPORARY PAVEMENT MARKING- LINE 12"	FOOT	6781		6781
70300280	TEMPORARY PAVEMENT MARKING- LINE 24"	FOOT	2135		2135
70301000	WORK ZONE PAVEMENT MARKING REMOVAL	SQ FT	1510		1510
78000200	THERMOPLASTIC PAVEMENT MARKING - LINE 4"	FOOT	52203		52203
78000500	THERMOPLASTIC PAVEMENT MARKING - LINE 8"	FOOT	5150		5150
78000600	THERMOPLASTIC PAVEMENT MARKING - LINE 12"	FOOT	6781		6781
78003100	PREFORMED PLASTIC PAVEMENT MARKING, TYPE B - LETTERS AND SYMBOLS	SQ FT	2379		2379
78003180	PREFORMED PLASTIC PAVEMENT MARKING, TYPE B - LINE 24"	FOOT	2135		2135
78004230	PREFORMED PLASTIC PAVEMENT MARKING, TYPE B - INLAID - LINE 6"	FOOT	17544		17544
78100100	RAISED REFLECTIVE PAVEMENT MARKER	EACH	1548		1548
78300200	RAISED REFLECTIVE PAVEMENT MARKER REMOVAL	EACH	1548		1548
88600100	DETECTOR LOOP, TYPE I	FOOT	12655		12655

• SPECIALTY ITEMS

FILE NAME =	USER NAME = quigleyml	DESIGNED -	REVISED -	<b>STATE OF ILLINOIS DEPARTMENT OF TRANSPORTATION</b>	<b>SUMMARY OF QUANTITIES</b>				F.A.P RTE.	SECTION	COUNTY	TOTAL SHEETS	SHEET NO.
ct:\pw\work\p\dot\quigleyml\20282391\ED06604-sht-schedule.dgn	PLOT SCALE = 50.0000' / 1".	DRAWN -	REVISED -						330	(1,1R-2)RS	KANKAKEE	54	4
	PLOT DATE = 12/20/2011	CHECKED -	REVISED -		SCALE: SHEET OF SHEETS STA. TO STA.				CONTRACT NO. 66477				
		DATE -	REVISED -		ILLINOIS FED. AID PROJECT								



CODE NO.	ITEM	UNIT	TOTAL QUANTITY	URBAN <sup>80% FED / 20% STATE</sup> CONSTR. CODE	
				0005 ROADWAY	
• X8860100	LOOP DETECTOR TESTING	EACH	13		13
• 88500500	INDUCTION LOOP DETECTOR AMPLIFIER	EACH	87		87
• 89502200	MODIFY EXISTING CONTROLLER	EACH	16		16
Z0048665	RAILROAD PROTECTIVE LIABILITY INSURANCE	L SUM	1		1
Z0034105	MATERIAL TRANSFER DEVICE	TON	14286		14286
* X7800610	URETHANE PAVEMENT MARKING - LINE 4"	FOOT	1713		1713
* X7800640	URETHANE PAVEMENT MARKING - LINE 8"	FOOT	118		118
* X7800650	URETHANE PAVEMENT MARKING - LINE 12"	FOOT	342		342
* X7830074	GROOVING FOR RECESSED PAVEMENT MARKING 7"	FOOT	634		634
* X7830076	GROOVING FOR RECESSED PAVEMENT MARKING 9"	FOOT	5268		5268
ⓐ Z0076600	<i>TRAINNEES</i>	<i>HOUR</i>	<i>2000</i>		<i>2000</i>

• SPECIALTY ITEMS  
ⓐ 0042

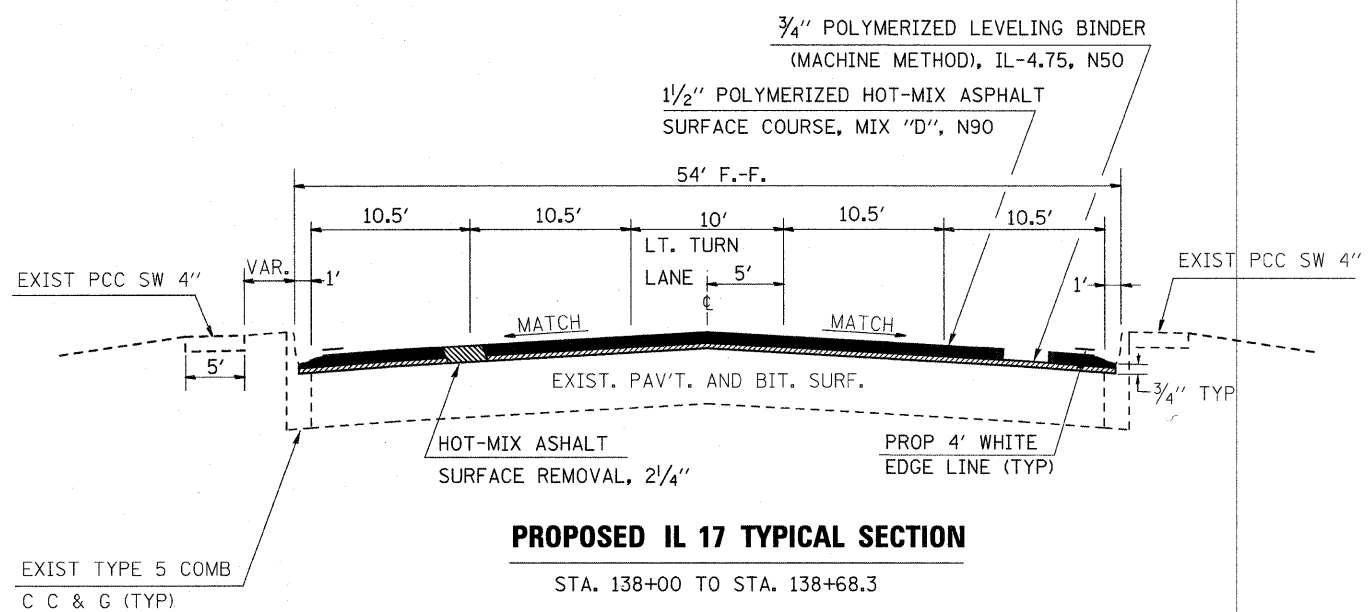

**PROPOSED IL 17 TYPICAL SECTION**  
 STA. 138+00 TO STA. 138+68.3

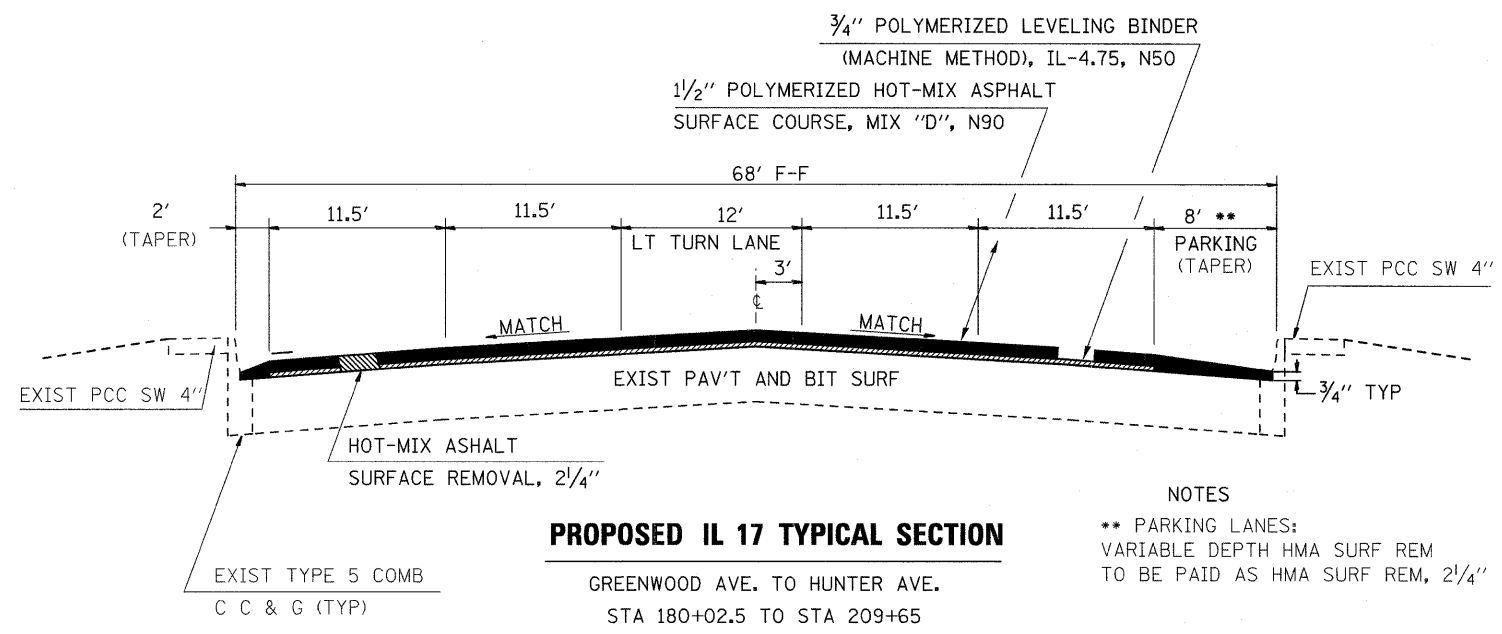

**PROPOSED IL 17 TYPICAL SECTION**  
 GREENWOOD AVE. TO HUNTER AVE.  
 STA 180+02.5 TO STA 209+65

NOTES  
 \*\* PARKING LANES:  
 VARIABLE DEPTH HMA SURF REM  
 TO BE PAID AS HMA SURF REM, 2 1/4"

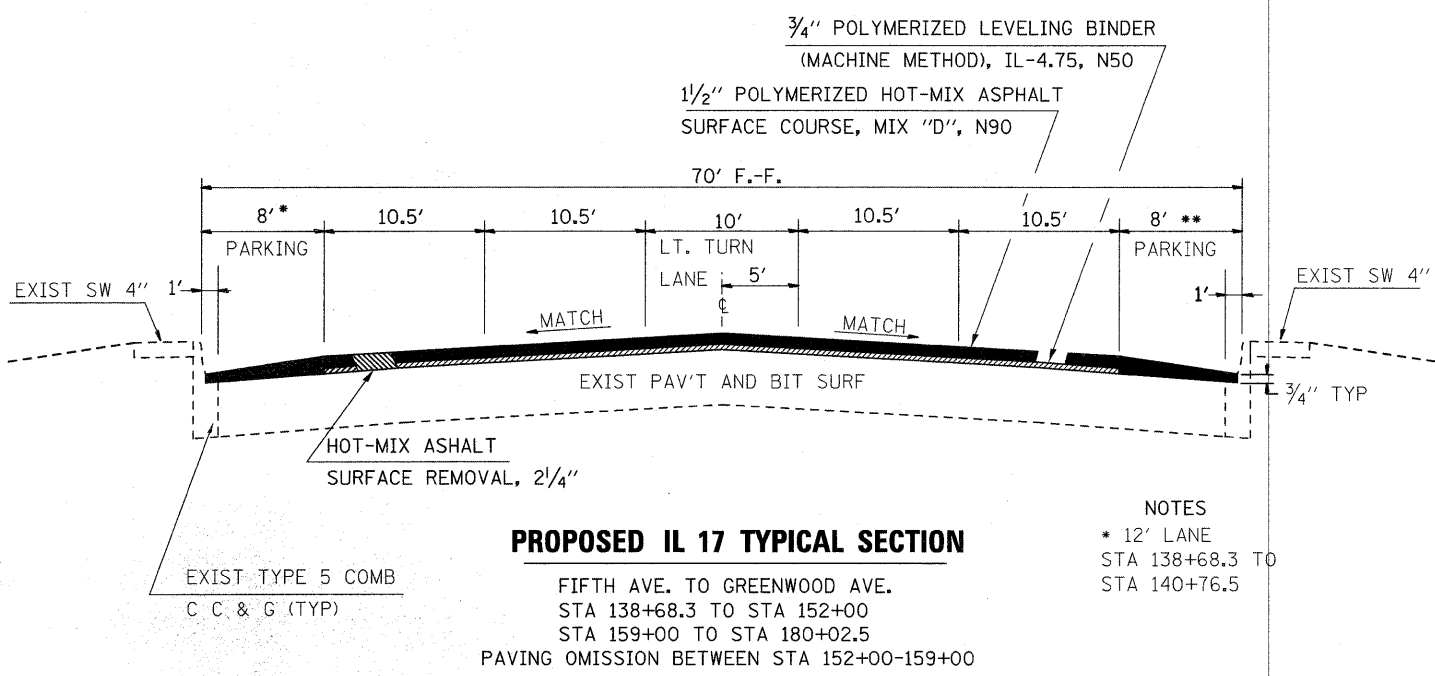

**PROPOSED IL 17 TYPICAL SECTION**  
 FIFTH AVE. TO GREENWOOD AVE.  
 STA 138+68.3 TO STA 152+00  
 STA 159+00 TO STA 180+02.5  
 PAVING OMISSION BETWEEN STA 152+00-159+00

NOTES  
 \* 12' LANE  
 STA 138+68.3 TO  
 STA 140+76.5

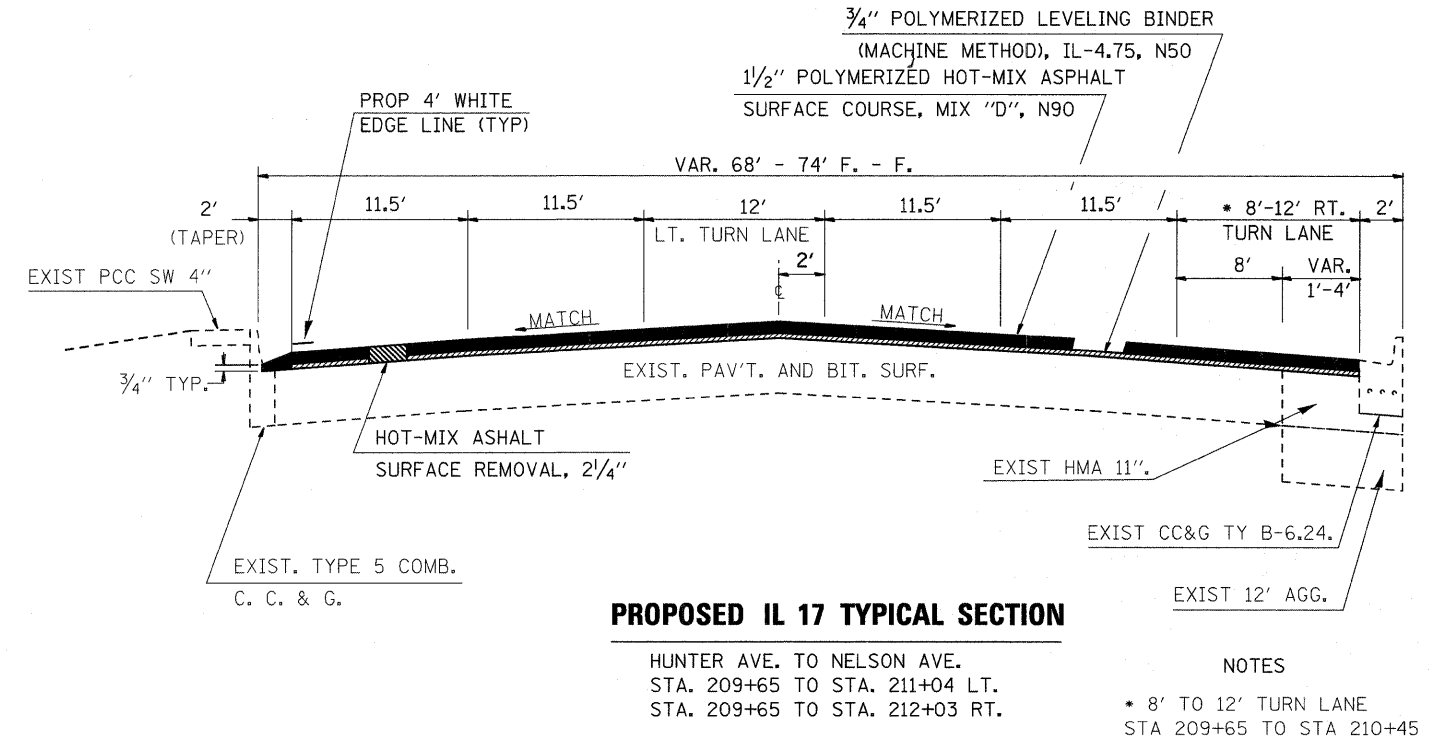

**PROPOSED IL 17 TYPICAL SECTION**  
 HUNTER AVE. TO NELSON AVE.  
 STA. 209+65 TO STA. 211+04 LT.  
 STA. 209+65 TO STA. 212+03 RT.

NOTES  
 \* 8' TO 12' TURN LANE  
 STA 209+65 TO STA 210+45

FILE NAME =	USER NAME = leaf_jw	DESIGNED -	REVISED -	<b>STATE OF ILLINOIS DEPARTMENT OF TRANSPORTATION</b>	<b>IL 17 TYPICAL SECTIONS</b>	F.A.P. RTE.	SECTION	COUNTY	TOTAL SHEETS	SHEET NO.	
c:\pw_work\pwsdot\qasgleym\1d0282391\ED06604-ahd-details.dgn	604-ahd-details.dgn	DRAWN -	REVISED -			330	(1R-2)RS	KANKAKEE	54	6	
PLOT SCALE = 50.0000' / 1"		CHECKED -	REVISED -			CONTRACT NO. 66477					
PLOT DATE = 12/20/2011		DATE -	REVISED -			ILLINOIS FED. AID PROJECT					
SCALE:						SHEET NO. OF SHEETS STA. TO STA.					

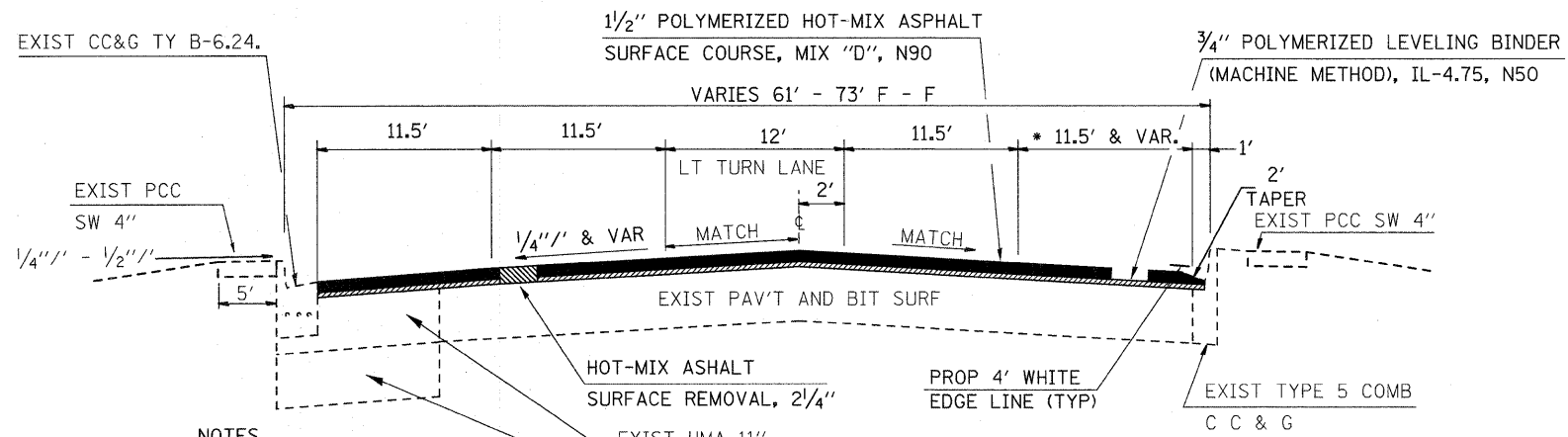

**NOTES**

- \* 13.5' STA 215+76.5 - 219+46.5  
VARIES 11.5' TO 22.5' STA 221+37 - 221+98  
(11.5' LANE PLUS VARIES 0' - 11' RT TURN LANE)
- 22.5' STA 221+98 - 224+54.5  
(11.5' LANE PLUS 11' RT TURN LANE)
- 23' STA 224+54.5 - 226+00  
(11.5' LANE)

**PROPOSED IL 17 TYPICAL SECTION**

HUNTER AVE. TO FAIRMONT AVE.  
STA. 211+04 TO STA. 226+00LT  
STA. 212+03 TO STA. 226+00 RT  
RR OMISSION BETWEEN STA 221+01-221+17

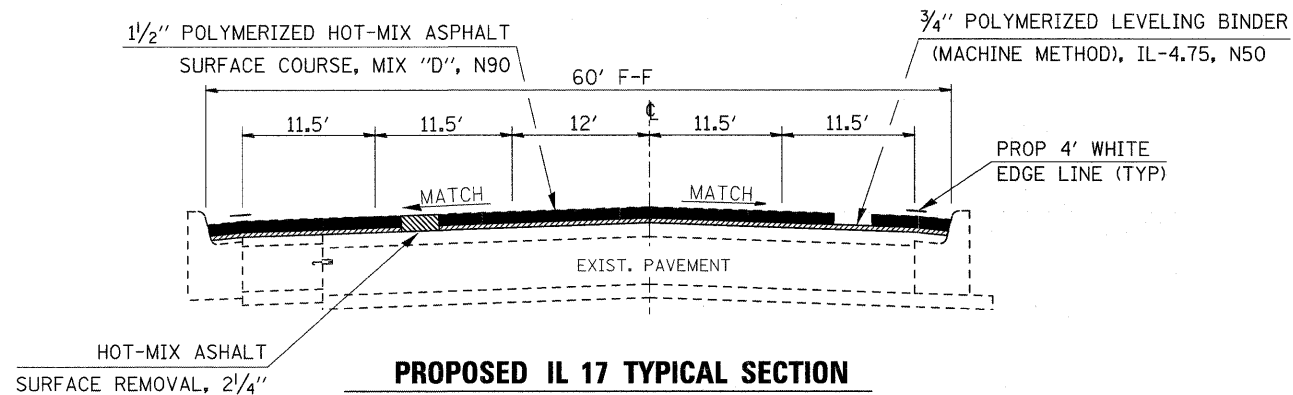

**PROPOSED IL 17 TYPICAL SECTION**

STA. 230+36 TO STA. 234+50±  
STA. 236+00± TO STA. 236+75±

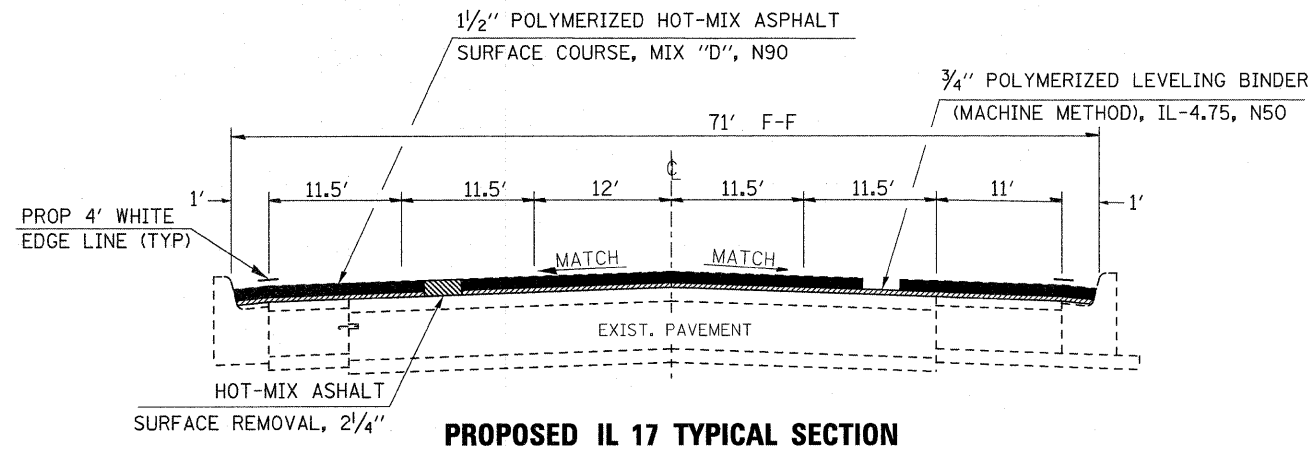

**PROPOSED IL 17 TYPICAL SECTION**

STA 226+00 TO STA 230+36

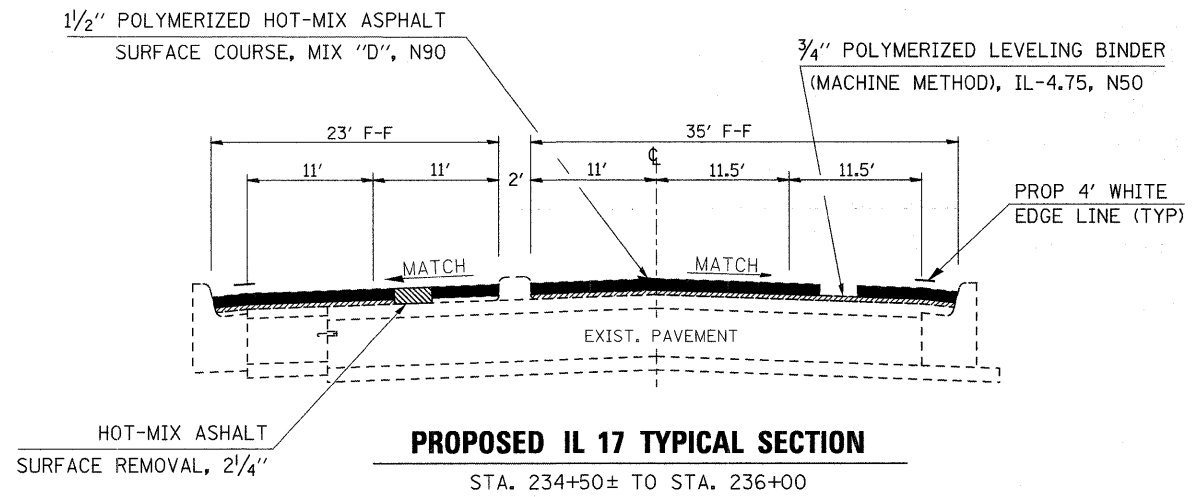

**PROPOSED IL 17 TYPICAL SECTION**

STA. 234+50± TO STA. 236+00

FILE NAME =	USER NAME = leaf_jw	DESIGNED -	REVISED -	<b>STATE OF ILLINOIS DEPARTMENT OF TRANSPORTATION</b>	<b>IL 17 TYPICAL SECTIONS</b>			F.A. P. RTE. 330	SECTION (1,1R-2)RS	COUNTY KANKAKEE	TOTAL SHEETS 54	SHEET NO. 7
cd:\pw_work\pwsdot\quigleyml\d0282391\ED006604-shr-details.dgn	PLOT SCALE = 50,0000' / 1in.	DRAWN -	REVISED -		SCALE:	SHEET NO.	OF SHEETS	STA.	TO STA.	CONTRACT NO. 66477		
	PLOT DATE = 12/20/2011	CHECKED -	REVISED -		ILLINOIS FED. AID PROJECT							
		DATE -	REVISED -									

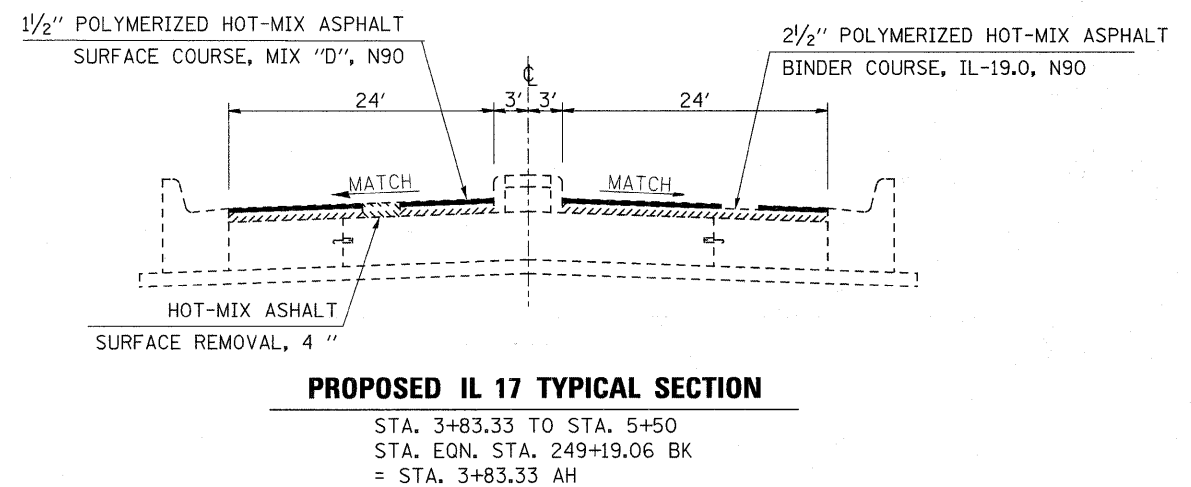
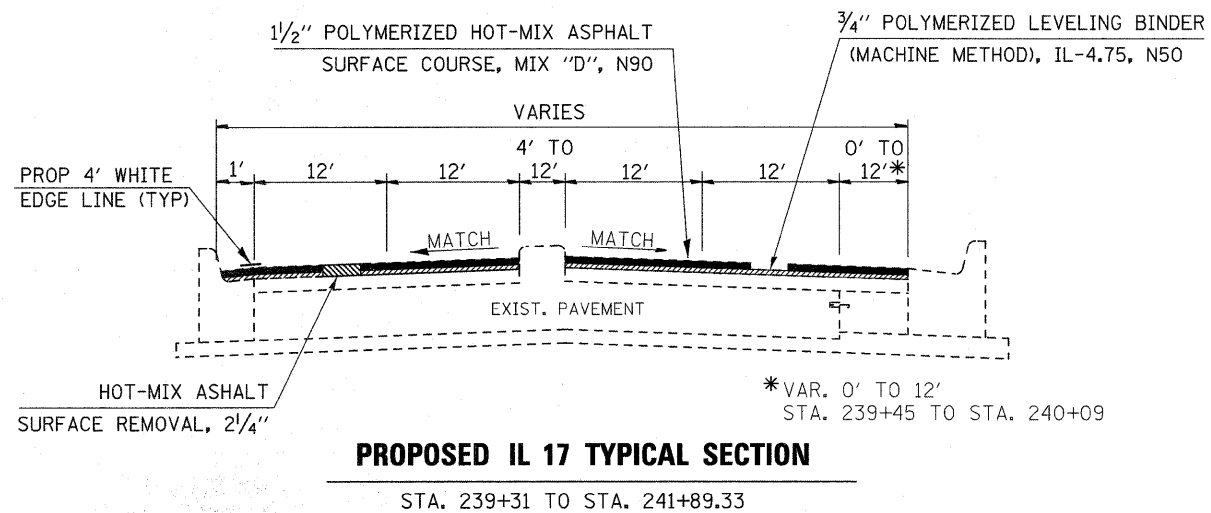
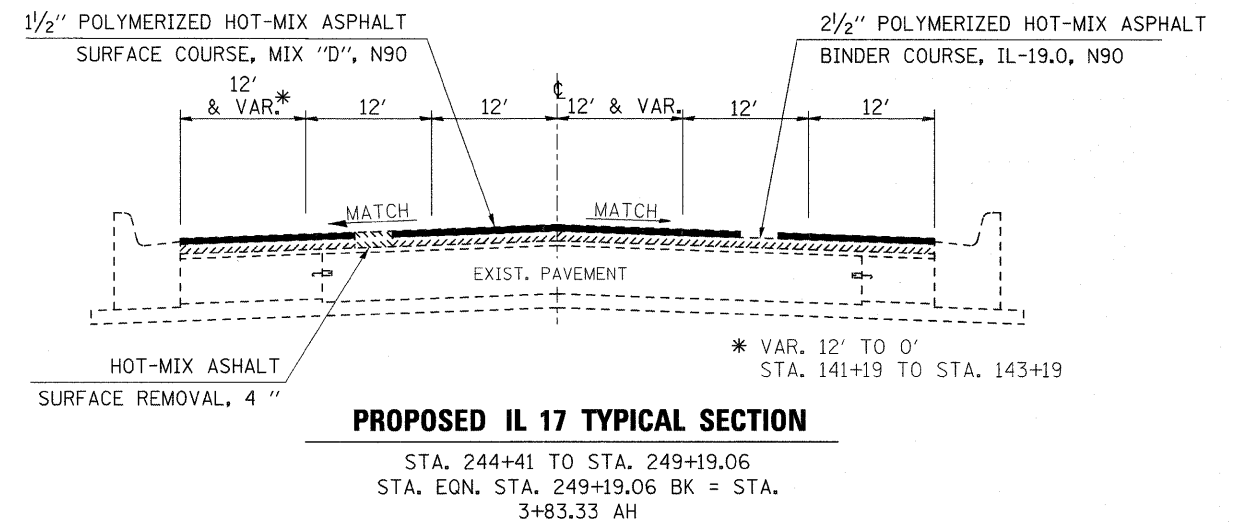
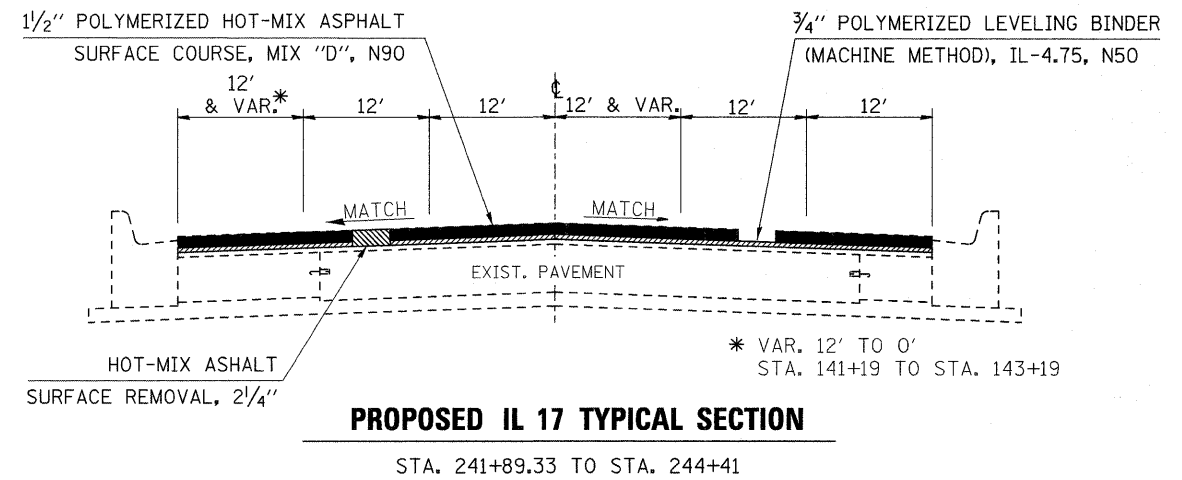
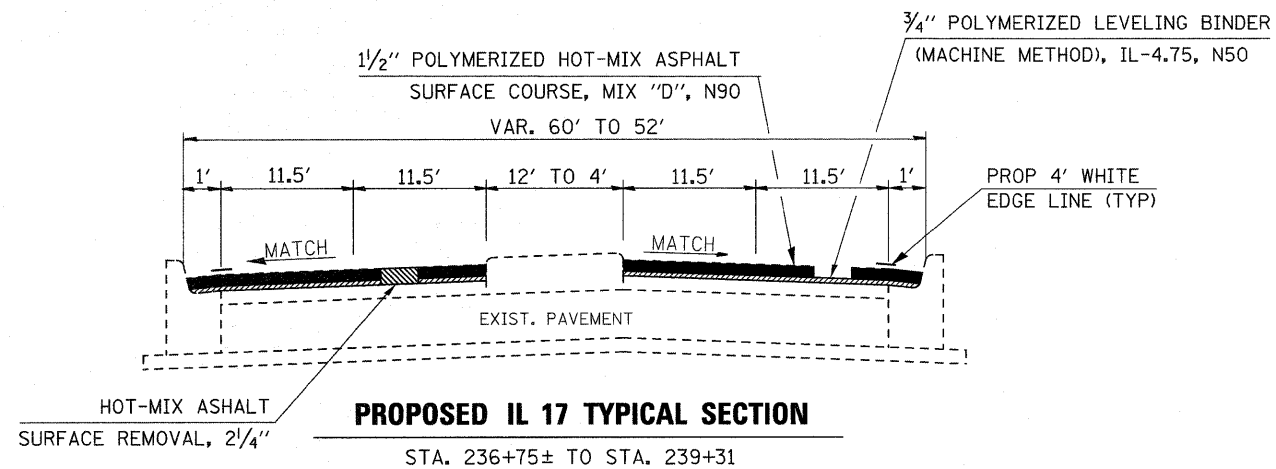

FILE NAME =	USER NAME = leaf_jw	DESIGNED -	REVISED -	<b>STATE OF ILLINOIS DEPARTMENT OF TRANSPORTATION</b>	<b>IL 17 TYPICAL SECTIONS</b>			F.A.P. RTE.	SECTION	COUNTY	TOTAL SHEETS	SHEET NO.			
c:\pwwork\pwwork\autocad\1\2022391\ED026604-shit-details.dgn	PLOT SCALE = 50.0000' / 1in.	DRAWN -	REVISED -		SCALE:	SHEET NO.	OF	SHEETS	STA.	TO STA.	330	(1,1R-2)RS	KANKAKEE	54	8
PLOT DATE = 12/20/2011	DATE -	CHECKED -	REVISED -		CONTRACT NO. 66477										
					[ILLINOIS] FED. AID PROJECT										

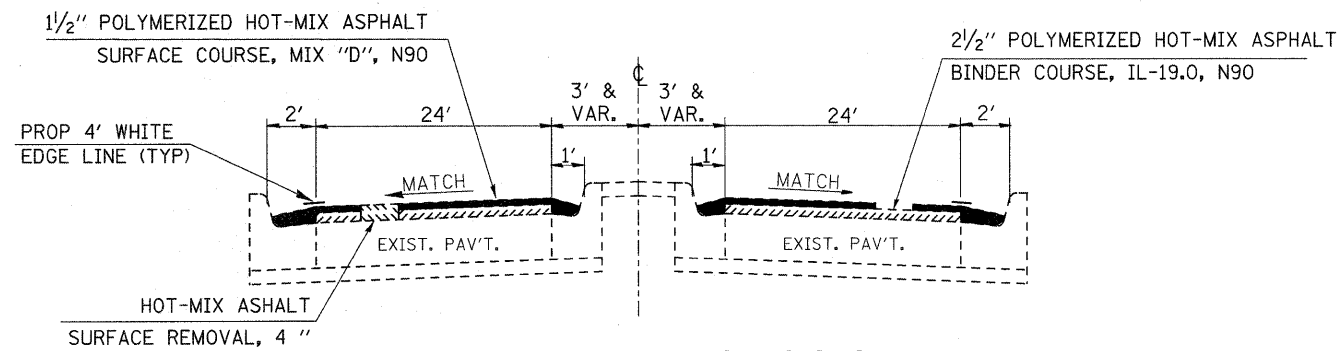

**PROPOSED IL 17 TYPICAL SECTION**

STA. 5+50 TO STA. 11+85  
STA. 20+85 TO STA. 22+64 (WBL)

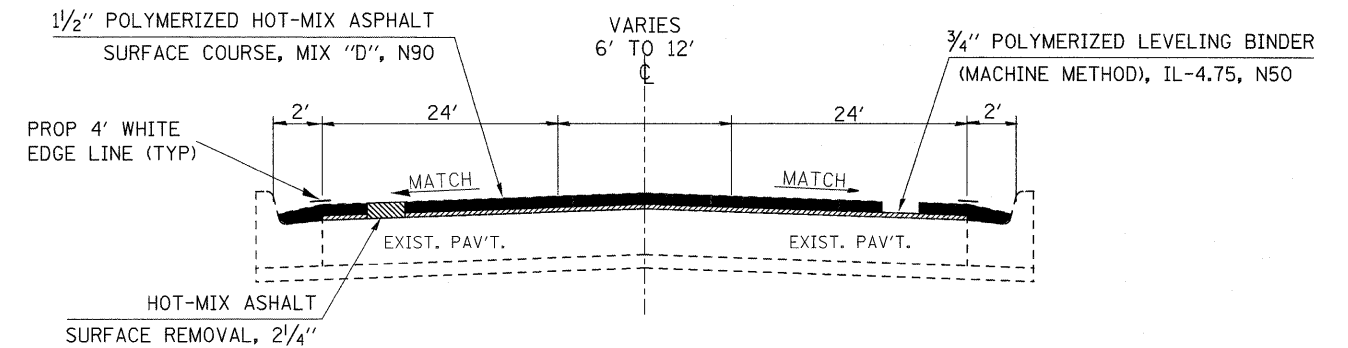

**PROPOSED IL 17 TYPICAL SECTION**

STA 17+00 TO STA 19+25

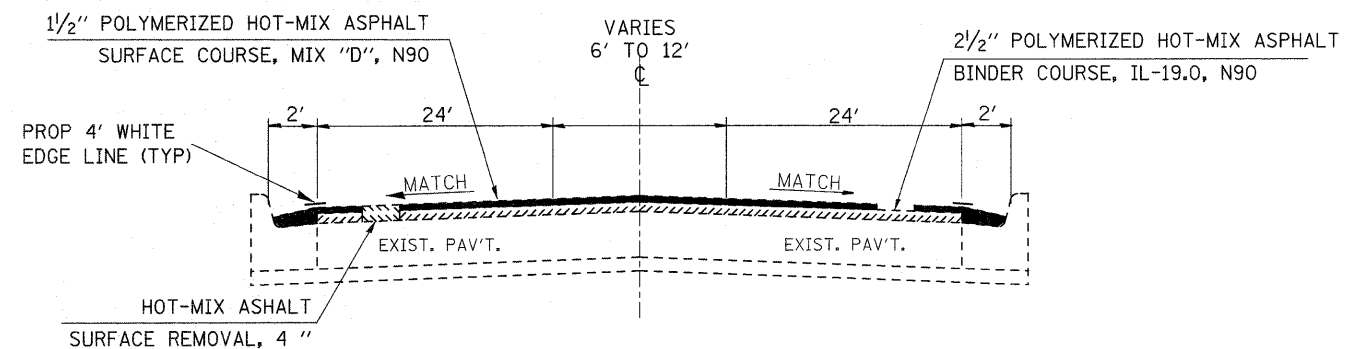

**PROPOSED IL 17 TYPICAL SECTION**

STA 11+85 TO STA 17+00

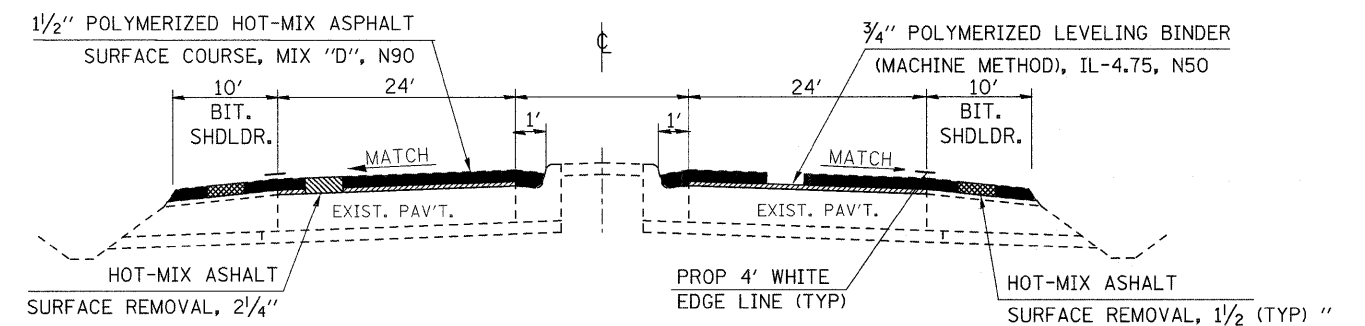

**PROPOSED IL 17 TYPICAL SECTION**

STA 19+25 TO STA 22+64 (EBL)  
STA 22+64 TO 32+26.15

FILE NAME =	USER NAME = leafjw	DESIGNED -	REVISED -	<b>STATE OF ILLINOIS DEPARTMENT OF TRANSPORTATION</b>	<b>IL 17 TYPICAL SECTIONS</b>				F.A.P. RTE.	SECTION	COUNTY	TOTAL SHEETS	SHEET NO.
ca\pw_work\pwsdot\quagleyml\d0282391\ED06604-shd-details.dgn		DRAWN -	REVISED -		330	(1, 1R-2)RS	KANKAKEE	54	9				
PLOT SCALE = 50.0000' / 1in.		CHECKED -	REVISED -		SCALE: SHEET NO. OF SHEETS STA. TO STA.				CONTRACT NO. 66477				
PLOT DATE = 12/20/2011		DATE -	REVISED -		ILLINOIS FED. AID PROJECT								

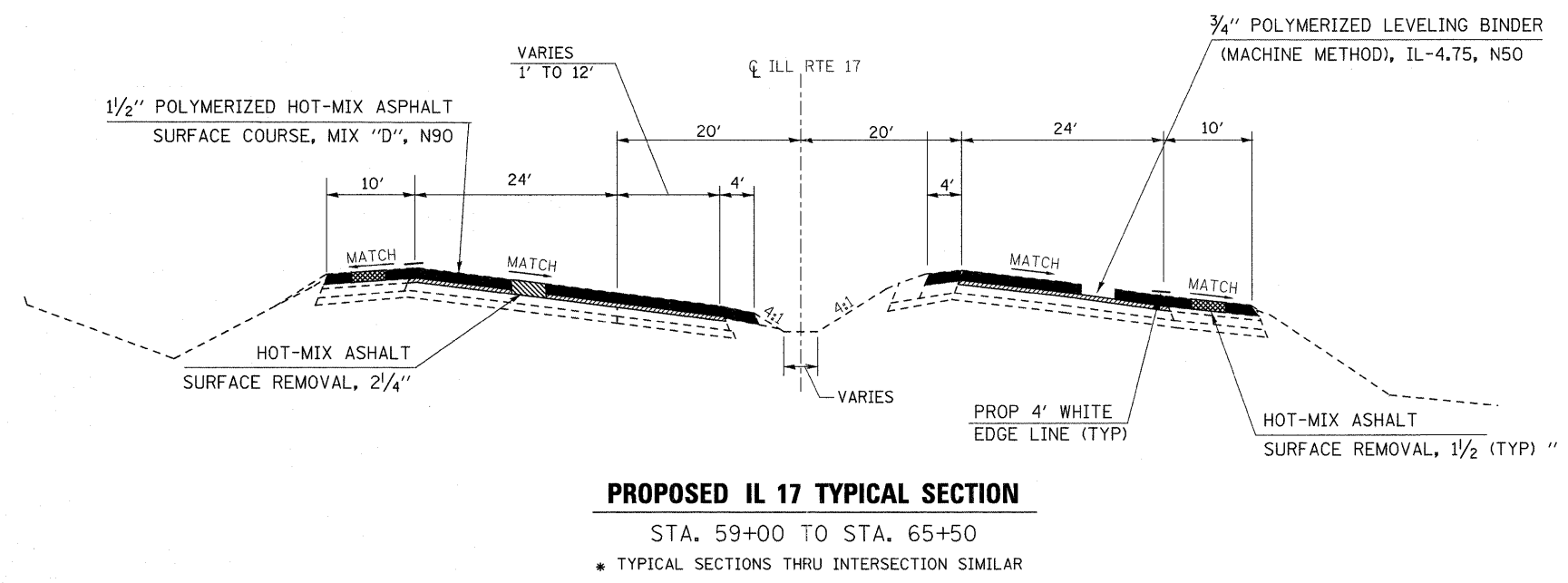
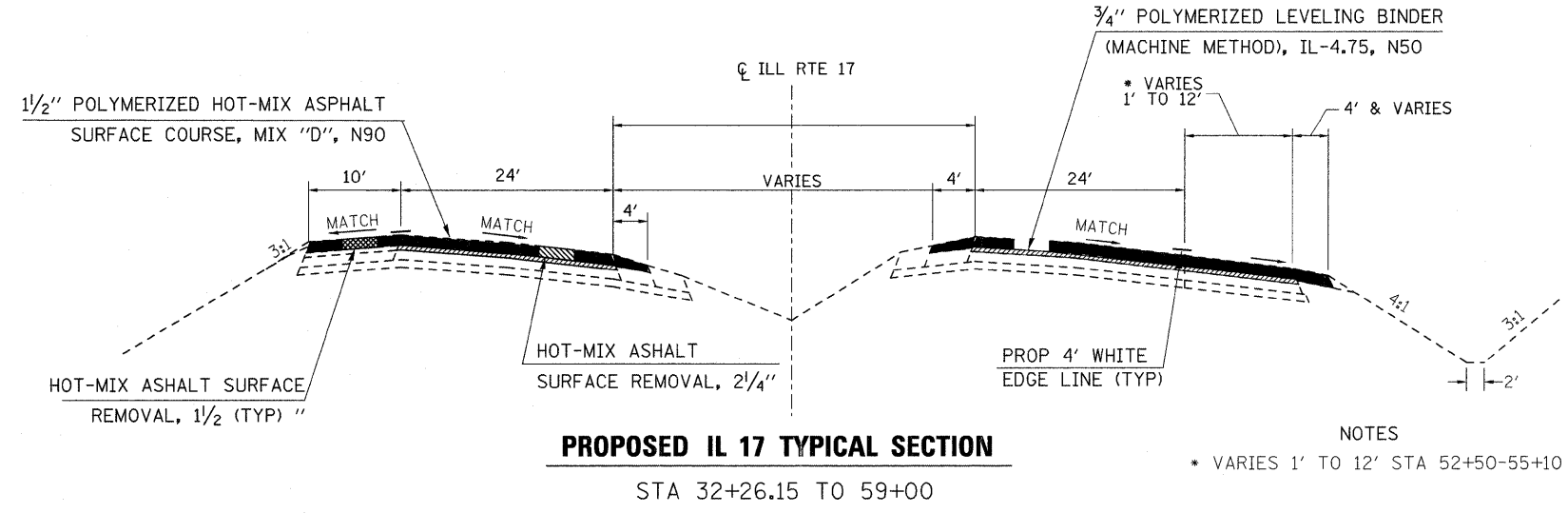

MIXTURE TABLE					
MIX	PG GRADE	DESIGN AIR Voids	FRICTION AGGREGATE	MIXTURE COMPOSITION	DENSITY TEST
HMA LEVELING BINDER	SBS PG70-22	4.0% @ N50		TI - 4.75	CORES/CORRELATION
HMA SURFACE COURSE	SBS PG70-22	4.0% @ N90	MIXTURE D	TI 9.5	CORES/CORRELATION
INCIDENTAL HMA	PG64-22	4.0% @ N50	MIXTURE C	TI 9.5	SATISFACTION OF ENGINEER





SIDEROAD SCHEDULE									
SIDEROAD	LT/RT	STATION	AREA	INCID.	BIT	AGG	TEMP	MIX CRACKS	HMA
			TOTAL	HMA	MATL	(PRIME	RAMP	JOINTS &	SURF
			SQ YD	TON	(PRIME	COAT)	COAT)	FLWY	REM
					GALLON	TON	TON	TON	1 1/2IN
									SQ YD
FIFTH AVE	LT	137+50	331	28.0	27.0	0.7	33.4	0.1	331
FIFTH AVE	RT	137+50	60	6.0	5.0	0.2	13.9	0.1	60
FIFTH AVE (2)	RT		35	3.0	3.0	0.1	5.6	0.1	35
FOURTH AVE	LT	142+10	110	10.0	9.0	0.3	16.7	0.1	110
FOURTH AVE	RT	142+10	110	10.0	9.0	0.3	16.7	0.1	110
ENTRANCE AVE	LT	146+50	393	34.0	32.0	0.8	25	0.2	393
ENTRANCE AVE	RT	146+50	202	17.0	17.0	0.5	33.4	0.1	202
WASHINGTON	LT	150+50	134	12.0	11.0	0.3	22.3	0.1	134
WASHINGTON	RT	150+50	312	27.0	25.0	0.7	27.8	0.1	312
SCHUYLER	LT	160+51	167	15.0	14.0	0.4	22.3	0.1	167
SCHUYLER	RT	160+51	154	13.0	13.0	0.4	22.3	0.1	154
DEARBORN AVE	LT	164+40	146	13.0	12.0	0.3	25	0.1	146
INDIANA AVE	LT	168+30	428	36.0	35.0	0.9	27.8	0.2	428
INDIANA AVE	RT	168+30	256	22.0	21.0	0.6	25	0.1	256
HARRISON AVE	LT	172+20	123	11.0	10.0	0.3	27.8	0.1	123
HARRISON AVE	RT	172+20	357	30.0	29.0	0.8	27.8	0.2	357
CHICAGO AVE	LT	176+12	139	12.0	12.0	0.3	19.5	0.1	139
CHICAGO AVE	RT	176+12	109	10.0	9.0	0.3	16.7	0.1	109
GREENWOOD AVE	LT	180+03	159	14.0	13.0	0.4	16.7	0.1	159
GREENWOOD AVE	RT	180+03	165	14.0	14.0	0.4	16.7	0.1	165
ROSEWOOD AVE	LT	183+92	150	13.0	12.0	0.3	16.7	0.1	150
ROSEWOOD AVE	RT	183+92	103	9.0	9.0	0.3	16.7	0.1	103
WILDWOOD AVE	LT	187+83	127	11.0	11.0	0.3	16.7	0.1	127
WILDWOOD AVE	RT	187+83	123	11.0	10.0	0.3	16.7	0.1	123
SOUTH EVERGREEN AVE	RT	188+97	132	12.0	11.0	0.3	19.5	0.1	132
NORTH EVERGREEN AVE	LT	191+73	134	12.0	11.0	0.3	16.7	0.1	134
MYRTLE AVE	LT	195+63	125	11.0	10.0	0.3	16.7	0.1	125
ELM AVE	RT	196+83	71	6.0	6.0	0.2	11.2	0.1	71
HOBBIE AVE	LT	200+04	279	24.0	23.0	0.6	22.3	0.1	279
ORCHARD AVE	RT	202+12	115	10.0	10.0	0.3	16.7	0.1	115
TAYLOR AVE	LT	205+69	117	10.0	10.0	0.3	16.7	0.1	117
HUNTER AVE	LT	211+00	290	25.0	24.0	0.6	16.7	0.1	290
NELSON AVE	RT	212+05	317	27.0	26.0	0.7	25	0.1	317
COTTAGE AVE	LT	214+35	219	19.0	18.0	0.5	19.5	0.1	219
ALBERT AVE	RT	215+77	123	11.0	10.0	0.3	19.5	0.1	123
GORDON AVE	RT	219+47	125	11.0	10.0	0.3	16.7	0.1	125
FAIRMONT AVE	LT	224+55	375	32.0	30.0	0.8	22.3	0.2	375
CE (McDonalds)	RT	224+62	100	9.0	8.0	0.2	19.5	0.1	100
ST. JOSEPH AVE	LT	228+30	132	12.0	11.0	0.3	19.5	0.1	132
HAMMES AVE	LT	235+63	85	8.0	7.0	0.2	19.5	0.1	85
HAMMES AVE & I-57 SB RAMP		23562.88/236+50	233	20.0	19.0	0.5	85.6	0.1	233
I-57 SB EXIT RAMP	LT	236+50	852	72.0	69.0	1.8	35	0.3	852
I-57 SB ENTRANCE RAMP	LT	236+50	120	11.0	10.0	0.3	11.2	0.1	120
I-57 NB RAMP	RT	242+15	767	65.0	62.0	1.6	22.3	0.3	767
EASTRIDGE DR	RT	245+41	260	22.0	21.0	0.6	0	0.1	260
FRONTAGE RD	LT	245+60	271	23.0	22.0	0.6	0	0.1	271
EASTGATE PARKWAY	LT	263+36	855	72.0	69.0	1.8	27.8	0.3	855
FRONTAGE RD	RT	263+36	791	67.0	64.0	1.6	0	0.3	791
SPEAR RD	LT	277+62	407	35.0	33.0	0.9	30.6	0.2	407
SOUTH FRONTAGE RD	RT	277+62	312	27.0	25.0	0.7	33.4	0.1	312
LOWE RD	RT	58+80	232	20.0	19.0	0.5	21.7	0.1	232
FOG COAT					612.0				
TOTALS			12,232	1,054	1,612	27	1,075	6	12232

RAISED REFLECTIVE PAVEMENT MARKERS	QUANTITY
CRYSTAL ONE-WAY	902
AMBER ONE-WAY	178
AMBER TWO-WAY	468
TOTAL	1548

CLASS D PATCHES, 12 INCH				
LOG MILES	LANE	TYPE II	TYPE III	TYPE IV
		SQ YD	SQ YD	SQ YD
<b>WESTBOUND</b>				
0.00 = 5TH AVENUE				
0.35	DL		16	
0.55	DL			27
0.55	PL			27
0.70	DL	8		
0.80	DL	8		
0.90	DL	8		
0.95	DL	8		
1.00	DL	8		
1.10	DL	8		
1.20	DL			27
1.40	DL		16	
2.70	PL	8		
2.75	PL	8		
2.97	PL	8		
3.00	PL	8		
3.02	PL	8		
3.02	DL	8		
SUBTOTAL		96	32	81
<b>EASTBOUND</b>				
0.00 = 5TH AVENUE				
0.35	DL	8		
0.40	DL	8		
0.40	PL	8		
0.42	DL			27
0.42	PL			27
0.45	PL	8		
0.50	DL	8		
0.50	PL	8		
1.20	DL	8		
1.30	DL	8		
1.30	PL	8		
1.50	DL	8		
1.50	PL	8		
1.55	DL	8		
1.55	PL	8		
1.60	PL	8		
2.40	PL	8		
2.45	PL	8		
2.50	DL	8		
2.50	PL	8		
2.60	DL			27
2.70	PL	8		
2.85	PL	8		
2.90	PL	8		
2.95	DL	8		
SUBTOTAL		176	0	81
TOTAL		272	32	162

STRIP REFLECTIVE CRACK CONTROL	
LOCATION	FOOT
STATION TO STATION	
138+00 - 152+00 (EB & WB)	2800
(CONCRETE OMISSION)	
159+00 - 221+01 (EB & WB)	12402
(RAILROAD OMISSION)	
221+17 - 249+19.06 (EB & WB)	5606
(STATION EQ. 249+19.03=3+83.36)	
TOTALS	20808



CONCRETE SCHEDULE (CONTINUED)													
LOCATION	QUADRANT	SUGGESTED METHOD	CC&G REM	CC&G TYPE, B-6.18	SIDEWALK REM	PCC SIDEWALK 4IN.	PCC SIDEWALK 8IN.	DETECT WARN	MEDIAN REM	SODDING SALT TOLERANT	NITROGEN	PHOSPHORUS	POTASSIUM
			FOOT	FOOT	SQ FT	SQ FT	SQ FT	SQ FT	SQ FT	SQ FT	SQ YD	POUND	POUND
ST. JOSEPH AVENUE	NW	424011	20.0	20.0	100.0	100.0		20.0		0.0	0.0	0.0	0.0
	NE	424011	20.0	20.0	118.8	118.8		20.0		0.0	0.0	0.0	0.0
HAMMES AVENUE	NW	424011	23.0	23.0	92.0	92.0		16.0		0.0	0.0	0.0	0.0
	NE	424001	0.0	0.0	35.0	35.0		10.0		0.0	0.0	0.0	0.0
SB EXIT/ENTRANCE RAMP I-57	NW	424001	0.0	0.0	35.0	35.0		10.0		2.0	0.0	0.0	0.0
SB EXIT/ENTRANCE RAMP I-57	NE	424011	40.0	40.0	200.0		200.0	20.0		9.0	0.1	0.1	0.1
NB EXIT/ENTRANCE RAMP I-57	SW	424001	0.0	0.0		36.0		12.0		3.0	0.0	0.0	0.0
NB EXIT/ENTRANCE RAMP I-57	CENTER					30.0		10.0	30.0				
NB EXIT/ENTRANCE RAMP I-57	SE	424001	0.0	0.0	40.0	40.0		10.0		3.0	0.0	0.0	0.0
FRONTAGE ROAD	NW	424001	7.0	7.0	20.0	20.0		8.0		3.0	0.0	0.0	0.0
EASTRIDGE DRIVE	SW	424011	27.0	27.0	145.0	145.0		24.0		3.0	0.0	0.0	0.0
SUBTOTAL			137.00	137.00	821.75	651.75	200.00	160.00	30.00	23.00	0.29	0.29	0.29
TOTALS			1352.0	1352.0	10344.0	10149.0	200.0	1733.0	30.0	266.0	4.0	4.0	4.0

STATION	PAVEMENT MARKING												RAISED REFLECT MARK EACH
	70300100 SHORT TERM PAVT MARK 4 IN FOOT	78003100 PREF PLASTIC PAVT MRK TYPE B L&S SQ FT	78000200 THERMO PLASTIC MRK 4 IN FOOT	78004230 PREF PLASTIC PAVT MRK INLAID 6 IN FOOT	78000500 THERMO PLASTIC MRK 8 IN FOOT	78000600 THERMO PLASTIC MRK 12 IN FOOT	78003180 PREF PLASTIC PAVT MRK TYPE B 24 IN FOOT	X7800610 URETHANE PAVT MRK 4 IN FOOT	X7800640 URETHANE PAVT MRK 8 IN FOOT	X7800650 URETHANE PAVT MRK 12 IN FOOT	X7830074 GROOVE RECESSED PAVT MRK 7 IN FOOT	X7830076 GROOVE RECESSED PAVT MRK 9 IN FOOT	
STA. 138+00 - 139+14	63	15.6	166	443	46	428	60					46	2
STA. 139+14 - 142+25	434	93.6	774	156	380	0	83					380	42
STA. 142+25 - 146+11	354	62.4	750	575	277	414	110					277	37
STA. 146+11 - 150+03	354	62.4	862	700	180	552	135					180	36
STA. 150+03 - 152+00	292	114.4	434	677	173	625	93					173	15
STA. 152+00 - 159+00	0	0.0	0	634	0	0	14	1713	118	342	634	118	31
STA. 159+00 - 164+11	510	93.6	1137	741	306	524	120					306	51
STA. 164+11 - 167+85	402	0.0	1400	405	0	420	29					0	30
STA. 167+85 - 171+84	371	62.4	794	730	272	520	132					272	41
STA. 171+84 - 175+81	411	46.8	1114	687	170	608	77					170	33
STA. 175+81 - 179+66	343	62.4	782	723	163	286	68					163	39
STA. 179+62 - 183+58	340	62.4	1053	712	0	270	63					0	32
STA. 183+58 - 187+42	339	62.4	990	568	0	130	28					0	32
STA. 187+46 - 195+27	695	124.8	1828	984	0	136	42					0	68
STA. 195+27 - 199+67	400	62.4	1399	385	118	0	24					118	38
STA.199+67 - 210+75	912	347.6	3187	1550	51	484	78					51	95
STA. 210+75 - 221+01	841	232.8	3297	1342	289	274	191					289	78
STA. 221+17 - 234+50	1555	357.6	6034	1403	504	406	197					504	133
STA. 234+50 - 249+19.06	1543	421.2	3687	1142	925	572	340					925	128
SO 249+19.06=3+83.36													
STA.3+83.36 - 18+50	1392	62.4	3372	684	390	132	155					390	106
STA.18+50 - 65+00	3826	31.2	19143	2303	906	0	96					906	481
NOTE: LOCATION STATION 152+00 - 159+00 HAS 31 EACH RAISED REFLECTOR MARKERS SET IN CONCRETE PAVEMENT AND NEEDS TO BE REMOVED AND REPLACED IN ACCORDANCE WITH SECTION 783 OF THE STANDARD SPECIFICATIONS FOR ROAD AND BRIDGE CONSTRUCTION BOOK.													
TOTALS	15,377	2378.4	52,203	17,544	5,150	6,781	2,135	1,713	118	342	634	5,268	1,548

ELECTRICAL SCHEDULE OF QUANTITIES (5TH AVE.)		
DESCRIPTION	UNIT	QUANTITY
INDUCTIVE LOOP DETECTOR - SEE NOTE 1	EACH	3
DETECTOR LOOP, TYPE 1	FOOT	629
LOOP DETECTOR TESTING	EACH	1
MODIFY EXISTING CONTROLER CABINET	EACH	1

ELECTRICAL SCHEDULE OF QUANTITIES (4TH AVE.)		
DESCRIPTION	UNIT	QUANTITY
INDUCTIVE LOOP DETECTOR - SEE NOTE 2	EACH	10
DETECTOR LOOP, TYPE 1	FOOT	1320
LOOP DETECTOR TESTING	EACH	1
MODIFY EXISTING CONTROLER CABINET	EACH	1

ELECTRICAL SCHEDULE OF QUANTITIES (3RD AVE.)		
DESCRIPTION	UNIT	QUANTITY
INDUCTIVE LOOP DETECTOR - SEE NOTE 1	EACH	2
DETECTOR LOOP, TYPE 1	FOOT	776
LOOP DETECTOR TESTING	EACH	1
MODIFY EXISTING CONTROLER CABINET	EACH	1

ELECTRICAL SCHEDULE OF QUANTITIES (WASHINGTON AVE.)		
DESCRIPTION	UNIT	QUANTITY
INDUCTIVE LOOP DETECTOR - SEE NOTE 1	EACH	7
DETECTOR LOOP, TYPE 1	FOOT	1491
LOOP DETECTOR TESTING	EACH	1
MODIFY EXISTING CONTROLER CABINET	EACH	1

ELECTRICAL SCHEDULE OF QUANTITIES (SCHUYLER AVE.)		
DESCRIPTION	UNIT	QUANTITY
INDUCTIVE LOOP DETECTOR - SEE NOTE 2	EACH	10
DETECTOR LOOP, TYPE 1	FOOT	1185
LOOP DETECTOR TESTING	EACH	1
MODIFY EXISTING CONTROLER CABINET	EACH	1

ELECTRICAL SCHEDULE OF QUANTITIES (INDIANA AVE.)		
DESCRIPTION	UNIT	QUANTITY
INDUCTIVE LOOP DETECTOR - SEE NOTE 1	EACH	1
DETECTOR LOOP, TYPE 1	FOOT	513
LOOP DETECTOR TESTING	EACH	1
MODIFY EXISTING CONTROLER CABINET	EACH	1

ELECTRICAL SCHEDULE OF QUANTITIES (HARRISON AVE.)		
DESCRIPTION	UNIT	QUANTITY
INDUCTIVE LOOP DETECTOR - SEE NOTE 2	EACH	2
DETECTOR LOOP, TYPE 1	FOOT	524
LOOP DETECTOR TESTING	EACH	1
MODIFY EXISTING CONTROLER CABINET	EACH	1

ELECTRICAL SCHEDULE OF QUANTITIES (GREENWOOD AVE.)		
DESCRIPTION	UNIT	QUANTITY
INDUCTIVE LOOP DETECTOR - SEE NOTE 1	EACH	3
DETECTOR LOOP, TYPE 1	FOOT	1005
LOOP DETECTOR TESTING	EACH	1
MODIFY EXISTING CONTROLER CABINET	EACH	1

NOTE 1: INDUCTIVE LOOP DETECTORS SHALL BE OF DUAL CONTROL RACK TYPE.  
NOTE 2: INDUCTIVE LOOP DETECTORS SHALL BE OF SHELF TYPE.

ELECTRICAL SCHEDULE OF QUANTITIES (HOBBIE AVE.)		
DESCRIPTION	UNIT	QUANTITY
INDUCTIVE LOOP DETECTOR - SEE NOTE 1	EACH	5
DETECTOR LOOP, TYPE 1	FOOT	734
LOOP DETECTOR TESTING	EACH	1
MODIFY EXISTING CONTROLER CABINET	EACH	1

ELECTRICAL SCHEDULE OF QUANTITIES (NELSON AVE.)		
DESCRIPTION	UNIT	QUANTITY
INDUCTIVE LOOP DETECTOR - SEE NOTE 2	EACH	13
DETECTOR LOOP, TYPE 1	FOOT	797
LOOP DETECTOR TESTING	EACH	1
MODIFY EXISTING CONTROLER CABINET	EACH	1

ELECTRICAL SCHEDULE OF QUANTITIES (FAIRMONT AVE.)		
DESCRIPTION	UNIT	QUANTITY
INDUCTIVE LOOP DETECTOR - SEE NOTE 2	EACH	11
DETECTOR LOOP, TYPE 1	FOOT	1297
LOOP DETECTOR TESTING	EACH	1
MODIFY EXISTING CONTROLER CABINET	EACH	1

ELECTRICAL SCHEDULE OF QUANTITIES (NORTH BOUND RAMP)		
DESCRIPTION	UNIT	QUANTITY
INDUCTIVE LOOP DETECTOR	EACH	0
DETECTOR LOOP, TYPE 1	FOOT	0
LOOP DETECTOR TESTING	EACH	0
MODIFY EXISTING CONTROLER CABINET	EACH	1

ELECTRICAL SCHEDULE OF QUANTITIES (SOUTH BOUND RAMP)		
DESCRIPTION	UNIT	QUANTITY
INDUCTIVE LOOP DETECTOR - SEE NOTE 1	EACH	1
DETECTOR LOOP, TYPE 1	FOOT	100
LOOP DETECTOR TESTING	EACH	0
MODIFY EXISTING CONTROLER CABINET	EACH	1

ELECTRICAL SCHEDULE OF QUANTITIES (EASTRIDGE DRIVE)		
DESCRIPTION	UNIT	QUANTITY
INDUCTIVE LOOP DETECTOR	EACH	0
DETECTOR LOOP, TYPE 1	FOOT	0
LOOP DETECTOR TESTING	EACH	0
MODIFY EXISTING CONTROLER CABINET	EACH	1

ELECTRICAL SCHEDULE OF QUANTITIES (EASTGATE PARKWAY)		
DESCRIPTION	UNIT	QUANTITY
INDUCTIVE LOOP DETECTOR - SEE NOTE 2	EACH	14
DETECTOR LOOP, TYPE 1	FOOT	1370
LOOP DETECTOR TESTING	EACH	1
MODIFY EXISTING CONTROLER CABINET	EACH	1

ELECTRICAL SCHEDULE OF QUANTITIES (LOWE ROAD)		
DESCRIPTION	UNIT	QUANTITY
INDUCTIVE LOOP DETECTOR - SEE NOTE 1	EACH	5
DETECTOR LOOP, TYPE 1	FOOT	914
LOOP DETECTOR TESTING	EACH	1
MODIFY EXISTING CONTROLER CABINET	EACH	1

TOTAL ELECTRICAL SCHEDULE OF QUANTITIES		
DESCRIPTION	UNIT	QUANTITY
INDUCTIVE LOOP DETECTOR	EACH	87
DETECTOR LOOP, TYPE 1	FOOT	12655
LOOP DETECTOR TESTING	EACH	13
MODIFY EXISTING CONTROLER CABINET	EACH	16



CHANGES OF LOOP DETECTORS (WASHINGTON AVE.)		
LOCATION	EXISTING	PROPOSED
WESTBOUND TURN LANE	2 @ 6' X 20'	3 @ 6' X 15'

CHANGES OF LOOP DETECTORS (HOBBIE AVE.)		
LOCATION	EXISTING	PROPOSED
EASTBOUND TURN LANE	2 @ 6' X 20'	3 @ 6' X 15'

CHANGES OF LOOP DETECTORS (FAIRMONT AVE.)		
LOCATION	EXISTING	PROPOSED
WESTBOUND TURN LANE	3 @ 6' X 15'	3 @ 6' X 20'
EASTBOUND TURN LANE	3 @ 6' X 15'	3 @ 6' X 20'
COMMERCIAL ENT. NORTHBOUND	2 @ 6' X 15'	2 @ 6' X 20'

CHANGES OF LOOP DETECTORS (EASTGATE PKWY.)		
LOCATION	EXISTING	PROPOSED
WESTBOUND TURN LANE	2 @ 6' X 20'	3 @ 6' X 20'
EASTBOUND TURN LANE	2 @ 6' X 20'	3 @ 6' X 20'
FRONTAGE ROAD	4 @ 6' X 15'	4 @ 6' X 20'

GENERAL NOTES

1. PLACE DETECTOR LOOPS IN BINDER OR MILLED SURFACE.
2. DETECTOR LOOPS SHALL HAVE FOUR TURNS.  
ADVANCED WARNINGS SHALL HAVE SIX TURNS.
3. SAW CUT EXISTING DETECTOR LOOP TO BE ABANDONED.
4. THE DEPARTMENT OF TRANSPORTATION (815-434-8506) SHALL BE NOTIFIED AT LEAST 72 HOURS PRIOR TO THE LAYOUT OF THE DETECTOR LOOPS.
5. QUANTITIES OF DETECTOR LOOP, TYPE 1 ARE BASED ON REPLACING ALL THE LOOPS IN THE MILLED PAVEMENT AT EACH INTERSECTION.  
"FOR INFORMATION ONLY" PLANS HAVE BEEN INCLUDED TO REPLACE THE LOOPS AT EACH INTERSECTION.
6. QUANTITIES FOR DETECTOR LOOP TESTING ARE INCLUDED TO TEST LOOPS ON SIDE ROADS WHERE PAVEMENT HAS NOT BEEN MILLED.
7. FOUR INTERSECTIONS WILL HAVE LOOP LAYOUTS MODIFIED FROM WHAT THE "FOR INFORMATION ONLY" PLANS SHOW, THIS WORK IS DETAILED IN A SCHEDULE ON THIS PLAN SHEET.

ADJUSTMENT SCHEDULE					
LOCATION	MANHOLES TO BE ADJ	MANHOLES TO BE ADJ W/ NEW TY1 FRAME & LID	HANDHOLE TO BE ADJ	WATER VALVES TO BE ADJ	INLET TO BE ADJ.
	60255500 EACH	60255800 EACH	81400115 EACH	56109210 EACH	60260100 EACH
STA 138+00 - STA 142+56	4			9	6
STA 142+56 - STA 146+50	4	1		2	3
STA 146+50 - STA 150+41	6	1	1	2	6
STA 150+41 - STA 160+51	4			6	7
STA 160+51 - STA 164+25	2		4	4	2
STA 164+25 - STA 168+30	6	1	5	7	2
STA 168+30 - STA 172+20	1	2	4	3	3
STA 172+20 - STA 176+12	3		5		2
STA 176+12 - STA 180+03	1		4	4	3
STA 180+03 - STA 183+92	2		1	2	2
STA 183+92 - STA 187+83	3				2
STA 187+83 - STA 191+73	4	2		7	4
STA 191+73 - STA 195+63	4			4	2
STA 195+63 - STA 200+04	6			3	
STA 200+04 - STA 205+69	3	1		3	3
STA 205+69 - STA 211+00	2	3		1	3
STA 211+00 - STA 214+35	6	2		3	2
STA 214+35 - STA 219+47				3	1
STA 219+47 - STA 224+50	1			2	4
STA 224+50 - STA 228+30				5	1
STA 228+30 - STA 235+63	4	1			4
STA 235+63 - STA 242+15	5			1	8
STA 242+15 - STA 245+61	3			2	4
STA 245+61 - STA 18+00	4			5	14
STA 18+00 - STA 32+26	2				2
STA 32+26 - STA 66+50					
<b>TOTALS</b>	<b>80</b>	<b>15</b>	<b>24</b>	<b>78</b>	<b>90</b>



NOTES:

FOR LAYOUT OF DETECTOR LOOPS SEE DETECTOR LOOP INFORMATION SHEETS 34 - 49

EXACT LIMITS OF SIDEWALK AND CURB REMOVAL TO BE DETERMINED IN THE FIELD BY THE ENGINEER

ALL STOP BARS SHALL BE 4 FOOT IN BACK OF THE CROSSWALK - SEE DETAILS

FOR COLOR, TYPE AND SPACING OF RAISED REFLECTIVE PAVEMENT MARKING SEE STANDARD 781001

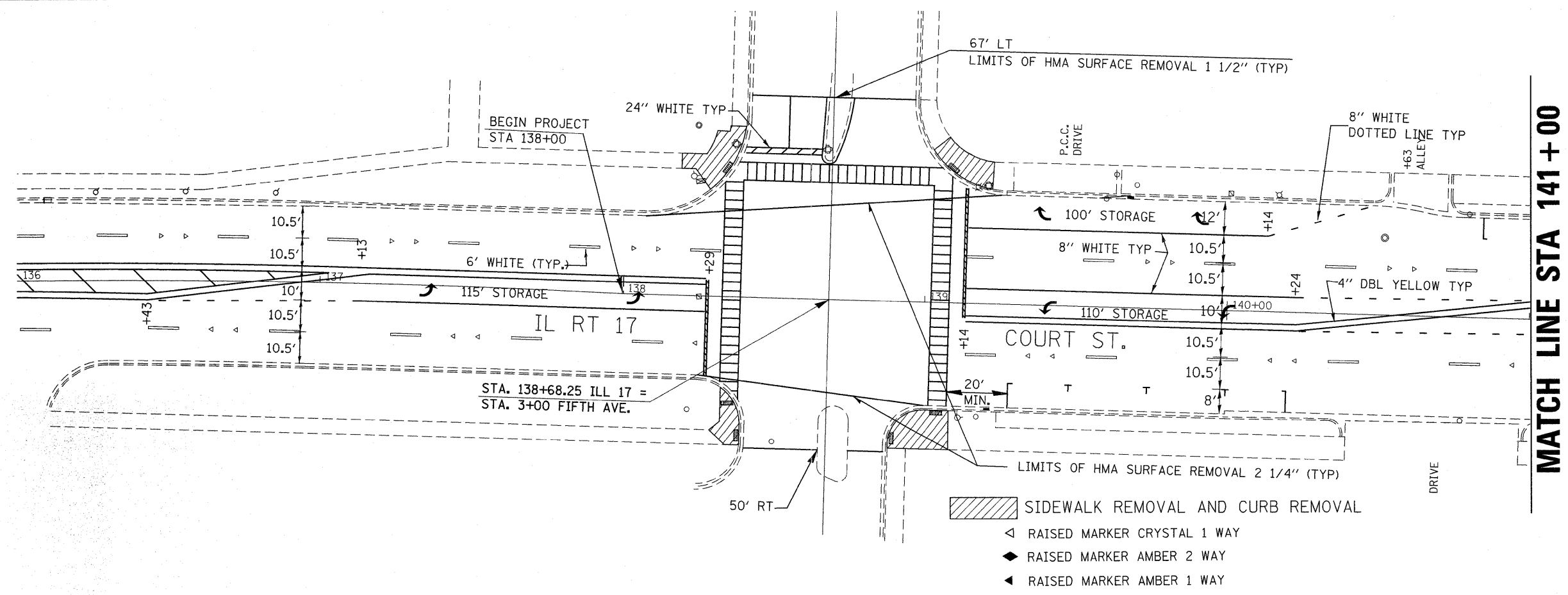

MATCH LINE STA 141+00

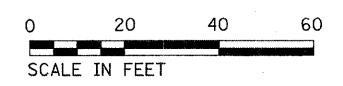

- SIDEWALK REMOVAL AND CURB REMOVAL
- RAISED MARKER CRYSTAL 1 WAY
- RAISED MARKER AMBER 2 WAY
- RAISED MARKER AMBER 1 WAY

FILE NAME =	USER NAME = leaf.jw	DESIGNED -	REVISED -	<b>STATE OF ILLINOIS DEPARTMENT OF TRANSPORTATION</b>	<b>PLAN SHEET</b>	F.A.P. RTE.	SECTION	COUNTY	TOTAL SHEETS	SHEET NO.	
ca\pwwork\pwwork\quigley\m1\00282391\ED066604-sht-plan.dgn	6604-sht-plan.dgn	DRAWN -	REVISED -			330	(1,1R-2)RS	KANKAKEE	54	17	
PLOT SCALE = 20.0000' / 1in.	CHECKED -	REVISED -	REVISED -			SCALE: 1"=20' SHEET OF SHEETS STA. TO STA.					
PLOT DATE = 12/20/2011	DATE -	REVISED -	REVISED -			ILLINOIS FED. AID PROJECT CONTRACT NO. 66477					

**MATCH LINE STA 141+00**

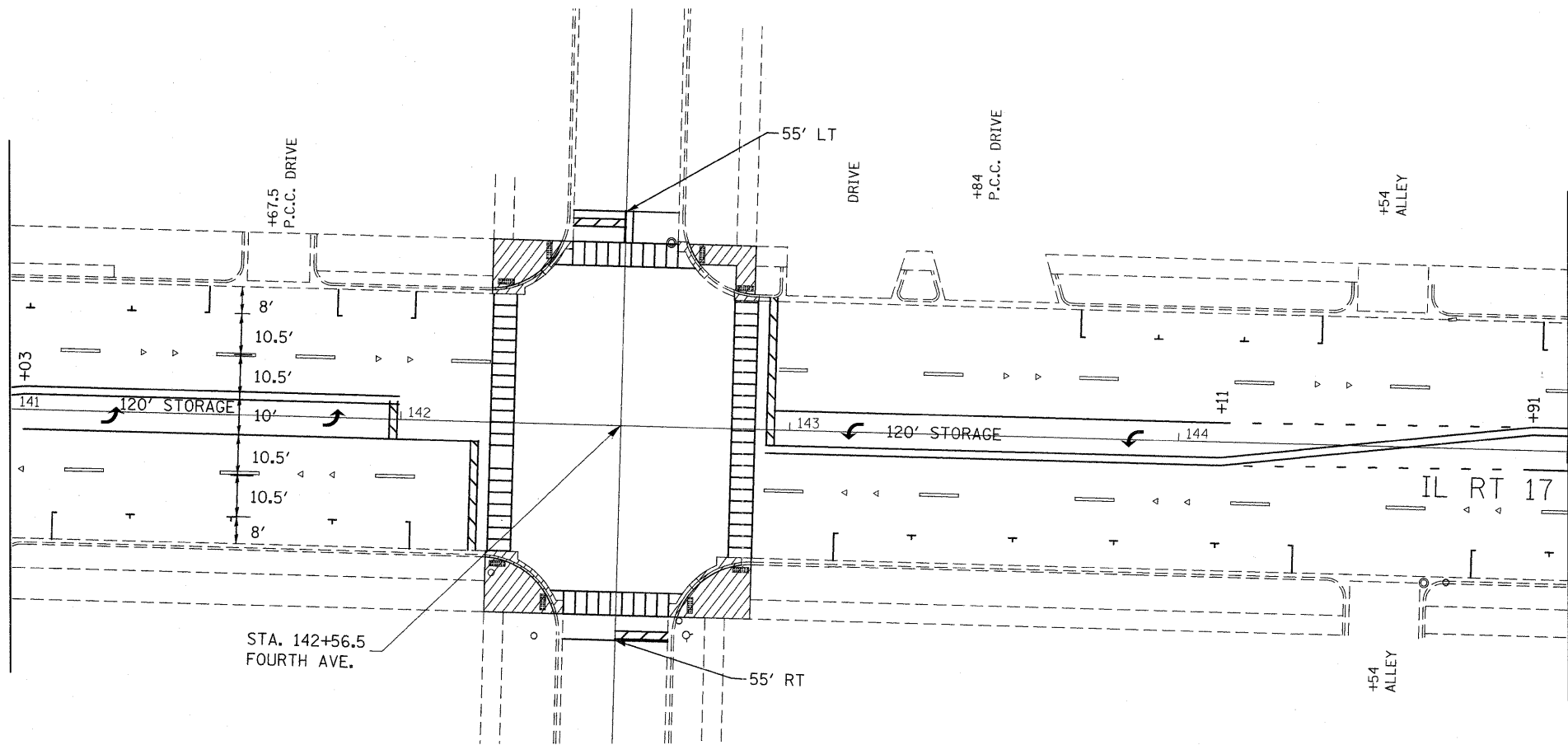

**MATCH LINE STA 145+00**

**MATCH LINE STA 145+00**

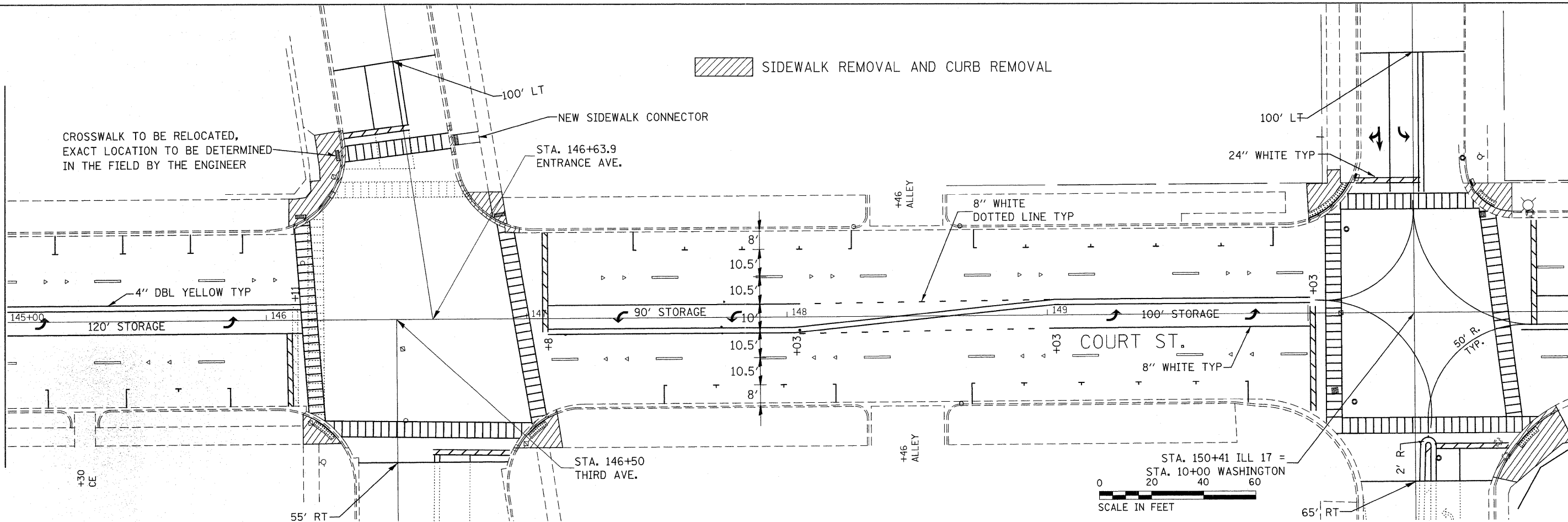

**MATCH LINE STA 151+00**

FILE NAME =  
c:\pw\_work\pwwork\qunglaym1\d0282391\ED06684-ah-t-plan.dgn

USER NAME = leafjw  
PLOT SCALE = 28,0000' / 1" / 1" / 1"  
PLOT DATE = 12/20/2011

DESIGNED -  
DRAWN -  
CHECKED -  
DATE -

REVISED -  
REVISED -  
REVISED -  
REVISED -

**STATE OF ILLINOIS  
DEPARTMENT OF TRANSPORTATION**

**PLAN SHEET**

SCALE: 1"=20' SHEET OF SHEETS STA. TO STA.

F.A.P. RTE.	SECTION	COUNTY	TOTAL SHEETS	SHEET NO.
330	(1,1R-2)RS	KANKAKEE	54	18
CONTRACT NO. 66477				
ILLINOIS FED. AID PROJECT				

MATCH LINE STA 151+00

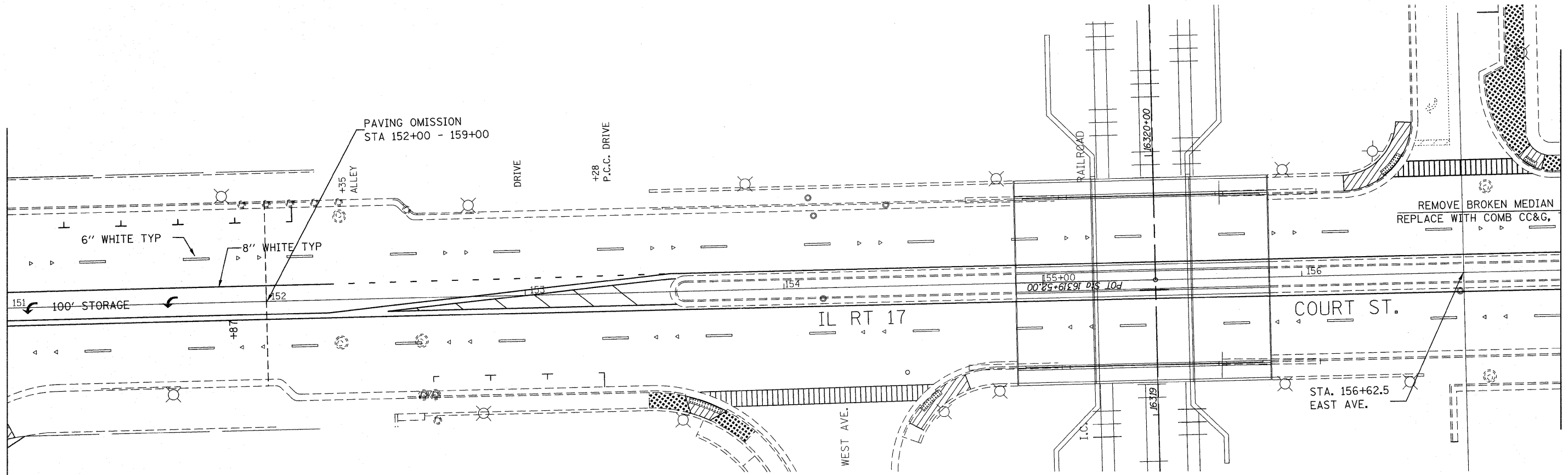

MATCH LINE STA 157+00

MATCH LINE STA 157+00

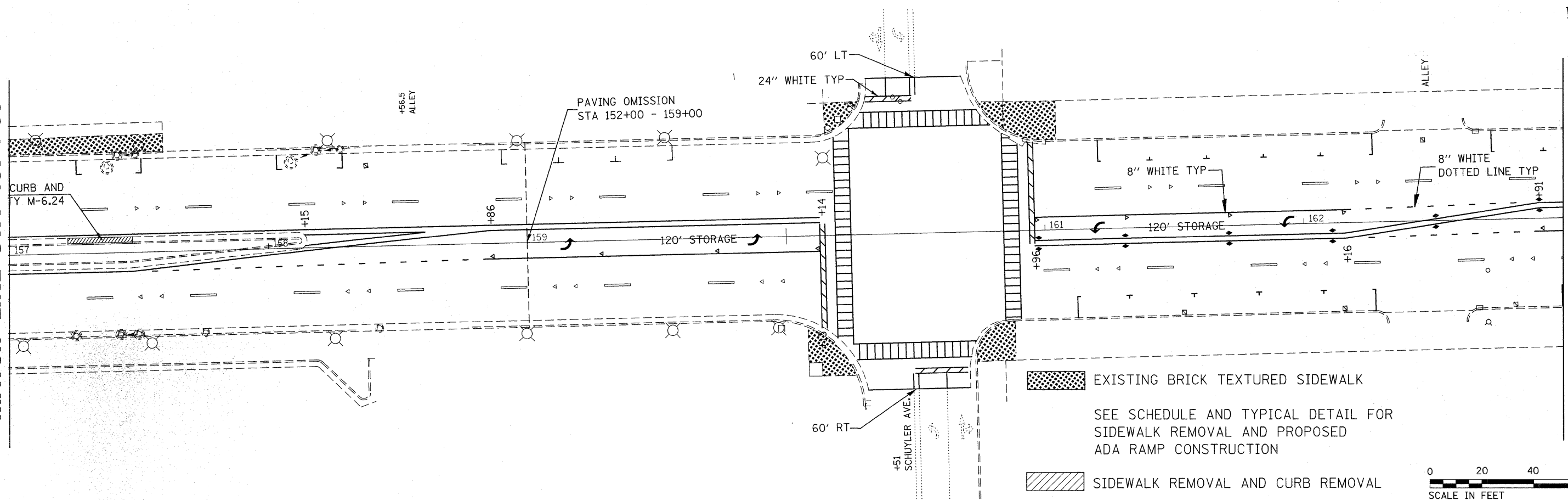

MATCH LINE STA 163+00

EXISTING BRICK TEXTURED SIDEWALK

SEE SCHEDULE AND TYPICAL DETAIL FOR SIDEWALK REMOVAL AND PROPOSED ADA RAMP CONSTRUCTION

SIDEWALK REMOVAL AND CURB REMOVAL

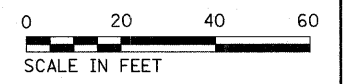

FILE NAME =	USER NAME = leaf.jw	DESIGNED -	REVISED -
cr:\pvc\work\pvc\dot\quagley\m\0202391\ED06604-shr-plan.dgn		DRAWN -	REVISED -
PLOT SCALE = 20.0000' / 1"		CHECKED -	REVISED -
PLOT DATE = 12/20/2011		DATE -	REVISED -

STATE OF ILLINOIS  
DEPARTMENT OF TRANSPORTATION

PLAN SHEET

SCALE: 1"=20' SHEET OF SHEETS STA. TO STA.

F.A.P. RTE.	SECTION	COUNTY	TOTAL SHEETS	SHEET NO.
330	(1,1R-2)RS	KANKAKEE	54	19
CONTRACT NO. 66477				
[ILLINOIS] FED. AID PROJECT				

MATCH LINE STA 163+00

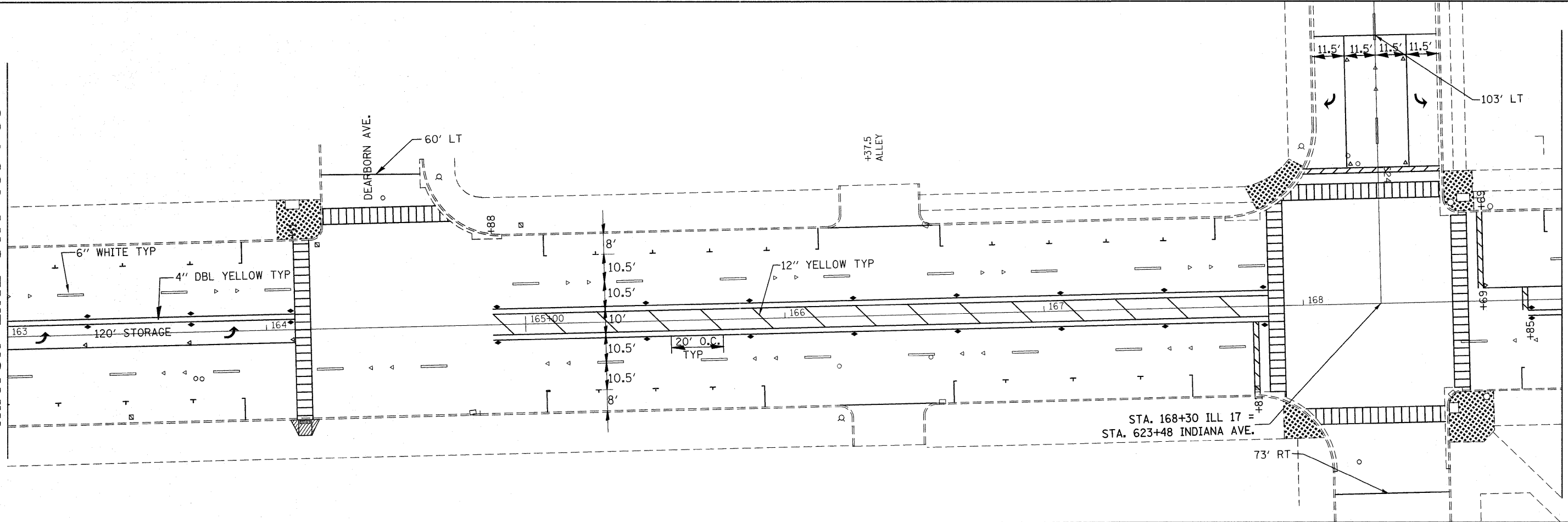

MATCH LINE STA 169+00

MATCH LINE STA 169+00

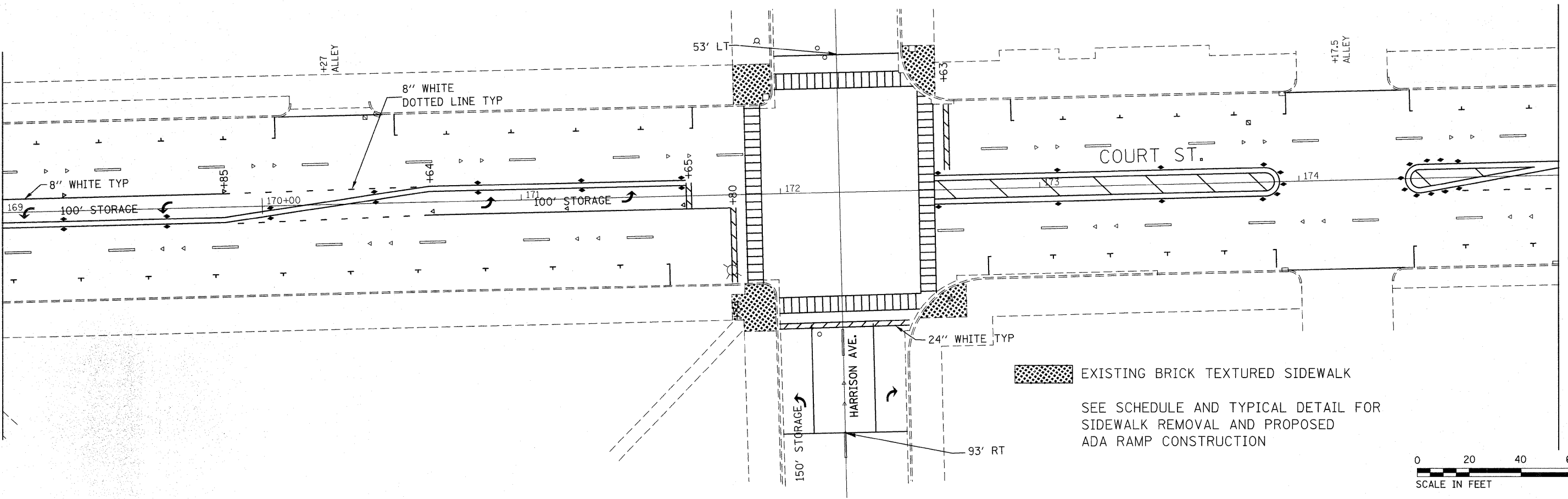

MATCH LINE STA 175+00

EXISTING BRICK TEXTURED SIDEWALK

SEE SCHEDULE AND TYPICAL DETAIL FOR SIDEWALK REMOVAL AND PROPOSED ADA RAMP CONSTRUCTION

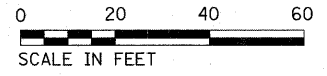

FILE NAME =	USER NAME = leaf.jw	DESIGNED -	REVISED -
ca:\pw\work\pwwdot\quigley\1\02022391\ED06604-ahs-plan.dgn		DRAWN -	REVISED -
PLT SCALE = 20.0000' / 1in.		CHECKED -	REVISED -
PLT DATE = 12/20/2011		DATE -	REVISED -

**STATE OF ILLINOIS  
DEPARTMENT OF TRANSPORTATION**

**PLAN SHEET**

SCALE: 1"=20' SHEET OF SHEETS STA. TO STA.

F.A.P. RTE.	SECTION	COUNTY	TOTAL SHEETS	SHEET NO.
330	(1,1R-2)RS	KANKAKEE	54	20
CONTRACT NO. 66477				

[ILLINOIS] FED. AID PROJECT

MATCH LINE STA 175+00

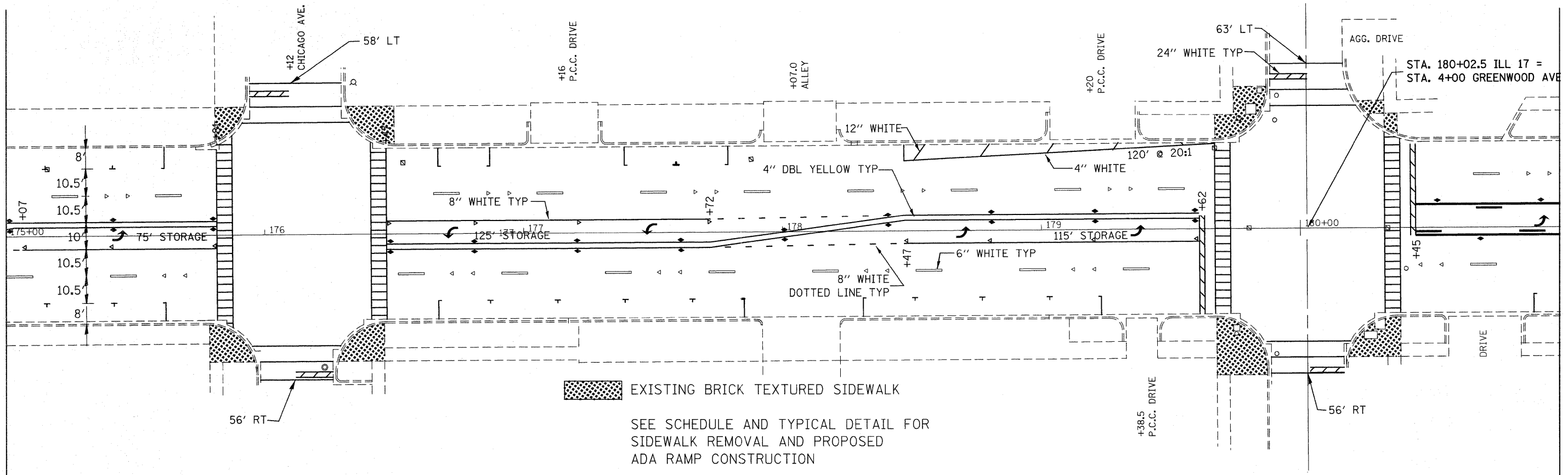

MATCH LINE STA 181+00

EXISTING BRICK TEXTURED SIDEWALK

SEE SCHEDULE AND TYPICAL DETAIL FOR SIDEWALK REMOVAL AND PROPOSED ADA RAMP CONSTRUCTION

MATCH LINE STA 181+00

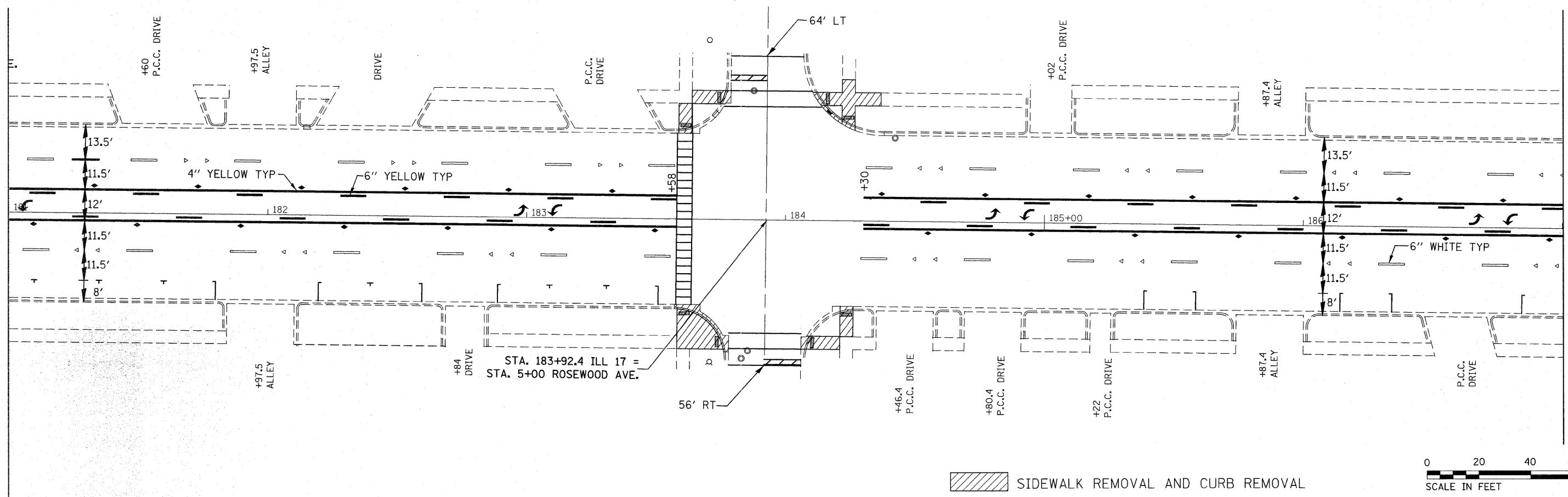

MATCH LINE STA 187+00

SIDEWALK REMOVAL AND CURB REMOVAL

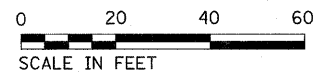

FILE NAME =	USER NAME = leef.jw
cd:\pw\work\pwwdot\quigley\m1\0282391\ED06604-ah-t-plan.dgn	
PLOT SCALE = 28.0000' / 1"	
PLOT DATE = 12/20/2011	

DESIGNED -	REVISED -
DRAWN -	REVISED -
CHECKED -	REVISED -
DATE -	REVISED -

STATE OF ILLINOIS  
DEPARTMENT OF TRANSPORTATION

PLAN SHEET

SCALE: 1"=20' SHEET OF SHEETS STA. TO STA.

F.A.P. RTE.	SECTION	COUNTY	TOTAL SHEETS	SHEET NO.
330	(1,1R-2)RS	KANKAKEE	54	21
CONTRACT NO. 66477				
ILLINOIS FED. AID PROJECT				

MATCH LINE STA 187+00

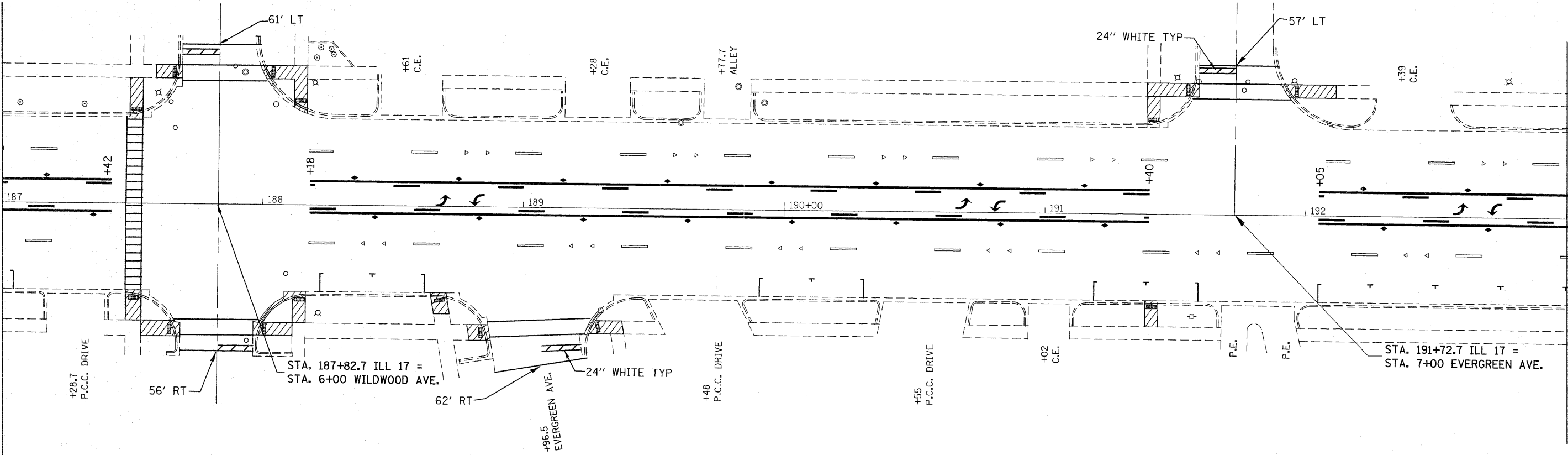

MATCH LINE STA 193+00

MATCH LINE STA 193+00

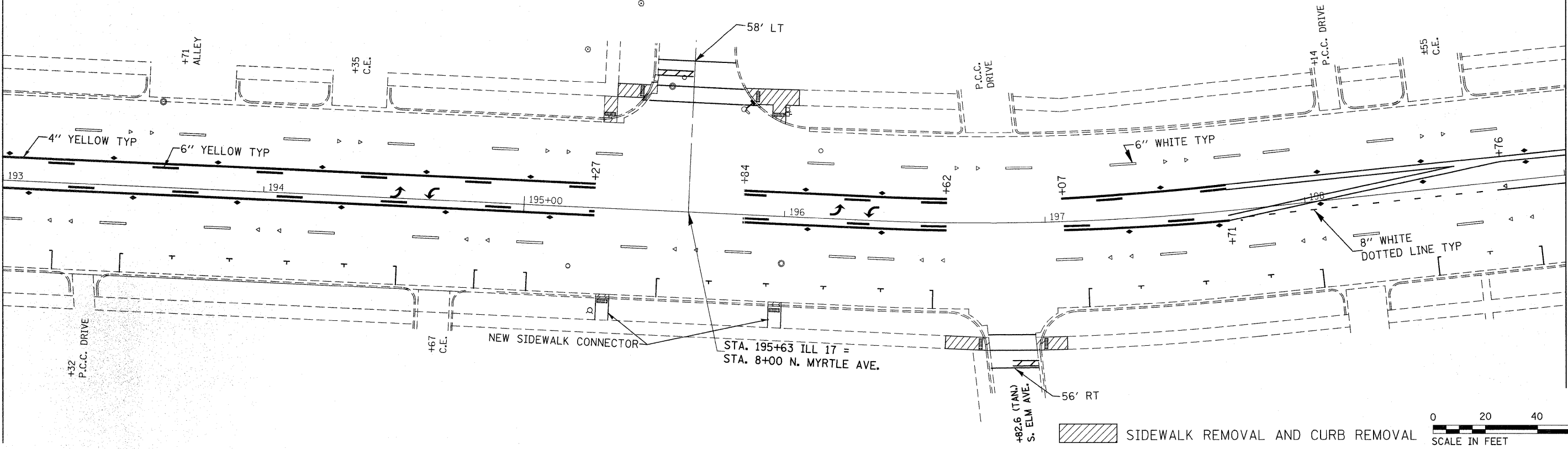

MATCH LINE STA 199+00

FILE NAME =  
 c:\pwwork\pwwork\qungleym\10282391\ED06604-shr-plan.dgn

USER NAME = leaf\_jw  
 DRAWN -  
 CHECKED -  
 PLOT SCALE = 20,0000' / 1"  
 PLOT DATE = 12/20/2011

DESIGNED -  
 DRAWN -  
 CHECKED -  
 DATE -

REVISED -  
 REVISED -  
 REVISED -  
 REVISED -

**STATE OF ILLINOIS  
 DEPARTMENT OF TRANSPORTATION**

SCALE: 1"=20' SHEET OF SHEETS STA. TO STA.

**PLAN SHEET**

F.A.P. RTE.	SECTION	COUNTY	TOTAL SHEETS	SHEET NO.
330	(1,1R-2)RS	KANKAKEE	54	22
CONTRACT NO. 66477				
ILLINOIS FED. AID PROJECT				



MATCH LINE STA 199+00

MATCH LINE STA 205+00

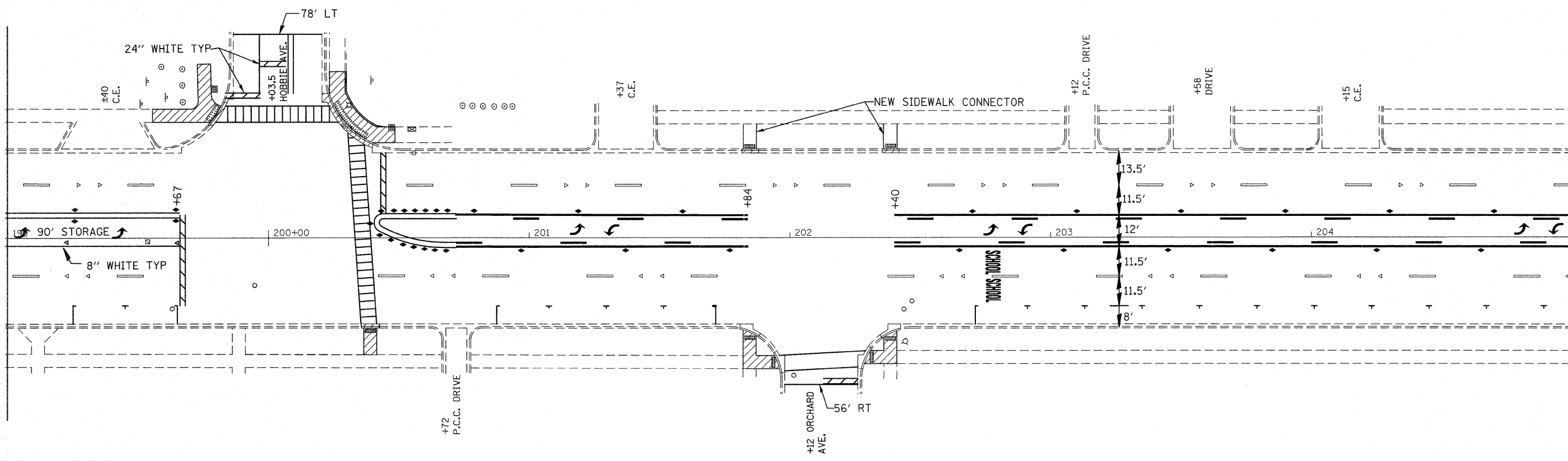

MATCH LINE STA 205+00

MATCH LINE STA 211+00

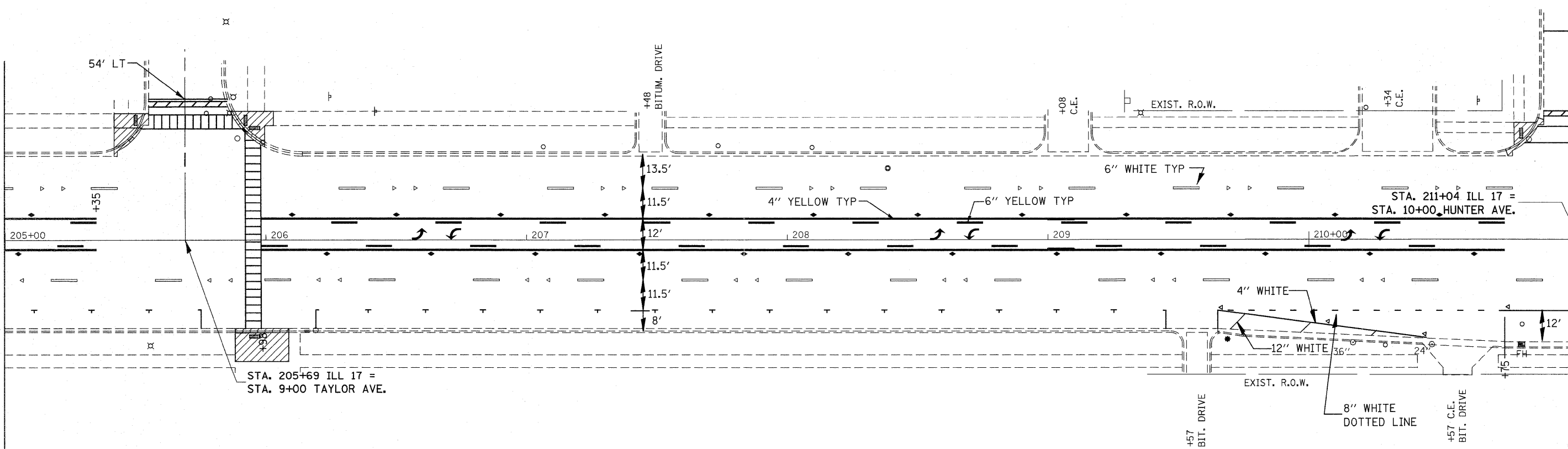

SIDEWALK REMOVAL AND CURB REMOVAL

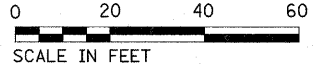

FILE NAME =	USER NAME = leaf_jw	DESIGNED -	REVISED -	<b>STATE OF ILLINOIS DEPARTMENT OF TRANSPORTATION</b>	<b>PLAN SHEET</b>	F.A.P. RTE.	SECTION	COUNTY	TOTAL SHEETS	SHEET NO.	
cd:\pwwork\pwwork\quigley\m1\02282391\ED026604-shr-plan.dgn	PLOT SCALE = 20,0000' / 1in.	DRAWN -	REVISED -			330	(1,1R-2)RS	KANKAKEE	54	23	
	PLOT DATE = 12/20/2011	CHECKED -	REVISED -			CONTRACT NO. 66477					
		DATE -	REVISED -			ILLINOIS FED. AID PROJECT					

MATCH LINE STA 211+00

MATCH LINE STA 217+00

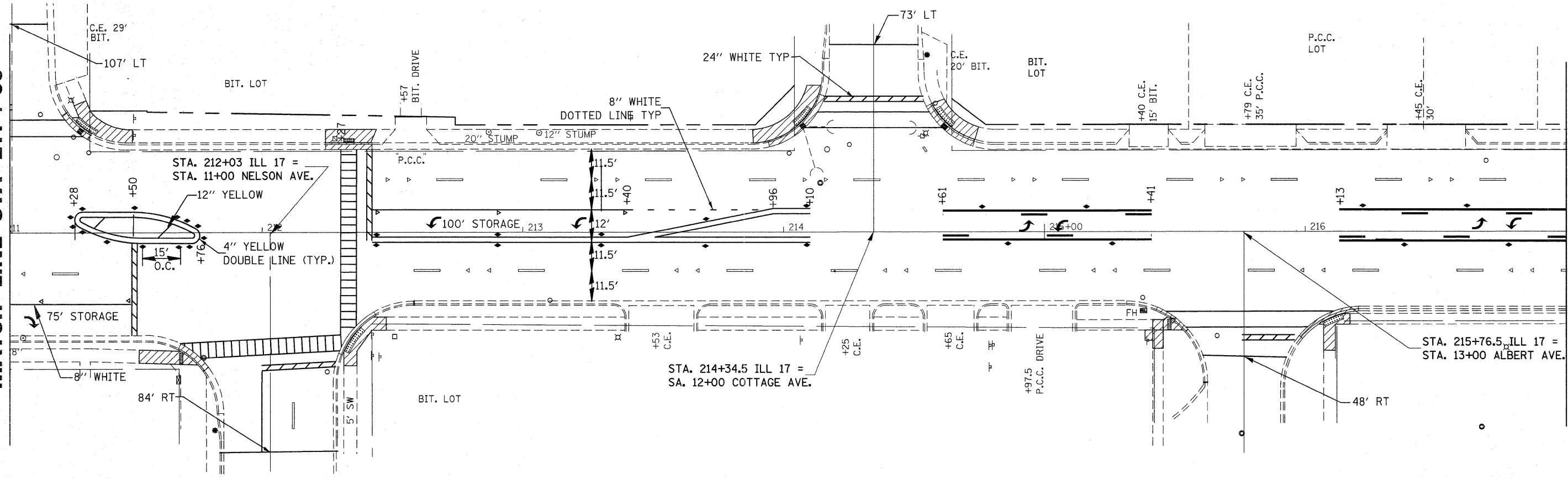

MATCH LINE STA 217+00

MATCH LINE STA 223+00

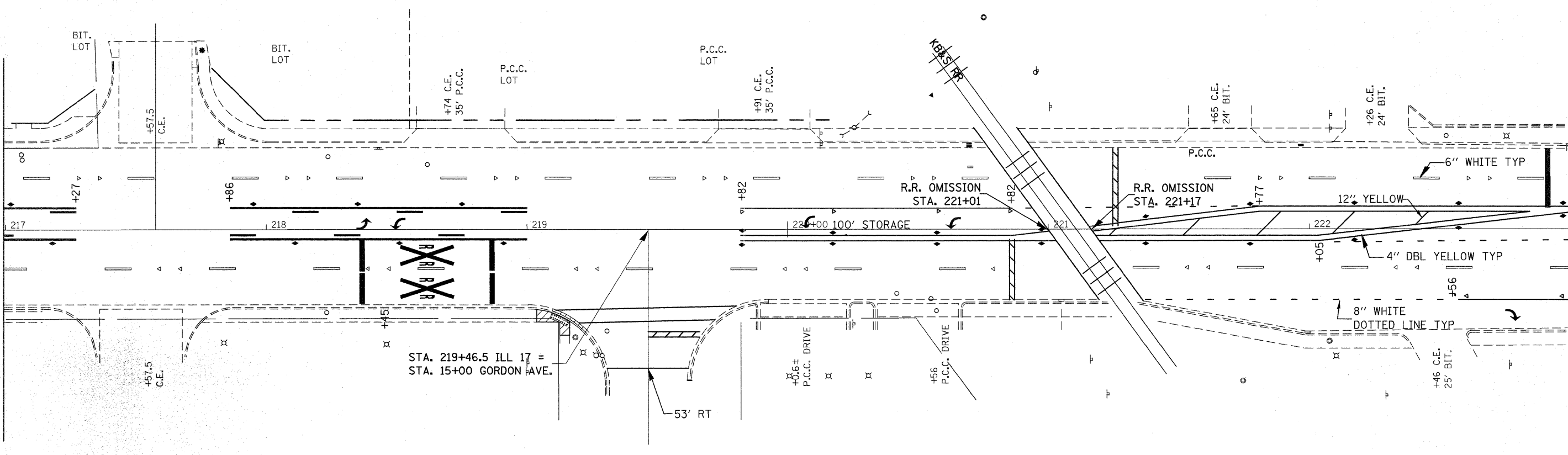

SIDEWALK REMOVAL AND CURB REMOVAL

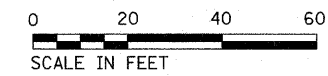

FILE NAME = c:\pwwork\psdot\qugl\ejm\1\202231\ED086804-sht-plan.dgn	USER NAME = leaf_jw	DESIGNED -	REVISED -	<b>STATE OF ILLINOIS DEPARTMENT OF TRANSPORTATION</b>	<b>PLAN SHEET</b>		F.A.P. RTE. = 330	SECTION = (1,1R-2)RS	COUNTY = KANKAKEE	TOTAL SHEETS = 54	SHEET NO. = 24
	PLLOT SCALE = 20.0000' / 1"	CHECKED -	REVISED -				SCALE: 1"=20'	SHEET OF SHEETS	STA. TO STA.	CONTRACT NO. 66477	
PLLOT DATE = 12/28/2011	DATE -	REVISED -	REVISED -								

MATCH LINE STA 223+00

MATCH LINE STA 229+00

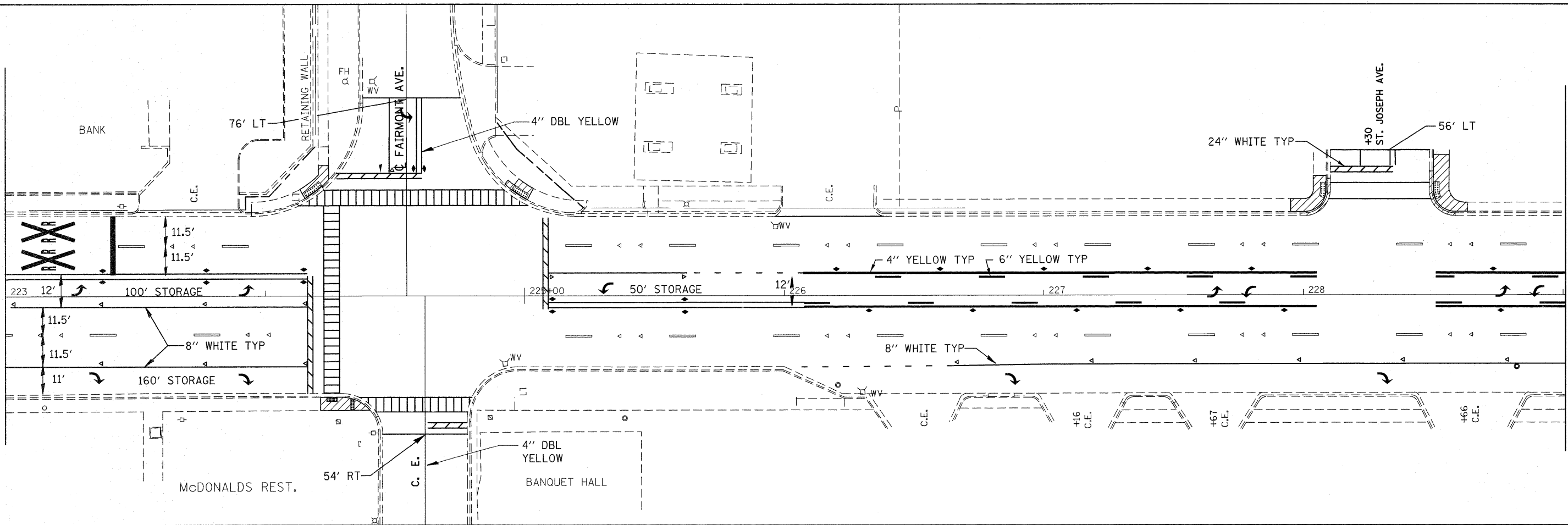

MATCH LINE STA 229+00

MATCH LINE STA 235+00

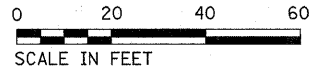
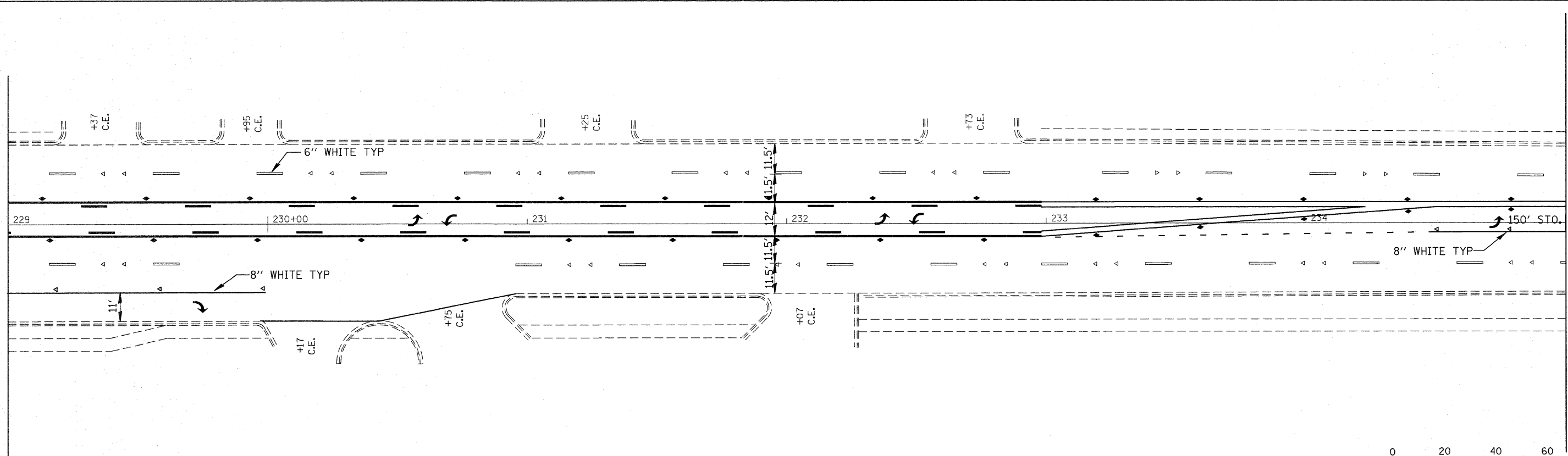

SIDEWALK REMOVAL AND CURB REMOVAL

FILE NAME =	USER NAME = leaf.jw	DESIGNED -	REVISED -
c:\pwwork\pwwork\qungleyml\d0282391\ED066604-sht-plan.dgn		DRAWN -	REVISED -
	PLOT SCALE = 28.0000' / 1" =	CHECKED -	REVISED -
	PLOT DATE = 12/28/2011	DATE -	REVISED -

STATE OF ILLINOIS  
DEPARTMENT OF TRANSPORTATION

PLAN SHEET

SCALE: 1"=20' SHEET OF SHEETS STA. TO STA.

F.A.P. RTE.	SECTION	COUNTY	TOTAL SHEETS	SHEET NO.
330	(1,1R-2)RS	KANKAKEE	54	25
CONTRACT NO. 66477			ILLINOIS FED. AID PROJECT	

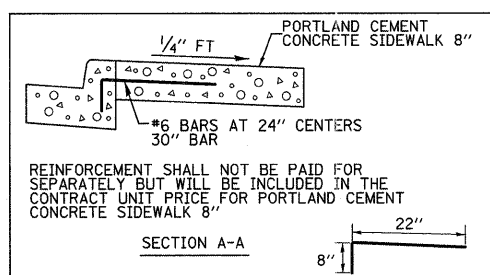
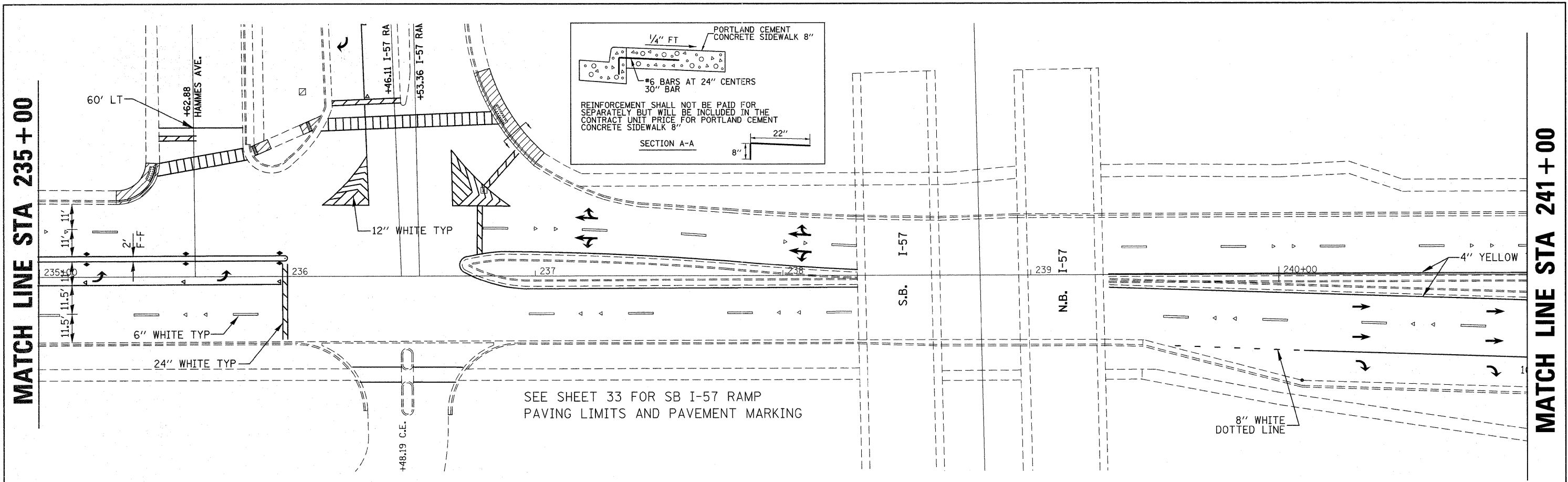

SEE SHEET 33 FOR SB I-57 RAMP  
PAVING LIMITS AND PAVEMENT MARKING

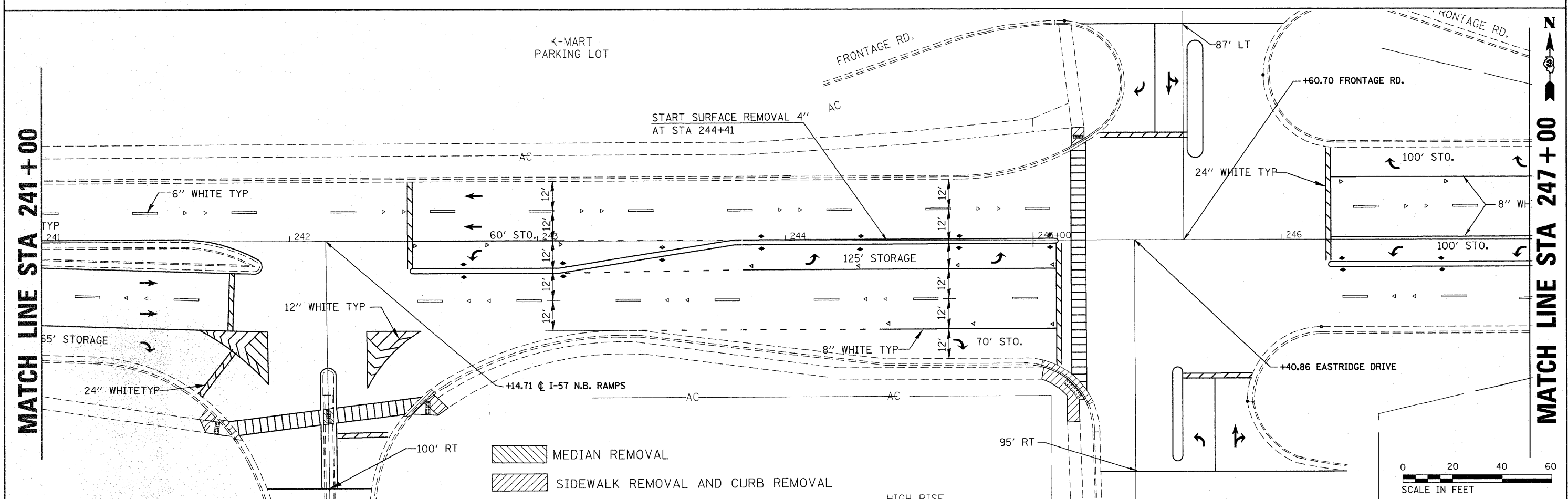

MEDIAN REMOVAL  
 SIDEWALK REMOVAL AND CURB REMOVAL

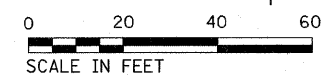

FILE NAME =	USER NAME = leaf.jw	DESIGNED -	REVISED -	<b>STATE OF ILLINOIS DEPARTMENT OF TRANSPORTATION</b>	<b>PLAN SHEET</b>	F.A.P. RTE.	SECTION	COUNTY	TOTAL SHEETS	SHEET NO.	
ca:\pwwork\pwwork\quagley\m\140282391\ED06604-sht-plan.dgn	PLOT SCALE = 20.0000' / 1" =	DRAWN -	REVISED -			330	(1,1R-2)RS	KANKAKEE	54	26	
	PLOT DATE = 12/20/2011	CHECKED -	REVISED -			SCALE: 1"=20' SHEET OF SHEETS STA. TO STA.					
		DATE -	REVISED -			CONTRACT NO. 66477					

ILLINOIS FED. AID PROJECT

MATCH LINE STA 247+00

MATCH LINE STA 7+50

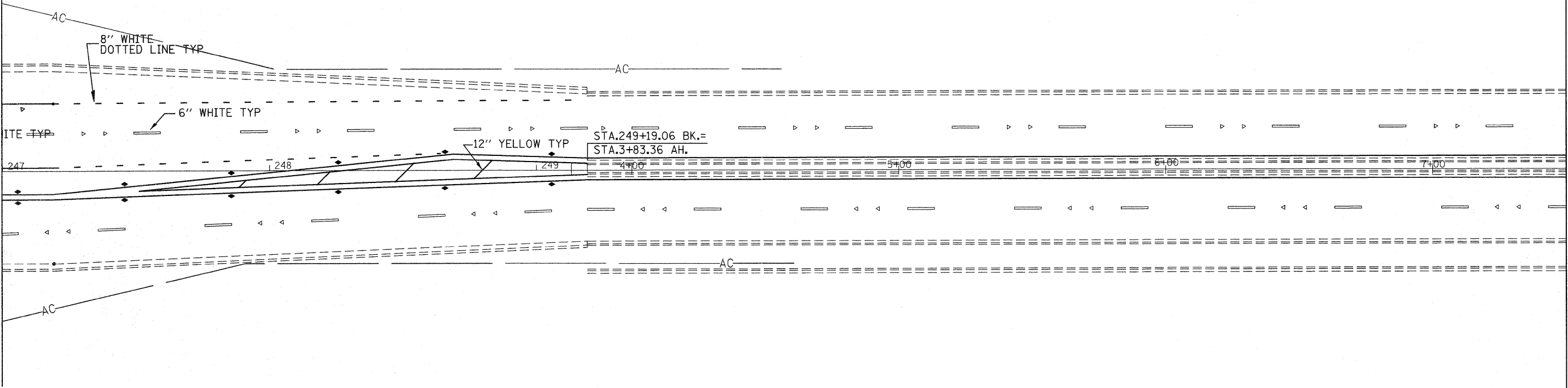

MATCH LINE STA 7+50

MATCH LINE STA 13+50

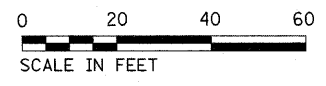
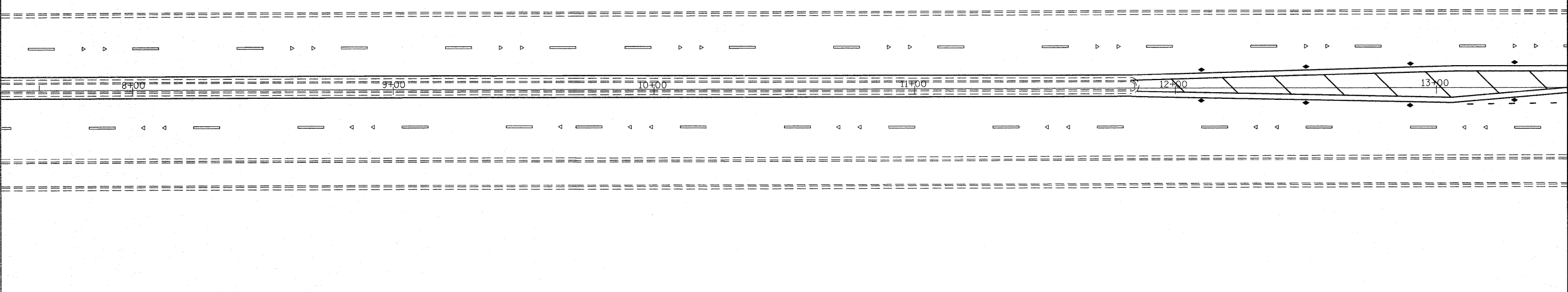

FILE NAME =	USER NAME = leafjw	DESIGNED -	REVISED -
ct:\pv_work\pv\dot\q\q\laym1\d0282391\ED06684-sh-t-plan.dgn		DRAWN -	REVISED -
	PLOT SCALE = 20.0000' / 1in.	CHECKED -	REVISED -
	PLOT DATE = 12/20/2011	DATE -	REVISED -

**STATE OF ILLINOIS  
DEPARTMENT OF TRANSPORTATION**

**PLAN SHEET**

SCALE: 1"=20' SHEET OF SHEETS STA. TO STA.

F.A.P. RTE.	SECTION	COUNTY	TOTAL SHEETS	SHEET NO.
330	(1,1R-2)RS	KANKAKEE	54	27
CONTRACT NO. 66477				
[ILLINOIS] FED. AID PROJECT				

MATCH LINE STA 13+50

MATCH LINE STA 19+50

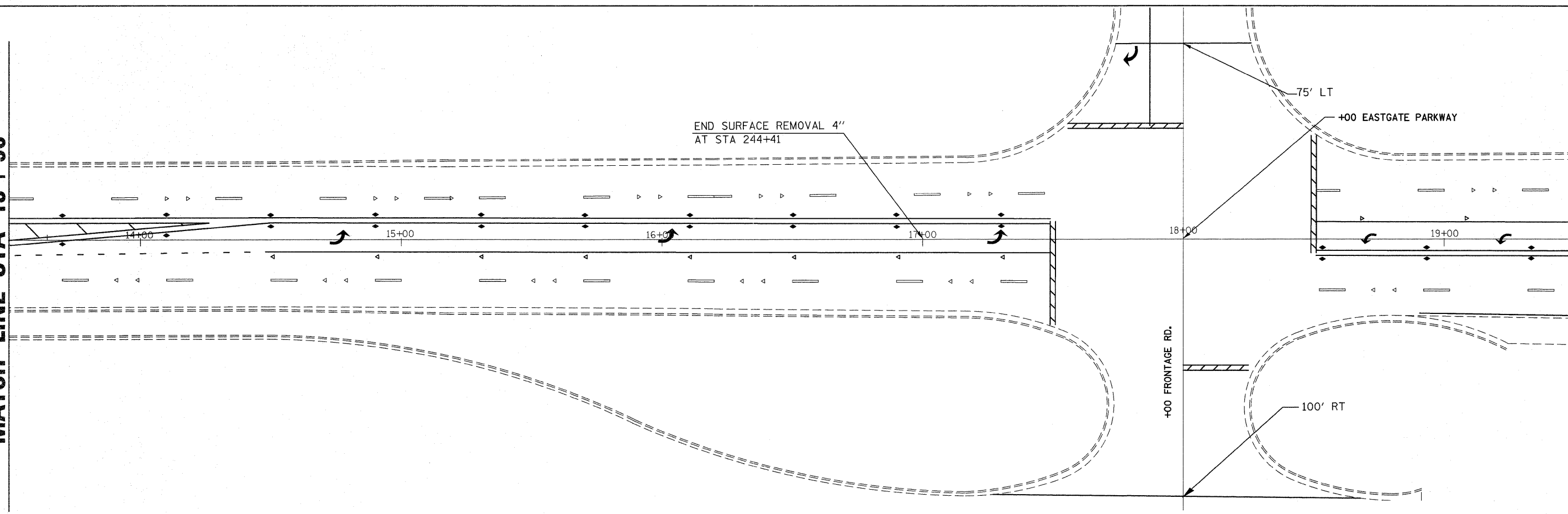

MATCH LINE STA 19+50

MATCH LINE STA 25+50

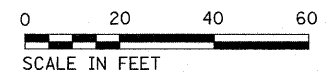
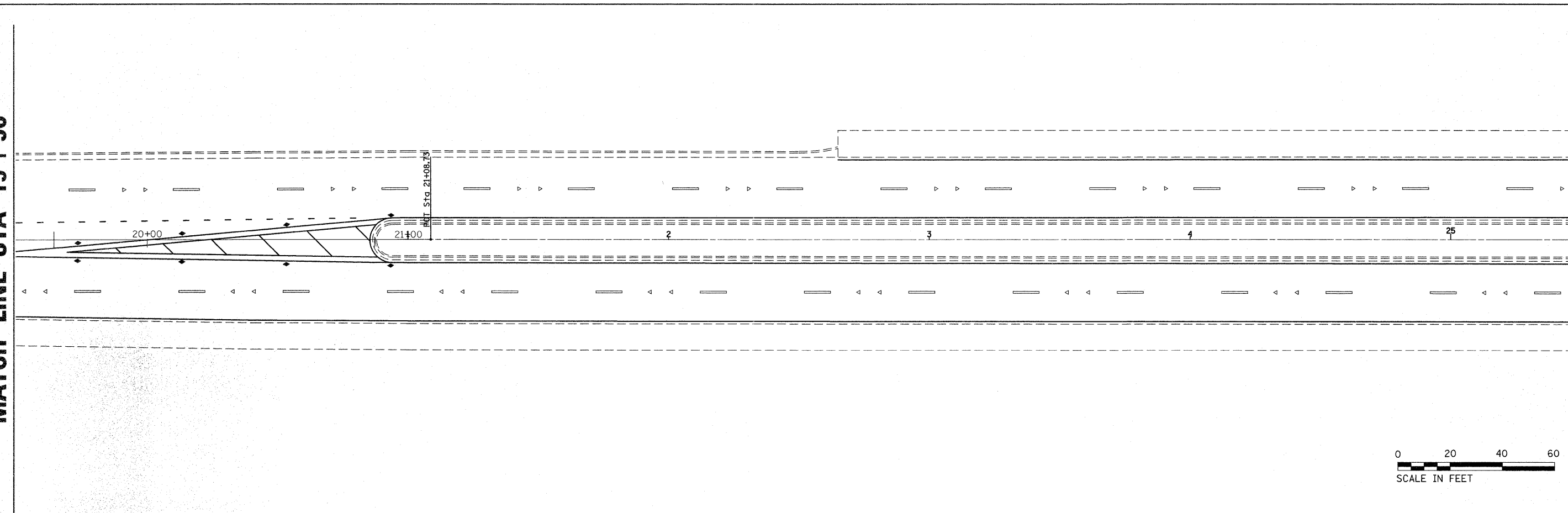

FILE NAME =	USER NAME = leaf.jw	DESIGNED -	REVISED -	<b>STATE OF ILLINOIS DEPARTMENT OF TRANSPORTATION</b>	<b>PLAN SHEET</b>				F.A.P. RTE.	SECTION	COUNTY	TOTAL SHEETS	SHEET NO.
c:\pw_work\pwsdot\vasgleyml\d0282391\ED06604-sht-plan.dgn		DRAWN -	REVISED -		330	(1,1R-2)RS	KANKAKEE	54	28				
PLOT SCALE = 20.0000' / 1"		CHECKED -	REVISED -		SCALE: 1"=20'				SHEET OF SHEETS STA. TO STA.		CONTRACT NO. 66477		
PLOT DATE = 12/20/2011		DATE -	REVISED -		ILLINOIS FED. AID PROJECT								



MATCH LINE STA 25 + 50

MATCH LINE STA 31 + 50

MATCH LINE STA 31 + 50

MATCH LINE STA 37 + 50

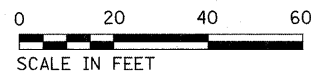
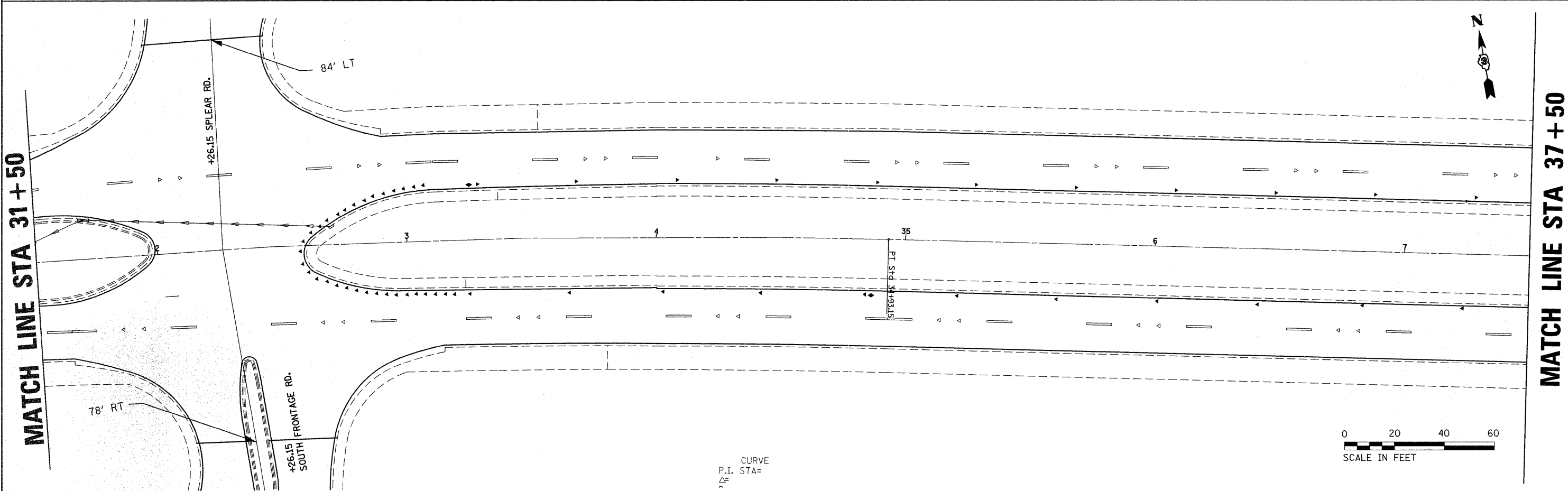
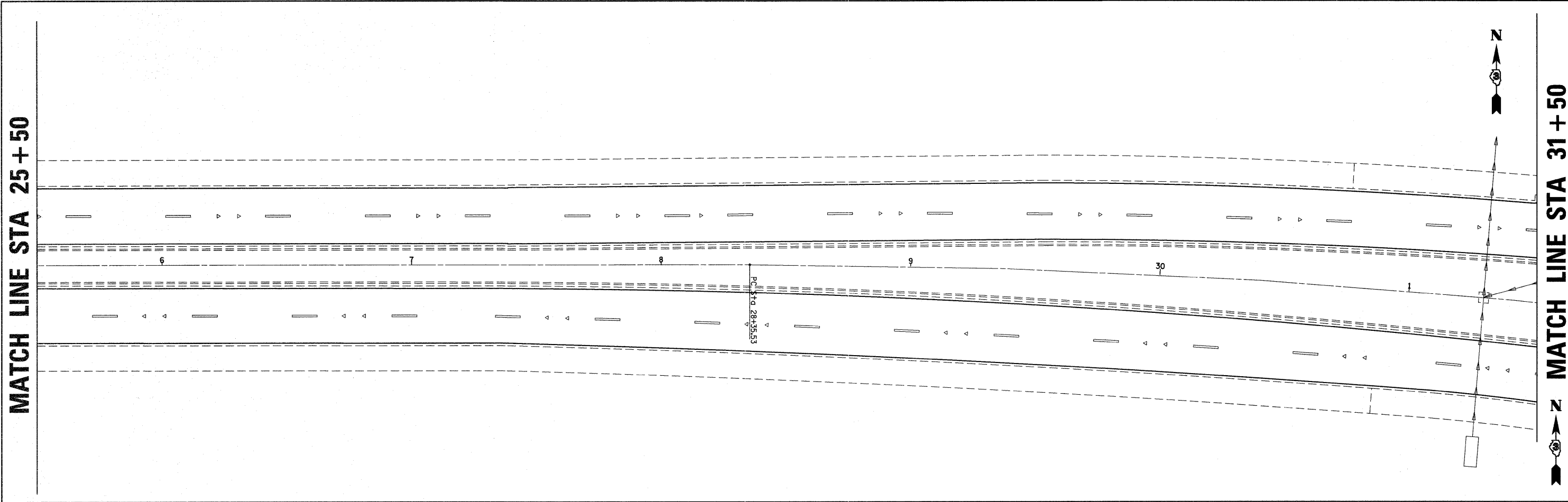

CURVE  
P.I. STA=  
Δ=

FILE NAME =  
c:\pwwork\pwwork\qungleym\1\0282391\ED026604-ah-plan.dgn

USER NAME = leaf\_jw  
PLOT SCALE = 20.0000' / 1in.  
PLOT DATE = 12/20/2011

DESIGNED -  
DRAWN -  
CHECKED -  
DATE -

REVISED -  
REVISED -  
REVISED -  
REVISED -

**STATE OF ILLINOIS  
DEPARTMENT OF TRANSPORTATION**

**PLAN SHEET**

SCALE: 1"=20' SHEET OF SHEETS STA. TO STA.

F.A.P. RTE.	SECTION	COUNTY	TOTAL SHEETS	SHEET NO.
330	(1,1R-2)RS	KANKAKEE	54	29
CONTRACT NO. 66477				
ILLINOIS FED. AID PROJECT				

MATCH LINE STA 37+50

MATCH LINE STA 43+50

MATCH LINE STA 43+50

MATCH LINE STA 49+50

P.C. STA= 37+63.20

CURVE  
 P.I. STA=  
 $\Delta$ =  
 D=  
 R=  
 T=  
 E=  
 $\theta$ =  
 P.T. STA=  
 S.E. RUN=  
 P.C. STA=  
 P.T. STA=

36' PCCP

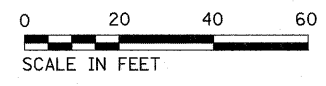

FILE NAME =	USER NAME = leaf.jw	DESIGNED -	REVISED -
c:\pwwork\pwwork\project\1\02282391\ED066604-shr-plan.dgn		DRAWN -	REVISED -
	PLOT SCALE = 20.0000' / 1"	CHECKED -	REVISED -
	PLOT DATE = 12/20/2011	DATE -	REVISED -

STATE OF ILLINOIS  
 DEPARTMENT OF TRANSPORTATION

PLAN SHEET

SCALE: 1"=20' SHEET OF SHEETS STA. TO STA.

F.A.P. RTE.	SECTION	COUNTY	TOTAL SHEETS	SHEET NO.
330	(1,1R-2)RS	KANKAKEE	54	30
CONTRACT NO. 66477				
ILLINOIS FED. AID PROJECT				

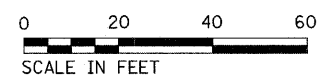
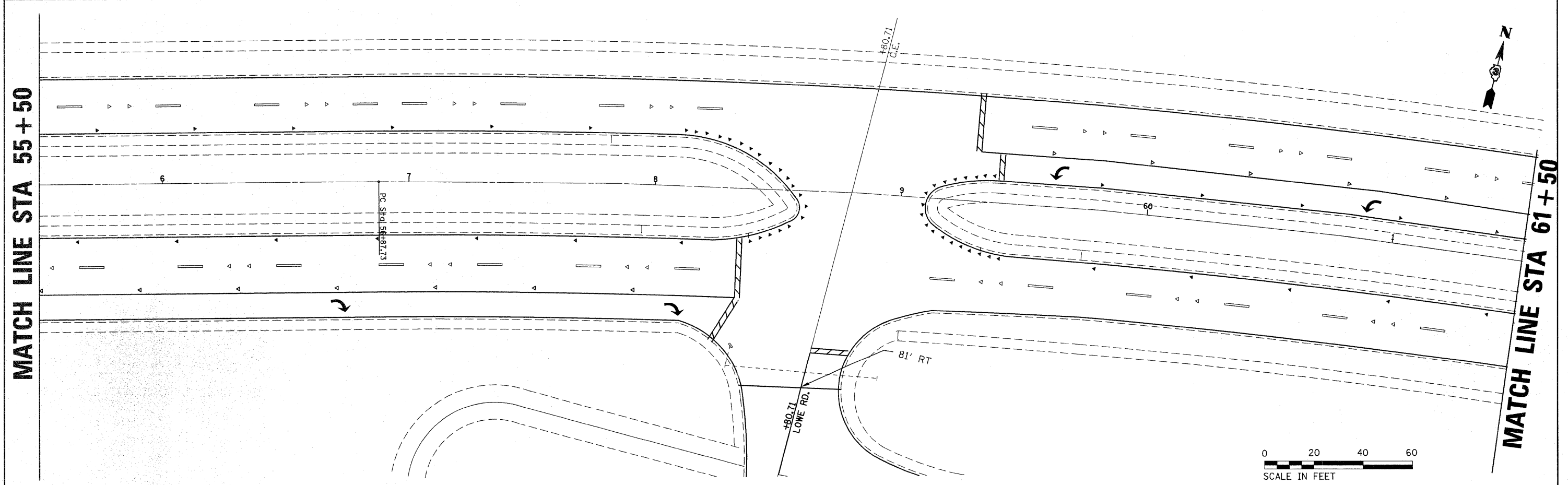
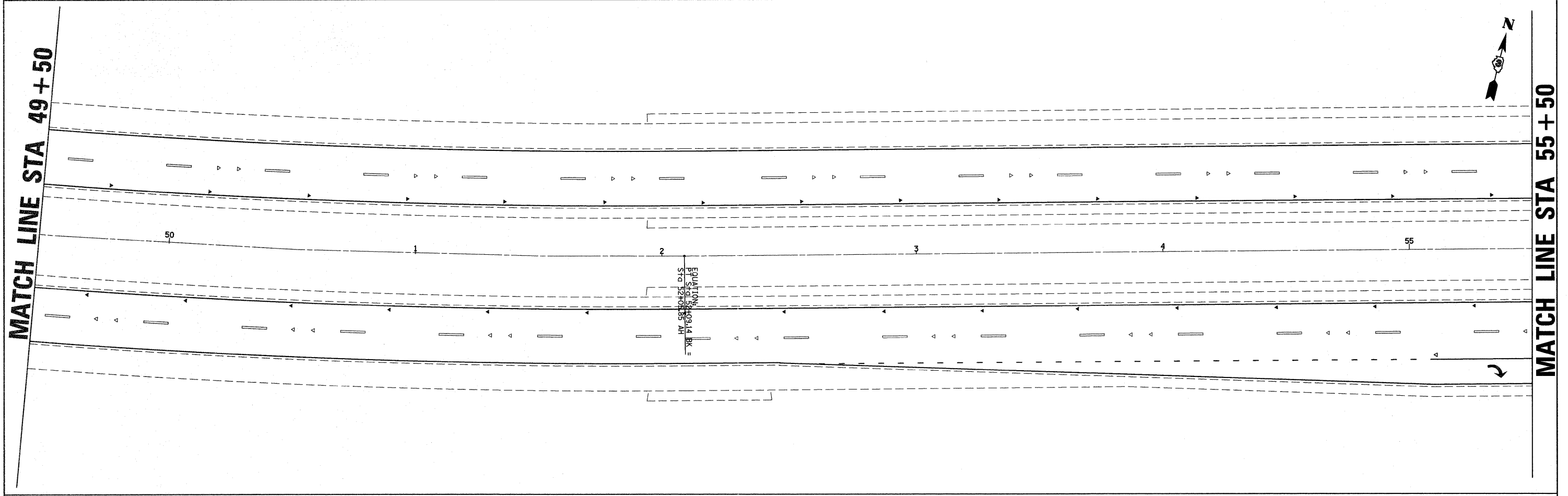

FILE NAME =	USER NAME = leef.jw	DESIGNED -	REVISED -	<b>STATE OF ILLINOIS DEPARTMENT OF TRANSPORTATION</b>	<b>PLAN SHEET</b>	F.A.P. RTE.	SECTION	COUNTY	TOTAL SHEETS	SHEET NO.	
ct:\pw_work\pwsdot\qsigleym\1\0282391\ED066624-sht-plan.dgn		DRAWN -	REVISED -			330	(1,1R-2)RS	KANKAKEE	54	31	
PLOT SCALE = 20.0000' / in.		CHECKED -	REVISED -			CONTRACT NO. 66477					
PLOT DATE = 12/20/2011		DATE -	REVISED -			ILLINOIS FED. AID PROJECT					

SCALE: 1"=20' SHEET OF SHEETS STA. TO STA.

MATCH LINE STA 61+50



MATCH LINE STA 67+50

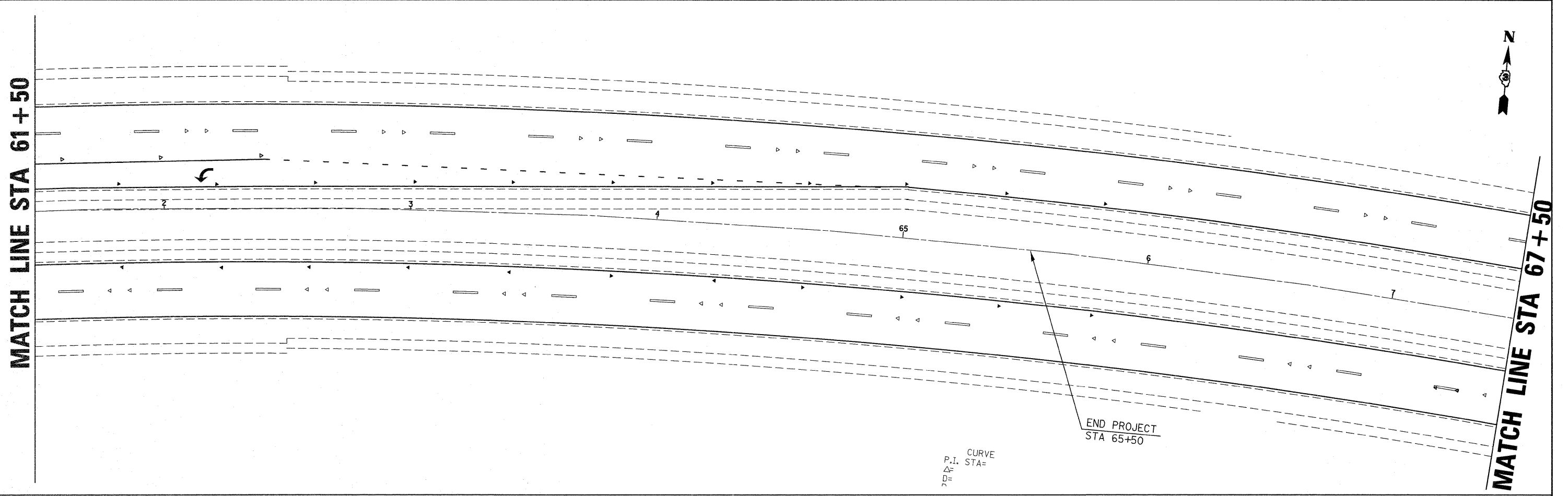

MATCH LINE STA 67+50

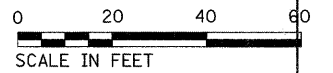

FILE NAME =	USER NAME = leaf_jw	DESIGNED -	REVISED -	<b>STATE OF ILLINOIS DEPARTMENT OF TRANSPORTATION</b>	<b>PLAN SHEET</b>				F.A.P. RTE.	SECTION	COUNTY	TOTAL SHEETS	SHEET NO.
c:\pw_work\pwsdot\qsigleym\1d0282391\ED06604-ahp-plan.dgn		DRAWN -	REVISED -		330	(1,1R-2)RS	KANKAKEE	54	32				
PLOT SCALE = 20.0000' / 1"		CHECKED -	REVISED -		SCALE: 1"=20' SHEET OF SHEETS STA. TO STA.				CONTRACT NO. 66477				
PLOT DATE = 12/20/2011		DATE -	REVISED -		ILLINOIS FED. AID PROJECT								

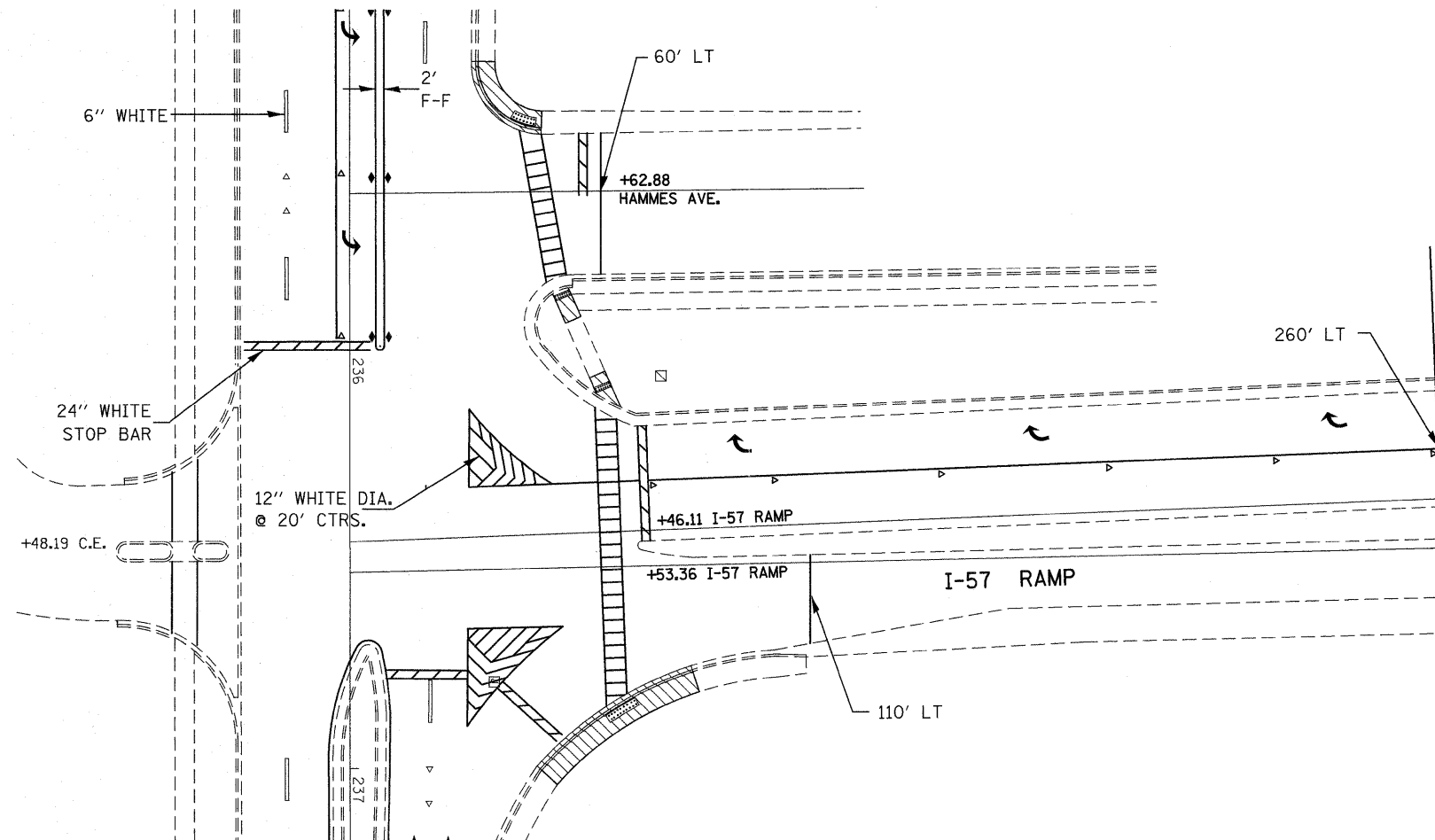

# SB I-57 RAMP

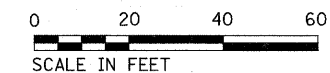

FILE NAME =	USER NAME = leef_jw	DESIGNED -	REVISED -	<b>STATE OF ILLINOIS DEPARTMENT OF TRANSPORTATION</b>	<b>SB I-57 RAMP PLAN SHEET</b>		F.A.P. RTE.	SECTION	COUNTY	TOTAL SHEETS	SHEET NO.	
c:\pw_work\pwsdot\qunglegm\10282391\ED06604-shr-plan.dgn		DRAWN -	REVISED -		330	(1,1R-2)RS	KANKAKEE	54	33			
		CHECKED -	REVISED -		SCALE: 1"=20'		SHEET OF SHEETS		STA. TO STA.		CONTRACT NO. 66477	
		DATE -	REVISED -		ILLINOIS FED. AID PROJECT							

TRAFFIC SIGNAL CONSTRUCTION SUMMARY

1. Only the westbound left turn detector loops on Illinois 17 will be removed by the milling operation. Detector loops for the other three legs of the intersection installed on a separate contract.
2. Northeast quadrant: Drill existing handhole to insert two 1-1/2" conduits for the tails of the new detectors.

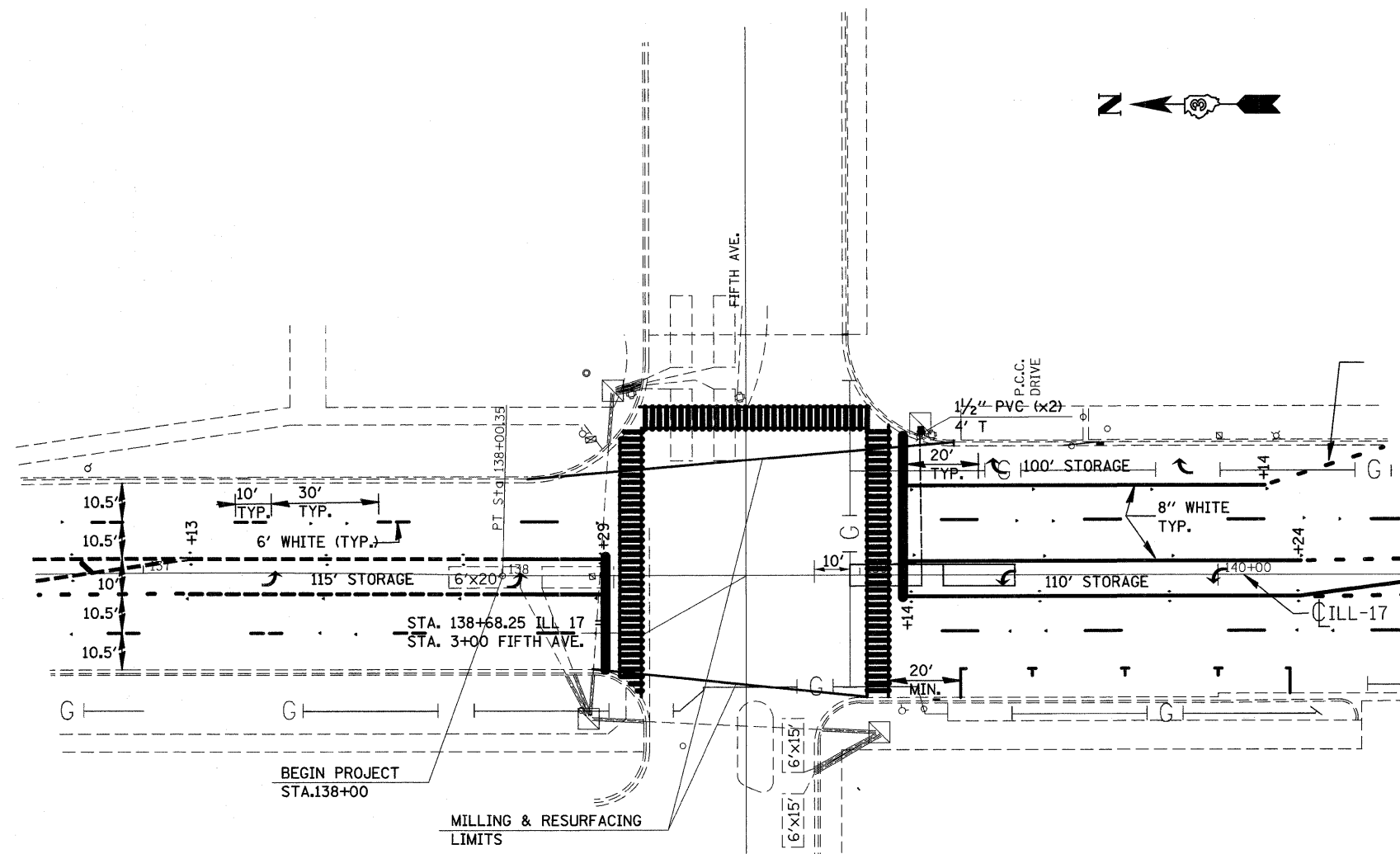

SCHEDULE OF QUANTITIES		
CONDUIT IN TRENCH, 1 1/2" DIA., PVC	FOOT	8
DRILL EXISTING HANDHOLE	EACH	2
DETECTOR LOOP, TYPE I	FOOT	174
TRENCH AND BACKFILL FOR ELECTRICAL WORK	FOOT	4

DETECTOR LOOP INDUCTANCE CHART IL ROUTE 17 & FIFTH AVE				
LOOP SYSTEM	LABEL	NO. OF TURNS	INDUCTANCE (uH)	FREQUENCY Hertz
A	WBLT	3	353	32478

**FOR INFORMATION ONLY**

FILE NAME =	USER NAME = leaf.jw	DESIGNED -	REVISED -	<b>STATE OF ILLINOIS DEPARTMENT OF TRANSPORTATION</b>	<b>IL 17 AND 5TH AVENUE DETECTOR LOOP INFORMATION</b>			F.A.P. RTE.	SECTION	COUNTY	TOTAL SHEETS	SHEET NO.
ct:\pw_work\p\dot\quigley\m1\d0282391\ED06624-shd-details.dgn		DRAWN -	REVISED -		330	(1,1R-2)RS	KANKAKEE	54	34			
PLOT SCALE = 50,0000' / 1" =		CHECKED -	REVISED -		SCALE: SHEET NO. OF SHEETS STA. TO STA.			CONTRACT NO. 66477				
PLOT DATE = 12/28/2011		DATE -	REVISED -		ILLINOIS FED. AID PROJECT							

This document and the ideas and designs incorporated herein, as an instrument of professional service, is the property of Tyson Engineering, Inc. and is not to be used in whole or in part, for any other project without written authorization of Tyson Engineering, Inc.

Do not scale drawings. Use dimensions only.  
 Contractor shall be responsible for verifying all dimensions.  
 Information herein and herein is confidential.

REVISIONS			
NO.	DATE	BY	DESCRIPTION
1	06/07/01	LIC	PER IDOT REVIEW

**CITY OF KANKAKEE  
 INFRASTRUCTURE**

**TRAFFIC SIGNAL PLAN  
 TO SERVE  
 ILLINOIS ROUTE 17  
 & FOURTH AVENUE  
 KANKAKEE, ILLINOIS**

**WIRING PLAN**

- LEGEND**
- IRON PIPE RECOVERED
  - IRON ROD RECOVERED
  - + CUT CROSS IN CONCRETE
  - "P.K." NAIL SET
  - IRON ROD SET
  - ⊗ EX. POWER POLE
  - ⊕ EX. STREET LIGHT
  - ⊖ EX. LIGHT POLE
  - ⊙ EX. FIRE HYDRANT
  - ⊗ EX. WATER VALVE
  - ⊙ EX. WATER METER
  - OE— EX. OVERHEAD ELECTRIC
  - OT— EX. OVERHEAD TELEPHONE
  - ▽— EX. STORM SEWER
  - S— EX. SANITARY SEWER
  - G— NORTHERN ILLINOIS GAS LINE
  - ⊙ EX. SIGNAL BOX
  - ⊙ EX. TRAFFIC SIGNAL
  - ⊙ EX. SIGNAL VAULT
  - ⊙ EX. COM-ED BOX
  - ⊙ EX. TELEVISION PEDESTAL
  - ⊙ EX. WALK SIGNAL
  - ⊙ EX. MANHOLE
  - ⊙ EX. CATCH BASIN
  - ⊙ EX. INLET
  - ⊙ EX. ELECTRIC VAULT
  - ⊙ EX. MISCELLANEOUS SIGN
  - ⊙ EX. GUY POLE
  - ⊙ EX. GUY WIRE
  - ⊙ PR. TRAFFIC SIGNAL CONTROLLER CABINET
  - ⊙ PR. STEEL COMBINATION MAST ARM ASSEMBLY AND POLE
  - ⊙ PR. TRAFFIC SIGNAL HEAD WITH BACK PLATE
  - ⊙ PR. PEDESTRIAN SIGNAL HEAD
  - ⊙ PR. PEDESTRIAN PUSH BUTTON
  - ⊙ PR. CONCRETE HANDHOLE

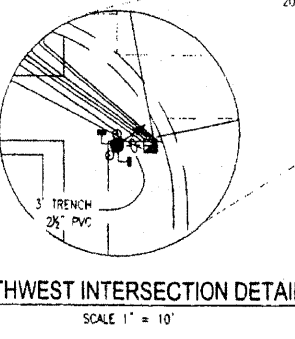
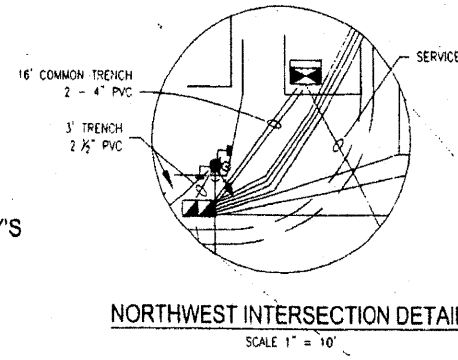
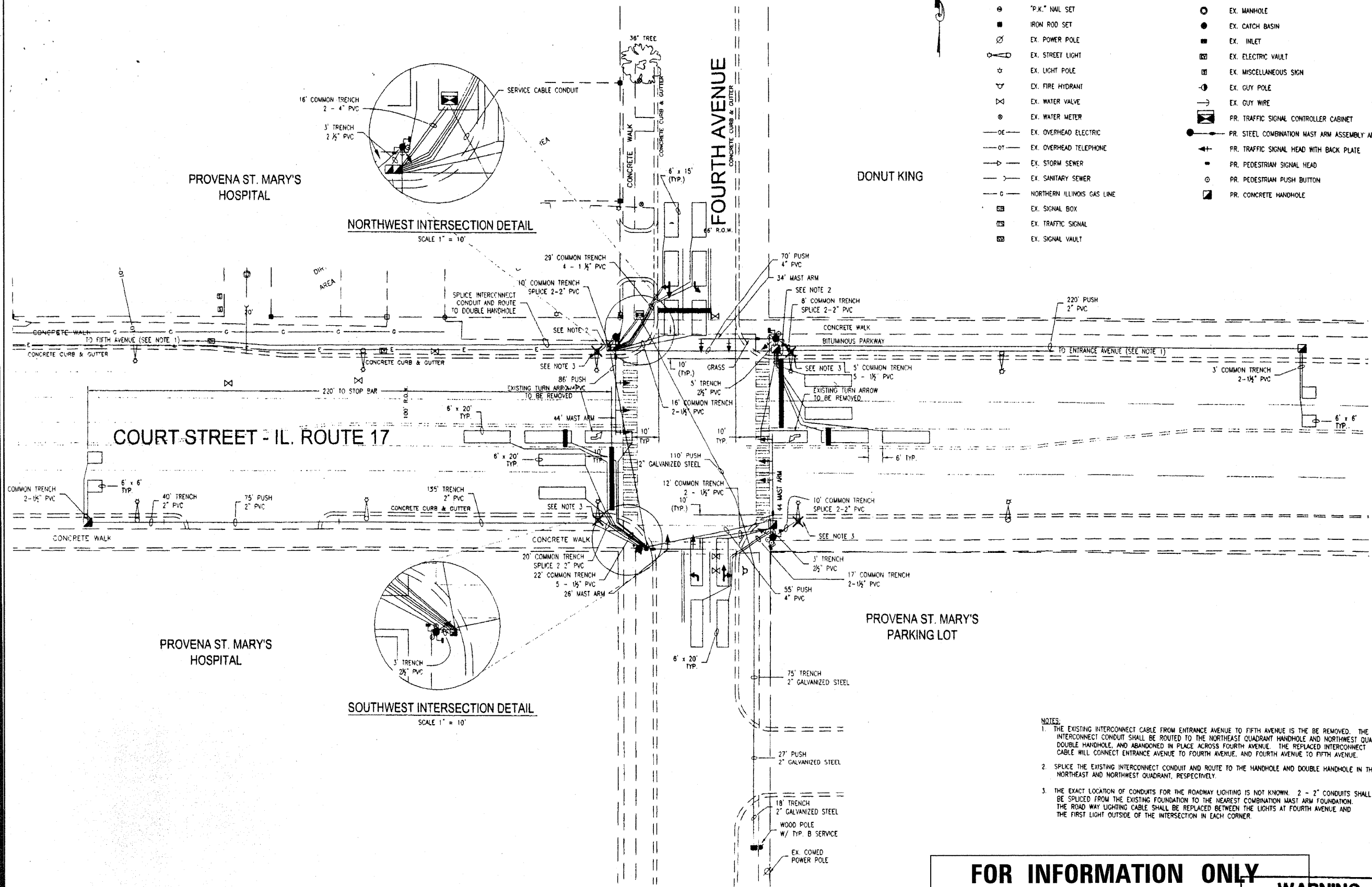

- NOTES:**
- THE EXISTING INTERCONNECT CABLE FROM ENTRANCE AVENUE TO FIFTH AVENUE IS TO BE REMOVED. THE INTERCONNECT CONDUIT SHALL BE ROUTED TO THE NORTHEAST QUADRANT HANDHOLE AND NORTHWEST QUADRANT DOUBLE HANDHOLE, AND ABANDONED IN PLACE ACROSS FOURTH AVENUE. THE REPLACED INTERCONNECT CABLE WILL CONNECT ENTRANCE AVENUE TO FOURTH AVENUE, AND FOURTH AVENUE TO FIFTH AVENUE.
  - SPLICE THE EXISTING INTERCONNECT CONDUIT AND ROUTE TO THE HANDHOLE AND DOUBLE HANDHOLE IN THE NORTHEAST AND NORTHWEST QUADRANT, RESPECTIVELY.
  - THE EXACT LOCATION OF CONDUITS FOR THE ROADWAY LIGHTING IS NOT KNOWN. 2 - 2\"/>

**FOR INFORMATION ONLY**

FILE NAME =	USER NAME = leaf.jw	DESIGNED -	REVISED -
ct:\pw\work\pwwdot\quigley\1\40282391\ED06604-eh-t-detail.dgn		DRAWN -	REVISED -
		CHECKED -	REVISED -
		DATE -	REVISED -

**STATE OF ILLINOIS  
 DEPARTMENT OF TRANSPORTATION**

<b>IL 17 AND 4TH AVENUE    DETECTOR LOOP INFORMATION</b>			
SCALE:	SHEET NO. OF SHEETS	STA. TO STA.	

F.A.P. RTE.	SECTION	COUNTY	TOTAL SHEETS	SHEET NO.
330	(1,1R-2)RS	KANKAKEE	54	35
CONTRACT NO. 66477				
ILLINOIS FED. AID PROJECT				



TRAFFIC SIGNAL CONSTRUCTION SUMMARY

1. Detector loops on Illinois 17 are existing and will be removed by the milling operation. Replace the detector loops as shown.
2. Existing detector loop lead-in cable shall be tested prior to splicing onto the new detector loop. Existing detector loop lead-in testing good shall be reused. Testing of the existing detector loop and lead-in cable shall be included in the price for Detector Loop Type I.
3. The contractor shall perform detector testing on the existing loops remaining at this intersection to confirm they remain intact. Damaged loops may be replaced at the direction of the resident.
4. The northbound and southbound detector loops are new.
5. Install inductive loop detectors, harnesses, and necessary parts to place the new inductive loop detectors in operation.
6. Southeast quadrant: Remove sidewalk as necessary. Drill existing handhole to insert two 1-1/2" conduits for the tails of the new detectors.
7. Northwest quadrant: Remove sidewalk as necessary. Drill existing handhole to insert one 1-1/2" conduits for the tail of the new detectors.

SCHEDULE OF QUANTITIES			
CONDUIT IN TRENCH, 1 1/2" DIA., PVC	FOOT	12	
ELECTRIC CABLE IN TRENCH, LEAD-IN, NO. 14 1 PAIR	FOOT	230	
DRILL EXISTING HANDHOLE	EACH	3	
INDUCTIVE LOOP DETECTOR (SPECIAL)	EACH	2	
DETECTOR LOOP, TYPE I	FOOT	703	
PORTLAND CEMENT CONCRETE SIDEWALK 4 INCH	SQ FT	72	
SIDEWALK REMOVAL	SQ FT	72	
TRENCH BACKFILL FOR ELECTRICAL WORK	FOOT	8	

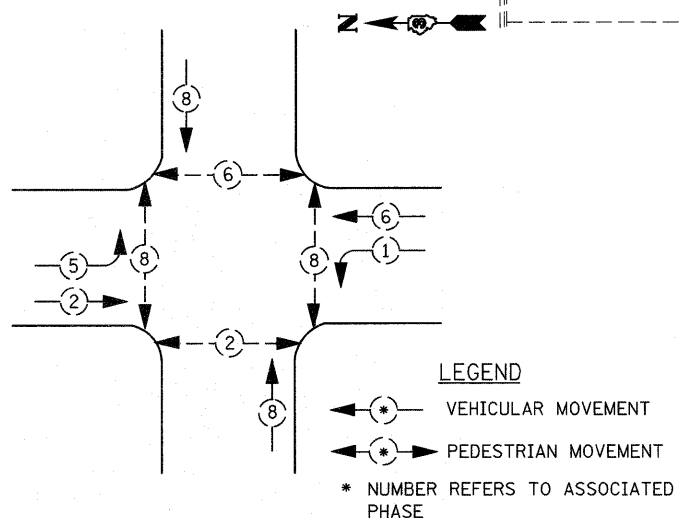
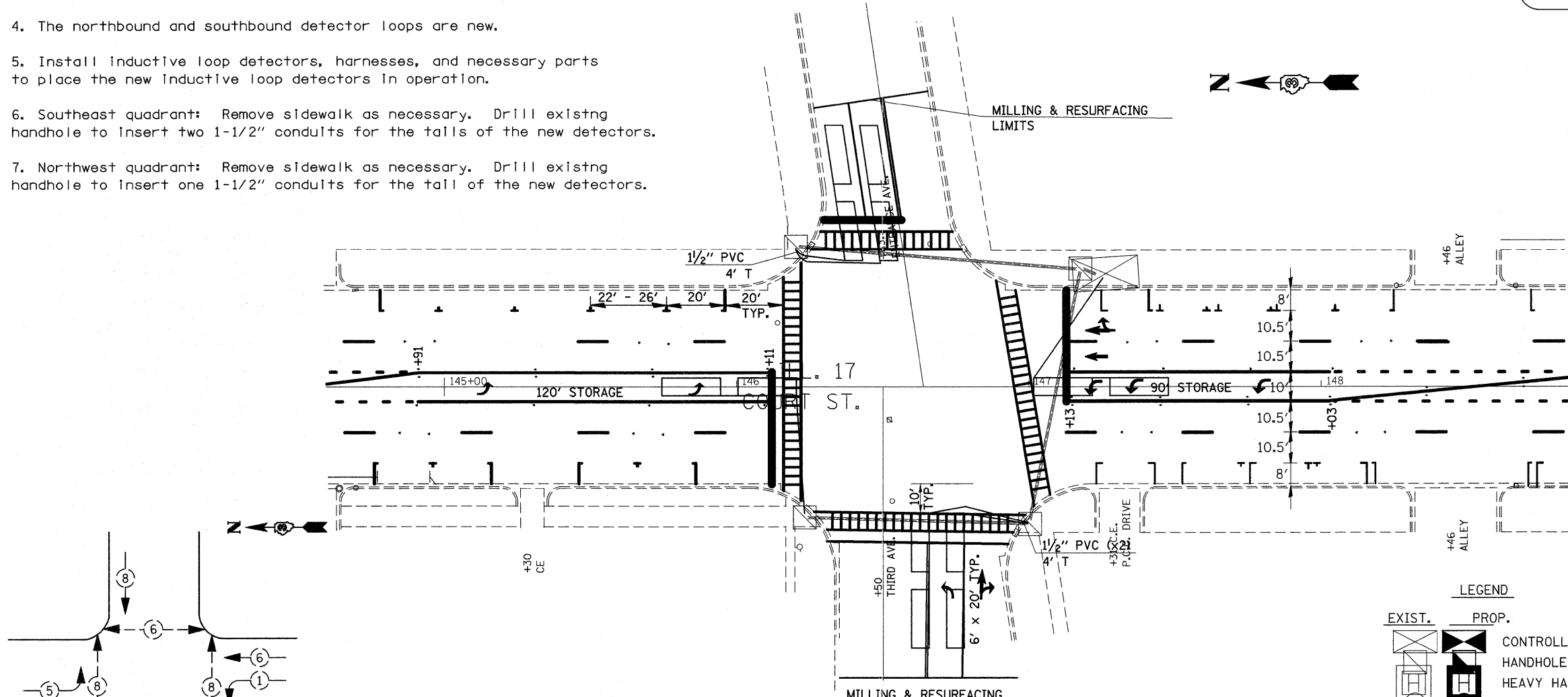
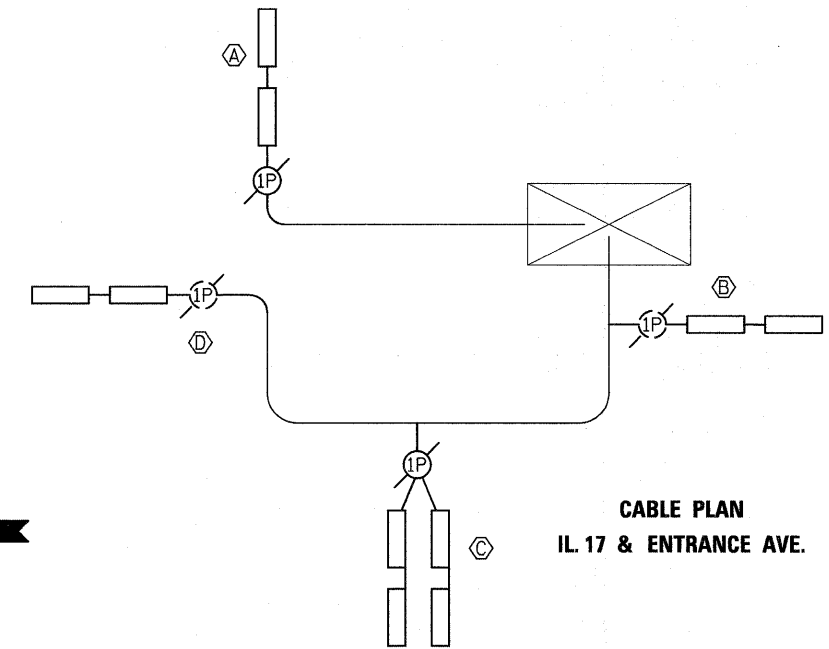

EXISTING PHASE DESIGNATION DIAGRAM  
IL 17 & ENTRANCE AVENUE

DETECTOR LOOP INDUCTANCE CHART IL ROUTE 17 & ENTRANCE AVE				
LOOP SYSTEM	LABEL	NO. OF TURNS	INDUCTANCE (uH)	FREQUENCY (Hertz)
A	SB	3	341	33049
B	WBLT	3	324	33902
C	NB	3	660	23759
D	EBLT	3	365	31926

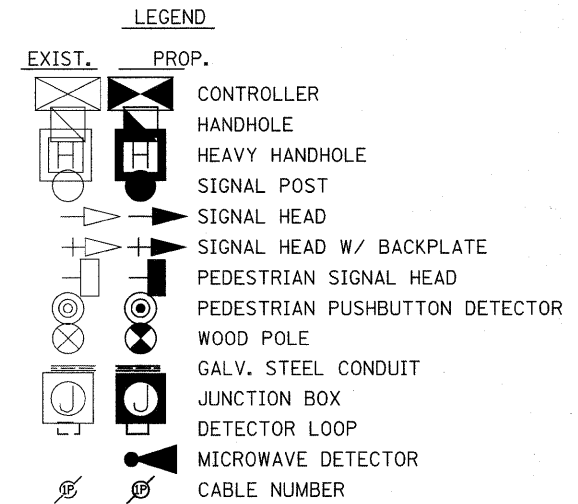

**FOR INFORMATION ONLY**

TRAFFIC SIGNAL CONSTRUCTION SUMMARY

1. Detector loops on Illinois 17 are existing and will be removed by the milling operation. Replace the detector loops as shown.
2. Existing detector loop lead-in cable shall be tested prior to splicing onto the new detector loop. Existing detector loop lead-in testing good shall be reused. Testing of the existing lead-in cable shall be included in the price for Detector Loop Type I.
3. The contractor shall perform detector testing on the existing loops remaining at this intersection to confirm they remain intact. Damaged loops may be replaced at the direction of the resident.
4. The southbound detector loops are new. The northbound detector loops are being installed on a separate contract.
5. Install inductive loop detectors, harnesses, and necessary parts to place the new inductive loop detectors in operation.
6. Northwest quadrant: Remove pavement as necessary. Drill existing handhole to insert four 1-1/2" conduits for the tails of MILLING & RESURFACING LIMITS
7. Eastbound left turn lane: It is unknown whether the existing detector loops for the eastbound left turn lane are spliced in the mast arm shaft on the northwest quadrant or in the handhole in the eastbound left turn lane. The contractor shall discover the actual location and cut the tail of the new detector to meet the existing dive hole conduit.

SCHEDULE OF QUANTITIES		
CONDUIT IN TRENCH, 1 1/2" DIA., PVC	FOOT	16
ELECTRIC CABLE IN CONDUIT, LEAD-IN, NO. 14 1 PAIR	FOOT	40
DRILL EXISTING HANDHOLE	EACH	4
INDUCTIVE LOOP DETECTOR (SPECIAL)	EACH	2
DETECTOR LOOP, TYPE I	FOOT	642
TRENCH AND BACKFILL FOR ELECTRICAL WORK	FOOT	16
INCIDENTAL BITUMINOUS SURFACING	TON	0.74
DETECTOR TESTING	EACH	1

CONSTRUCTION NOTES

1. Remove pavement as necessary. Drill existing handhole four times.

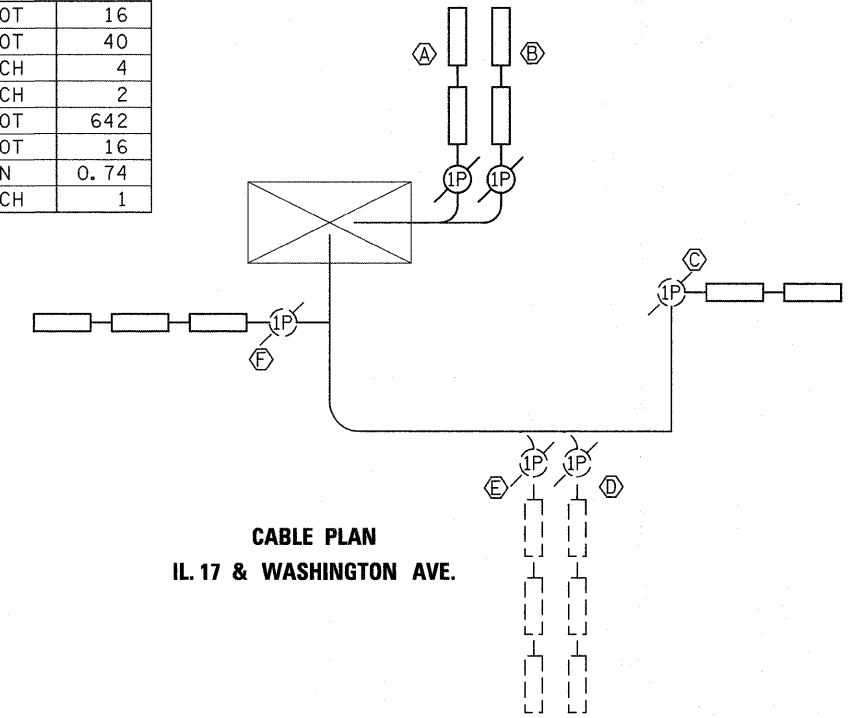

CABLE PLAN  
IL 17 & WASHINGTON AVE.

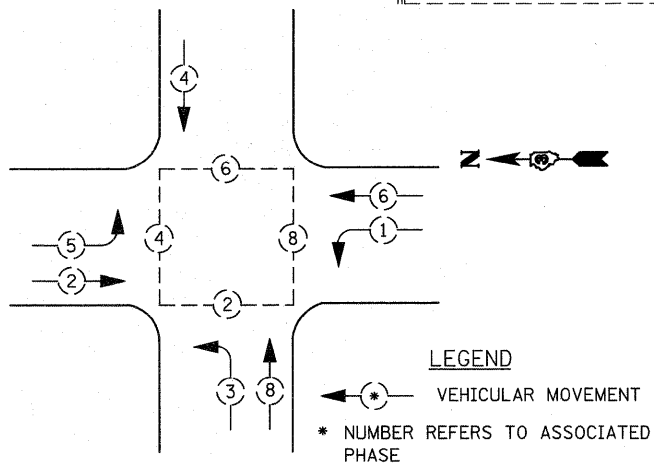
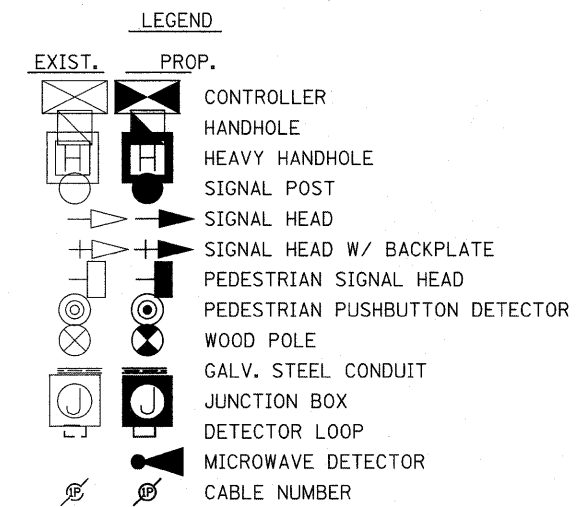
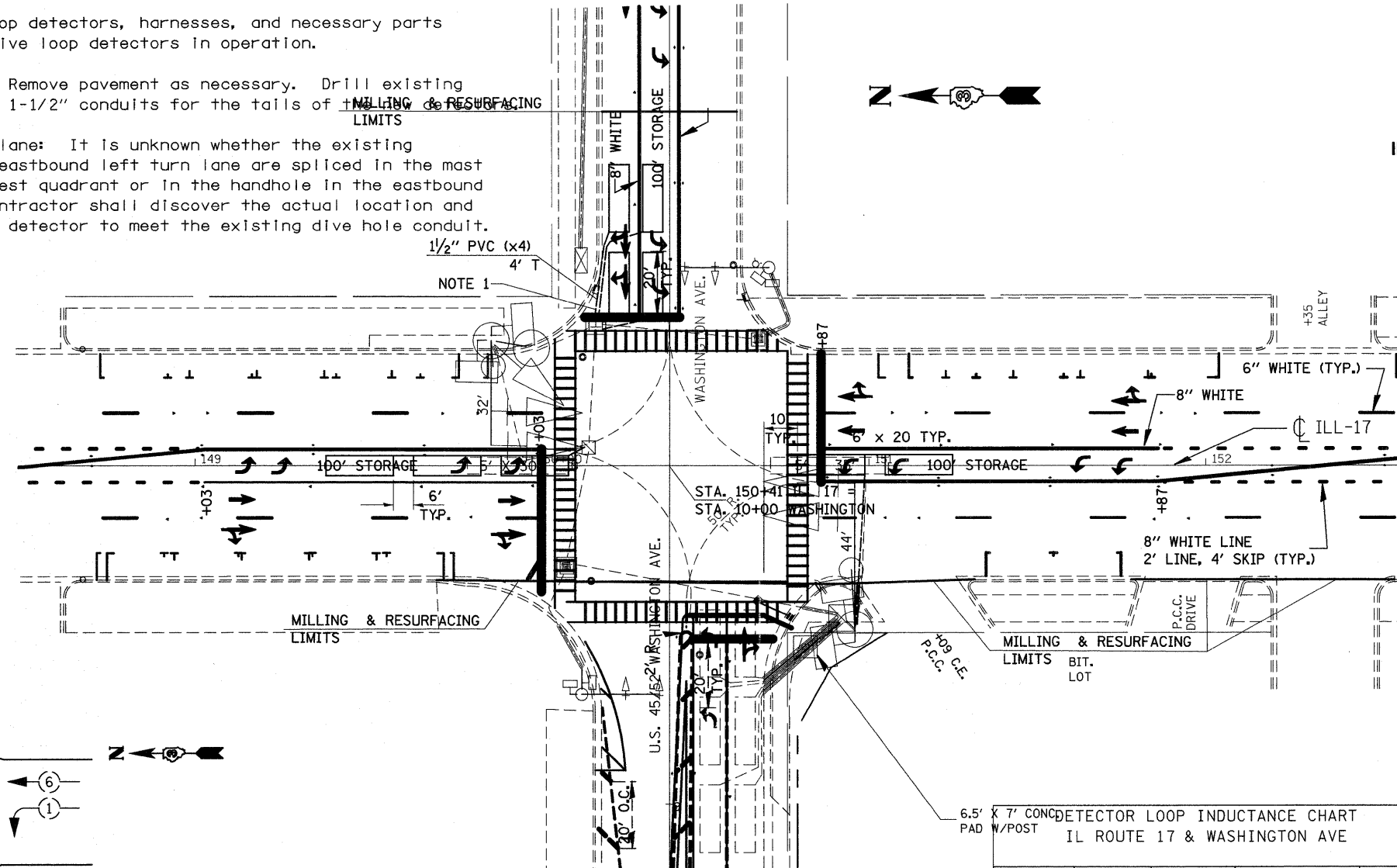

PHASE DESIGNATION DIAGRAM  
IL 17 & WASHINGTON AVENUE

DETECTOR LOOP INDUCTANCE CHART  
IL ROUTE 17 & WASHINGTON AVE

LOOP SYSTEM	LABEL	NO. OF TURNS	INDUCTANCE (uH)	FREQUENCY Hertz
A	SBRL	3	324	33890
B	SBLL	3	327	33731
C	WBLT	3	370	31726
D	NBRL	*	*	*
E	NBLL	*	*	*
F	EBLT	3	488	27615

**FOR INFORMATION ONLY**

TRAFFIC SIGNAL CONSTRUCTION SUMMARY

1. Detector loops on Illinois 17 are existing and will be removed by the milling operation. Replace the detector loops as shown.
2. Existing detector loop lead-in cable shall be tested prior to splicing onto the new detector loop. Existing detector loop lead-in testing good shall be reused. Testing of the existing lead-in cable shall be included in the price for Detector Loop Type I.
3. The northbound and southbound detector loops are new.
4. Install inductive loop detectors, harnesses, and necessary parts to place the new inductive loop detectors in operation.
5. Southeast quadrant: Remove pavement as necessary. Drill existing handhole to insert two 1-1/2" conduits for the tails of the new detectors. Fill and compact the hole with the removed material as required. Replace the pavement with incidental bituminous to a final total depth of 12 inches.
6. Northwest quadrant: Remove pavement as necessary. Drill existing handhole to insert two 1-1/2" conduits for the tails of the new detectors. Fill and compact the hole with the removed material as required. Replace the pavement with incidental bituminous to a final total depth of 12 inches.

SCHEDULE OF QUANTITIES		
CONDUIT IN TRENCH, 1 1/2" DIA., PVC	FOOT	16
ELECTRIC CABLE IN TRENCH, LEAD-IN, NO. 14 1 PAIR	FOOT	257
DRILL EXISTING HANDHOLE	EACH	4
INDUCTIVE LOOP DETECTOR (SPECIAL)	EACH	2
DETECTOR LOOP, TYPE I	FOOT	710
TRENCH AND BACKFILL FOR ELECTRICAL WORK	FOOT	16
INCIDENTAL BITUMINOUS SURFACING	TON	1.5

DETECTOR LOOP INDUCTANCE CHART IL ROUTE 17 & SCHUYLER AVE				
LOOP SYSTEM	LABEL	NO. OF TURNS	INDUCTANCE (uH)	FREQUENCY Hertz
A	SB	3	355	32397
B	WBLT	3	362	32071
C	NB	3	352	32529
D	EBLT	3	368	31811

MILLING & RESURFACING LIMITS

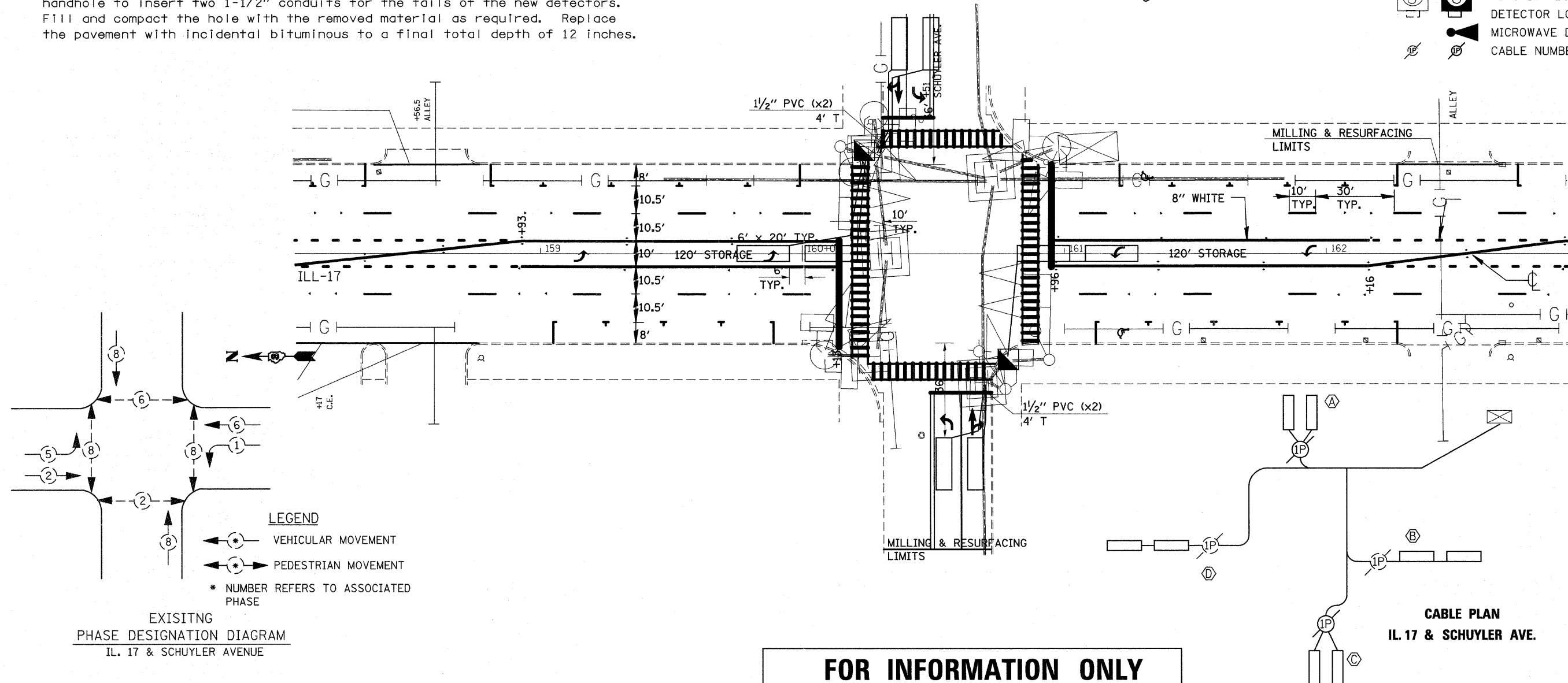
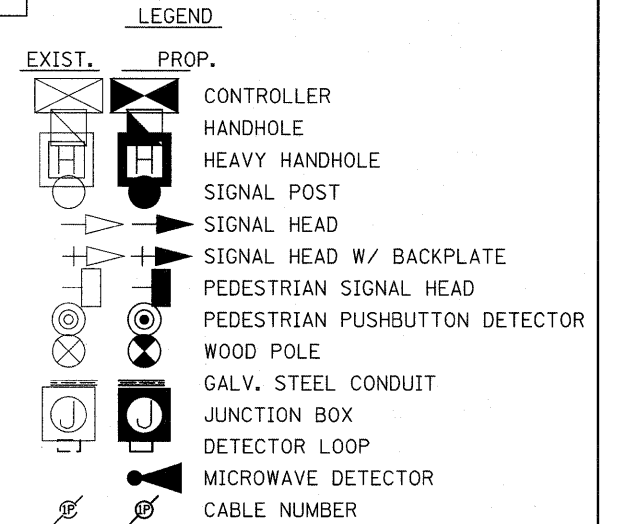

**FOR INFORMATION ONLY**

FILE NAME =	USER NAME = leaf_jw	DESIGNED -	REVISED -	STATE OF ILLINOIS DEPARTMENT OF TRANSPORTATION	IL 17 AND SCHUYLER AVENUE DETECTOR LOOP INFORMATION	F.A.P. RTE.	SECTION	COUNTY	TOTAL SHEETS	SHEET NO.
c:\pwork\pwork\quigley\m\2022391\ED00604-shd-details.dgn	DRAWN -	REVISED -	330			(1,1R-2)RS	KANKAKEE	54	38	
PLOT SCALE = 50.0000' / 1"	CHECKED -	REVISED -	CONTRACT NO. 66477							
PLOT DATE = 12/20/2011	DATE -	REVISED -	ILLINOIS FED. AID PROJECT							

TRAFFIC SIGNAL CONSTRUCTION SUMMARY

1. Detector loops on Illinois 17 are existing and will be removed by the milling operation. Replace the detector loops as shown.
2. Existing detector loop lead-in cable shall be tested prior to splicing onto the new detector loop. Existing detector loop lead-in testing good shall be reused. Testing of the existing lead-in cable shall be included in the price for Detector Loop Type I.
3. The contractor shall perform detector testing on the existing loops remaining at this intersection to confirm they remain intact. Damaged loops may be replaced at the direction of the resident.
4. The southbound detector loops are new.
5. Install inductive loop detector, harnesses, and necessary parts to place the new inductive loop detectors in operation.
6. Northwest quadrant: Remove sidewalk as necessary. Drill existing handhole to insert four 1-1/2" conduits for the tails of the new detector loops.

LOOP SYSTEM	LABEL	NO. OF TURNS	INDUCTANCE (uH)	FREQUENCY Hertz
A	WBLT	3	486	27696
B	NB	3	703	23023

DESCRIPTION	UNIT	QUANTITY
CONDUIT IN TRENCH, 1 1/2" DIA., PVC	FOOT	24
ELECTRIC CABLE IN TRENCH, LEAD-IN, NO. 14 1 PAIR	FOOT	89
DRILL EXISTING HANDHOLE	EACH	4
INDUCTIVE LOOP DETECTOR (SPECIAL)	EACH	1
DETECTOR LOOP, TYPE I	FOOT	628
PORTLAND CEMENT CONCRETE SIDEWALK 4 INCH	SQ FT	24
SIDEWALK REMOVAL	SQ FT	24
TRENCH AND BACKFILL FOR ELECTRICAL WORK	FOOT	7

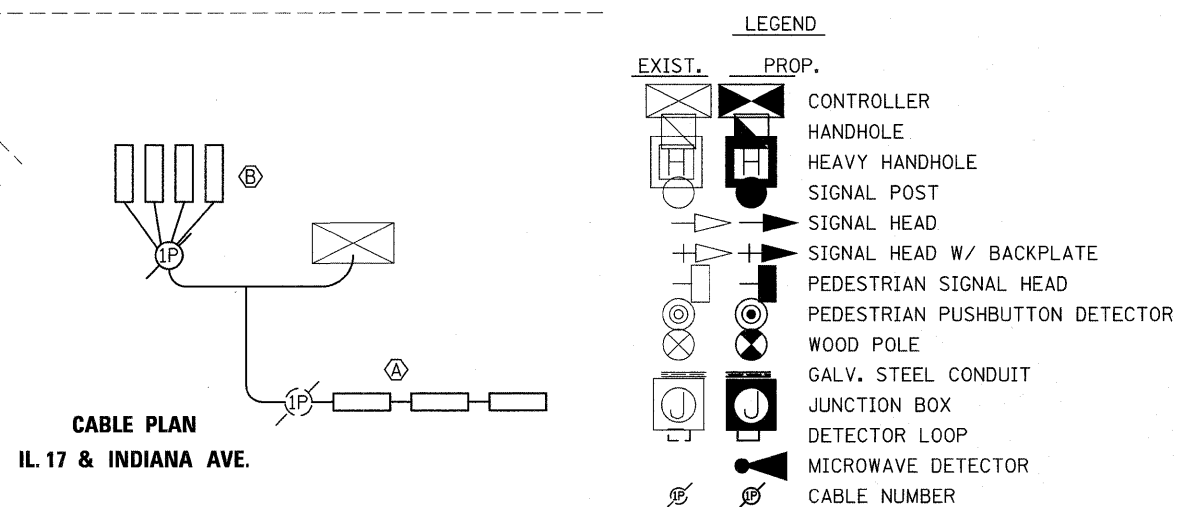
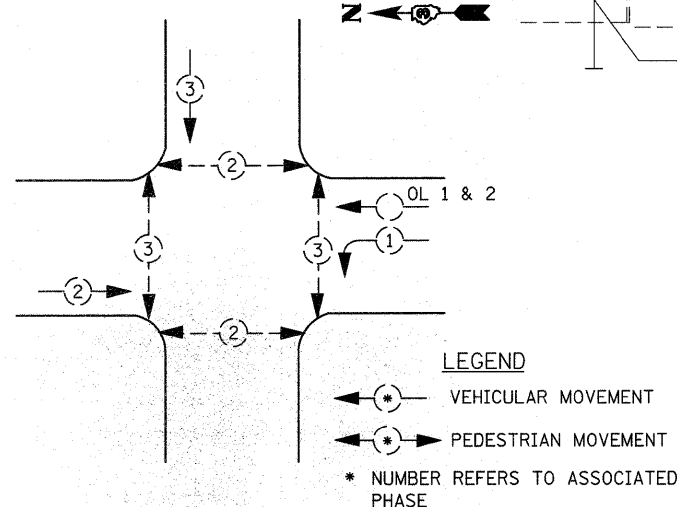
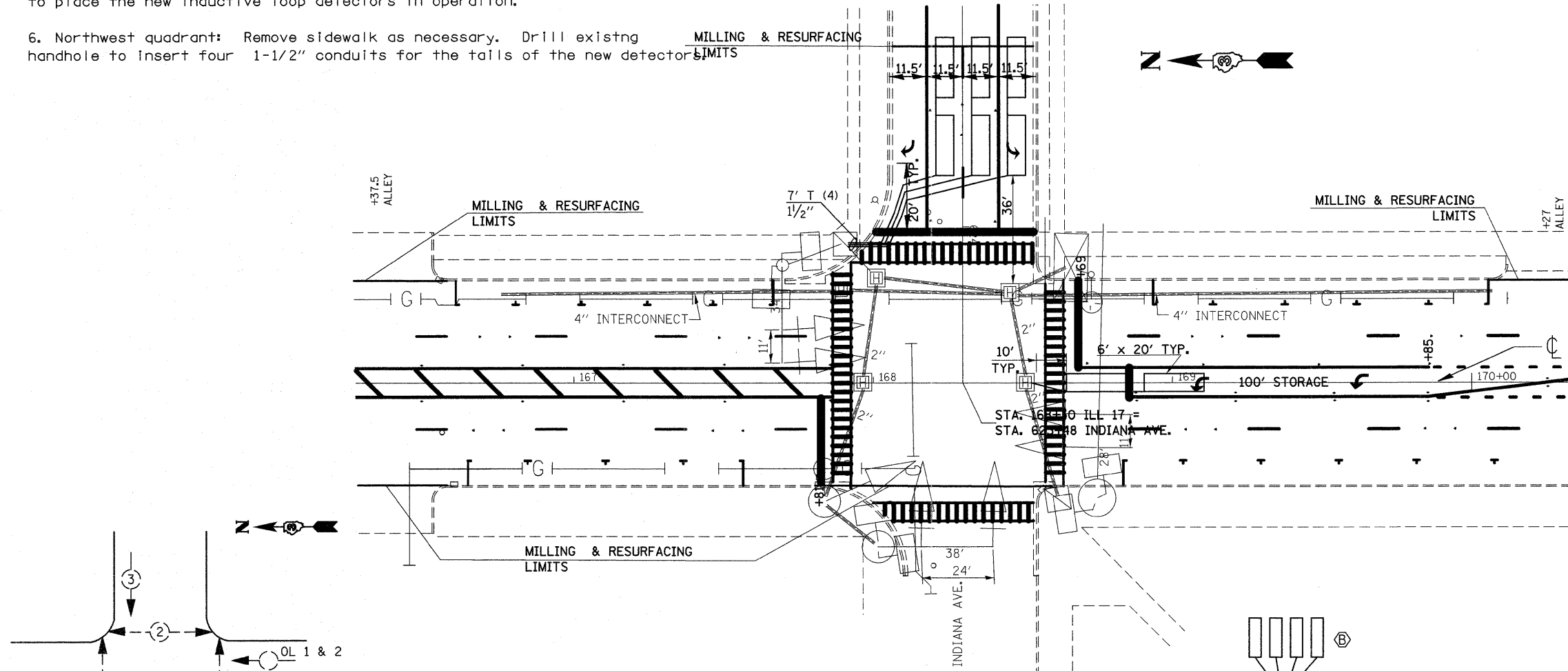

**FOR INFORMATION ONLY**

TRAFFIC SIGNAL CONSTRUCTION SUMMARY

1. Detector loops on Illinois 17 will be removed by the milling operation. Replace the detector loops as shown.
2. Existing detector loop lead-in cable shall be tested prior to splicing onto the new detector loop. Existing detector loop lead-in testing good shall be reused. Testing of the existing lead-in cable shall be included in the price for Detector Loop Type I.
3. The northbound detector loops are new.
4. Install Inductive loop detectors, harnesses, and necessary parts to place the new inductive loop detectors in operation.
5. Southeast quadrant: Remove sidewalk as necessary. Drill existing handhole to insert four 1-1/2" conduits for the tails of the new detectors.

CONSTRUCTION NOTES

1. Remove sidewalk as necessary. Drill existing handhole four times.

SCHEDULE OF QUANTITIES		
CONDUIT IN TRENCH, 1 1/2" DIA., PVC	FOOT	24
ELECTRIC CABLE IN TRENCH, LEAD-IN, NO. 14 1 PAIR	FOOT	106
DRILL EXISTING HANDHOLE	EACH	4
INDUCTIVE LOOP DETECTOR (SPECIAL)	EACH	1
DETECTOR LOOP, TYPE I	FOOT	536
PORTLAND CEMENT CONCRETE SIDEWALK 4 INCH	SQ FT	24
SIDEWALK REMOVAL	SQ FT	24
TRENCH AND BACKFILL FOR ELECTRICAL WORK	FOOT	7

DETECTOR LOOP INDUCTANCE CHART IL ROUTE 17 & HARRISON AVE				
LOOP SYSTEM	LABEL	NO. OF TURNS	INDUCTANCE (uH)	FREQUENCY Hertz
A	WBLT	3	359	32228
B	NB	3	653	23875

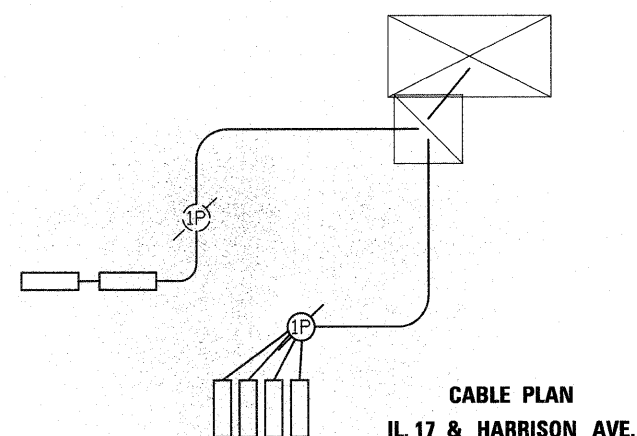
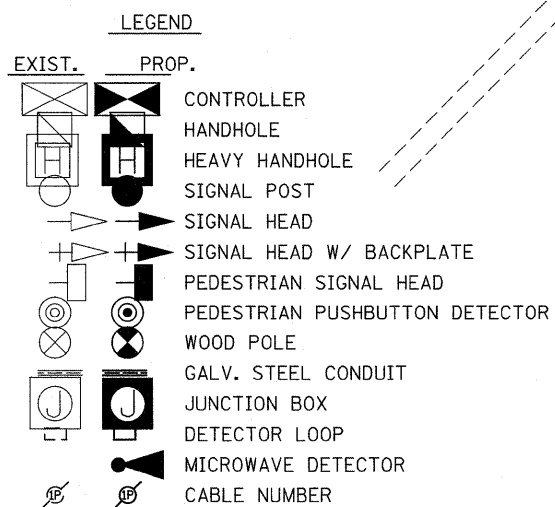
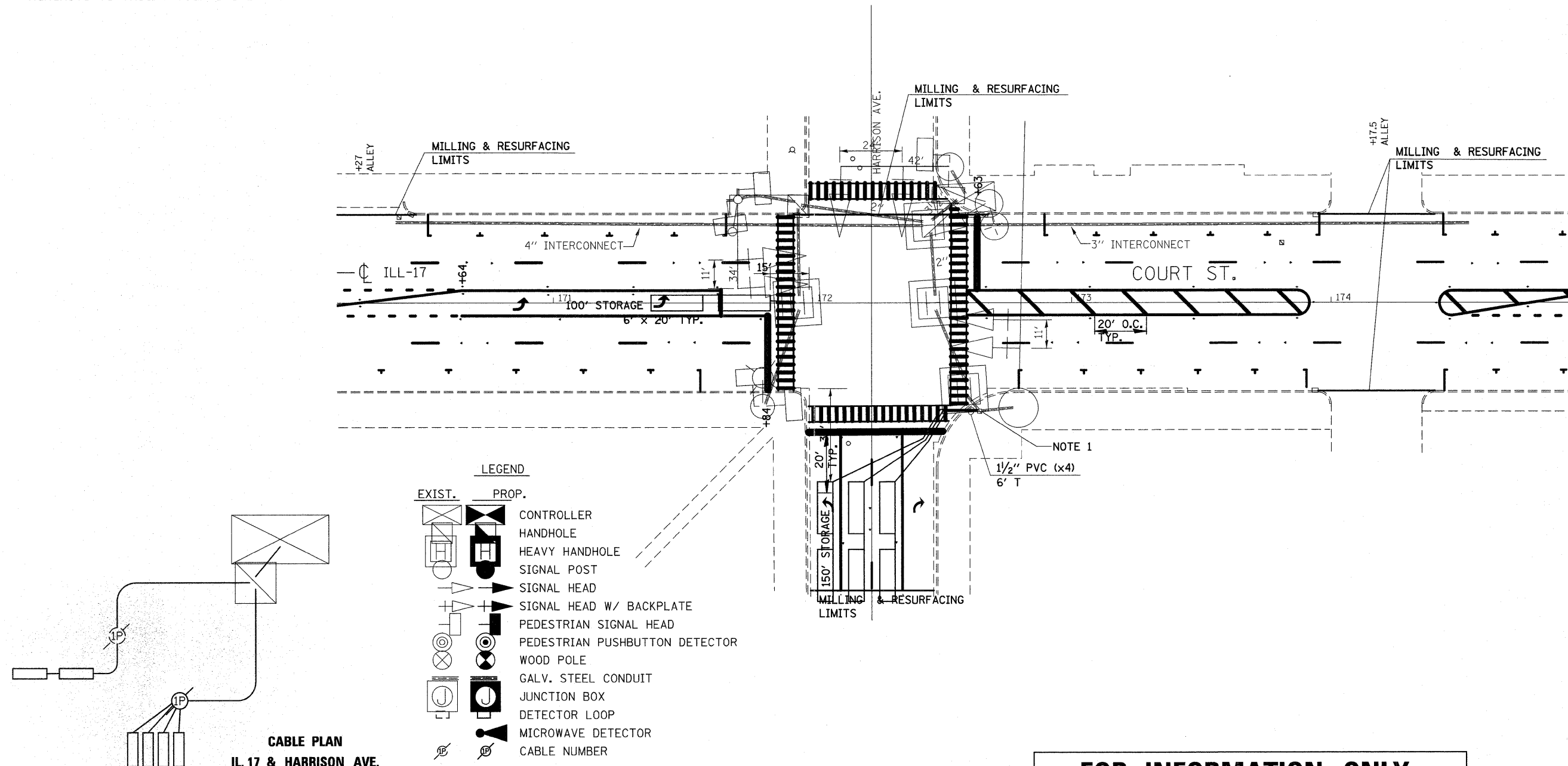

**FOR INFORMATION ONLY**

FILE NAME =	USER NAME = leaf_jw	DESIGNED -	REVISED -	<b>STATE OF ILLINOIS DEPARTMENT OF TRANSPORTATION</b>	<b>IL 17 AND HARRISON AVENUE DETECTOR LOOP INFORMATION</b>	F.A.P. RTE.	SECTION	COUNTY	TOTAL SHEETS	SHEET NO.	
cd:\pw\work\p\dot\q\g\eyml\d0282391\ED06624-sht-detail.dgn		DRAWN -	REVISED -			330	(1,1R-2)RS	KANKAKEE	54	40	
PLOT SCALE = 50,0000 / 1 in.		CHECKED -	REVISED -			CONTRACT NO. 66477		[ILLINOIS] FED. AID PROJECT			
PLOT DATE = 12/20/2011		DATE -	REVISED -			SCALE:	SHEET NO. OF SHEETS	STA. TO STA.			

TRAFFIC SIGNAL CONSTRUCTION SUMMARY

1. Detector loops on Illinois 17 are existing and will be removed by the milling operation. Replace the detector loops as shown.
2. Existing detector loop lead-in cable shall be tested prior to splicing onto the new detector loop. Existing detector loop lead-in testing good shall be reused. Testing of the existing lead-in cable shall be included in the price for Detector Loop Type I.
3. The northbound and southbound detector loops are new.
4. Install inductive loop detectors, harnesses, and necessary parts to place the new inductive loop detectors in operation.
5. Southeast quadrant: Drill existing handhole to insert two 1-1/2" conduits for the tails of the new detectors.
6. Northwest quadrant: Remove sidewalk as necessary. Intercept the existing conduit with a new handhole. Install new detector loops for southbound traffic.

SCHEDULE OF QUANTITIES		
CONDUIT IN TRENCH, 1 1/2" DIA., PVC	FOOT	28
CONCRETE HANDHOLE	EACH	1
DRILL EXISTING HANDHOLE	EACH	2
INDUCTIVE LOOP DETECTOR (SPECIAL)	EACH	2
DETECTOR LOOP, TYPE I	FOOT	422
TRENCH AND BACKFILL FOR ELECTRICAL WORK	FOOT	28
PORTLAND CEMENT CONCRETE SIDEWALK 4 INCH	SQ FT	24
SIDEWALK REMOVAL	SQ FT	36
ELECTRIC CABLE IN CONDUIT, LEAD-IN, NO. 14 1 PAIR	FOOT	225

DETECTOR LOOP INDUCTANCE CHART IL ROUTE 17 & GREENWOOD AVE					
LOOP SYSTEM	LABEL	NO. OF TURNS	INDUCTANCE (uH)	FREQUENCY Hertz	J PIN STATUS
A	SB	3	368	31830	ON
B	WBLT	3	202	42960	ON
C	NB	3	329	33640	ON
D	EBLT	3	217	41451	ON

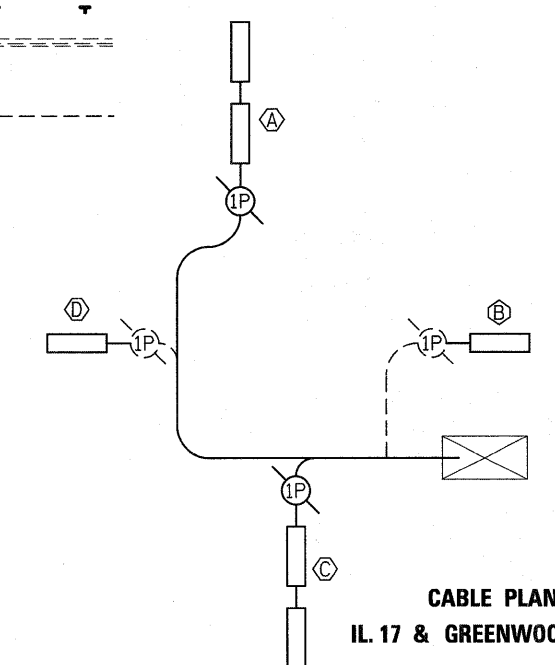
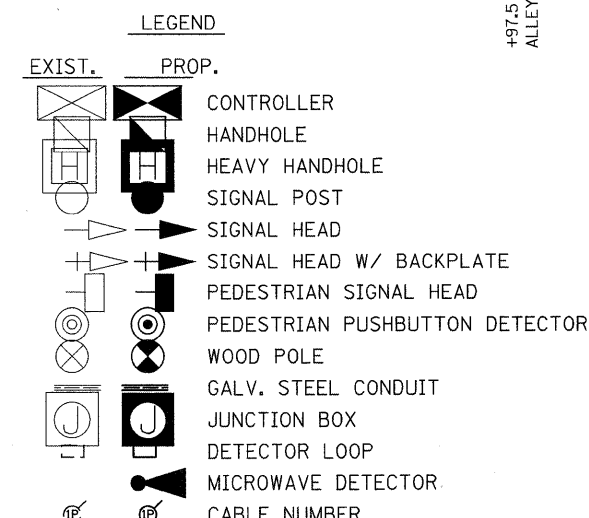
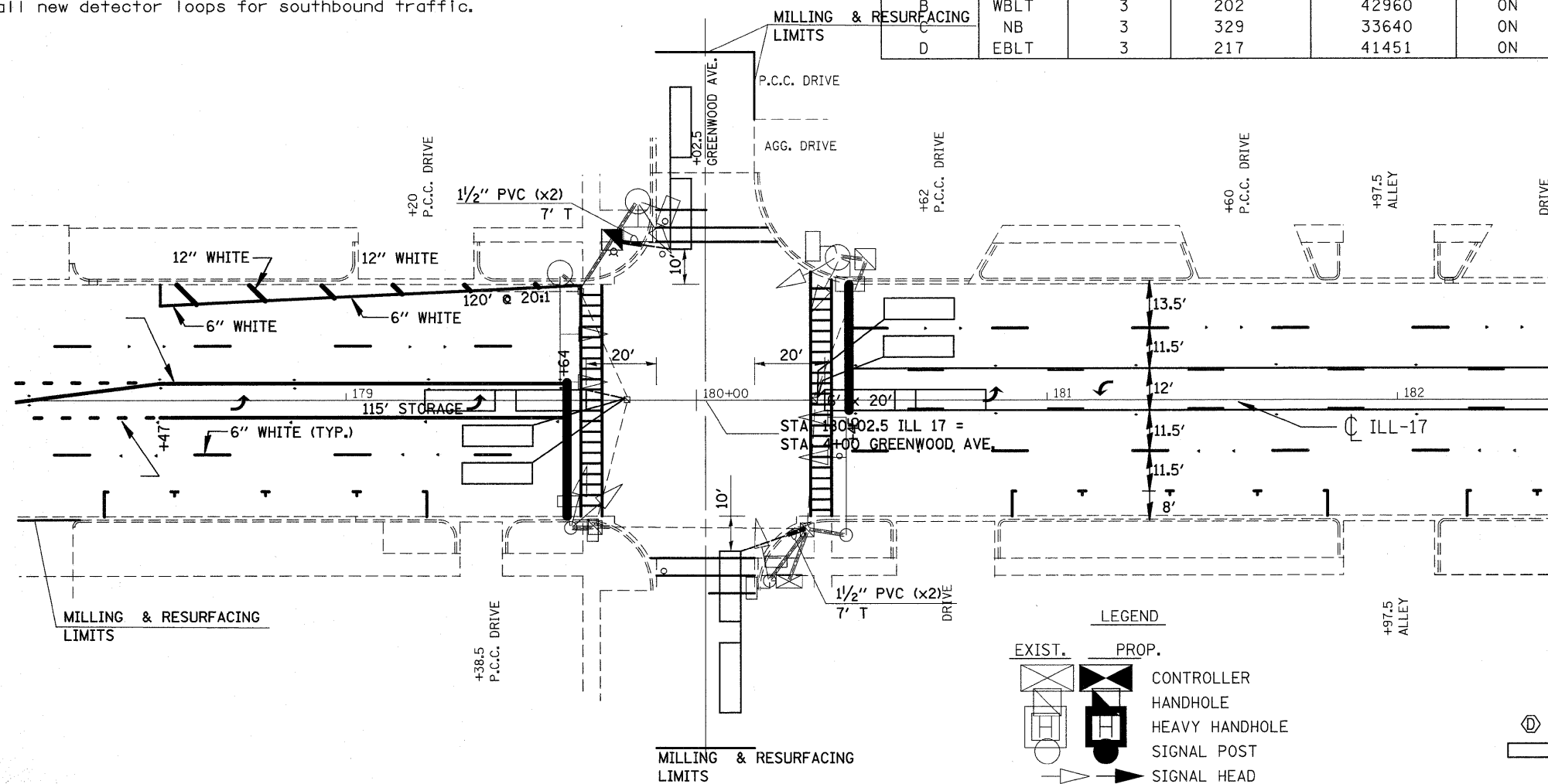

**FOR INFORMATION ONLY**

**CABLE PLAN  
IL 17 & GREENWOOD AVE.**

TRAFFIC SIGNAL CONSTRUCTION SUMMARY

1. Only the far detector loops eastbound and westbound on Illinois 17 will be removed by the milling operation. Replace the detector loops as shown.
2. Existing detector loop lead-in cable shall be tested prior to splicing onto the new detector loop. Existing detector loop lead-in testing good shall be reused. Testing of the existing lead-in cable shall be included in the price for Detector Loop Type I.

SCHEDULE OF QUANTITIES IL ROUTE 17 & HOBBIIE		
DESCRIPTION	UNIT	QUANTITY
DETECTOR LOOP, TYPE I	FOOT	138
DETECTOR TESTING	EACH	1

DETECTOR LOOP INDUCTANCE CHART IL ROUTE 17 & HOBBIIE AVENUE				
LOOP SYSTEM	LABEL	NO. OF TURNS	INDUCTANCE (uH)	FREQUENCY Hertz
A	WB FAR	4	298	35377
B	EB FAR	4	348	32726

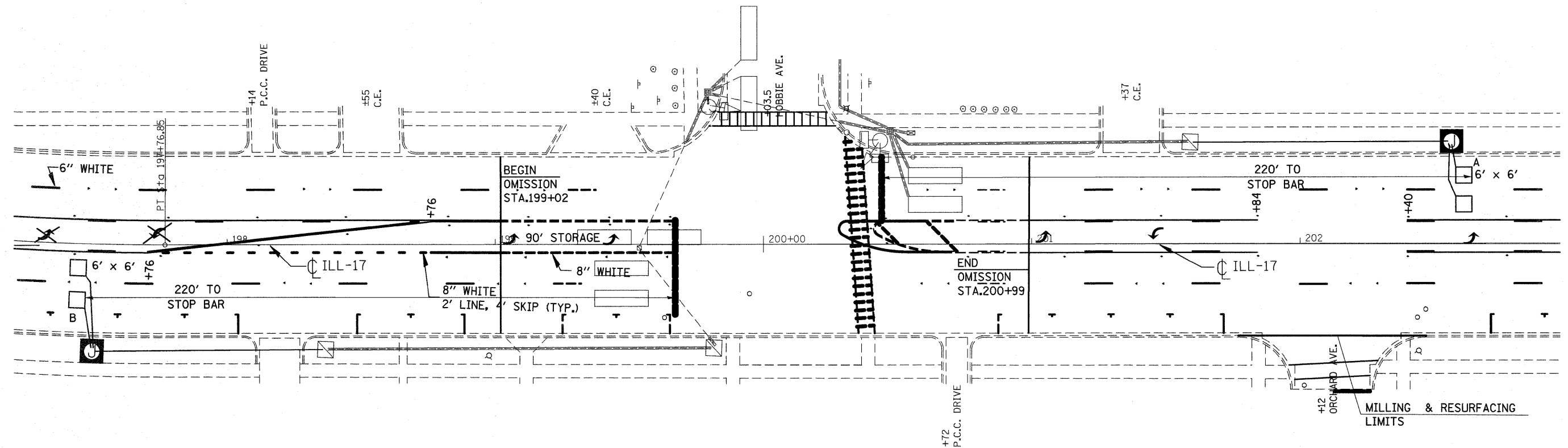

**FOR INFORMATION ONLY**

FILE NAME =	USER NAME = leaf.jw	DESIGNED -	REVISED -	<b>STATE OF ILLINOIS DEPARTMENT OF TRANSPORTATION</b>	<b>IL 17 AND HOBBIIE AVENUE DETECTOR LOOP INFORMATION</b>			F.A.P. RTE.	SECTION	COUNTY	TOTAL SHEETS	SHEET NO.
es:\pw_work\pwwdot\qugleym1\d0282391\ED06684-ahd-detail.dgn		DRAWN -	REVISED -		330	(1,1R-2)RS	KANKAKEE	54	42			
PLOT SCALE = 50,0000' / 1" =		CHECKED -	REVISED -		CONTRACT NO. 66477							
PLOT DATE = 12/28/2011		DATE -	REVISED -		ILLINOIS FED. AID PROJECT							



TRAFFIC SIGNAL CONSTRUCTION SUMMARY

1. Only the detector loops on Illinois 17 will be removed by the milling operation. Replace the detector loops as shown.

2. Existing detector loop lead-in cable shall be tested prior to splicing onto the new detector loop. Existing detector loop lead-in testing good shall be reused. Testing of the existing lead-in cable shall be included in the price for Detector Loop Type I.

3. The contractor shall perform detector testing on the existing loops remaining at this intersection to confirm they remain intact. Damaged loops may be replaced at the direction of the resident.

DETECTOR LOOP INDUCTANCE CHART IL ROUTE 17 & NELSON				
LOOP SYSTEM	LABEL	NO. OF TURNS	INDUCTANCE (uH)	FREQUENCY Hertz
A	WB ST BR	3	375	31502
B	WBLT	3	381	31274
C	WB FAR	4	354	32430
D	NBRL	3	*	*
E	NBLL	3	*	*
F	EB ST BR	3	347	32755
G	EB FAR	4	308	34803

SCHEDULE OF QUANTITIES IL ROUTE 17 & NELSON		
DETECTOR LOOP, TYPE I	FOOT	587
DETECTOR TESTING	EACH	1

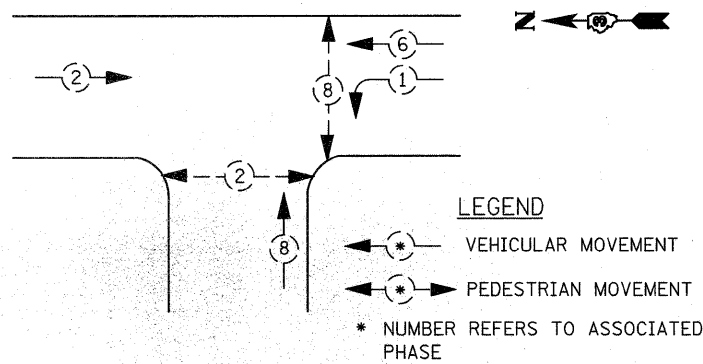
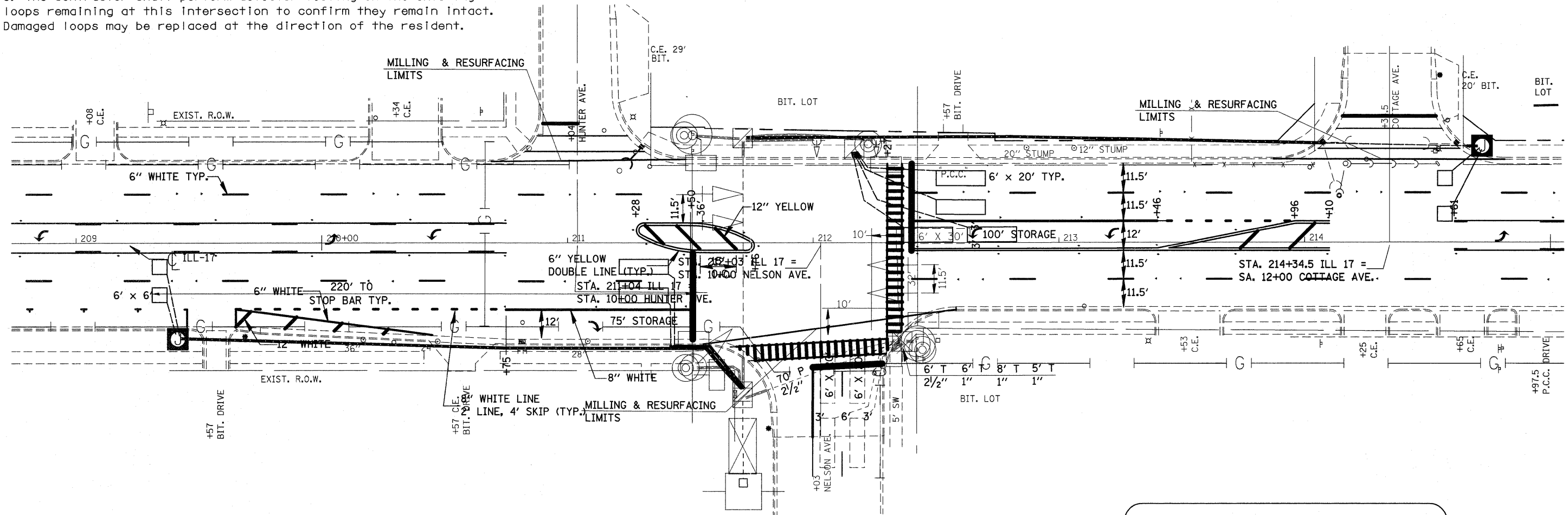

PROPOSED  
PHASE DESIGNATION DIAGRAM  
IL. 17 & NELSON AVENUE

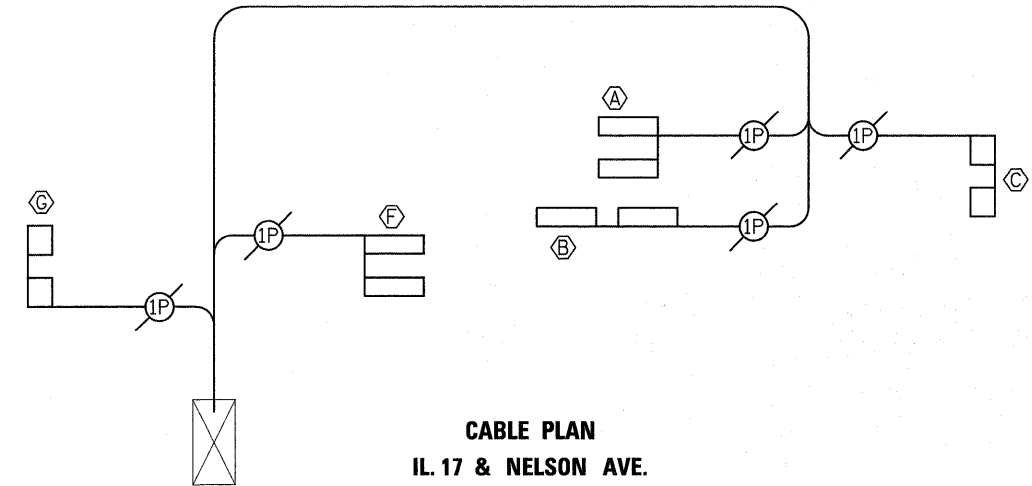
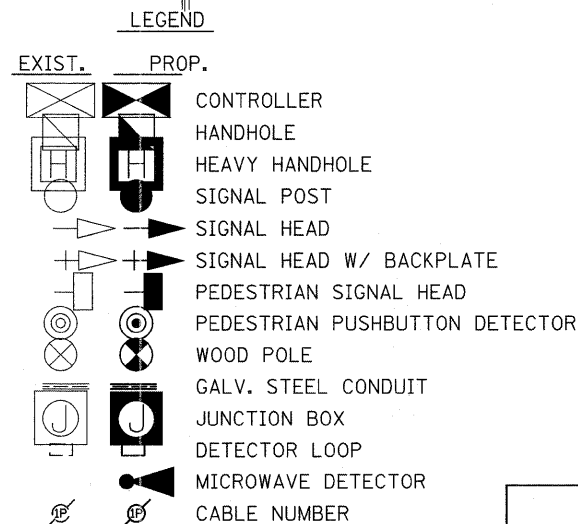

CABLE PLAN  
IL. 17 & NELSON AVE.

**FOR INFORMATION ONLY**

FILE NAME =	USER NAME = leaf_w	DESIGNED -	REVISED -
c:\pwork\psidot\quigley\m\2022391\ED06604-shr-details.dgn		DRAWN -	REVISED -
		CHECKED -	REVISED -
		DATE -	REVISED -

STATE OF ILLINOIS  
DEPARTMENT OF TRANSPORTATION

IL 17 AND NELSON AVENUE  
DETECTOR LOOP INFORMATION

F.A.P. RTE.	SECTION	COUNTY	TOTAL SHEETS	SHEET NO.
330	(1,1R-2)RS	KANKAKEE	54	43
CONTRACT NO. 66477				
ILLINOIS FED. AID PROJECT				

SCALE: SHEET NO. OF SHEETS STA. TO STA.

TRAFFIC SIGNAL CONSTRUCTION SUMMARY

1. Detector loops on Illinois 17 are existing and will be removed by the milling operation. Replace the detector loops as shown.
2. Existing detector loop lead-in cable shall be tested prior to splicing onto the new detector loop. Existing detector loop lead-in testing good shall be reused. Existing detector loop cable testing bad shall be removed and replaced with new only after test measurements have been verified in the presence of the resident. Testing of the existing detector loop and lead-in cable shall be included in the price for Detector Loop Type I.
3. The contractor shall perform detector testing on the existing loops remaining at this intersection to confirm they remain intact. Damaged loops may be replaced at the direction of the resident.
4. The northbound and southbound detector loops will remain.
5. All conduits shown are existing.

SCHEDULE OF QUANTITIES		
DETECTOR LOOP, TYPE I	FOOT	863
DETECTOR TESTING	EACH	1

DETECTOR LOOP INDUCTANCE CHART IL ROUTE 17 & FAIRMONT AVE				
LOOP SYSTEM	LABEL	NO. OF TURNS	INDUCTANCE (uH)	FREQUENCY Hertz
A	SB	3	*	*
B	SBLT	3	*	*
C	EB FAR	4	329	33643
D	EBLT	3	414	30009
E	EB ST BR LL	3	192	44063
F	EB ST BR RL	3	189	44369
G	WB FAR	4	353	32471
H	WB ST BR RL	3	188	44525
I	WB ST BR LL	3	190	44292
J	WBLT	3	416	29914
K	NB	3	*	*

**FOR INFORMATION ONLY**

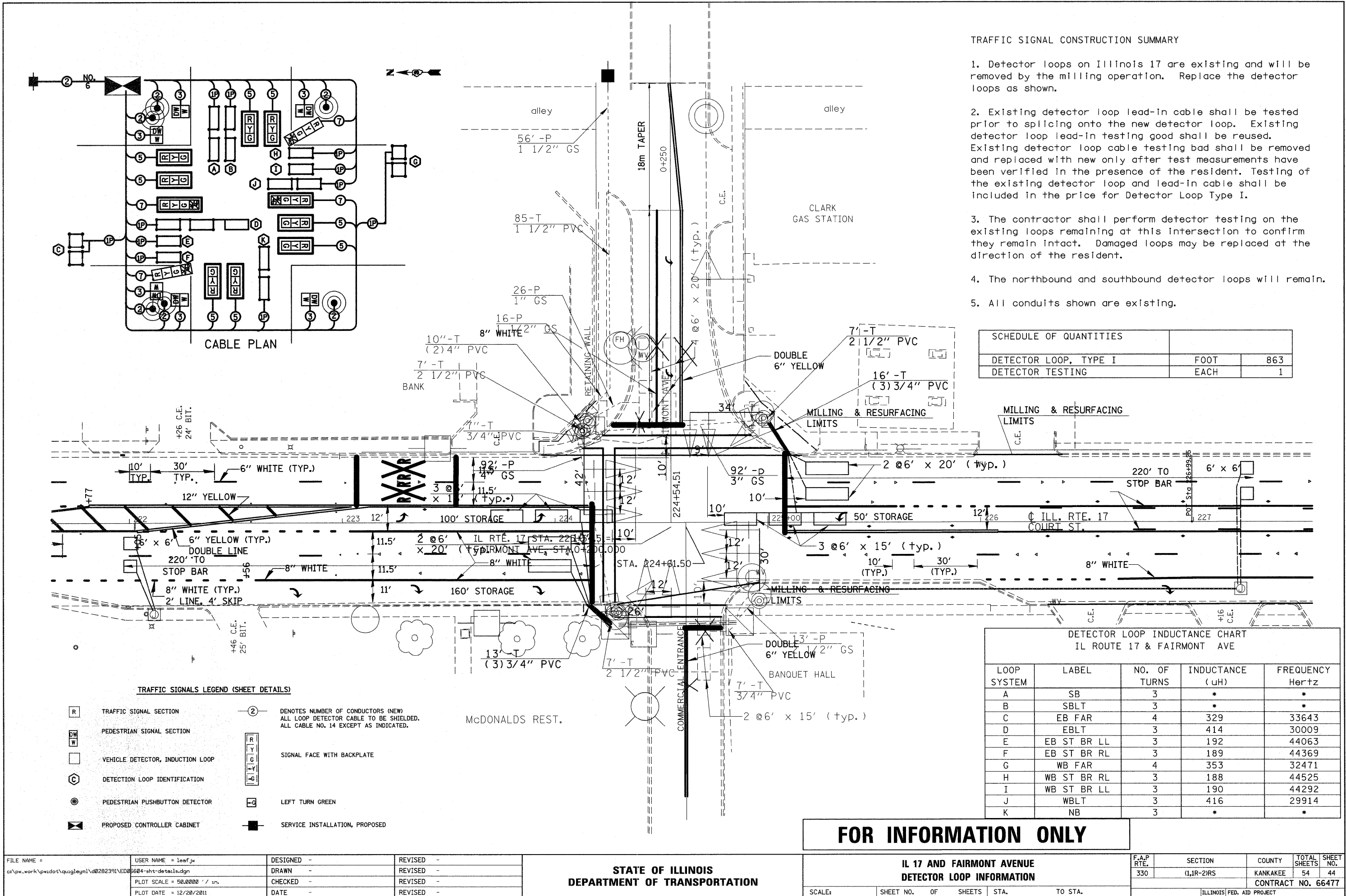

TRAFFIC SIGNALS LEGEND (SHEET DETAILS)

- TRAFFIC SIGNAL SECTION
- PEDESTRIAN SIGNAL SECTION
- VEHICLE DETECTOR, INDUCTION LOOP
- DETECTION LOOP IDENTIFICATION
- PEDESTRIAN PUSHBUTTON DETECTOR
- PROPOSED CONTROLLER CABINET
- DENOTES NUMBER OF CONDUCTORS (NEW)  
ALL LOOP DETECTOR CABLE TO BE SHIELDED.  
ALL CABLE NO. 14 EXCEPT AS INDICATED.
- SIGNAL FACE WITH BACKPLATE
- LEFT TURN GREEN
- SERVICE INSTALLATION, PROPOSED

STATE OF ILLINOIS  
DEPARTMENT OF TRANSPORTATION

IL 17 AND FAIRMONT AVENUE  
DETECTOR LOOP INFORMATION

FILE NAME =	USER NAME = leaf_jw	DESIGNED -	REVISED -	SCALE: SHEET NO. OF SHEETS STA. TO STA.	F.A.P. RTE. 330 SECTION (I,IR-2)RS COUNTY KANKAKEE TOTAL SHEETS 54 SHEET NO. 44 CONTRACT NO. 66477 [ILLINOIS] FED. AID PROJECT
ca:\pw_work\pwwdot\quigley\m\09282391\ED06604-shd-details.dgn	DRAWN -	REVISED -	REVISED -		
PLOT SCALE = 50.0000' / 1"	CHECKED -	REVISED -	REVISED -		
PLOT DATE = 12/20/2011	DATE -	REVISED -	REVISED -		

TRAFFIC SIGNAL CONSTRUCTION SUMMARY

1. Detector loops on Illinois 17 will be removed by the milling operation. Replace the detector loops as shown.

2. Existing detector loop lead-in cable shall be tested prior to splicing onto the new detector loop. Existing detector loop lead-in testing good shall be reused. Existing detector loop cable testing bad shall be removed and replaced with new only after test measurements have been verified in the presence of the resident. Testing of the existing lead-in cable shall be included in the price for Detector Loop Type I.

DETECTOR LOOP INDUCTANCE CHART IL ROUTE 17 & EAST I-57				
LOOP SYSTEM	LABEL	NO. OF TURNS	INDUCTANCE (uH)	FREQUENCY Hertz
A	WB ST BR	3	358	32238
B	WB FAR	4	336	33300
C	WBLT	3	366	31907
D	NBRT FT	*	*	*
E	NBRT BK	*	*	*
F	NB	*	*	*
G	EB ST BR	3	325	33833
H	EB FAR	4	293	35681

SCHEDULE OF QUANTITIES		
DETECTOR LOOP, TYPE I	FOOT	568
DETECTOR TESTING	EACH	1

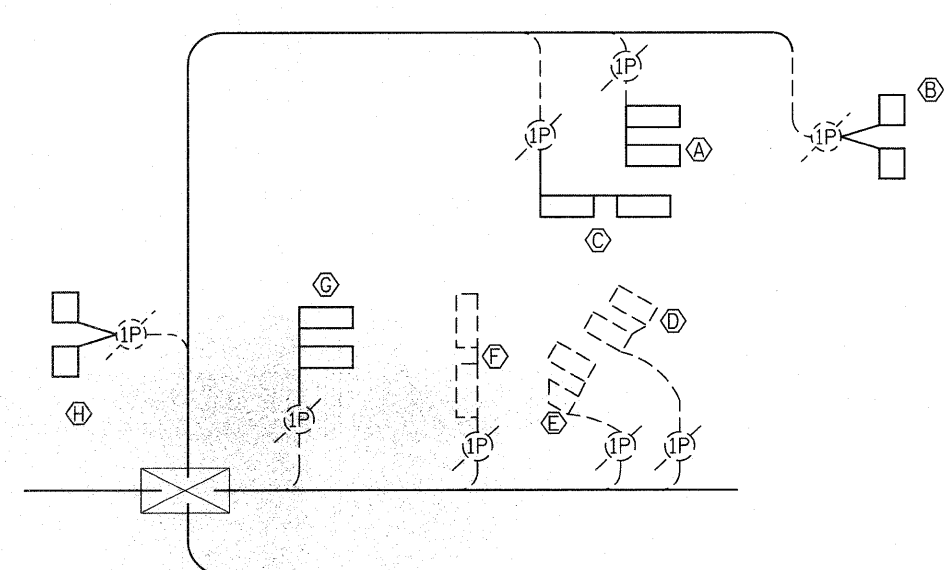
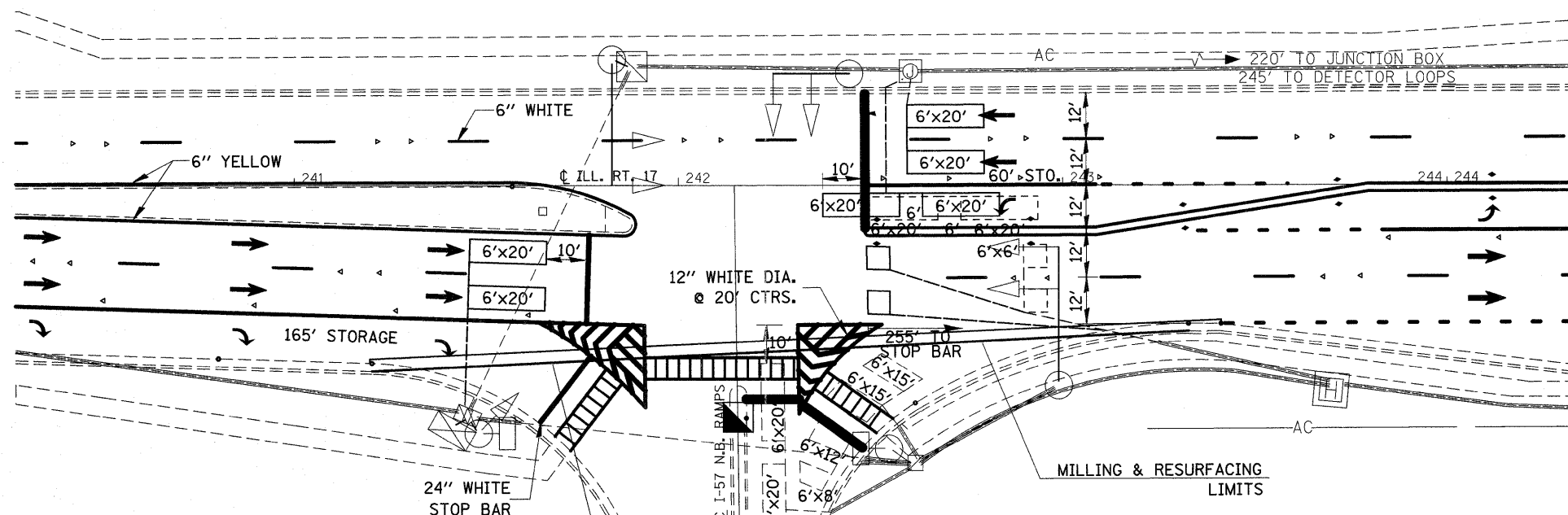

**CABLE PLAN**  
IL 17 & NORTHBOUND RAMP

EXIST.	PROP.	DESCRIPTION
[Symbol]	[Symbol]	CONTROLLER
[Symbol]	[Symbol]	HANDHOLE
[Symbol]	[Symbol]	HEAVY HANDHOLE
[Symbol]	[Symbol]	SIGNAL POST
[Symbol]	[Symbol]	SIGNAL HEAD
[Symbol]	[Symbol]	SIGNAL HEAD W/ BACKPLATE
[Symbol]	[Symbol]	PEDESTRIAN SIGNAL HEAD
[Symbol]	[Symbol]	PEDESTRIAN PUSHBUTTON DETECTOR
[Symbol]	[Symbol]	WOOD POLE
[Symbol]	[Symbol]	GALV. STEEL CONDUIT
[Symbol]	[Symbol]	JUNCTION BOX
[Symbol]	[Symbol]	DETECTOR LOOP
[Symbol]	[Symbol]	MICROWAVE DETECTOR
[Symbol]	[Symbol]	CABLE NUMBER

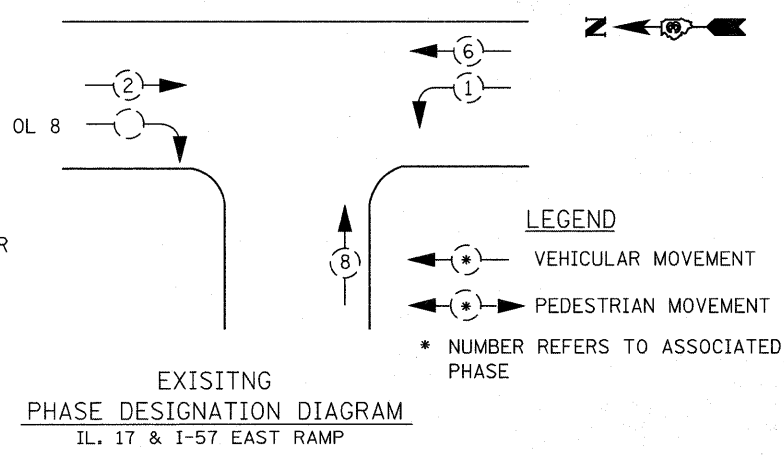

**FOR INFORMATION ONLY**

FILE NAME =	USER NAME = leaf_jw	DESIGNED -	REVISED -	<b>STATE OF ILLINOIS DEPARTMENT OF TRANSPORTATION</b>	<b>IL 17 AND NORTHBOUND RAMPS DETECTOR LOOP INFORMATION</b>			F.A.P. RTE.	SECTION	COUNTY	TOTAL SHEETS	SHEET NO.
cd:\pw_work\pwwork\qutgleym1\00282391\ED006604-ahd-deta1.s.dgn		DRAWN -	REVISED -		330	(1,1R-2)RS	KANKAKEE	54	45			
PLOT SCALE = 50,0000' / 1in.		CHECKED -	REVISED -		CONTRACT NO. 66477							
PLOT DATE = 12/20/2011		DATE -	REVISED -		ILLINOIS FED. AID PROJECT							

DETECTOR LOOP INDUCTANCE CHART  
IL ROUTE 17 & THE WEST I-57 RAMP

LOOP SYSTEM	LABEL	NO. OF TURNS	INDUCTANCE (uH)	FREQUENCY Hertz
A	SBRT FT	3	159	48338
B	SBRT BK	3	227	40470
C	SB	3	502	27238
D	WB ST BR	3	357	32307
E	WB FAR	4	319	34185
F	NB	*	*	*
G	EB ST BR	3	320	34099
H	EB FAR	4	300	35260
I	EBLT BK	3	324	33890
J	EBLT FT	3	168	47074

TRAFFIC SIGNAL CONSTRUCTION SUMMARY

1. Detector loops on Illinois 17 and the southbound offramp are existing and will be removed by the milling operation. Replace the detector loops as shown.
2. Existing detector loop lead-in cable shall be tested prior to splicing onto the new detector loop. Existing detector loop lead-in testing good shall be reused. Testing of the existing lead-in cable shall be included in the price for Detector Loop Type I.
3. The detector tail for the westbound far detector loops passes under the existing concrete median through an existing conduit.

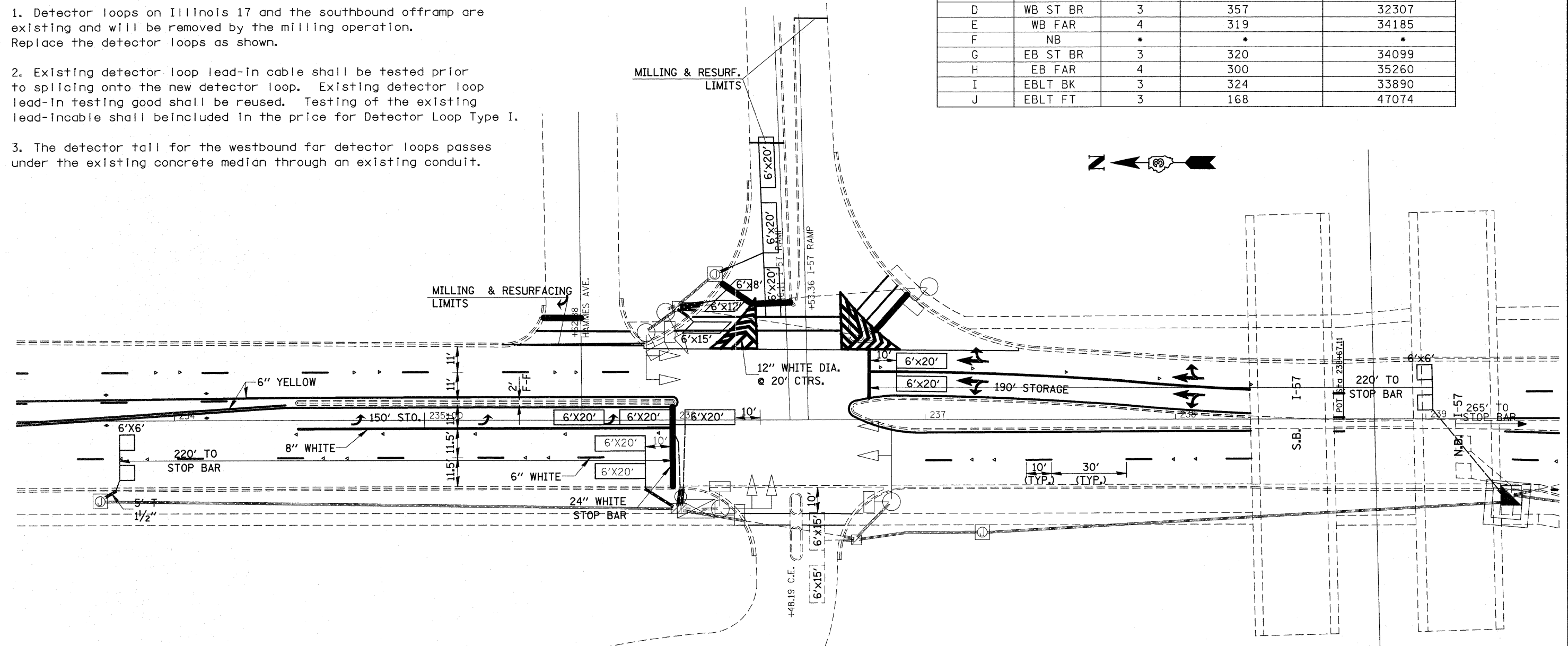

SCHEDULE OF QUANTITIES		
DETECTOR LOOP, TYPE I	FOOT	937
DETECTOR TESTING	EACH	1

**FOR INFORMATION ONLY**

FILE NAME =	USER NAME = leaf.jw	DESIGNED -	REVISED -	<b>STATE OF ILLINOIS DEPARTMENT OF TRANSPORTATION</b>	<b>IL 17 AND SOUTHBOUND RAMPS DETECTOR LOOP INFORMATION</b>	F.A.P. RTE.	SECTION	COUNTY	TOTAL SHEETS	SHEET NO.	
ct:\pwork\pwork\qangleym\1d0282391\ED06604-sht-details.dgn	PLOT SCALE = 50.0000' / 1".	DRAWN -	REVISED -			330	(1,1R-2)RS	KANKAKEE	54	46	
PLOT DATE = 12/28/2011	DATE -	CHECKED -	REVISED -			CONTRACT NO. 66477		ILLINOIS FED. AID PROJECT			
						SCALE:	SHEET NO. OF SHEETS	STA. TO STA.			

SCHEDULE OF QUANTITIES		
DETECTOR LOOP, TYPE I	FOOT	1609
REMOVE ELECTRIC CABLE FROM CONDUIT	FOOT	254

DETECTOR LOOP INDUCTANCE CHART IL ROUTE 17 & EASTRIDGE				
LOOP SYSTEM	LABEL	NO. OF TURNS	INDUCTANCE (uH)	FREQUENCY Hertz
A	SBRT	3	186	44708
B	SBRL	3	354	32448
C	SBLL	3	359	32208
D	WB ST BR	3	328	33708
E	WBLT	3	394	30737
F	WB FAR	4	333	33465
G	NBRL	3	335	33330
H	NBLL FT	3	345	32869
I	NBLL BK	3	288	35959
J	EB ST BR	3	373	31595
K	EBLT	3	368	31802
L	EB FAR	4	386	31062

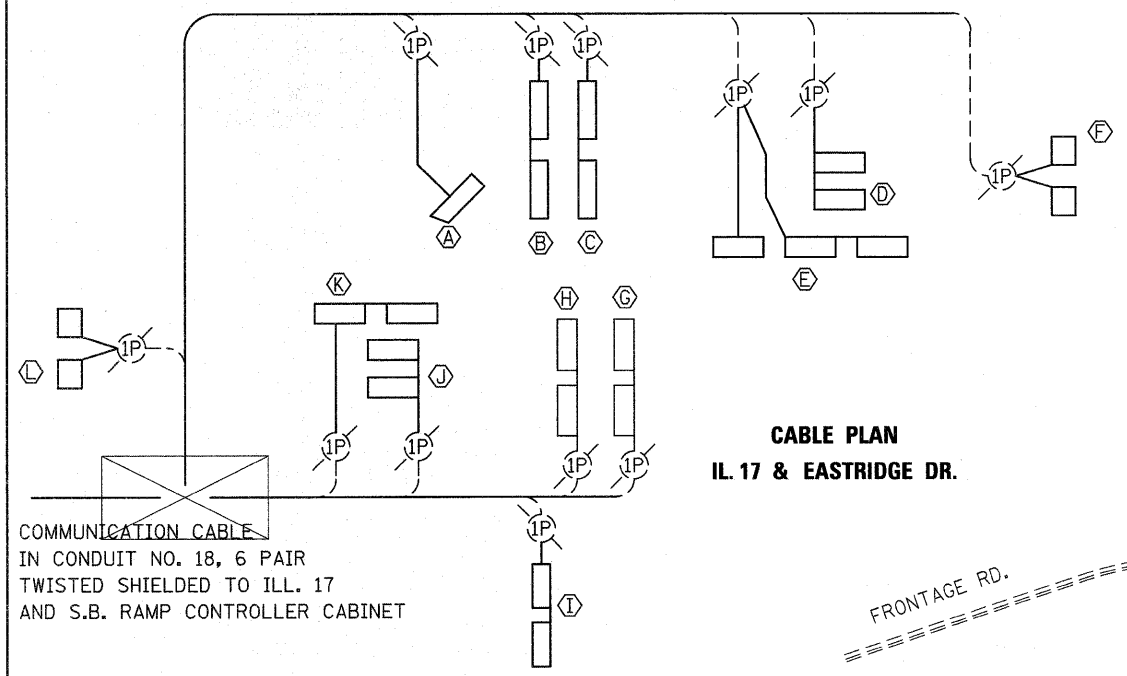

**CABLE PLAN  
IL 17 & EASTRIDGE DR.**

COMMUNICATION CABLE  
IN CONDUIT NO. 18, 6 PAIR  
TWISTED SHIELDED TO ILL. 17  
AND S.B. RAMP CONTROLLER CABINET

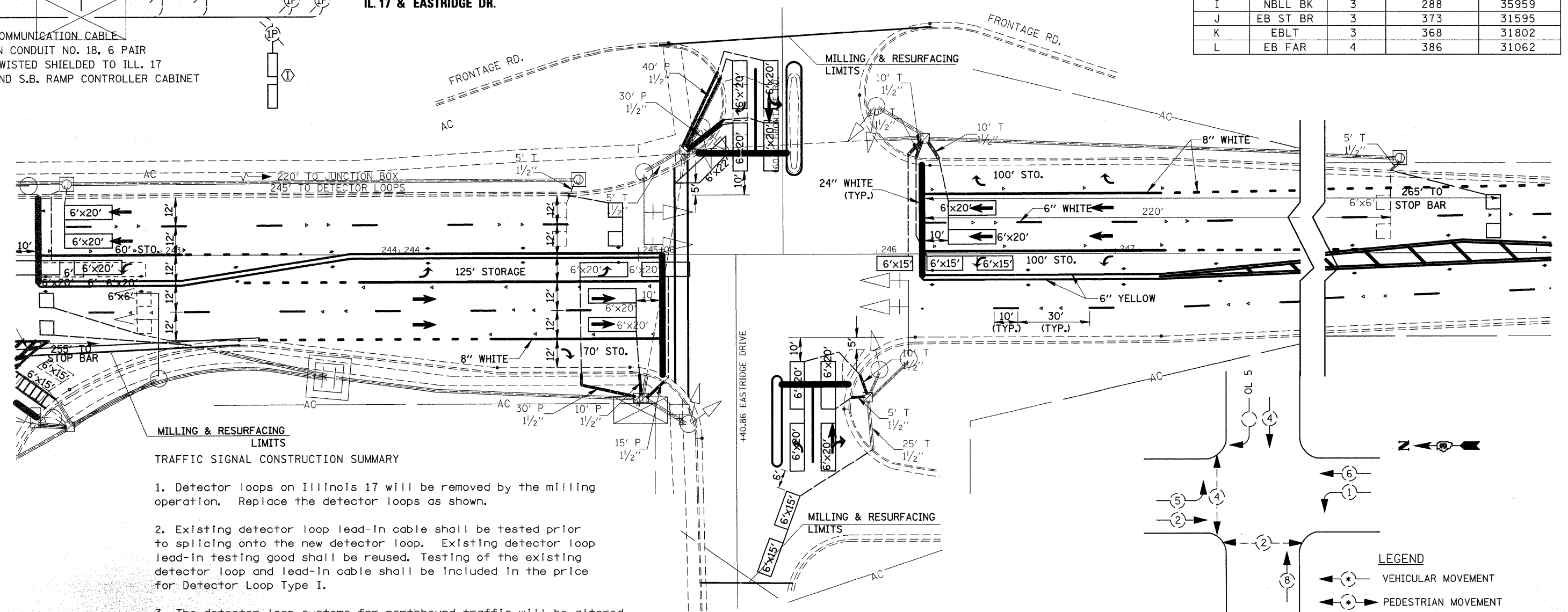

**MILLING & RESURFACING LIMITS**

**TRAFFIC SIGNAL CONSTRUCTION SUMMARY**

1. Detector loops on Illinois 17 will be removed by the milling operation. Replace the detector loops as shown.
2. Existing detector loop lead-in cable shall be tested prior to splicing onto the new detector loop. Existing detector loop lead-in testing good shall be reused. Testing of the existing detector loop and lead-in cable shall be included in the price for Detector Loop Type I.
3. The detector loop systems for northbound traffic will be altered. The amplifier used for the northbound right turn loop will be the detector for the northbound left lane back detector loop.
4. All conduits are existing.
5. An extra lead-in cable will be present for the eastbound left turn and westbound left turn detectors. Remove those two cables, one for the eastbound left turn detector and one for the westbound left turn detector, from the handhole to the controller.

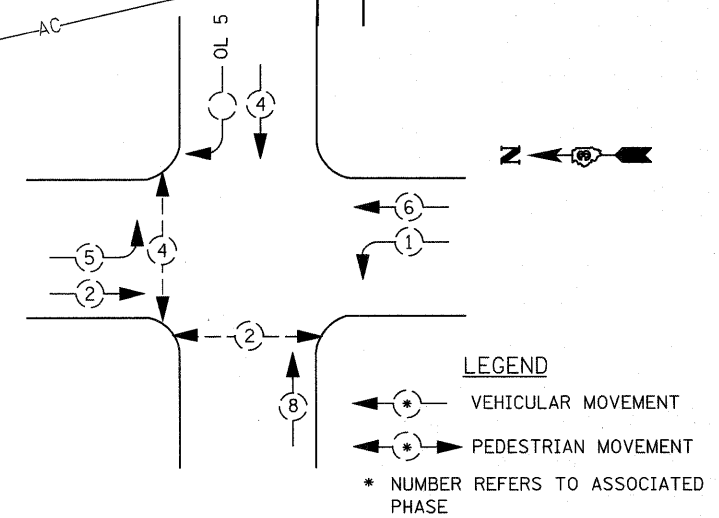

**EXISTING  
PHASE DESIGNATION DIAGRAM  
IL 17 & EASTRIDGE DRIVE**

**FOR INFORMATION ONLY**

FILE NAME =	USER NAME = leaf.jw	DESIGNED -	REVISED -	<b>STATE OF ILLINOIS DEPARTMENT OF TRANSPORTATION</b>	<b>IL 17 AND EASTRIDGE DRIVE DETECTOR LOOP INFORMATION</b>			F.A.P. RTE.	SECTION	COUNTY	TOTAL SHEETS	SHEET NO.
cd:\pw\work\pwwdot\quigley\m\0202391\ED06604-shd-details.dgn		DRAWN -	REVISED -					330	(1,1R-2)RS	KANKAKEE	54	47
PLOT SCALE = 50.0000' / 1"		CHECKED -	REVISED -					CONTRACT NO. 66477				
PLOT DATE = 12/20/2011		DATE -	REVISED -					[ILLINOIS] FED. AID PROJECT				

TRAFFIC SIGNAL CONSTRUCTION SUMMARY

1. Detector loops on Illinois 17 will be removed by the milling operation. Replace the detector loops as shown.
2. Existing detector loop lead-in cable shall be tested prior to splicing onto the new detector loop. Existing detector loop lead-in testing good shall be reused. Testing of the existing lead-in cable shall be included in the price for Detector Loop Type I.
3. The contractor shall perform detector testing on the existing loops remaining at this intersection to confirm they remain intact. Damaged loops may be replaced at the direction of the resident.

DETECTOR LOOP INDUCTANCE CHART IL ROUTE 17 & EASTGATE				
LOOP SYSTEM	LABEL	NO. OF TURNS	INDUCTANCE (uH)	FREQUENCY Hertz
A	SBRT	*	*	*
B	SBRL	*	*	*
C	SBLL	*	*	*
D	WB ST BR	3	328	33708
E	WBLT	3	394	30737
F	WB FAR	4	333	33465
G	NBRT	*	*	*
H	NBRL	*	*	*
I	NBLL	*	*	*
J	EB ST BR	3	373	31595
K	EBLT	3	368	31802
L	EB FAR	4	386	31062

SCHEDULE OF QUANTITIES		
DETECTOR LOOP, TYPE I	FOOT	744
DETECTOR TESTING	EACH	1

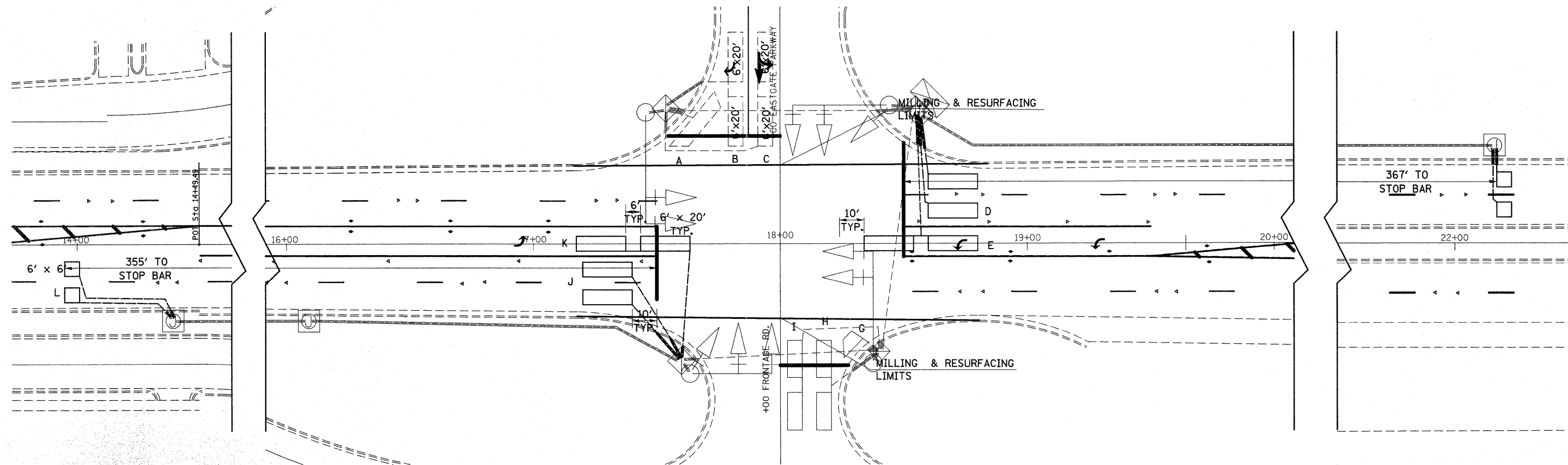
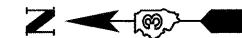

**FOR INFORMATION ONLY**

FILE NAME =	USER NAME = leaf.jw	DESIGNED -	REVISED -
ct:\pw\work\pwt\d0292391\ED066804-sht-details.dgn		DRAWN -	REVISED -
	PLOT SCALE = 50.0000' / 1" =	CHECKED -	REVISED -
	PLOT DATE = 12/20/2011	DATE -	REVISED -

STATE OF ILLINOIS  
DEPARTMENT OF TRANSPORTATION

IL 17 AND EASTGATE PARKWAY  
DETECTOR LOOP INFORMATION

SCALE: SHEET NO. OF SHEETS STA. TO STA.

F.A.P. RTE.	SECTION	COUNTY	TOTAL SHEETS	SHEET NO.
330	(1,1R-2)RS	KANKAKEE	54	48
			CONTRACT NO. 66477	
ILLINOIS FED. AID PROJECT				

**TRAFFIC SIGNALS LEGEND**

EXISTING	PROPOSED	
		SERVICE INSTALLATION
		CONTROLLER CABINET
		METERED SERVICE
		CONDUIT
		EXISTING CONDUIT TO BE USED
		SIGNAL HEAD WITH BACKPLATE
		STEEL MAST ARM WITH POST
		TRAFFIC SIGNAL POST
		HANDHOLE
		DOUBLE HANDHOLE
		DETECTOR LOOP
		LIGHT ON MAST ARM

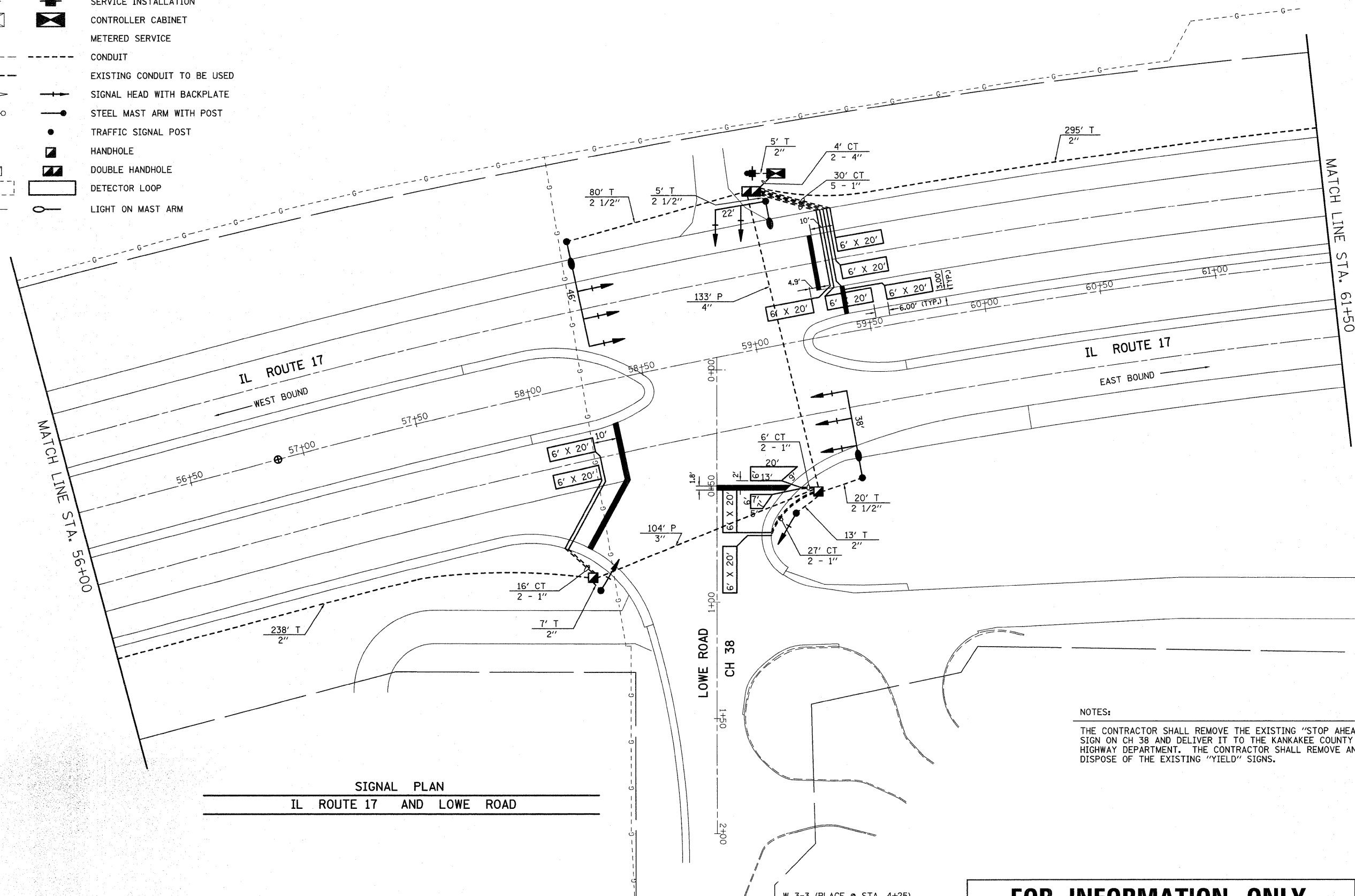

**SIGNAL PLAN**  
IL ROUTE 17 AND LOWE ROAD

**NOTES:**

THE CONTRACTOR SHALL REMOVE THE EXISTING "STOP AHEAD" SIGN ON CH 38 AND DELIVER IT TO THE KANKAKEE COUNTY HIGHWAY DEPARTMENT. THE CONTRACTOR SHALL REMOVE AND DISPOSE OF THE EXISTING "YIELD" SIGNS.

**FOR INFORMATION ONLY**

FILE NAME =  
c:\pw\_work\pwadot\qusgleym\0202391\ED0604-ahd-details.dgn

USER NAME = leaf.jw  
DRAWN -  
CHECKED -  
PLOT SCALE = 50.0000' / 1" =  
PLOT DATE = 12/20/2011

DESIGNED -  
DRAWN -  
CHECKED -  
DATE -

REVISED -  
REVISED -  
REVISED -  
REVISED -

**STATE OF ILLINOIS**  
**DEPARTMENT OF TRANSPORTATION**

**IL 17 AND LOWE ROAD**  
**DETECTOR LOOP INFORMATION**

SCALE: SHEET NO. OF SHEETS STA. TO STA.

F.A.P. RTE.	SECTION	COUNTY	TOTAL SHEETS	SHEET NO.
330	(1,1R-2)RS	KANKAKEE	54	49
CONTRACT NO. 66477				
ILLINOIS FED. AID PROJECT				



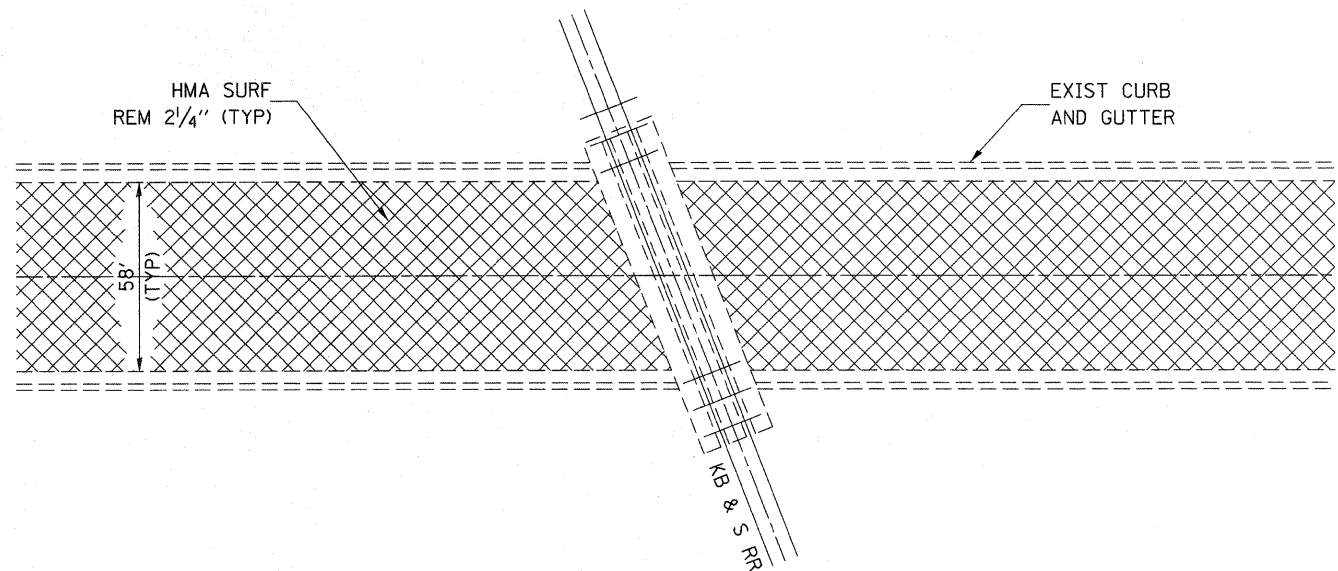

**PLAN VIEW AT THE IL 17 - KB & S  
RAILROAD GRADE CROSSING**  
(DOT/AAR NO. 533 142 N)

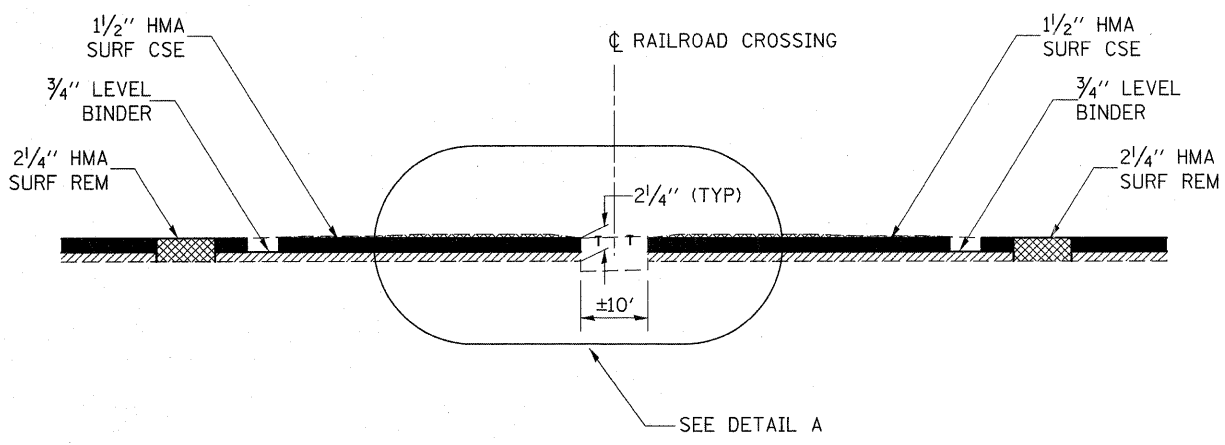

**MILLING DETAIL AT THE IL 17 - KB & S  
RAILROAD GRADE CROSSING**  
(DOT/AAR NO. 533 142 N)

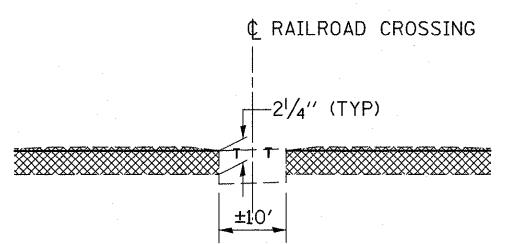

**DETAIL A**

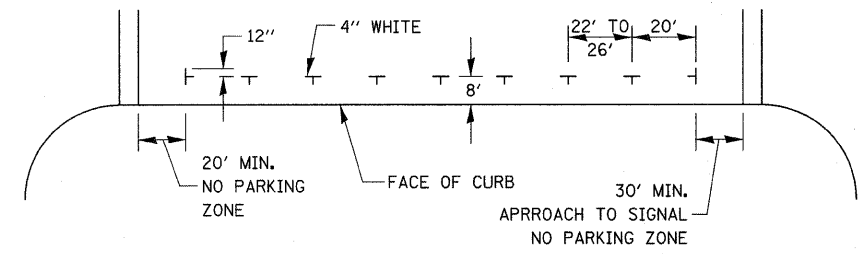

**PREFERRED METHOD**

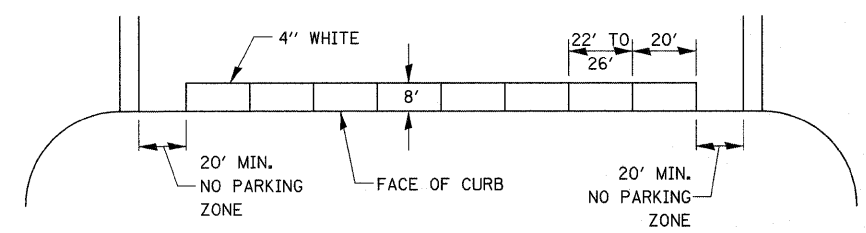

**OPTION 2**

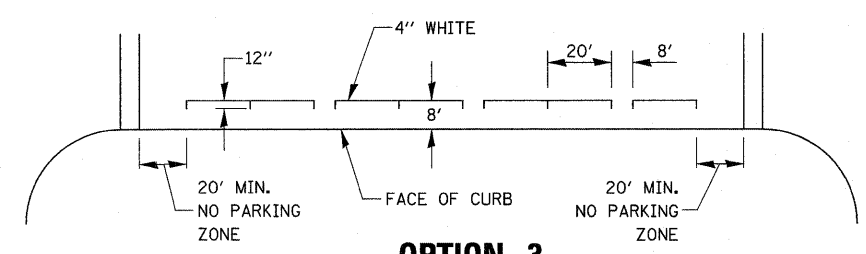

**OPTION 3**

**TYPICAL PARKING SPACING**

FILE NAME =	USER NAME = leef_jw	DESIGNED -	REVISED -	<b>STATE OF ILLINOIS DEPARTMENT OF TRANSPORTATION</b>	<b>DETAILS</b>			F.A.P RTE.	SECTION	COUNTY	TOTAL SHEETS	SHEET NO.			
cd:\pw\work\pwsdot\qunglegm1\0282391\ED086604-sh-t-details.dgn		DRAWN -	REVISED -		SCALE:	SHEET NO.	OF	SHEETS	STA.	TO STA.	330	(1,1R-2)RS	KANKAKEE	54	50
		CHECKED -	REVISED -												
		DATE -	REVISED -												
													ILLINOIS FED. AID PROJECT		





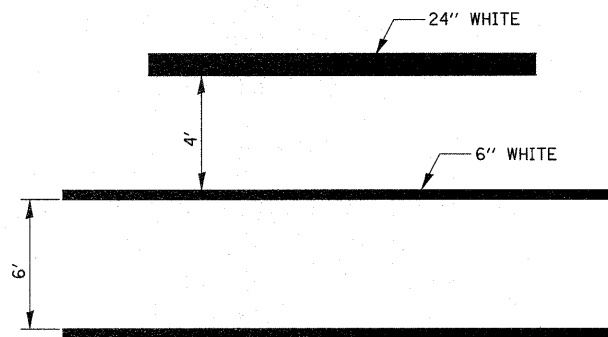

**TYPICAL SPACING DETAIL FOR CROSSWALKS AND STOP BARS**

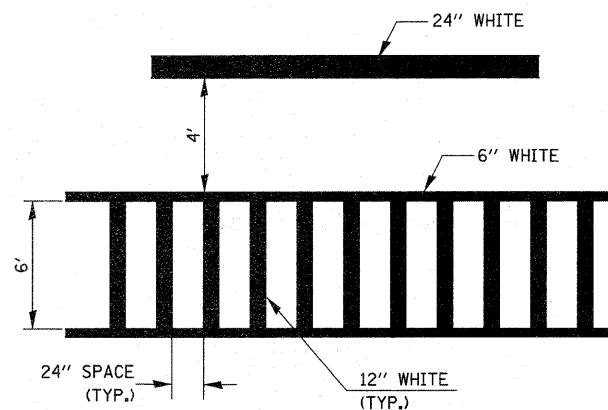

**TYPICAL SPACING DETAIL FOR CROSSWALKS AND STOP BARS**

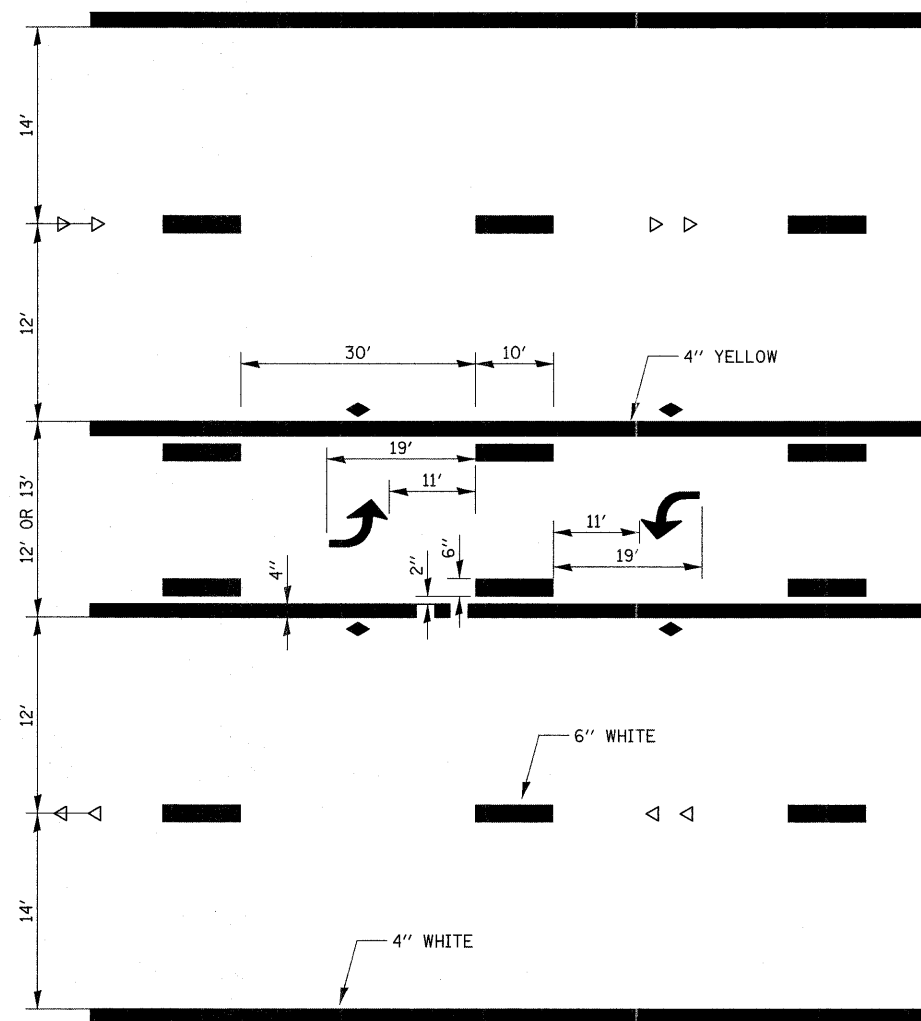

**TYPICAL APPLICATION TWO WAY LEFT TURN LANE (TWLTL)**

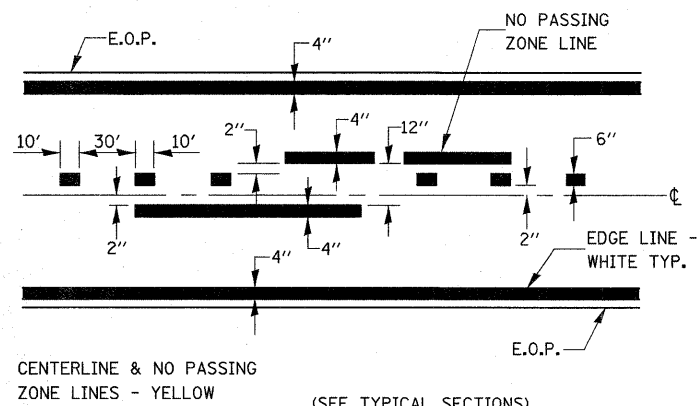

**PAVEMENT MARKING**

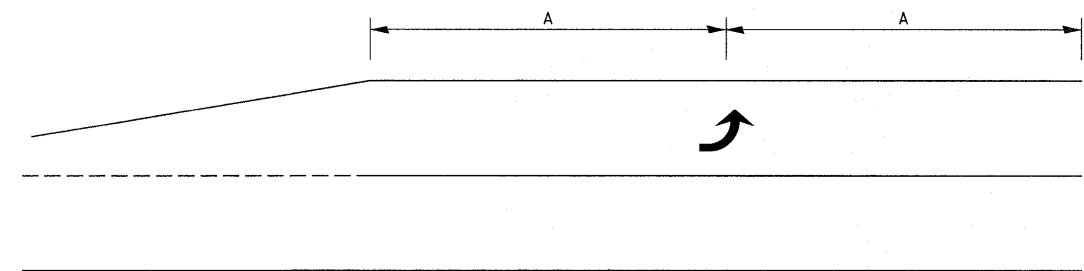

**99' AND UNDER**

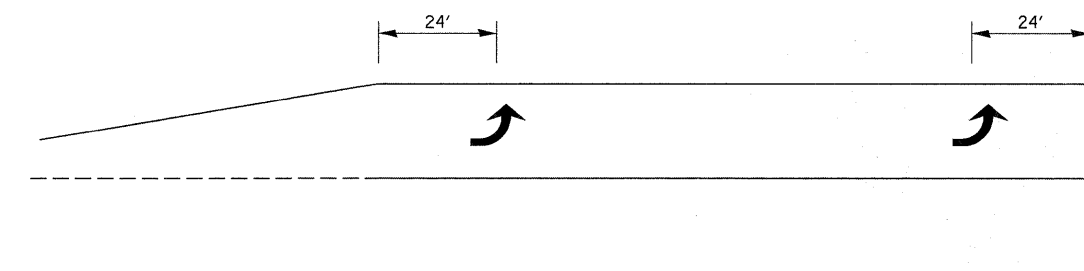

**100' TO 149'**

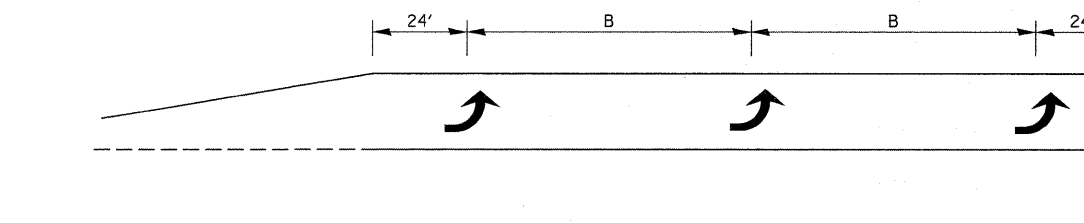

**150' AND LONGER**

**TYPICAL PLACEMENT OF ARROWS IN TURN LANES**

# URBAN PAVEMENT MARKING

FILE NAME =	USER NAME = leof.jw	DESIGNED -	REVISED -	<b>STATE OF ILLINOIS DEPARTMENT OF TRANSPORTATION</b>	<b>DETAILS</b>					F.A.P. RTE.	SECTION	COUNTY	TOTAL SHEETS	SHEET NO.	
cd:\pw_work\pwsdot\qasgleym\02262391\ED06504-sht-details.dgn		DRAWN -	REVISED -		SCALE:	SHEET NO.	OF	SHEETS	STA.	TO STA.	330	(1,1R-2)RS	KANKAKEE	54	53
		CHECKED -	REVISED -		CONTRACT NO. 66477										
		DATE -	REVISED -		ILLINOIS FED. AID PROJECT										

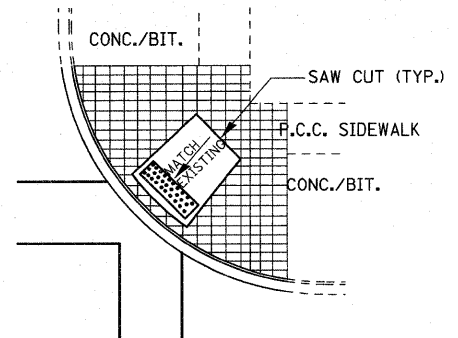

LEGEND	
	PLANTING OR OTHER NON-WALKING SURFACE
	EXISTING BRICK PATTERN TO REMAIN
	DETECTABLE WARNING

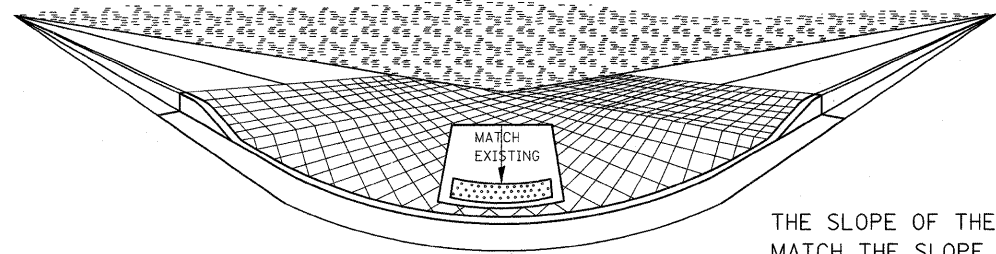

THE SLOPE OF THE ADA RAMP SHALL MATCH THE SLOPE OF THE EXISTING BRICK PATTERN. SIDE FLARES AND CURB WILL ONLY BE NEEDED WHEN EXISTING RAMP DOES NOT MEET STANDARD.

**DIAGONAL CURB RAMP  
PERSPECTIVE WITH DIAGONAL RAMP ADDED**

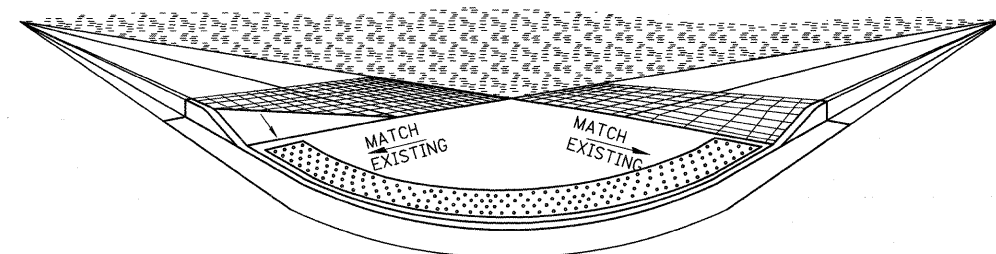
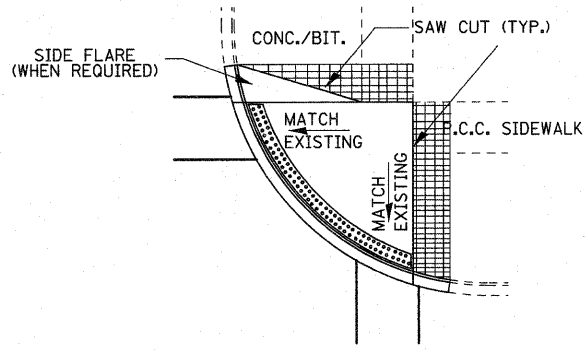

**CORNER PARALLEL RAMPS  
PERSPECTIVE WITH SIDE FLARE(S) IF NEEDED**

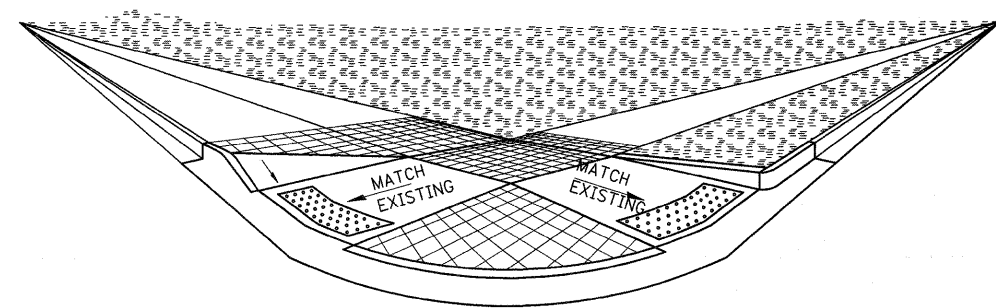
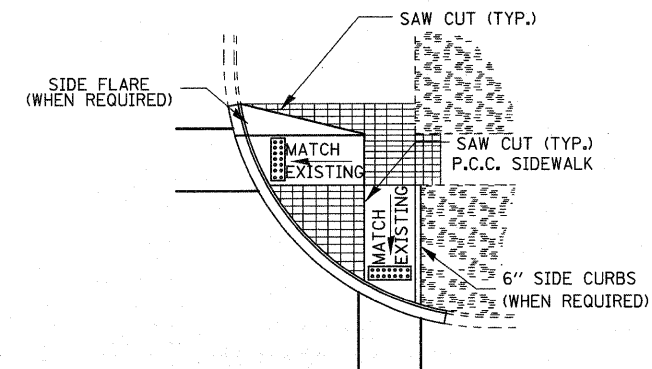

**PERPENDICULAR CURB RAMPS  
PERSPECTIVE WHEN SIDE CURBS AND SIDE FLARES ARE ADDED**

NOTES:  
 THE MAXIMUM SLOPE OF THE SIDE FLARE IS 10:1.  
 THE MAXIMUM LONGITUDINAL SLOPE OF THE RAMP IS 12:1  
 SEE STANDARDS 424001, 424006, AND 424011 FOR DETAILS NOT SHOWN  
 RETROFIT RAMP TO BE A NOMINAL 5' WIDE, 4' MINIMUM IF REQUIRED BY FIELD CONDITIONS  
 THE RAMP SHALL EXTEND FOUR FEET BEYOND THE DETECTABLE WARNING

**PLAN VIEWS**

FILE NAME =	USER NAME = leaf.jw	DESIGNED -	REVISED -	<b>STATE OF ILLINOIS DEPARTMENT OF TRANSPORTATION</b>	<b>DETAILS</b>				F.A.P. RTE.	SECTION	COUNTY	TOTAL SHEETS	SHEET NO.
c:\pw\work\pwwdot\qusgleym1\d0292391\ED06604-ahf-detail.dgn		DRAWN -	REVISED -		330	(1,1R-2)RS	KANKAKEE	54	54				
PLOT SCALE = 50.0000' / 1"		CHECKED -	REVISED -		CONTRACT NO. 66477								
PLOT DATE = 12/20/2011		DATE -	REVISED -		ILLINOIS FED. AID PROJECT								
				SCALE:	SHEET NO.	OF	SHEETS	STA.	TO STA.				