

MILLING TRANSITION DETAIL FROM VAR. DEPTH TO 2 1/4"

STA. 43+99 TO STA. 44+49
STA. 59+90 TO STA. 60+40

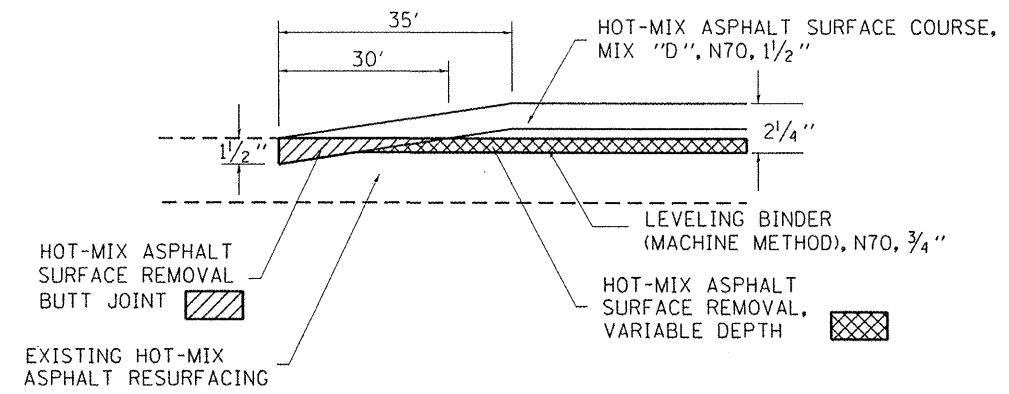

HOT-MIX ASPHALT BUTT JOINT DETAIL

STA. 5+06 TO STA. 5+41

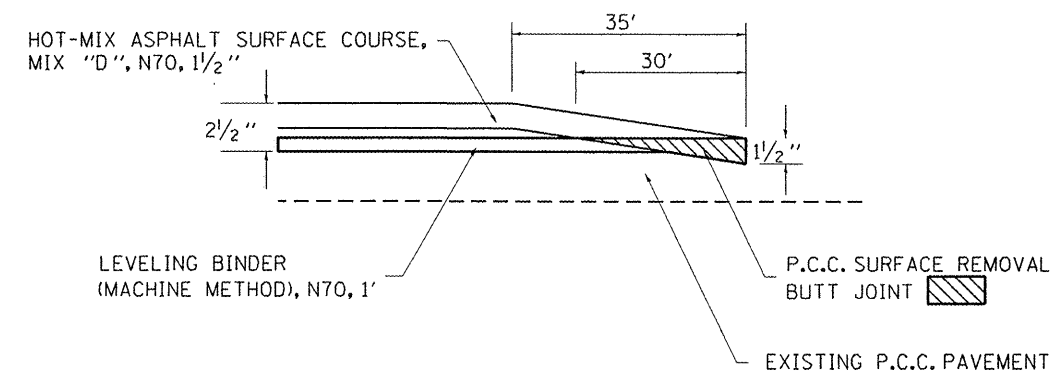

P.C.C. BUTT JOINT DETAIL

STA. 79+50 TP STA. 79+85

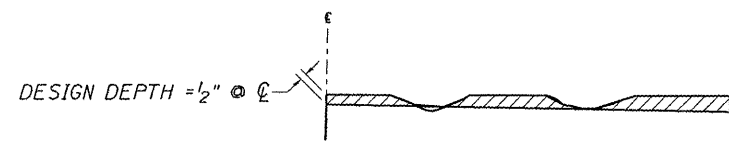

NOTES:

1. MILLING SHALL BE DONE TO ATTAIN A 3/16 "/FT. SLOPE IN CROWN SECTIONS
2. EXISTING S.E. AND S.E. TRANSITIONS SHALL BE MAINTAINED UNLESS OTHERWISE SHOWN ON THE PLANS.
3. MILLING TO THE BOTTOM OF WHEEL RUTS SHALL NOT BE NECESSARY UNLESS REQUIRED TO OBTAIN SLOPE OR THE DESIGN DEPTH AT CENTERLINE.
4. THE AVERAGE DEPTH OF MILLING IS ESTIMATED TO BE 1/2" BUT MAY VARY IN ISOLATED LOCATIONS.

HOT-MIX ASPHALT SURFACE REMOVAL (VARIABLE DEPTH) DETAIL

STA. 5+41 TO STA. 43+99
STA. 60+40 TO STA. 73+78

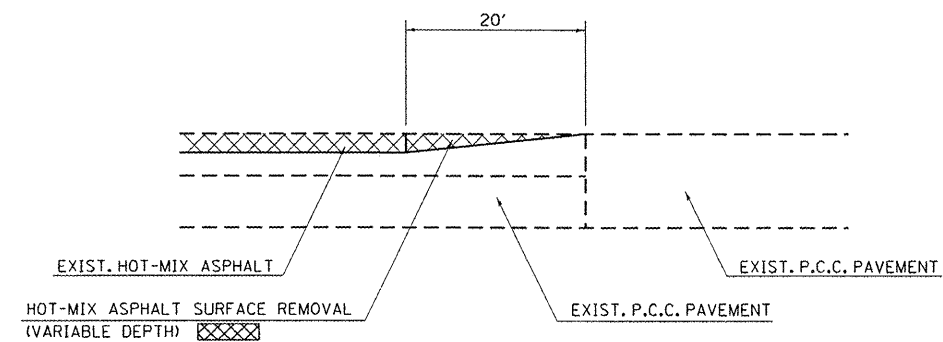

MILLING TRANSITION DETAIL FROM VAR. DEPTH TO 0"

STA. 73+78 TO STA. 73+98

FILE NAME =	USER NAME = administrator	DESIGNED -	REVISED -
ei:\pic_work\puidot\stefanmk\d0270542\ND74533-sht-details.dgn		DRAWN -	REVISED -
		CHECKED -	REVISED -
		DATE -	REVISED -

**STATE OF ILLINOIS
DEPARTMENT OF TRANSPORTATION**

MILLING DETAILS		
SCALE: NA	SHEET NO. 1 OF 1 SHEETS	STA. TO STA.

S.B.I. RTE.	SECTION	COUNTY	TOTAL SHEETS	SHEET NO.
11	D7 HMA RESUR 2012-3	CLARK	11	9
CONTRACT NO. 74533			ILLINOIS FED. AID PROJECT	