

RR OMISSION:
STA. 2582+62 TO STA. 2582+72

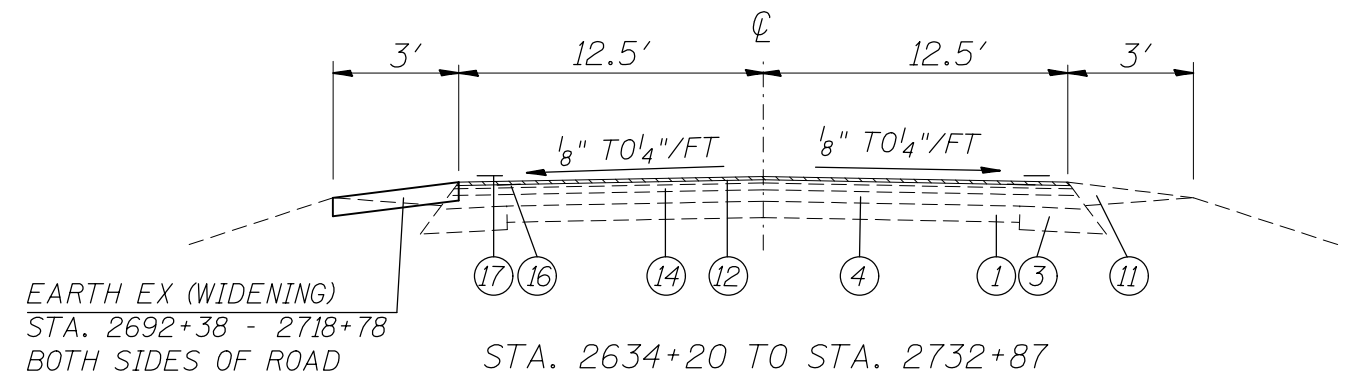
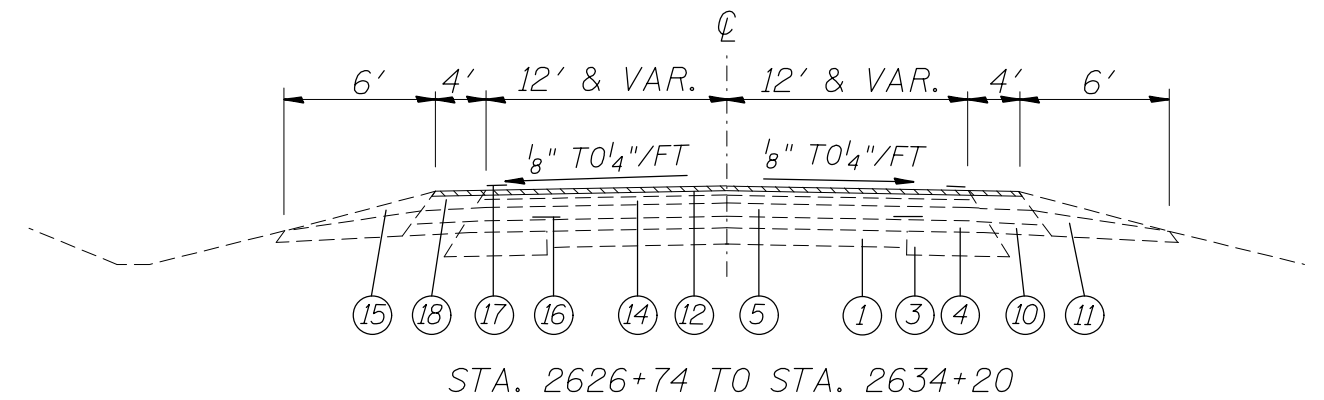
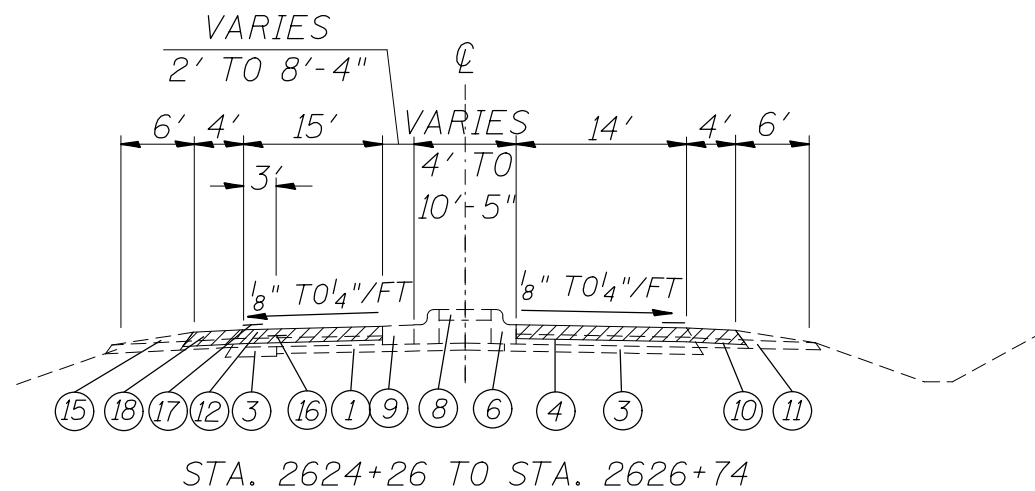
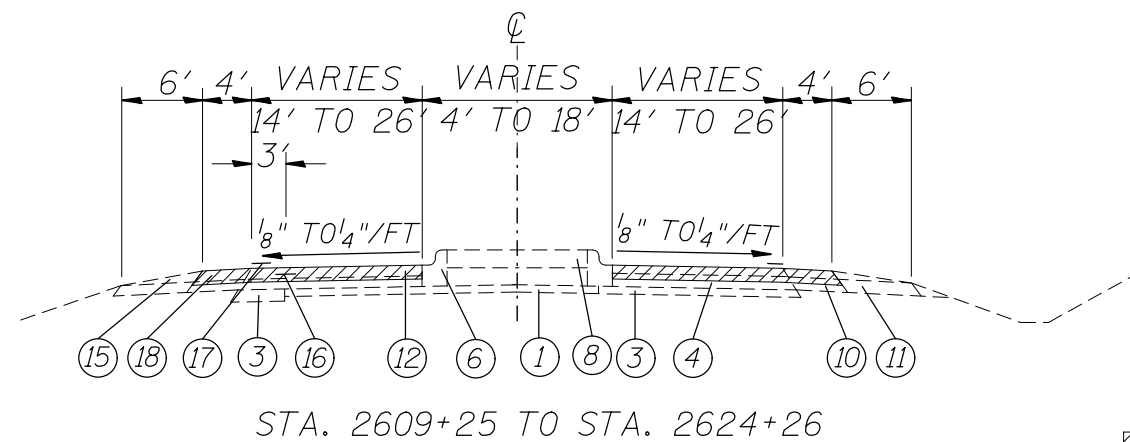

- PROP. HMA SURFACE REMOVAL, 2 1/4"
- PROP. HMA SURFACE REMOVAL, 1/2"

LEGEND

- ① Existing Concrete Pavement
- ② Existing Leveling Binder (Variable)
- ③ Existing Bit. Base Course
- ④ Existing Bit. Surface Course
- ⑤ Existing Bit. Surface Course 1 1/2 "
- ⑥ Existing Comb. Curb & Gutter B-6.24
- ⑦ Existing 4' P.C.C. Sidewalk (4")
- ⑧ Existing 4" P.C.C. Median Surface
- ⑨ Existing Conc. Median Type C-4 Special
- ⑩ Existing Bit. Shoulder
- ⑪ Existing Agg. Shoulder, Type A
- ⑫ Existing HMA Surface Course 1 1/2 "
- ⑬ Existing Leveling Binder (Variable 1/2 "-1")
- ⑭ Existing Leveling Binder 3/4 "
- ⑮ Existing Aggregate Shoulder Wedge, Type B
- ⑯ Existing Strip Reflective Crack Control
- ⑰ Existing White Edgeline Stripe 4" *
- ⑱ Existing HMA Shoulder

FILE NAME =	USER NAME = conoverpj	DESIGNED -	REVISED -
et:\pwork\pwork\conoverpj\d0212697\d876e52-sh1-plan.dgn		DRAWN -	REVISED -
	PLOT SCALE = 100.0000' / 1"	CHECKED -	REVISED -
	PLOT DATE = 12/15/2011	DATE -	REVISED -

**STATE OF ILLINOIS
DEPARTMENT OF TRANSPORTATION**

EXISTING TYPICAL SECTIONS

SCALE: SHEET NO. 1 OF 1 SHEETS STA. TO STA.

F.A.P. RTE.	SECTION	COUNTY	TOTAL SHEETS	SHEET NO.
*322/821	(10-1,11)RS-3	WASHINGTON	18	6
FED. ROAD DIST. NO.	ILLINOIS FED. AID PROJECT	CONTRACT NO. 76E52		