

PETRI LANE PROPOSED TYPICAL SECTION - 3  
STA. 25+00.00 TO STA. 29+17.51

INTERSECTION OMISSION  
STA. 29+17.51 TO 29+91.60

- 5 TEMPORARY EASEMENT  
STA. 24+55.54 TO STA. 26+66.61 = 5'-0"  
STA. 26+66.61 TO STA. 29+17.51 = 20'-0"
- 6 EXISTING ROW (LEFT)  
STA. 24+55.54 TO STA. 26+66.83 = TRANSITION FROM 24'-7" TO 19'-10"  
STA. 26+66.83 TO STA. 26+66.82 = TRANSITION FROM 19'-10" TO 15'-10"  
STA. 26+66.82 TO STA. 29+17.51 = TRANSITION FROM 15'-10" TO 10'-2"
- 7 EXISTING EASEMENT/ROW (RIGHT)  
STA. 24+55.54 TO STA. 26+66.61 = TRANSITION FROM 38'-5" TO 43'-2"  
STA. 26+66.61 TO STA. 26+66.65 = TRANSITION FROM 43'-2" TO 34'-2"  
STA. 26+66.61 TO STA. 29+17.51 = TRANSITION FROM 34'-2" TO 39'-10"

LEGEND

- 1 EXISTING PAVEMENT (TO REMAIN)
- 2 EXISTING CURB AND GUTTER (TO REMAIN)
- 3 PROPOSED AGGREGATE BASE COURSE, TYPE A, 12"
- 4 PROPOSED HOT-MIX ASPHALT SURFACE COURSE, MIX "C", N30, 2"
- 5 PROPOSED HOT-MIX ASPHALT BINDER COURSE, IL-19.0, N30, 4"
- 6 PROPOSED COMBINATION CONCRETE CURB AND GUTTER, TYPE B-6.12
- 7 PROPOSED PORTLAND CEMENT CONCRETE SIDEWALK, 4" WITH AGGREGATE BASE COURSE, TYPE A, 2"
- 8 PROPOSED TOP SOIL FURNISH AND PLACE, 6"
- 9 PROPOSED SEEDING, CLASS 2A

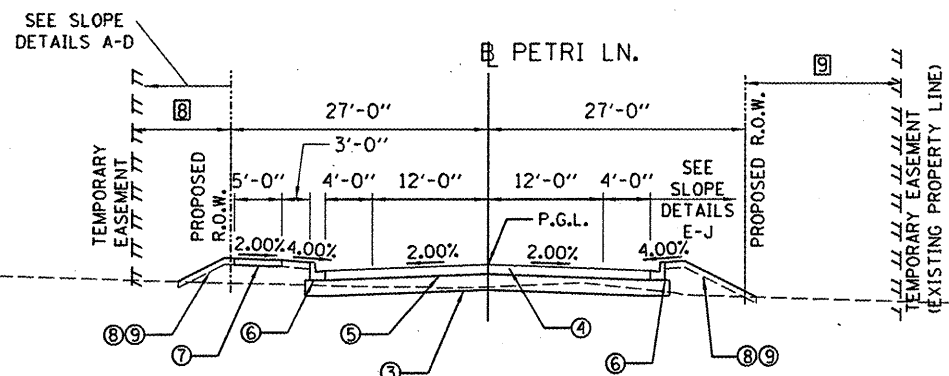
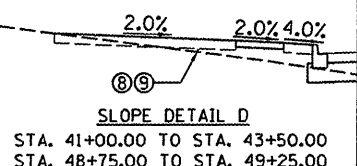
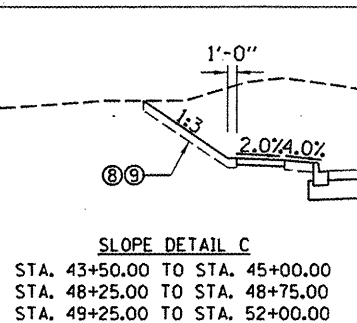
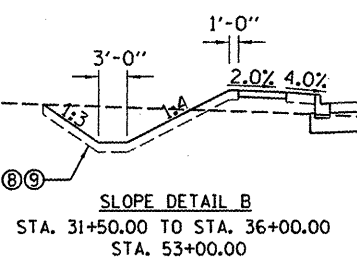
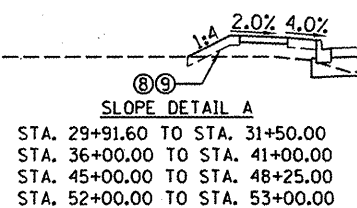

PETRI LANE PROPOSED TYPICAL SECTION - 4  
STA. 29+91.60 TO STA. 53+00.00

- 8 TEMPORARY EASEMENT (LEFT)  
STA. 29+91.60 TO STA. 31+00.00 = 20'-0"  
STA. 31+00.00 = TRANSITION FROM 20'-0" TO 25'-0"  
STA. 31+00.00 TO STA. 42+00.00 = 25'-0"  
STA. 42+00.00 = TRANSITION FROM 25'-0" TO 40'-0"  
STA. 42+00.00 TO STA. 43+50.00 = 40'-0"  
STA. 43+50.00 = TRANSITION FROM 40'-0" TO 15'-0"  
STA. 43+50.00 TO STA. 48+50.00 = 15'-0"  
STA. 48+50.00 = TRANSITION FROM 15'-0" TO 30'-0"  
STA. 48+50.00 TO STA. 53+00.00 = 30'-0"
- 9 TEMPORARY EASEMENT (RIGHT)  
STA. 29+91.60 TO STA. 40+84.20 = TRANSITION FROM 1'-7" TO 26'-8"  
STA. 40+84.20 TO STA. 41+18.66 = TRANSITION FROM 26'-8" TO 30'-0"  
STA. 41+18.66 TO STA. 49+00.00 = 30'-0"  
STA. 49+00.00 = TRANSITION FROM 30'-0" TO 20'-0"  
STA. 49+00.00 TO STA. 53+00.00 = 20'-0"

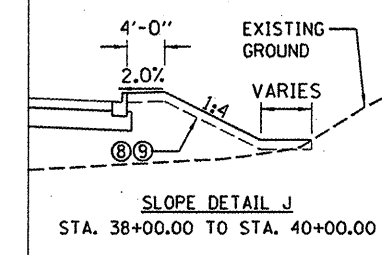
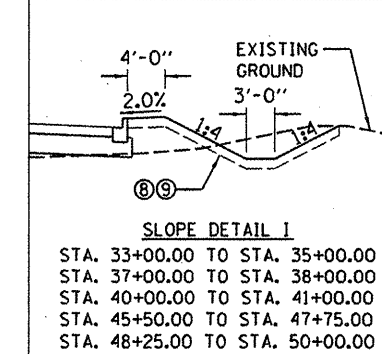
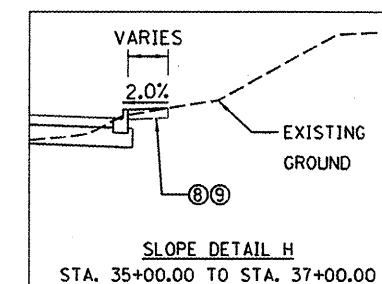
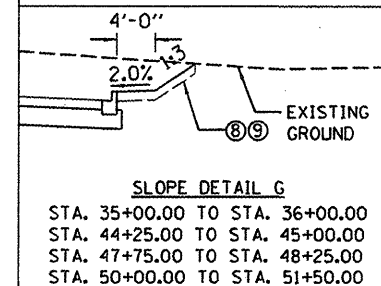
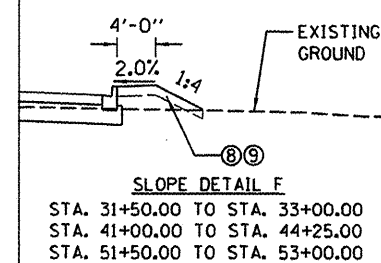
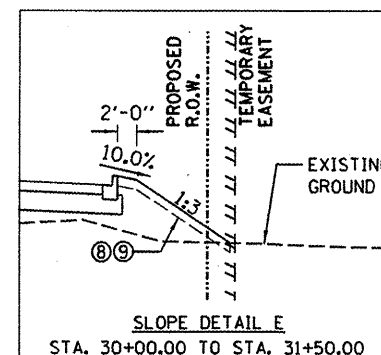

FILE NAME = 1:\08\Jobs\08L0212A\CAD\Road\Sheet\502.dgn	USER NAME = dows00078	DESIGNED - DLC	REVISED -
PLOT SCALE = 20.0000' / 1"	CHECKED - MGD	DRAWN - DLC	REVISED -
PLOT DATE = 09/14/2011	DATE - 9/14/2011	CHECKED - MGD	REVISED -

STATE OF ILLINOIS  
DEPARTMENT OF TRANSPORTATION

PETRI LANE TYPICAL SECTIONS			
SCALE: N/A	SHEET NO.	OF SHEETS	STA. TO STA.

F.A.U. RTE. 6698	SECTION 10-00183-00-FP	COUNTY TAZEWELL	TOTAL SHEETS 81	SHEET NO. 5
FED. ROAD DIST. NO. (ILLINOIS) FED. AID PROJECT W-5093 (154)				