

Bench Mark: - Chisled "□" on top of NW wingwall, Elev. 607.46
 Existing Structure: - Structure No. 011-3172, 33'-0" back-to-back of abutments. 20'-0" out-to-out. Two span concrete slab on steel beams. Road to be closed during construction.
 No Salvage

INDEX OF SHEETS

1. General Plan & Elevation
- 2.-3. Superstructure Details
4. Steel Railing Type S-1
5. Rail Terminal Details
6. Abutments
7. Steel H-Pile Details
- 8.-9. Boring Logs

Reinforcement bars shall conform to the requirements of ASTM A 706 Gr 60. Layout of slope protection system may be varied in the field to suit ground conditions as directed by the Engineer. Reinforcement bars designated (E) shall be epoxy coated.

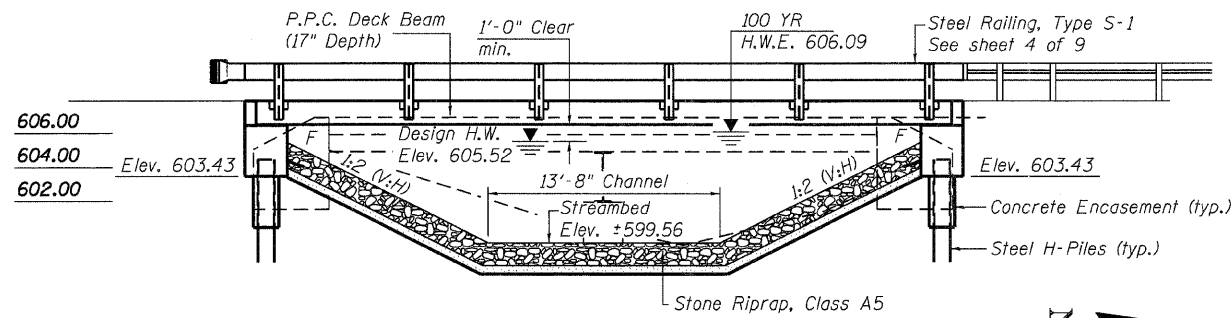

Curled End Section w/ Terminal Markers, typ. (N.E. and S.W. quadrants only)

ELEVATION

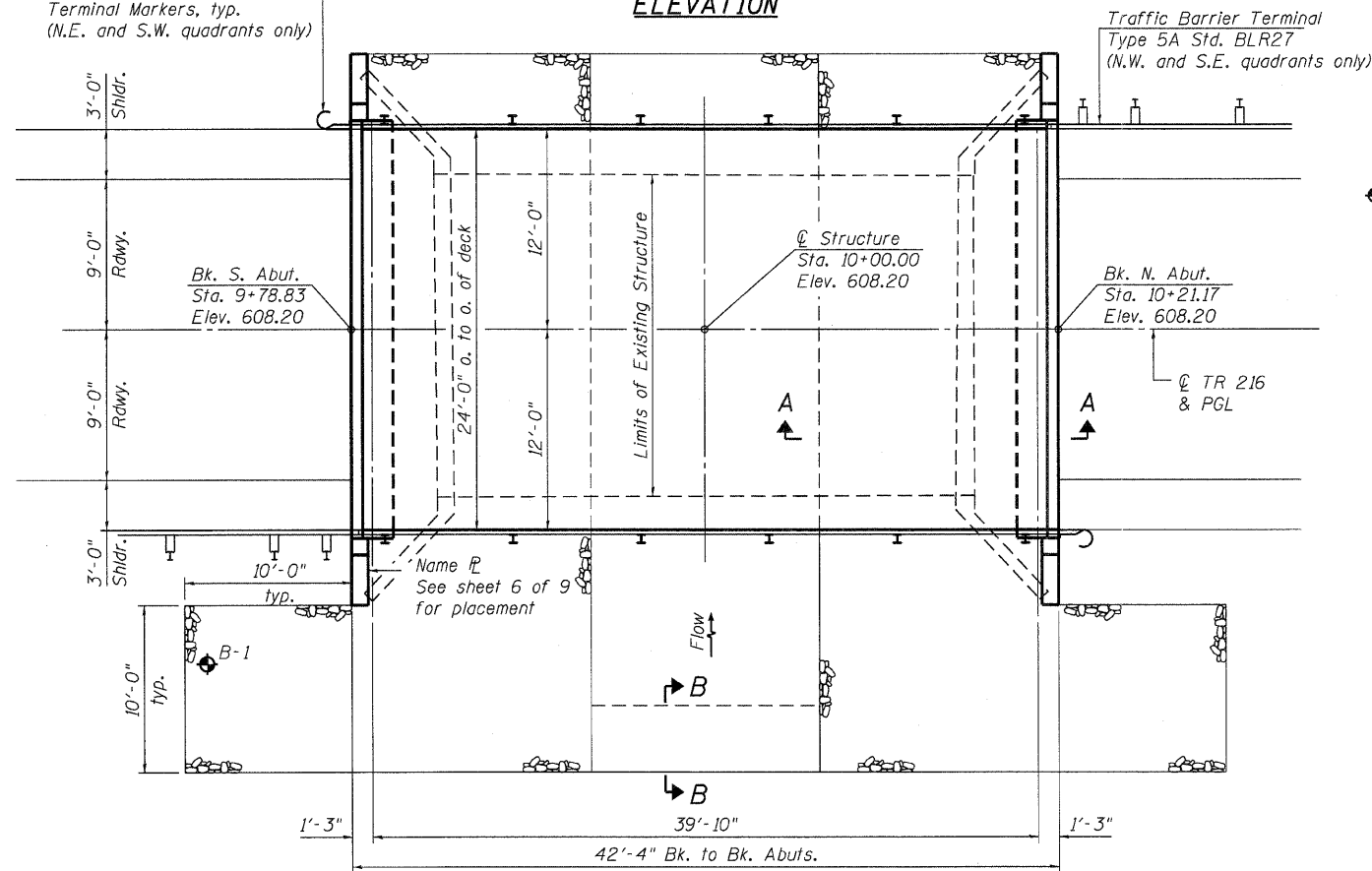

PLAN

DESIGN SCOUR ELEVATION TABLE

Design Scour Elevation (ft.)	S. Abut. 603.43	N. Abut. 603.43
------------------------------	-----------------	-----------------

WATERWAY INFORMATION

Flood	Freq. Yr.	Q C.F.S.	Opening Sq. Ft.		Nat. H.W.E.	Head - Ft.		Headwater El.	
			Exist.	Prop.		Exist.	Prop.	Exist.	Prop.
Design	15	1100	141	156	605.52	1.02	0.73	606.54	606.25
Base	100	1776	144	177	606.09	2.02	1.19	608.11	607.28
Ex Overtopping	8	895	135	-	605.30	0.98	-	606.28	-
Prop Overtopping	9	960	-	150	605.37	-	0.64	-	606.01

PROPOSED PROFILE GRADE
(Along @ TR 216)

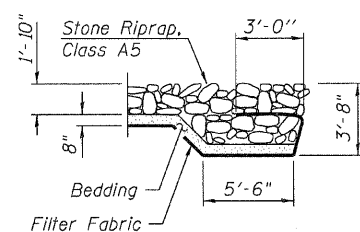
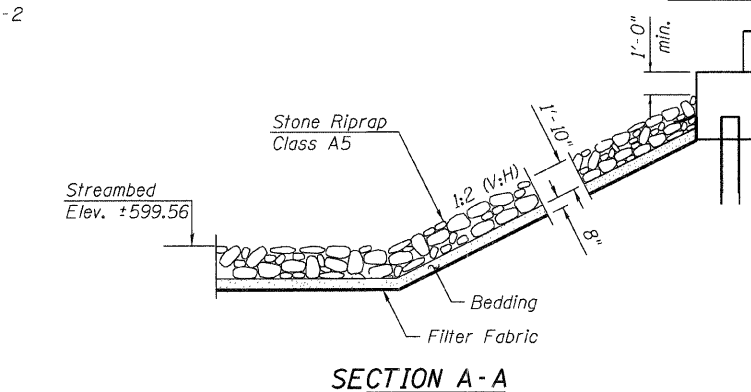
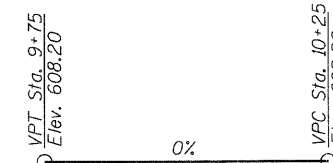

SECTION B-B

BUCKHART CREEK
 BUILT 20 BY
 CHRISTIAN COUNTY
 SECTION 08-16112-00-BR
 TR 216 STA. 10+00
 STR. NO. 011-3418 LOADING HL93

NAME PLATE
See Std. 515001

TOTAL BILL OF MATERIAL

ITEM	UNIT	SUPER	SUB	TOTAL
Channel Excavation	Cu. Yd.		74	74
Stone Riprap, Class A5	Ton		203	203
Filter Fabric	Sq. Yd.		222	222
Removal of Existing Structure	Each		1	1
Structure Excavation	Cu. Yd.		82	82
Concrete Structures	Cu. Yd.		19.5	19.5
Concrete Encasement	Cu. Yd.		2.8	2.8
Precast Prestressed Concrete Deck Beams (17" Depth)	Sq. Ft.	984		984
Reinforcement Bars, Epoxy Coated	Pound		2,880	2,880
Steel Railing, Type S-1	Foot	85		85
Furnishing Steel Piles HP 12x53	Foot		301	301
Driving Piles	Foot		301	301
Test Pile Steel HP 12x53	Each		1	1
Name Plates	Each		1	1
Terminal Marker - Direct Applied	Each	2		2

I certify that to the best of my knowledge, information and belief, this bridge design is structurally adequate for the design loading shown on the plans. The design is an economical one for the style of structure and complies with requirements of the current A.A.S.H.T.O. LRFD Standard Specifications for Highway Bridges.



Scott D. Sanford
 Signed
 11-16-11
 Dated

DESIGN SPECIFICATIONS

AASHTO LRFD 5th Edition with 2010 Interim Specifications

LOADING HL93

50 psf Future Wearing Surface

DESIGN STRESSES

FIELD UNITS

f'c = 3,500 psi
 fy = 60,000 psi (Reinforcement)

PRECAST PRESTRESSED UNITS

f'c = 6,000 psi
 f'ci = 5,000 psi
 f's = 270,000 psi (1/2" low lax strands)
 f'si = 202,000 psi (1/2" low lax strands)

SEISMIC DATA

Seismic Performance Zone (SPZ) = 1
 Design Spectral Acceleration at 1.0 sec. (SD1) = 0.12g
 Design Spectral Acceleration at 0.2 sec. (SDS) = 0.24g
 Soil Site Class = C

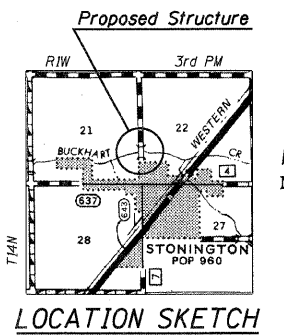

I:\jobs\christiancounty\7166 tr 126 over buckhart creek\cadd\cadd sheets\0113418-00000.dgn

USER NAME = dheerling	DESIGNED - TJJ	REVISED
PLOT SCALE = 0.1/0.000 1" = 10'	DRAWN - DLH	REVISED
PLOT DATE = 11/14/2011	CHECKED - SDS	REVISED
	DATE - 8/25/11	REVISED



7018 KINGSMILL CT.,
 SPRINGFIELD, IL
 (217) 483-9457
 DESIGN FIRM #184001036

STATE OF ILLINOIS
 DEPARTMENT OF TRANSPORTATION

GENERAL PLAN AND ELEVATION

TR 216 OVER BUCKHART CREEK

SCALE: SHEET NO. 1 OF 9 SHEETS @ STA.

T.R. RTE.	SECTION	COUNTY	TOTAL SHEETS	SHEET NO.
216	08-16112-00-BR	CHRISTIAN	26	5
S.N. - 011-3418			CONTRACT	9 8 5 5 9
FED. ROAD DIST. NO. [ILLINOIS] FED. AID PROJECT				