

STATE OF ILLINOIS
DEPARTMENT OF TRANSPORTATION

F.A.I. RTE.	SECTION	COUNTY	TOTAL SHEETS	SHEET NO.
280	81-1B)BRR	ROCK ISLAND	24	1
ILLINOIS CONTRACT NO. 64L93				

FOR INDEX OF SHEETS, SEE SHEET NO. 2
FOR STATE STANDARDS, SEE SHEET NO. 2

**PROPOSED
HIGHWAY PLANS**

F.A.I. ROUTE 280 (I-280)
PROJECT: STP-CXUR(056)
SECTION (81-1B)BRR
TYPE of IMPROVEMENT: BRIDGE REPAIRS
ROCK ISLAND COUNTY

D-92-116-16

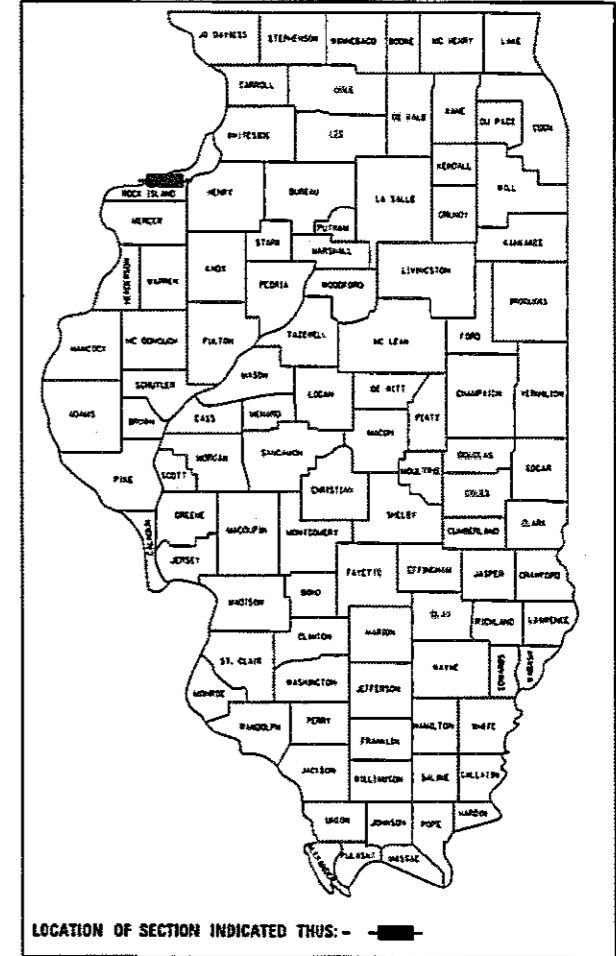

SN 081-0106

C-92-002-17
R.2-1W.

ROCK ISLAND TOWNSHIP, SECTIONS 26 & 35

T.17-18N.

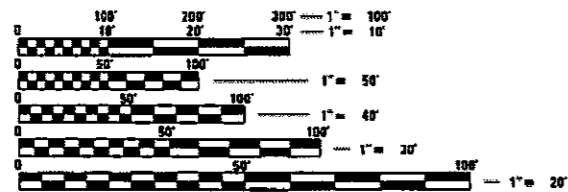
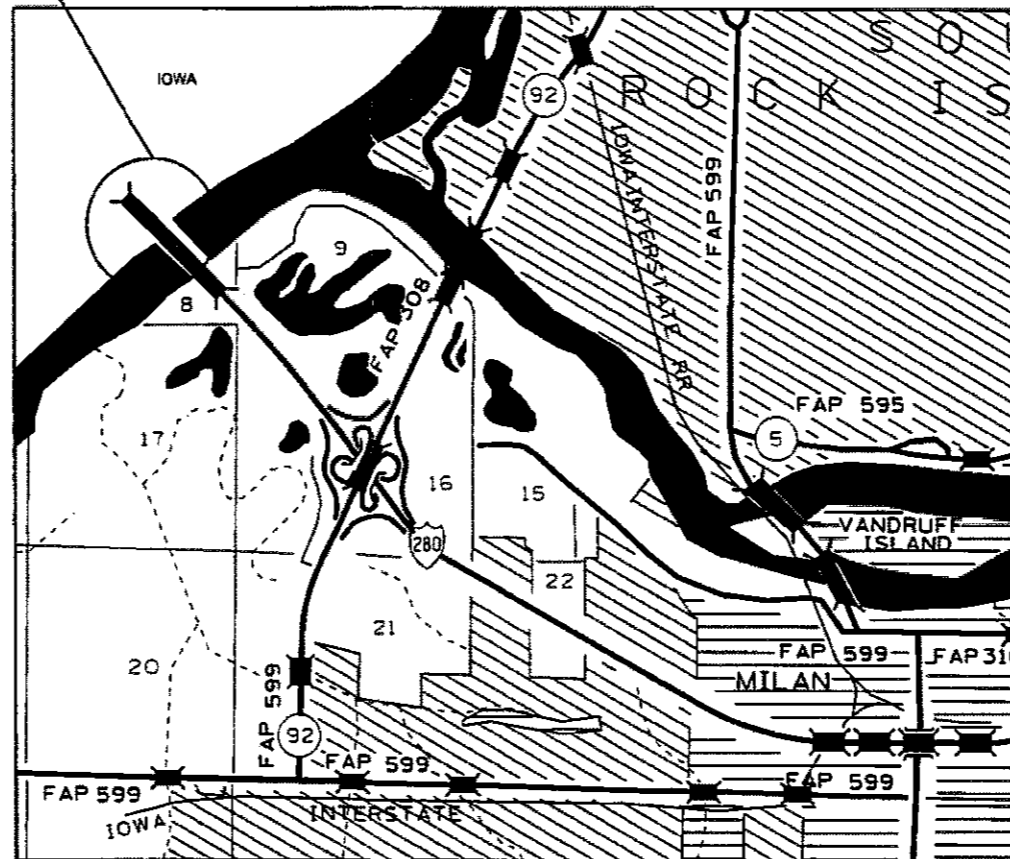

FULL SIZE PLANS HAVE BEEN PREPARED USING STANDARD ENGINEERING SCALES. REDUCED SIZED PLANS WILL NOT CONFORM TO STANDARD SCALES. IN MAKING MEASUREMENTS ON REDUCED PLANS, THE ABOVE SCALES MAY BE USED.

J.U.L.I.E.
JOINT UTILITY LOCATION INFORMATION FOR EXCAVATION
1-800-892-0123
OR 911

PROJECT ENGINEER: DAVID DOSS (815) 284-5416
PROJECT MANAGER: MAHMOUD ETEMADI (815) 284-5393

CONTRACT NO. 64L93

STATE OF ILLINOIS
DEPARTMENT OF TRANSPORTATION

SUBMITTED Dec 18 2017
Maahab
REGIONAL ENGINEER

Feb 2 2018
E.K.
ENGINEER OF DESIGN AND ENVIRONMENT

Feb 2 2018
Paul P. Ch...
DIRECTOR OF PROGRAM DEVELOPMENT

PRINTED BY THE AUTHORITY
OF THE STATE OF ILLINOIS

INDEX OF SHEETS

- 1 COVER SHEET
- 2 INDEX OF SHEETS/STATE STANDARDS/GENERAL NOTES
- 3-4 SUMMARY OF QUANTITIES
- 5-10 STAGE I SN 081-0106
- 11-16 STAGE II SN 081-0106
- 17 GENERAL PLAN & ELEVATION I-280 OVER THE MISSISSIPPI RIVER SN 081-0106
- 18 GENERAL NOTES & BEAM END REPAIRS SN 081-0106
- 19 WEST ABUTMENT REPAIR DETAILS SN 081-0106
- 20 EAST ABUTMENT REPAIR DETAILS SN 081-0106
- 21 TROUGH REPLACEMENT DETAILS SN 081-0106
- 22 ALUMINUM RAILING REPAIR DETAILS SN 081-0106
- 23 PREFORMED JOINT STRIP SEAL SN 081-0106
- 24 BAR SPLICER ASSEMBLY AND MECHANICAL SPLICER DETAILS SN 081-0106

GENERAL NOTES

All Borrow/Waste/Use sites must be approved by the Department prior to removing any material from the project or initiating any earthmoving activities, including temporary stockpiling outside the limits of construction.

The Contractor shall be responsible for protecting utility property during construction operations as outlined in Article 107.31 of the Standard Specifications. A minimum of 48 hours advance notice is required for non-emergency work. The JULIE number is 800-892-0123. The following listed utilities located within the project limits or immediately adjacent to the project construction limits are members of JULIE:

IDOT is not a member of JULIE. If you are near any overhead lighting, intersection lighting or traffic signals, contact the IDOT Traffic Office at 815/284-5469 at least 48 hours prior to work.

Hazards behind Temporary Concrete Barrier Wall

No materials, equipment, vehicles or other hazards shall be within 3'-6" of the temporary concrete barrier wall, measured from the closest point of the barrier wall perpendicular to the hazard. Equipment that is actively working with 3'-6" of the barrier wall may be allowed for a short duration, if approved by the engineer, required for the work activity, and there is not another method to complete the work.

STATE STANDARDS

- 701101-05 OFF-RD OPERATIONS, MULTILANE, 15' (4.5m) TO 24" (600 mm) FROM PAVEMENT EDGE
- 701400-09 APPROACH TO LANE CLOSURE, FREEWAY/EXPRESSWAY
- 701402-12 LANE CLOSURE, FREEWAY/EXPRESSWAY, WITH BARRIER
- 701426-09 LANE CLOSURE, MULTILANE, INTERMITTENT OR MOVING OPERATIONS FOR SPEEDS > 45 MPH
- 701901-07 TRAFFIC CONTROL DEVICES
- 704001-08 TEMPORARY CONCRETE BARRIER

FILE NAME =	USER NAME = jownd	DESIGNED --	REVISED --	STATE OF ILLINOIS DEPARTMENT OF TRANSPORTATION	INDEX OF SHEETS, STATE STANDARDS & GENERAL NOTES				F.A.I. RTE.	SECTION	COUNTY	TOTAL SHEETS	SHEET NO.
g:\illinois\DOT\Bldg\gov\FW007\Documents\DOT 081-0106\District 21\Project\Operations\Bldg Section\Rock Island\081-0106\ADDITION\02-01-cover.dgn		CHECKED --	REVISED --		280	(01-18)RR	ROCK ISLAND	24	2				
PLOT SCALE = 40.0000 1/in.	CHECKED --	REVISED --	CONTRACT NO. 64L93										
PLOT DATE = Nov-02-2017 09:20:11 AM	DATE --	REVISED --	ILLINOIS FED. AID PROJECT										
				SCALE:	SHEET	OF	SHEETS	STA.	TO STA.				

SUMMARY OF QUANTITIES

50% Iowa/50% Illinois
0047

Pay Item #	Description	Unit	Quantity
			<i>URBAN</i>
50102400	CONCRETE REMOVAL	CUYD	27.6
50300255	CONCRETE SUPERSTRUCTURE	CUYD	28.8
50800205	REINFORCEMENT BARS, EPOXY COATED	POUND	3,560
50800515	BAR SPLICERS	EACH	8
52000110	PREFORMED JOINT STRIP SEAL	FOOT	165
67100100	MOBILIZATION	L SUM	1
70100207	TRAFFIC CONTROL AND PROTECTION, STANDARD 701402	EACH	2
70300220	TEMPORARY PAVEMENT MARKING - LINE 4"	FOOT	43,600
70400100	TEMPORARY CONCRETE BARRIER	FOOT	8,675
70400200	RELOCATE TEMPORARY CONCRETE BARRIER	FOOT	8,675
* 78001110	PAINT PAVEMENT MARKING - LINE 4"	FOOT	18,620
X0327980	PAVEMENT MARKING REMOVAL - WATERBLASTING	SQ FT	6,210
X7030005	TEMPORARY PAVEMENT MARKING REMOVAL	SQ FT	14,544
Z0001905	STRUCTURAL STEEL REPAIR	POUND	<i>8970</i>

* SPECIALTY ITEM

FILE NAME	USER NAME = dssdd	DESIGNED	REVISED	STATE OF ILLINOIS DEPARTMENT OF TRANSPORTATION	SUMMARY OF QUANTITIES	F.A.L. RTE	SECTION	COUNTY	TOTAL SHEETS	SHEET NO.	
\\L04ER\DWYER\Bldg\pwr\DOT\Documents\DOT Office\District 2\Projects\Operations\Bldge Section\Rock Island\07-0109\DRAWING\02-04-corrw.dwg						200	(01-10)BRR	ROCK ISLAND	24	3	
Default	PLOT SCALE = 40.0000 /in.	CHECKED	REVISED			CONTRACT NO. 64193					
	PLOT DATE = Nov-02-2017 09:00:24 AM	DATE	REVISED			SCALE:	SHEET	OF	SHEETS	STA.	TO

SUMMARY OF QUANTITIES

50% Iowa/50% Illinois
0047

Pay Item #	Description	Unit	Quantity
			URBAN
70600250	IMPACT ATTENUATORS, TEMPORARY (NON- REDIRECTIVE), TEST LEVEL 3	EACH	2
70600350	IMPACT ATTENUATORS, RELOCATE (NON- REDIRECTIVE), TEST LEVEL 3	EACH	2
X0326719	FALCON PROTECTION	EACH	2

2

REV

Traffic Control Plan Stage I

Iowa approach

Refer to Standard 701402 for additional signs and devices.

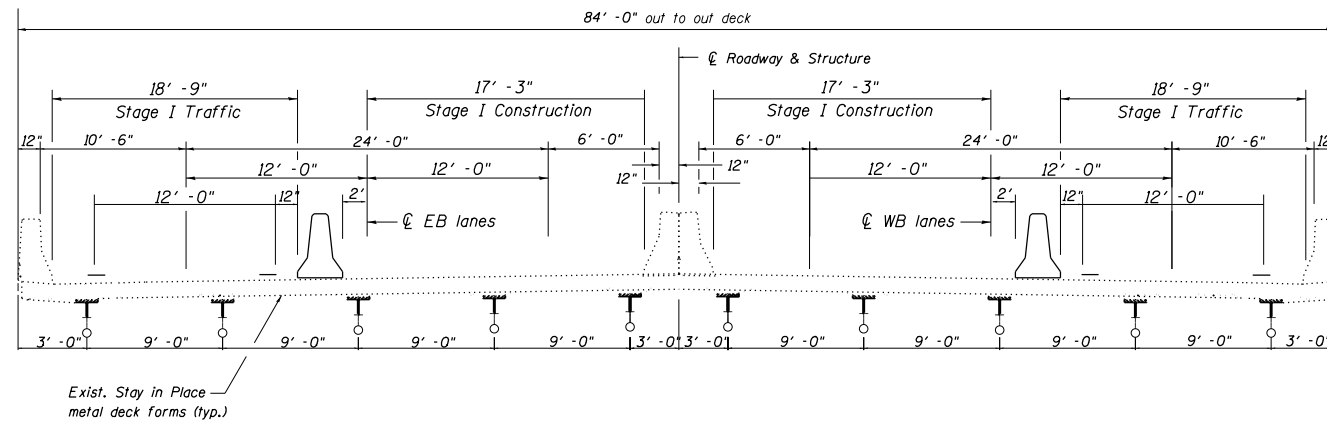
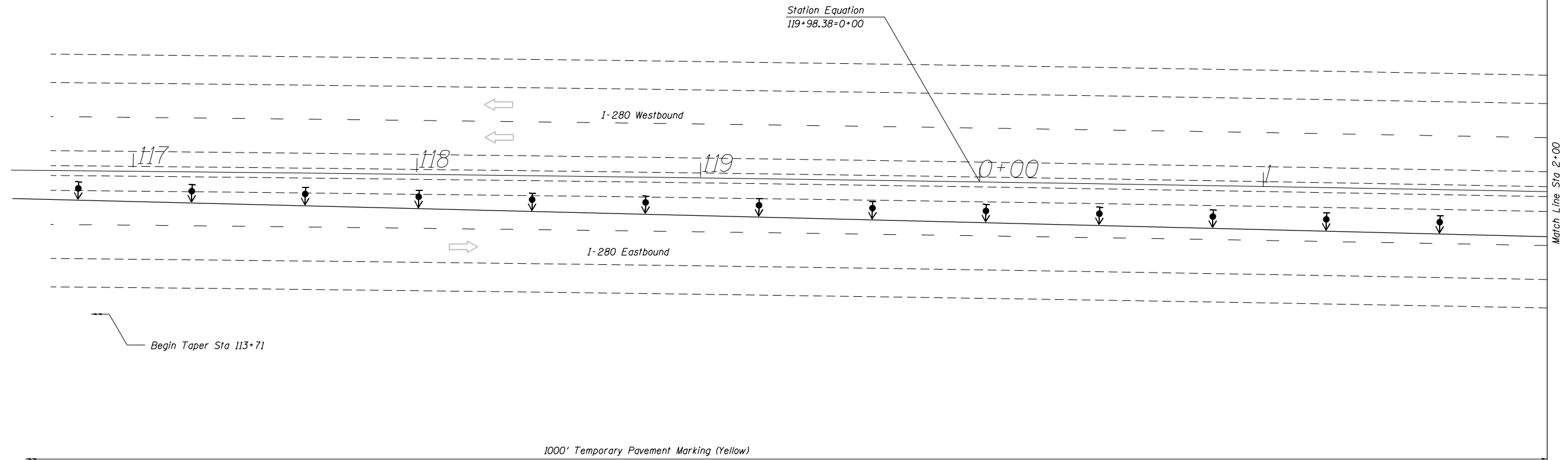
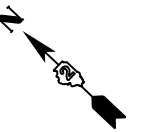

TYPICAL CROSS SECTION - STAGE I

Pavement Marking Removal		Sq Ft
Iowa shift+tangent+Illinois shift		
Stage I		
Eastbound		
Right edgeline	4,610' x 6"	2,305
Westbound		
Right edgeline	4,610' x 6"	2,305
Stage II		
Eastbound		
Left edgeline	4,610' x 6"	2,305
Westbound		
Left edgeline	4,610' x 6"	2,305
		9,220 Sq Ft

FILE NAME =	USER NAME = dssdd	DESIGNED -	REVISED -
pvc\1184\EBIDINTEG.1184\gov\PWIDOT\Documents\DOT Office\District 2\Projects\Operations\Bridg Section\Rock Island\081-0106\64-DRAWN		CHECKED -	REVISED -
Default	PLOT SCALE = 40,0000 /In	DATE -	REVISED -
	PLOT DATE = Nov-02-2017 09:00:47 AM		

**STATE OF ILLINOIS
DEPARTMENT OF TRANSPORTATION**

**TRAFFIC CONTROL PLAN
SN 081-0106 STAGE I IOWA APPROACH**

SCALE: SHEET OF SHEETS STA. TO STA.

F.A.I. RTE.	SECTION	COUNTY	TOTAL SHEETS	SHEET NO.
280	(81-1B)BR	ROCK ISLAND	24	5
CONTRACT NO. 64L93				
		ILLINOIS	FED. AID PROJECT	

Traffic Control Plan Stage I

Iowa approach

Refer to Standard 701402 for additional signs and devices.

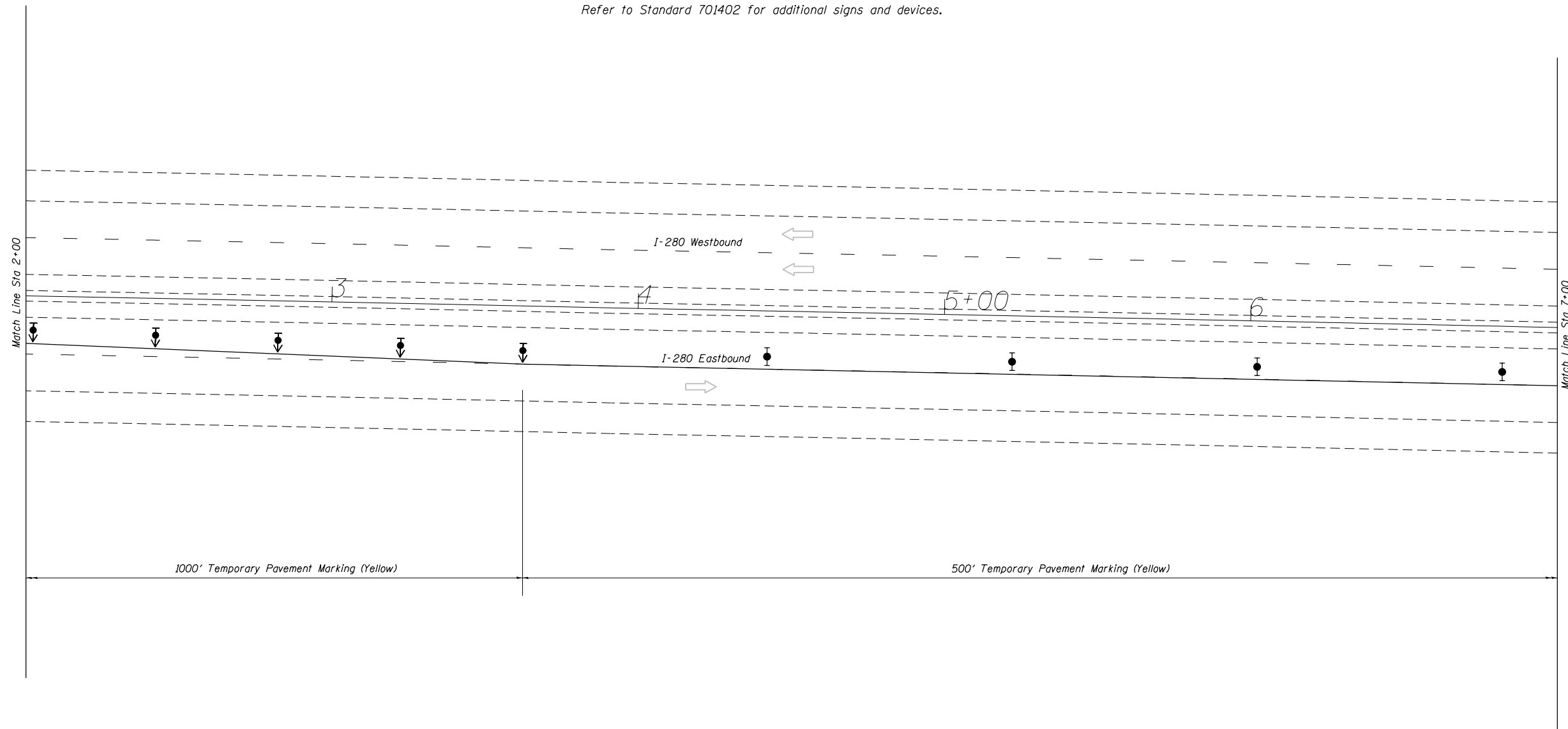
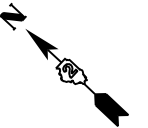

Temporary Pavement Marking - Line 4"

Stage I Eastbound		Stage I Westbound		Stage II Eastbound		Stage II Westbound	
1000' Taper	1000	1000' Taper	1000	1000' Taper	1000	1000' Taper	1000
500' Tangent	500	500' Tangent	500	500' Tangent	500	500' Tangent	500
Lane shift	2x175	Lane shift	2x175	Lane shift	2x175	Lane shift	2x175
50' Ext.	2x50	50' Ext.	2x50	50' Ext.	2x50	50' Ext.	2x50
Bridge	2x4250	Bridge	2x4250	Bridge	2x4250	Bridge	2x4250
50' Ext	2x50	50' Ext	2x50	50' Ext	2x50	50' Ext	2x50
Lane shift	2x175	Lane shift	2x175	Lane shift	2x175	Lane shift	2x175
10,900		10,900		10,900		10,900	

Total 4x10,900 = 43,600 Ft

Traffic Control Plan Stage I

Iowa approach

Refer to Standard 701402 for additional signs and devices.

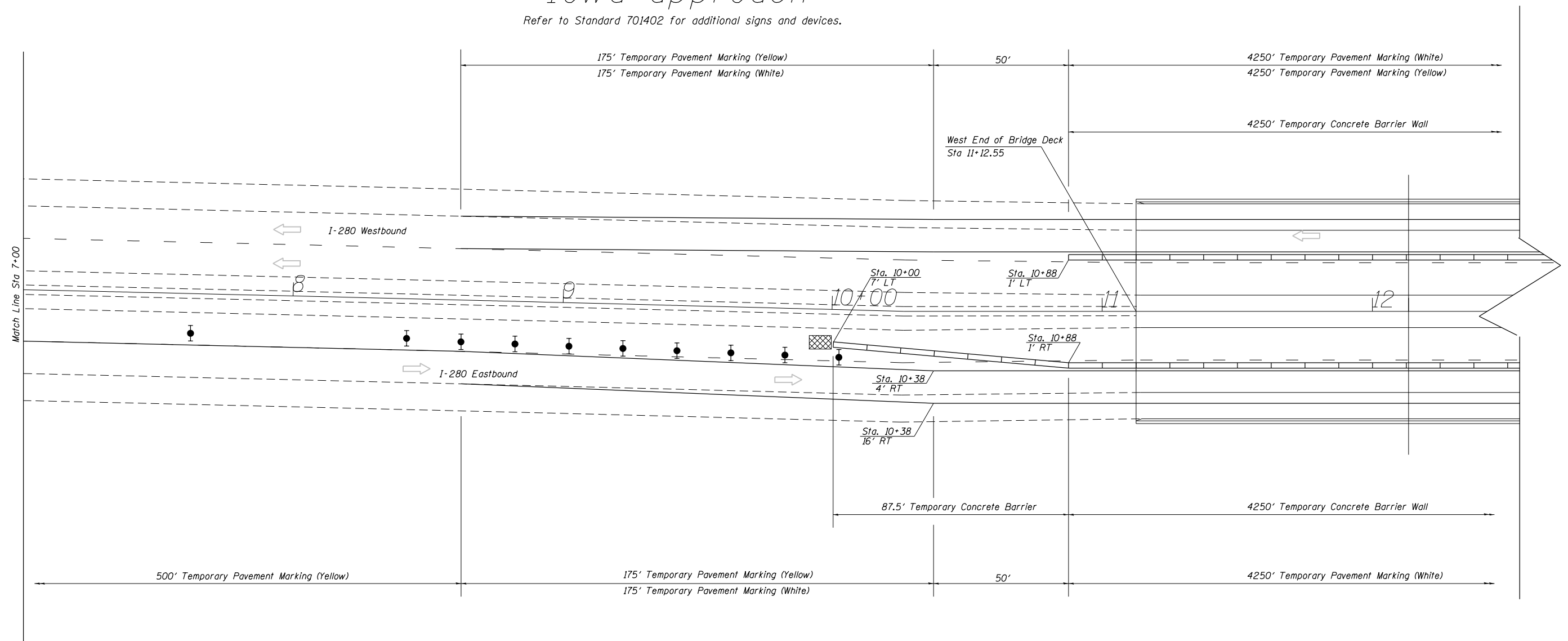
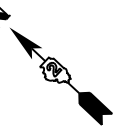

Temporary Concrete Barrier Wall		Ft
Stage I		
Eastbound	87.5 * 4250 =	4,337.5
Westbound	87.5 * 4250 =	4,337.5
Total		8,675 Ft

Temporary Impact Attenuators		Each
Stage I		
Eastbound		1
Westbound		1
Total		2 Each

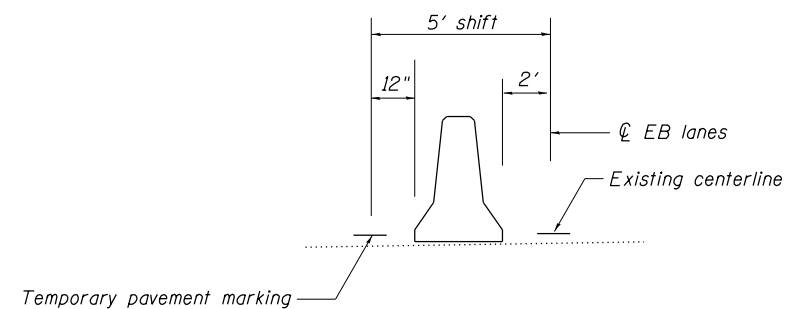

FILE NAME =	USER NAME = dssdd	DESIGNED -	REVISED -
pvc\11084EBDINTEG\11084EBDINTEG\DWG\DOT Office\District 2\Projects\Operations\Bridges Section\Rock Island\081-0106\081-0106-01-001.dwg		DRAWN -	REVISED -
	PLOT SCALE = 40,0000 / 1in	CHECKED -	REVISED -
	PLOT DATE = Nov-02-2017 09:01:08 AM	DATE -	REVISED -

STATE OF ILLINOIS
DEPARTMENT OF TRANSPORTATION

TRAFFIC CONTROL PLAN
SN 081-0106 STAGE I IOWA APPROACH

F.A.I. RTE.	SECTION	COUNTY	TOTAL SHEETS	SHEET NO.
280	(81-1B)BR	ROCK ISLAND	24	7
CONTRACT NO. 64L93				
SCALE:		SHEET OF SHEETS	STA.	TO STA.

SCALE: SHEET OF SHEETS STA. TO STA.

ILLINOIS FED. AID PROJECT

Traffic Control Plan Stage I

Illinois approach

Refer to Standard 701402 for additional signs and devices.

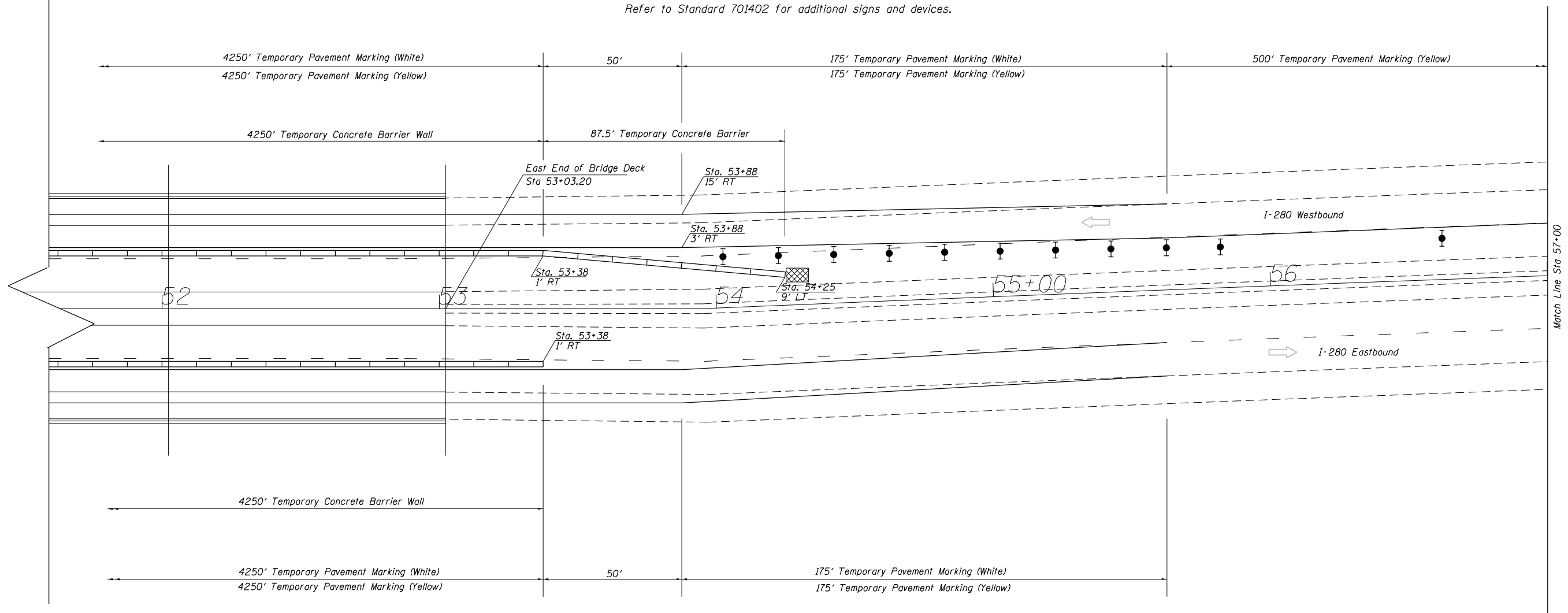
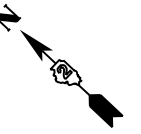

Match Line Sta 57+00

FILE NAME =	USER NAME = dosdd	DESIGNED -	REVISED -	STATE OF ILLINOIS DEPARTMENT OF TRANSPORTATION	TRAFFIC CONTROL PLAN SN 081-0106 STAGE I ILLINOIS APPROACH	F.A.I. RTE.	SECTION	COUNTY	TOTAL SHEETS	SHEET NO.
pvc\11084ERIDINTEG\11084.govc\PWIDOT\Documents\DOT Office\11084\11084\Projects\Operations\Bridges Section\Rock Island\081-0106\081-0106-01\081-0106-01-01.dwg		DRAWN	REVISED -			280	(81-1B)BR	ROCK ISLAND	24	8
PLOT SCALE = 40,0000 / In.	CHECKED -	REVISED -				CONTRACT NO. 64L93				
Default	PLOT DATE = Nov-02-2017 09:01:16 AM	DATE -	REVISED -			SCALE:	SHEET	OF	SHEETS	STA.

Traffic Control Plan Stage I

Illinois approach

Refer to Standard 701402 for additional signs and devices.

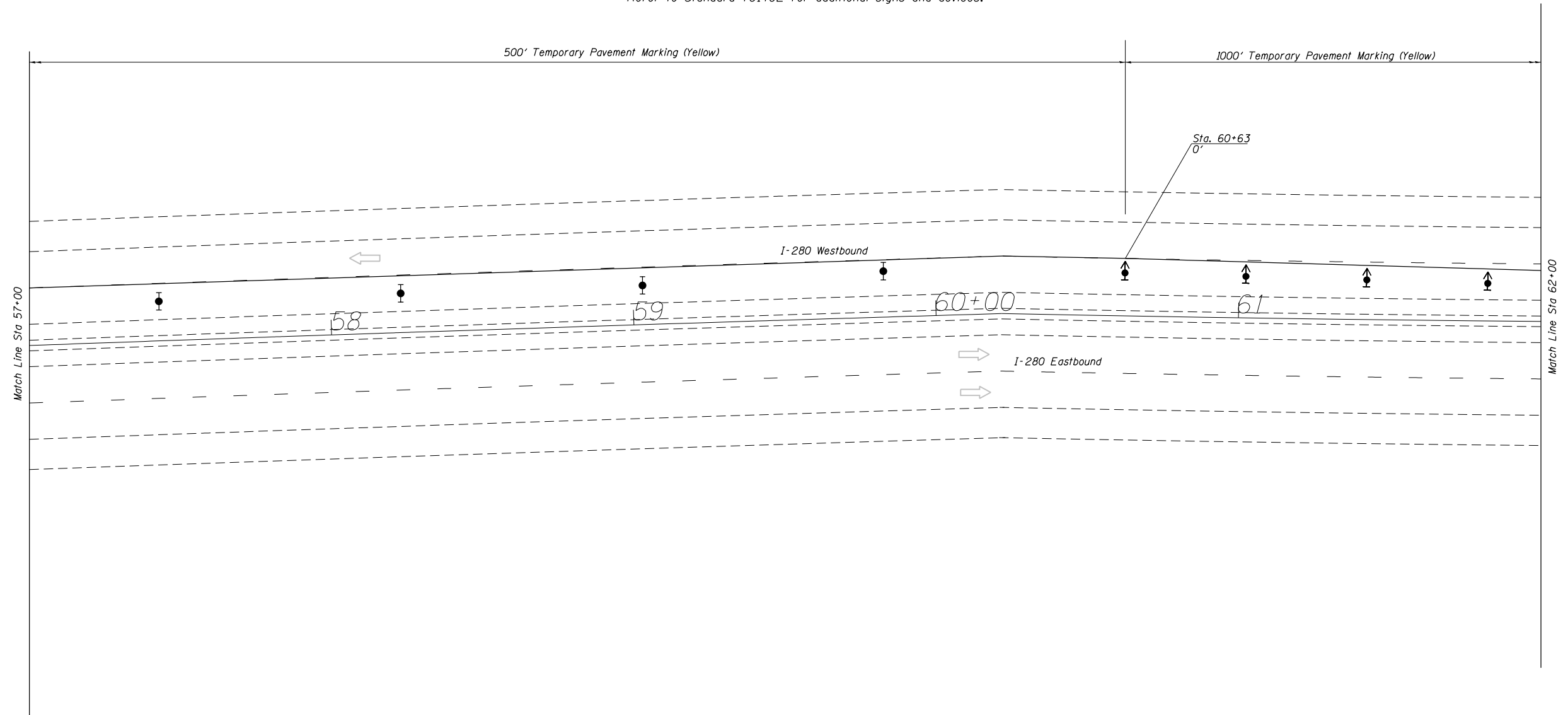
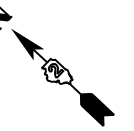

FILE NAME =	USER NAME = dssdd	DESIGNED -	REVISED -
pvc\11084ERIDINTEG\11084\govc\PMW007\Documents\DOT Office\District 2\Projects\Operations\Bridges Section\Rock Island\081-0106\64\DRAWN			REVISED -
	PLOT SCALE = 40,0000 /in.	CHECKED -	REVISED -
Default	PLOT DATE = Nov-02-2017 09:01:25 AM	DATE -	REVISED -

**STATE OF ILLINOIS
DEPARTMENT OF TRANSPORTATION**

**TRAFFIC CONTROL PLAN
SN 081-0106 STAGE I ILLINOIS APPROACH**

SCALE:	SHEET	OF	SHEETS	STA.	TO STA.
--------	-------	----	--------	------	---------

F.A.I. RTE.	SECTION	COUNTY	TOTAL SHEETS	SHEET NO.
280	(81-1B)BR	ROCK ISLAND	24	9
CONTRACT NO. 64L93				
ILLINOIS			FED. AID PROJECT	

Traffic Control Plan Stage I

Illinois approach
Refer to Standard 701402 for additional signs and devices.

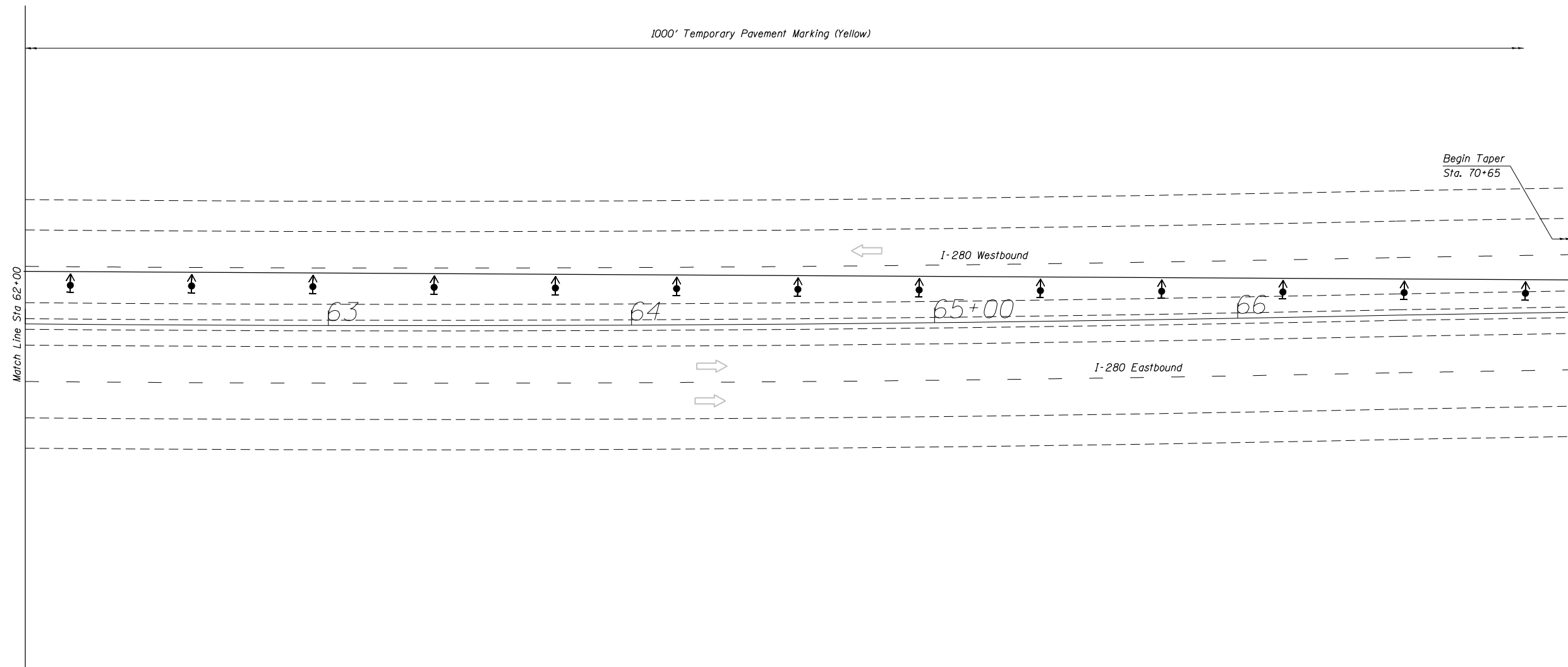
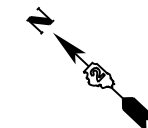

FILE NAME =	USER NAME = dssdd	DESIGNED -	REVISED -
pvc\11084EBIDINTEG\11084.govc\PWIDOT\Documents\DOT Office\District 2\Projects\Operations\Bridg Section\Rock Island\081-0106\64-DRAWN		CHECKED -	REVISED -
Default	PLOT SCALE = 40,0000 /in.	DATE -	REVISED -
	PLOT DATE = Nov-02-2017 09:01:32 AM		

**STATE OF ILLINOIS
DEPARTMENT OF TRANSPORTATION**

**TRAFFIC CONTROL PLAN
SN 081-0106 STAGE I ILLINOIS APPROACH**

SCALE: SHEET OF SHEETS STA. TO STA.

F.A.I. RTE.	SECTION	COUNTY	TOTAL SHEETS	SHEET NO.
280	(81-1B)BR	ROCK ISLAND	24	10
CONTRACT NO. 64L93				
		ILLINOIS	FED. AID PROJECT	

Traffic Control Plan Stage II

Iowa approach

Refer to Standard 701402 for additional signs and devices.

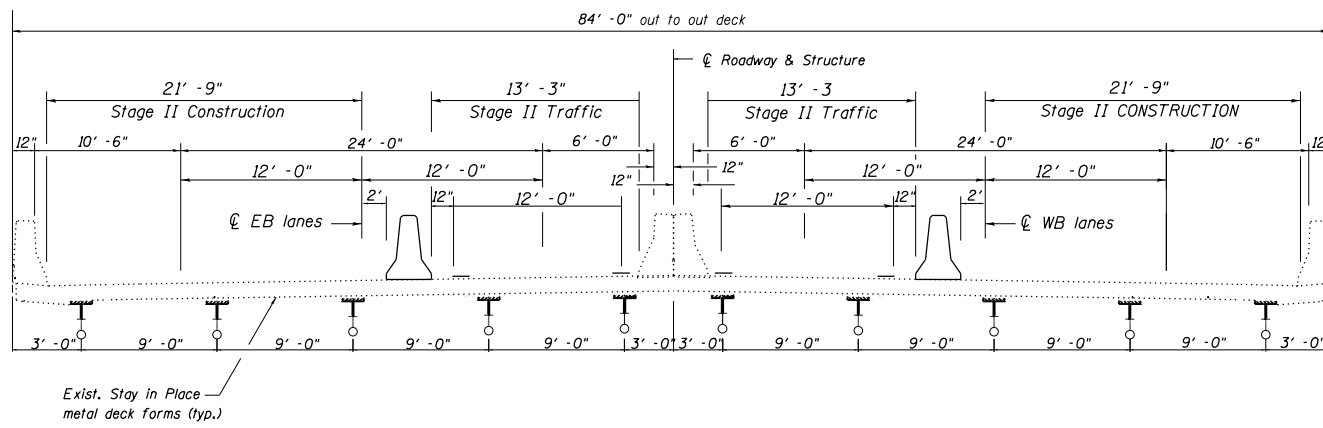
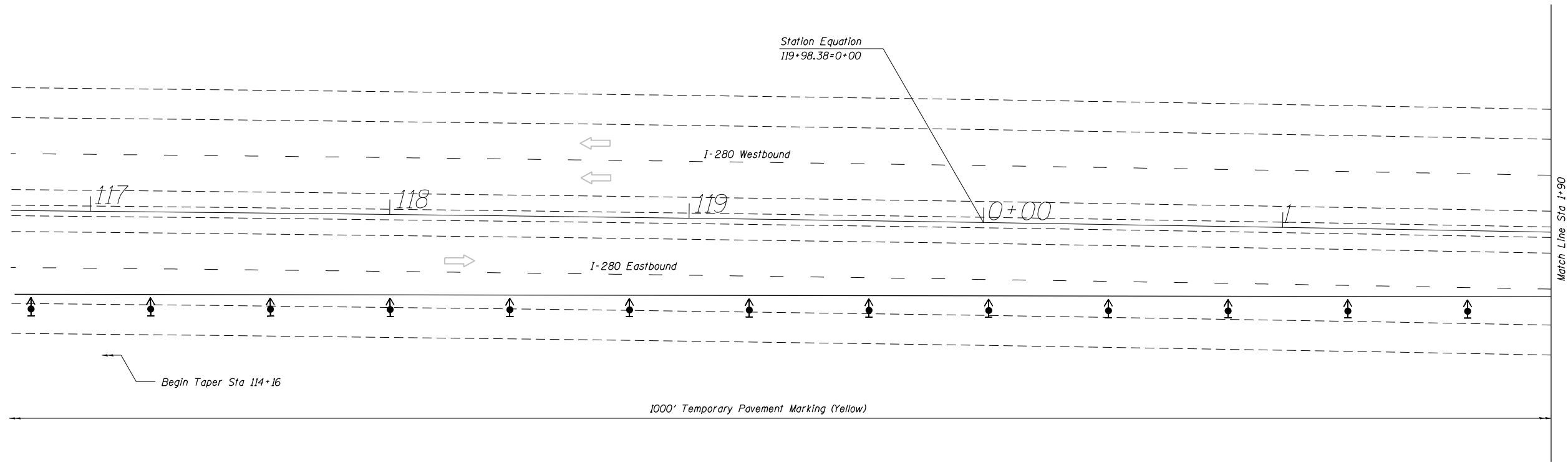
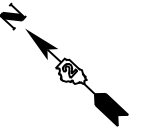

TYPICAL CROSS SECTION - STAGE II

FILE NAME =	USER NAME = dssdd	DESIGNED -	REVISED -
pvc\11084EBIDINTEG\11084EBIDINTEG\Documents\DOT Office\District 2\Projects\Operations\Bridg Section\Rock Island\081-0106\64-DRAWN		CHECKED -	REVISED -
Default	PLOT SCALE = 40,0000 /In.	DATE -	REVISED -
	PLOT DATE = Nov-02-2017 09:01:39 AM		

**STATE OF ILLINOIS
DEPARTMENT OF TRANSPORTATION**

**TRAFFIC CONTROL PLAN
SN 081-0106 STAGE II IOWA APPROACH**

SCALE: SHEET OF SHEETS STA. TO STA.

F.A.I. RTE.	SECTION	COUNTY	TOTAL SHEETS	SHEET NO.
280	(81-1B)BR	ROCK ISLAND	24	11
CONTRACT NO. 64L93				
		ILLINOIS	FED. AID PROJECT	

Traffic Control Plan Stage II

Iowa approach

Refer to Standard 701402 for additional signs and devices.

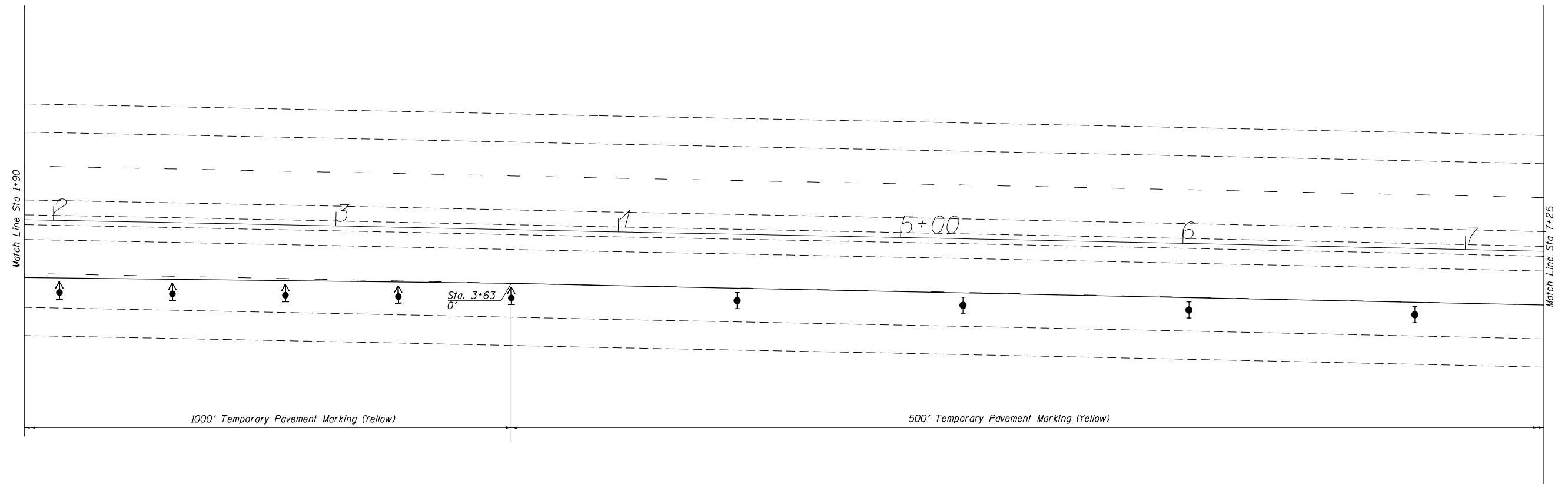
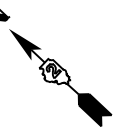

Workzone Pavement Marking Removal	
Stage I	Sq Ft
Eastbound	3,575
Westbound	3,575
Stage II	
Eastbound	3,575
Westbound	3,575
Total 14,300 Sq Ft	

Traffic Control Plan Stage II

Iowa approach

Refer to Standard 701402 for additional signs and devices.

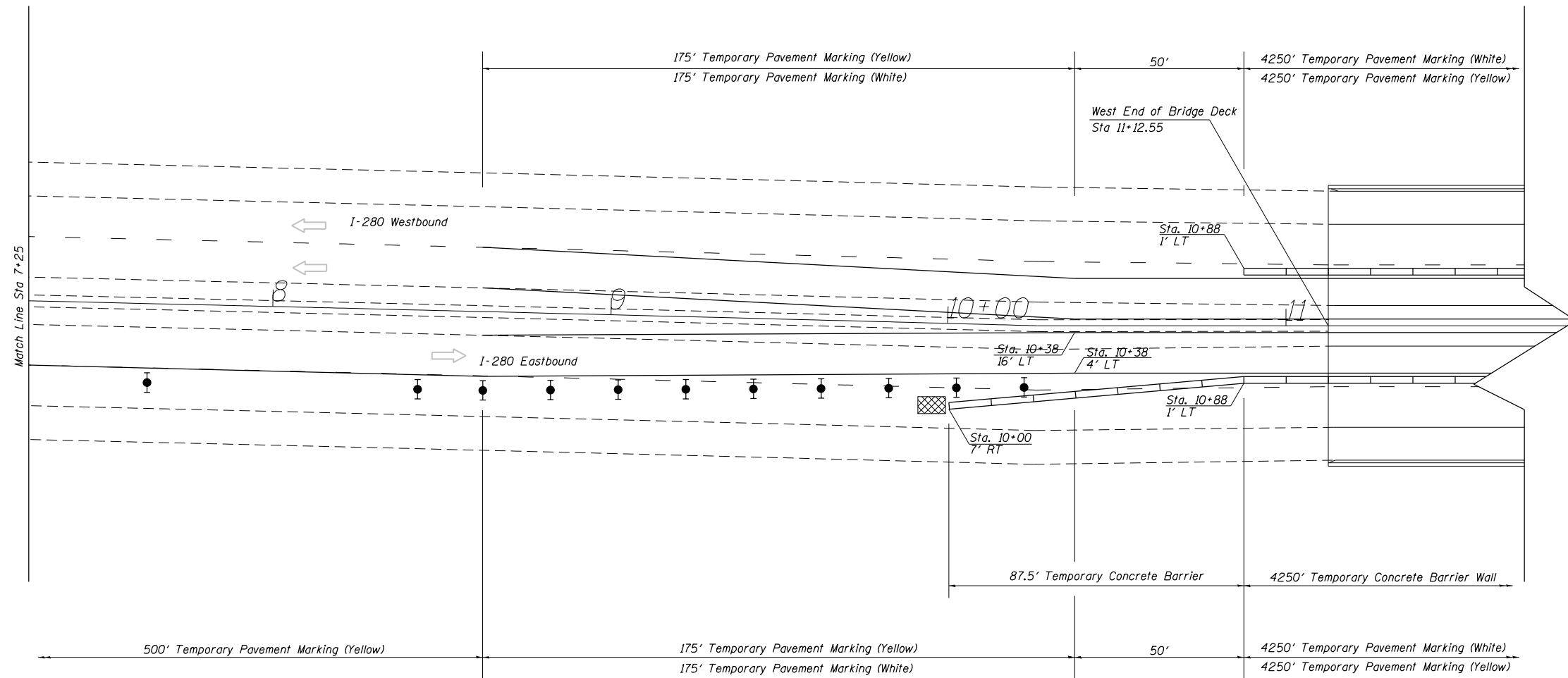
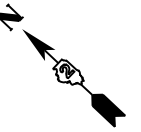

Relocate Temporary Concrete Barrier Wall	
Stage II	
	Ft
Eastbound	87.5 + 4250 = 4,337.5
Westbound	87.5 + 4250 = 4,337.5
Total	8,675 Ft

Relocate Temporary Impact Attenuators	
Stage II	
	Each
Eastbound	1
Westbound	1
Total	2 Each

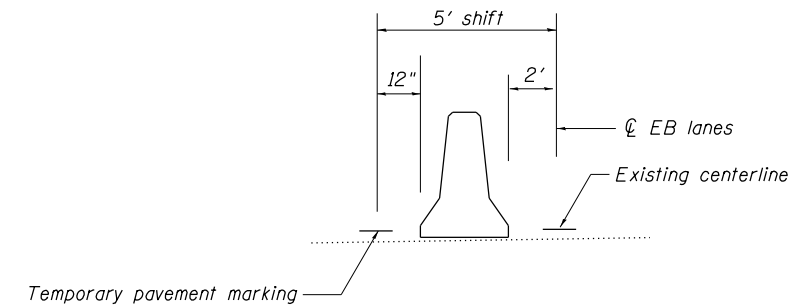

Barrier wall/Traffic Shift detail

FILE NAME =	USER NAME = dssdd	DESIGNED -	REVISED -	STATE OF ILLINOIS DEPARTMENT OF TRANSPORTATION	TRAFFIC CONTROL PLAN SN 081-0106 STAGE II IOWA APPROACH				F.A.I. RTE.	SECTION	COUNTY	TOTAL SHEETS	SHEET NO.
pvc\11084EBIDINTEG\11084EBIDINTEG\Documents\DOT Office\Dist\Dist 2\Projects\Operations\Bridges Section\Rock Island\081-0106\081-0106-01-01-01.dwg		DRAWN	REVISED -						280	(81-1B)BR	ROCK ISLAND	24	13
Default	PLOT SCALE = 40,0000 / In.	CHECKED -	REVISED -		CONTRACT NO. 64L93				ILLINOIS FED. AID PROJECT				
	PLOT DATE = Nov-02-2017 09:01:55 AM	DATE -	REVISED -		SCALE:	SHEET	OF	SHEETS	STA.	TO	STA.		

Traffic Control Plan Stage II

Illinois approach

Refer to Standard 701402 for additional signs and devices.

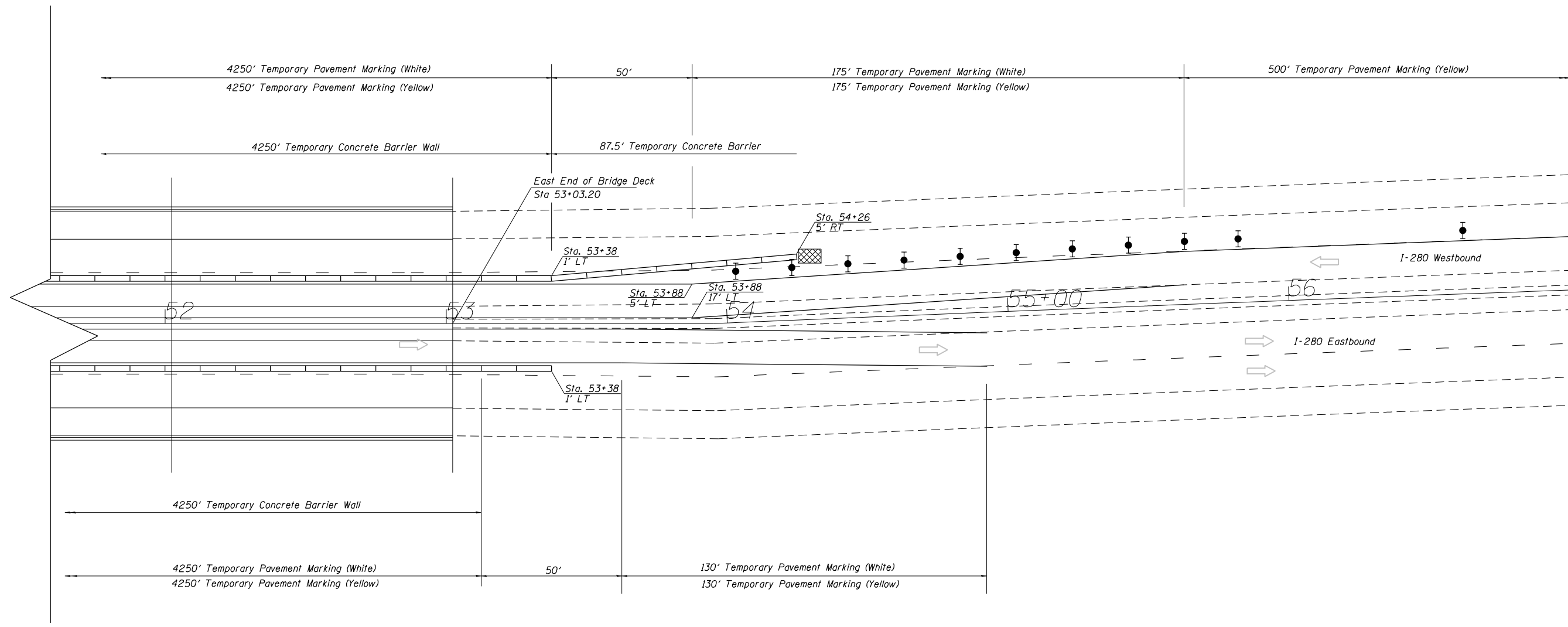
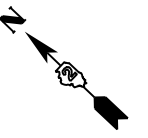

FILE NAME =	USER NAME = dssdd	DESIGNED -	REVISED -	STATE OF ILLINOIS DEPARTMENT OF TRANSPORTATION	TRAFFIC CONTROL PLAN SN 081-0106 STAGE II ILLINOIS APPROACH	F.A.I. RTE.	SECTION	COUNTY	TOTAL SHEETS	SHEET NO.
pvc\11884EBIDINTEG\11884EBIDINTEG\Documents\DOT Office\District 2\Projects\Operations\Bridges Section\Rock Island\081-0106\081-0106-01-01-01.dwg		DRAWN	REVISED -			280	(81-1B)BR	ROCK ISLAND	24	14
PLOT SCALE = 40,0000 / in.	CHECKED -	REVISED -				CONTRACT NO. 64L93				
Default	PLOT DATE = Nov-02-2017 09:02:03 AM	DATE -	REVISED -			SCALE:	SHEET	OF	SHEETS	STA.

Traffic Control Plan Stage II

Illinois approach
Refer to Standard 701402 for additional signs and devices.

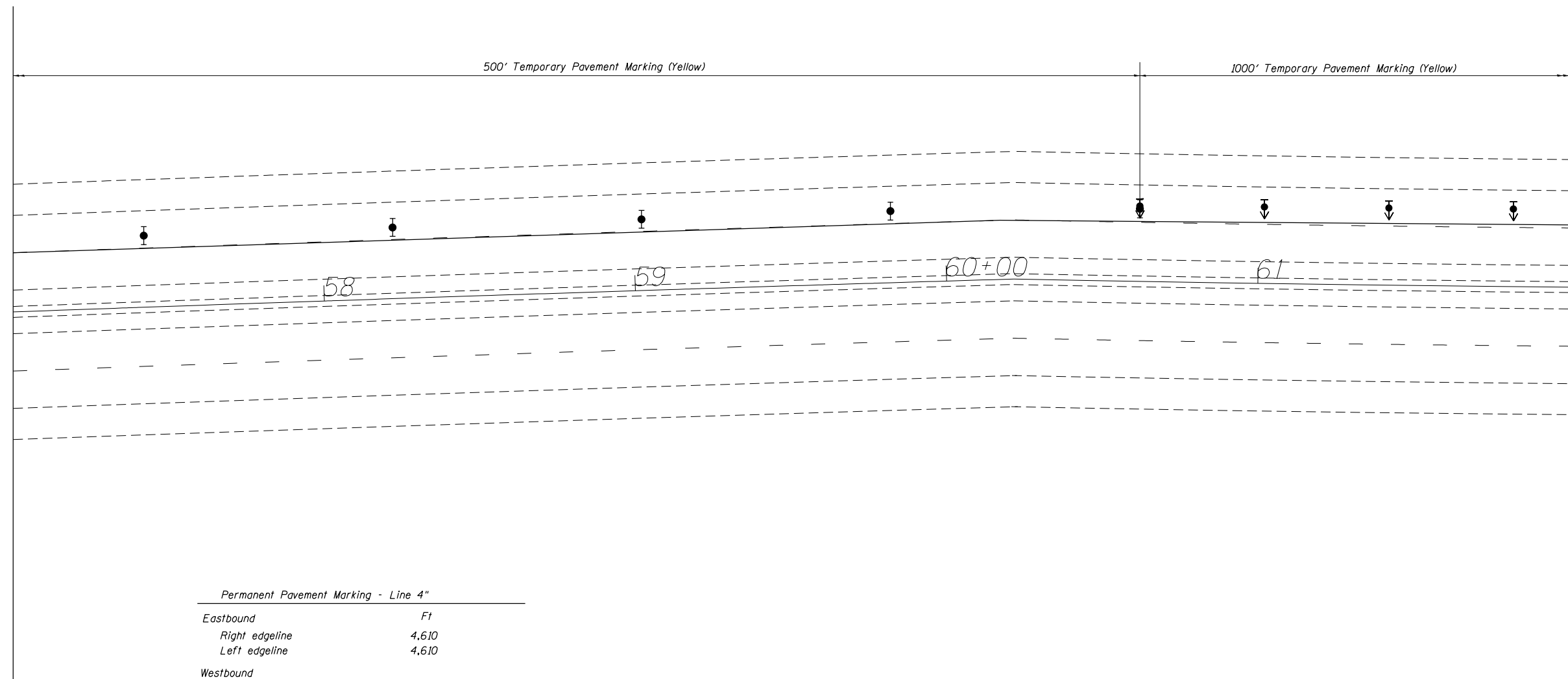
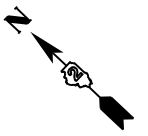

Permanent Pavement Marking - Line 4"

<i>Eastbound</i>	
<i>Right edgeline</i>	<i>4,610</i>
<i>Left edgeline</i>	<i>4,610</i>
<i>Westbound</i>	
<i>Right edgeline</i>	<i>4,610</i>
<i>Left edgeline</i>	<i>4,610</i>
<i>Total 18,440 Ft</i>	

Traffic Control Plan Stage II

Illinois approach
Refer to Standard 701402 for additional signs and devices.

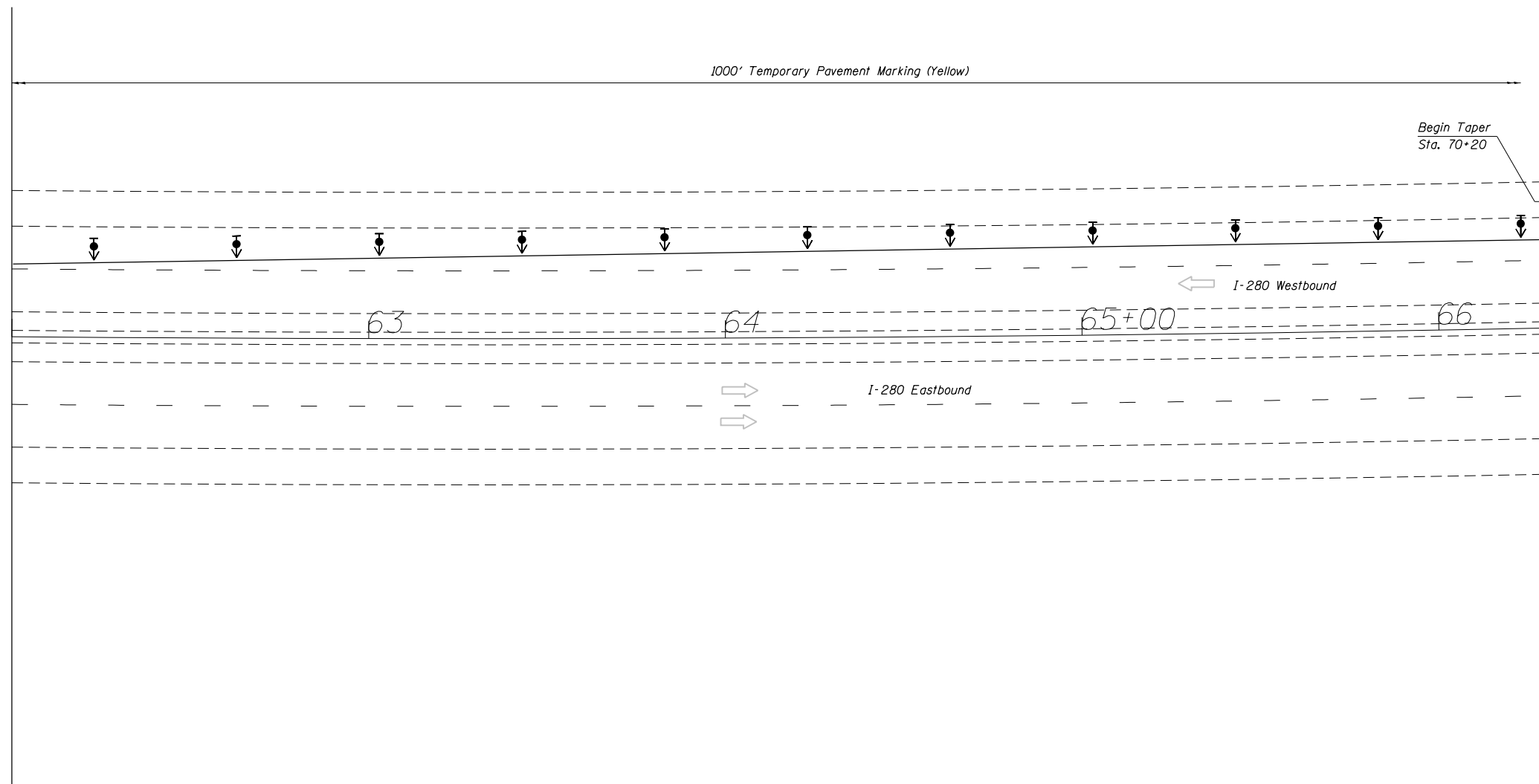
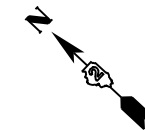

FILE NAME =	USER NAME = dssdd	DESIGNED -	REVISED -
pvc\1184EBIDINTEG\1184EBIDINTEG\Documents\DOT Office\District 2\Projects\Operations\Bridg Section\Rock Island\081-0106\64-DRAWN		CHECKED -	REVISED -
	PLOT SCALE = 40,0000 / In.	DATE -	REVISED -
Default	PLOT DATE = Nov-02-2017 09:02:20 AM		

STATE OF ILLINOIS
DEPARTMENT OF TRANSPORTATION

TRAFFIC CONTROL PLAN
SN 081-0106 STAGE II ILLINOIS APPROACH

SCALE: SHEET OF SHEETS STA. TO STA.

F.A.I. RTE.	SECTION	COUNTY	TOTAL SHEETS	SHEET NO.
280	(81-1B)BR	ROCK ISLAND	24	16
CONTRACT NO. 64L93				
		ILLINOIS	FED. AID PROJECT	

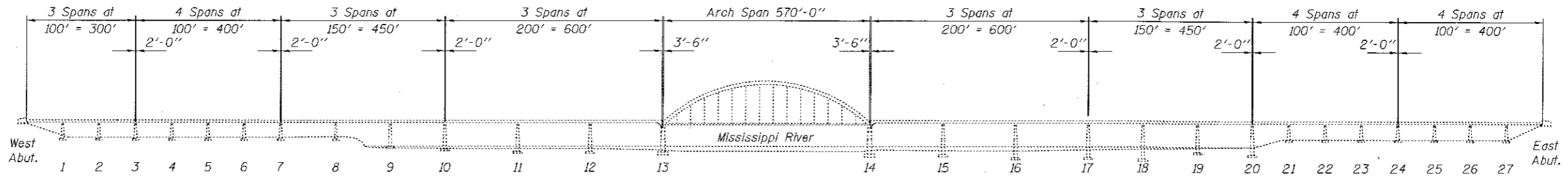

ELEVATION

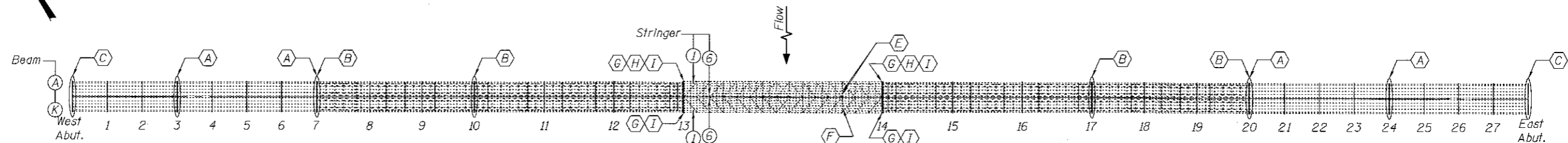

PLAN

- A, B - Beam end repairs. See Table A on sheet 2 of 8.
- C - Replace joints with Preformed Joint Strip Seal.
- D - Paint only. See Repair D, this sheet.
- E, F - Stiffener repairs. See Repairs E & F on sheet 6 of 8.
- G, H, I - Tie Arch repairs. See Repairs G, H & I on sheet 5 of 8.

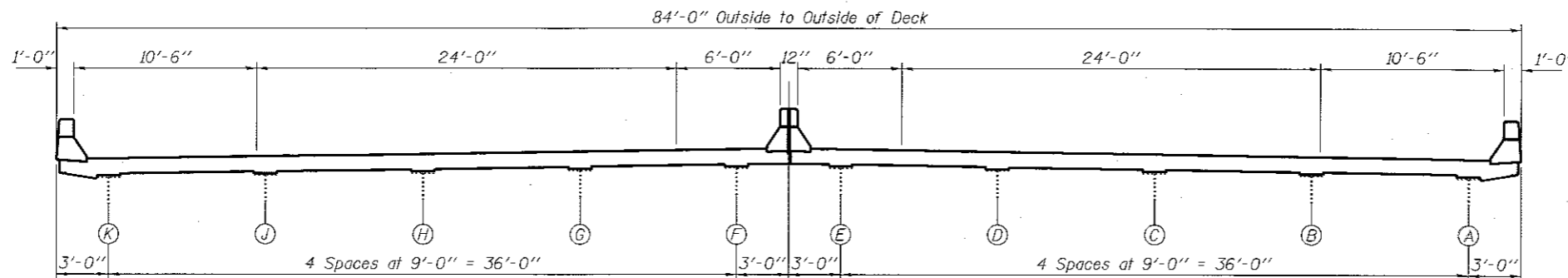

SECTION THRU APPROACH SPANS

(Looking West)
See sheets 3 & 4 of 8 for staging

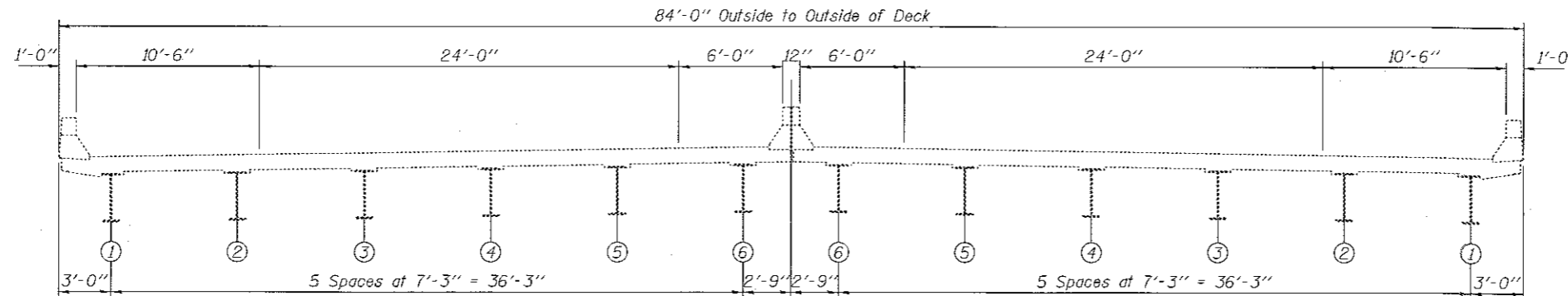

SECTION THRU ARCH SPAN

(Looking West)

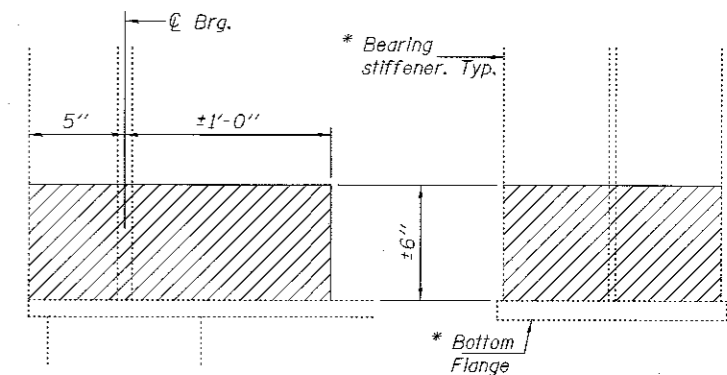

ELEVATION

END VIEW

REPAIR D

Hatched areas indicate cleaning and painting.
Cost included with Structural Steel Repairs.

TABLE A

PIER	SPAN	GIRDER	BRG. STIFFENER	BOTTOM FLANGE
7	7	G	5/8" x 5 1/2"	1" x 12"
7	8	E & J	3/4" x 7 1/2"	7/8" x 16"
10	10	B & E	3/4" x 7 1/2"	7/8" x 16"
10	11	D & E	7/8" x 7 1/2"	1" x 16"
17	17	G, J & K	7/8" x 7 1/2"	1" x 16"

TOTAL BILL OF MATERIAL

ITEM	UNIT	QUANTITY
Concrete Removal	Cu. Yd.	27.6
Concrete Superstructure	Cu. Yd.	28.8
Reinforcement Bars, Epoxy Coated	Pound	3560
Structural Steel Repair	Pound	8970
Preformed Joint Strip Seal	Foot	165
Bar Splicers	Each	8

DESIGN STRESSES

FIELD UNITS

f'c = 4,000 psi (Concrete)
fy = 36,000 psi (Structural Steel)
fy = 60,000 psi (Reinforcement)



EXPIRES 11-30-2018

DESIGNED	<i>M. L. D. RPN</i>	EXAMINED	<i>Tracy A. Burt</i>	DATE	JANUARY 16, 2018
CHECKED	<i>Ryan Reganzano</i>	PASSED	<i>David Carl Puzey</i>	REVISIONS	
DRAWN	<i>bativa</i>				
CHECKED	<i>M. L. D. RPN</i>				

STATE OF ILLINOIS
DEPARTMENT OF TRANSPORTATION

GENERAL PLAN & ELEVATION
I-280 OVER THE MISSISSIPPI RIVER
SN 081-0106

SHEET NO. 1 OF 8 SHEETS

F.A.I. RTE.	SECTION	COUNTY	TOTAL SHEETS	SHEET NO.
280	(81-18)RR	ROCK ISLAND	24	17
CONTRACT NO. 64L93				
ILLINOIS FED. AID PROJECT				

TABLE A

Pier	Span	Girder	Brg. Stiffener	Bottom Flange	Repair	L	No. Req'd.
3	3	A, B, J, & K	5/8" x 5 1/2"	1" x 12"	A	5 1/2"	16
3	3	C & H	5/8" x 5 1/2"	1" x 12"	A	1'-3 1/2"	8
3	3	D, E, F, & G	5/8" x 5 1/2"	1" x 12"	A	1'-0 8/16"	16
3	4	A, B, J, & K	5/8" x 5 1/2"	1" x 12"	A	5 1/2"	16
3	4	C & H	5/8" x 5 1/2"	1" x 12"	A	1'-3 1/2"	8
3	4	D, E, F, & G	5/8" x 5 1/2"	1" x 12"	A	1'-0 8/16"	16
7	7	F	5/8" x 5 1/2"	1" x 12"	A	1'-3 1/2"	4
7	8	C & H	3/4" x 7 1/2"	7/8" x 16"	B	1'-6 7/8"	8
7	8	F & G	3/4" x 7 1/2"	7/8" x 16"	B	1'-3 1/2"	8
10	10	J	3/4" x 7 1/2"	7/8" x 16"	B	5 1/2"	4
10	10	C, D, H, & G	3/4" x 7 1/2"	7/8" x 16"	B	1'-6 7/8"	16
10	10	F	3/4" x 7 1/2"	7/8" x 16"	B	1'-3 1/2"	4
10	11	C, G, & H	3/4" x 7 1/2"	7/8" x 16"	B	1'-6 7/8"	12
17	17	B	7/8" x 7 1/2"	1" x 16"	B	5 1/2"	4
17	17	C & D	7/8" x 7 1/2"	1" x 16"	B	1'-6 7/8"	8
17	17	E & F	7/8" x 7 1/2"	1" x 16"	B	1'-3 1/2"	8
17	18	C, D, & H	3/4" x 7 1/2"	7/8" x 16"	B	1'-6 7/8"	12
20	20	A, B, J, & K	3/4" x 7 1/2"	7/8" x 16"	B	5 1/2"	16
20	20	C & H	3/4" x 7 1/2"	7/8" x 16"	B	1'-6 7/8"	8
20	20	D, E, F, & G	3/4" x 7 1/2"	7/8" x 16"	B	1'-3 1/2"	16
20	21	A, B, J, & K	5/8" x 5 1/2"	1" x 12"	A	5 1/2"	16
20	21	C & H	5/8" x 5 1/2"	1" x 12"	A	1'-6 7/8"	8
20	21	D, E, F, & G	5/8" x 5 1/2"	1" x 12"	A	1'-3 1/2"	16
24	24	A, B, J, & K	5/8" x 5 1/2"	1" x 12"	A	5 1/2"	16
24	24	C & H	5/8" x 5 1/2"	1" x 12"	A	1'-3 1/2"	8
24	24	D, E, F, & G	5/8" x 5 1/2"	1" x 12"	A	1'-0 8/16"	16
24	25	A, B, J, & K	5/8" x 5 1/2"	1" x 12"	A	5 1/2"	16
24	25	C & H	5/8" x 5 1/2"	1" x 12"	A	1'-3 1/2"	8
24	25	D, E, F, & G	5/8" x 5 1/2"	1" x 12"	A	1'-0 8/16"	16

GENERAL NOTES

All structural steel shall conform to AASHTO Classification M-270 Gr. 36, unless otherwise noted.
 Plan dimensions and details relative to existing plans are subject to nominal construction variations. The Contractor shall field verify existing dimensions and details affecting new construction and make necessary approved adjustments prior to construction or ordering of materials. Such variations shall not be cause for additional compensation for a change in scope of the work, however, the Contractor will be paid for the quantity actually furnished at the unit price bid for the work.
 Reinforcement bars designated (E) shall be epoxy coated.
 Cost of removal and re-installation of all members necessary to complete the work as detailed on the plans and as specified in the Special Provisions shall be included with Structural Steel Repair.
 Joint openings shall be adjusted according to Article 520.04 of the Std. Specs. when the deck is poured at an ambient temperature other than 50° F.
 Fasteners shall be high strength bolts. Bolts 3/4"φ, open holes 13/16"φ, unless otherwise noted.

The existing structural steel coating contains lead. The Contractor shall take appropriate precautions to deal with the presence of lead on this project.
 All structural steel shall be shop painted with the inorganic zinc rich primer per AASHTO M300, Type 1. Cost included with Structural Steel Repair.
 Existing structural steel that will be in contact with new structural steel shall be cleaned and painted prior to erection as required by the Special Provision "Cleaning and Painting Contact Surface Areas of Existing Steel Structures".
 Existing reinforcement bars extending into the removal area shall be cleaned, straightened and incorporated into the new construction. Any reinforcement bars that are damaged during concrete removal shall be replaced with an approved bar splicer or anchorage system. Cost included with Concrete Removal.
 The deck surface shall have its final finish tined according to Article 420.09(e)(1) of the Standard Specifications. Cost included with Concrete Superstructure.
 No field welding is permitted except as specified in the contract documents.

LEGEND

- Holes to be field drilled in existing steel using new steel as template.
- Holes to be field drilled in new steel using existing holes as template.

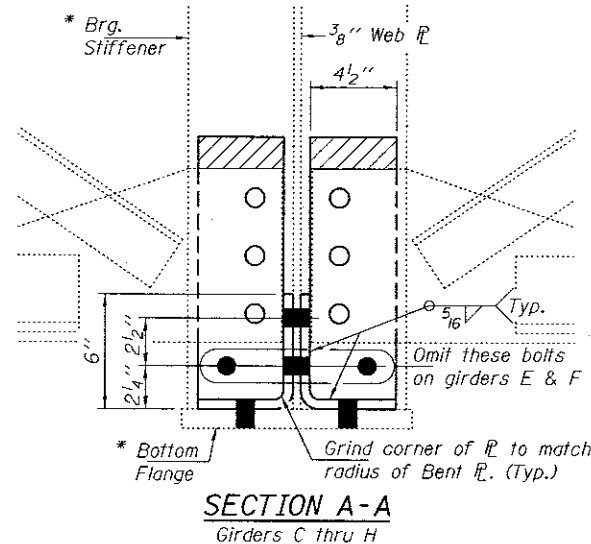

SECTION A-A
Girders C thru H

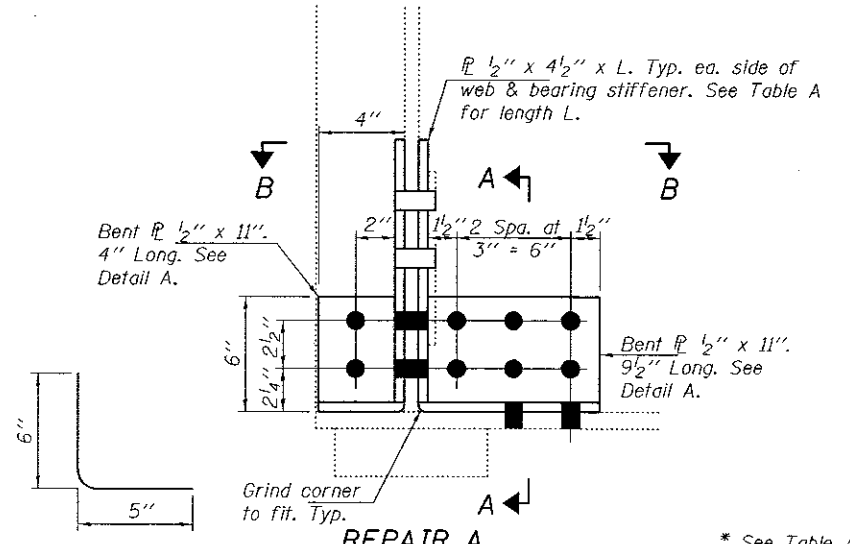

REPAIR A

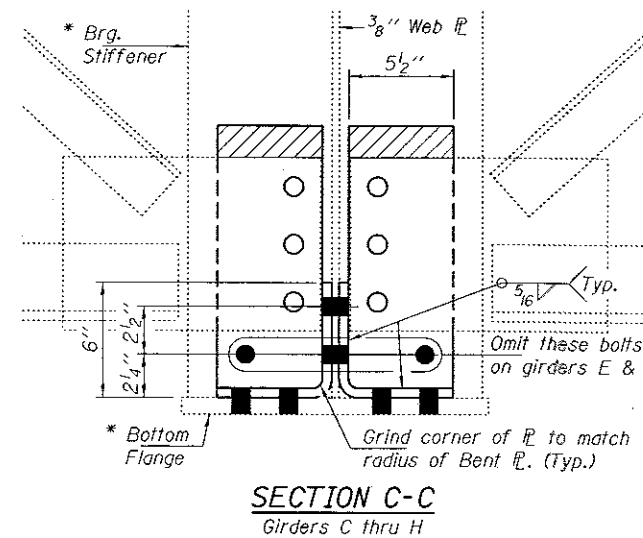

SECTION C-C
Girders C thru H

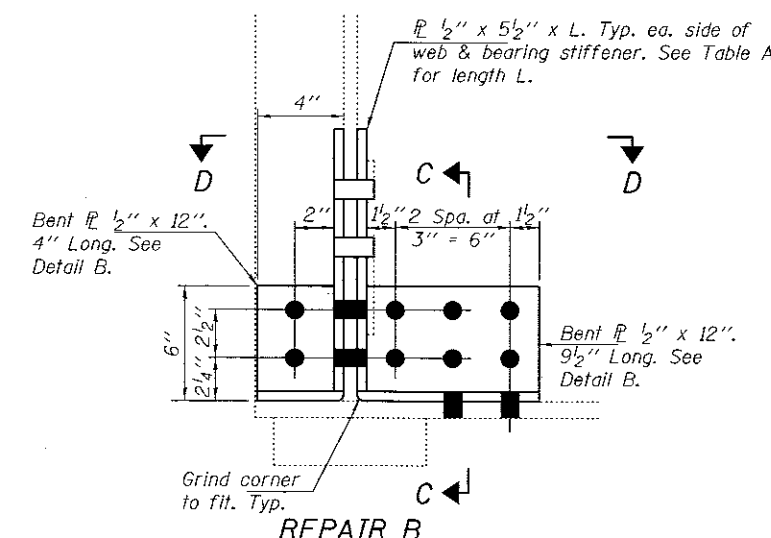

REPAIR B

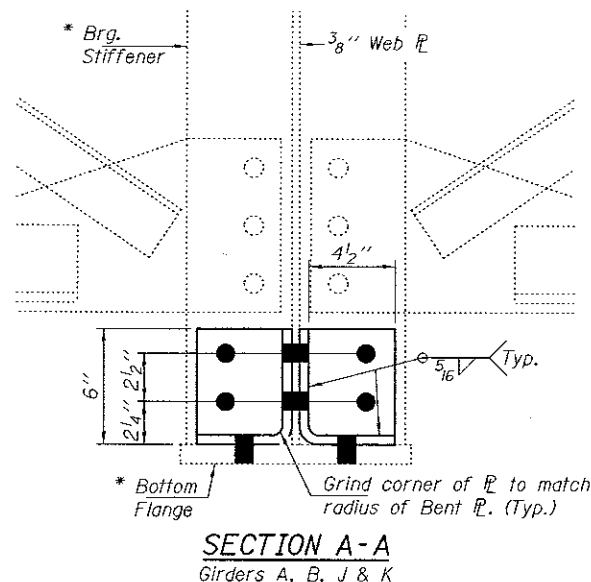

SECTION A-A
Girders A, B, J & K

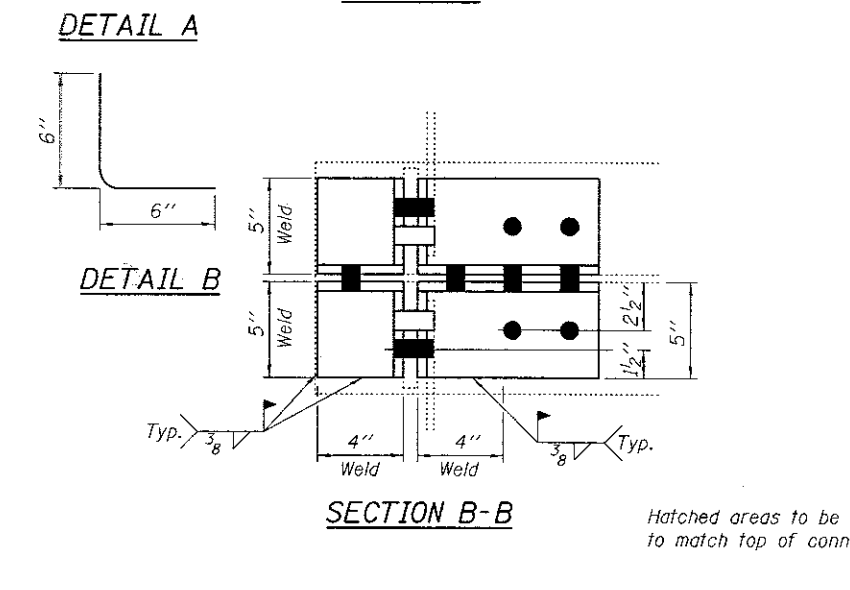

SECTION B-B

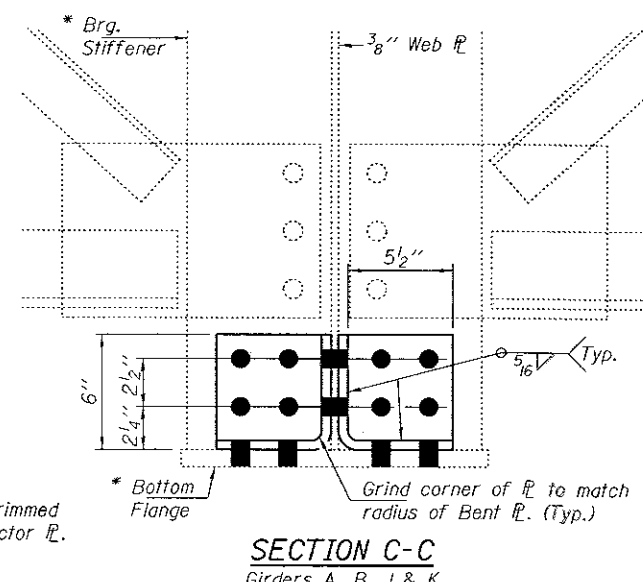

SECTION C-C
Girders A, B, J & K

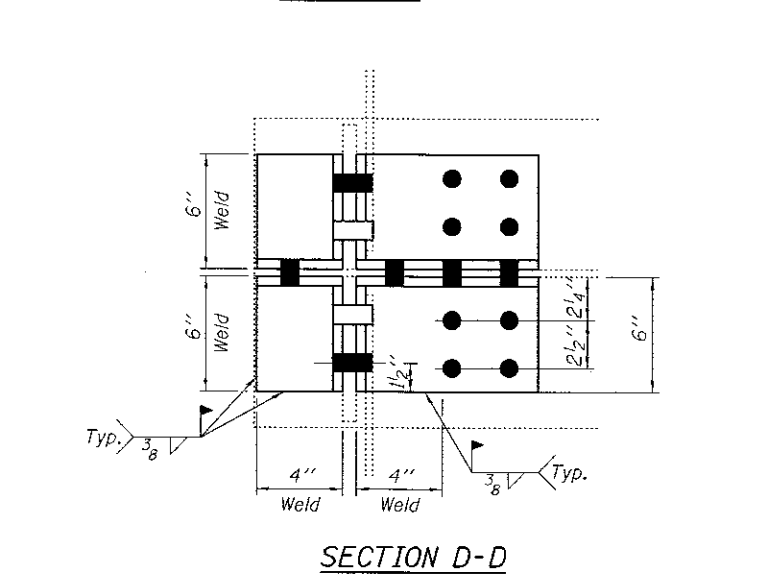

SECTION D-D

Hatched areas to be trimmed to match top of connector flange.

DESIGNED RPN	EXAMINED <i>Timothy A. Mallett</i>	DATE JANUARY 16, 2018
CHECKED MLD	ENGINEER OF STRUCTURAL SERVICES	
DRAWN balva	PASSED <i>Carl Pappas</i>	REVISOR
CHECKED RPN MLD	ENGINEER OF BRIDGES AND STRUCTURES	REVISION

STATE OF ILLINOIS
DEPARTMENT OF TRANSPORTATION

GENERAL NOTES & BEAM END REPAIRS
SN 081-0106

F.A.I. RTE. 280	SECTION 6L-IBRRR	COUNTY ROCK ISLAND	TOTAL SHEETS 24	SHEET NO. 18
CONTRACT NO. 64L93			ILLINOIS FED. AID PROJECT	

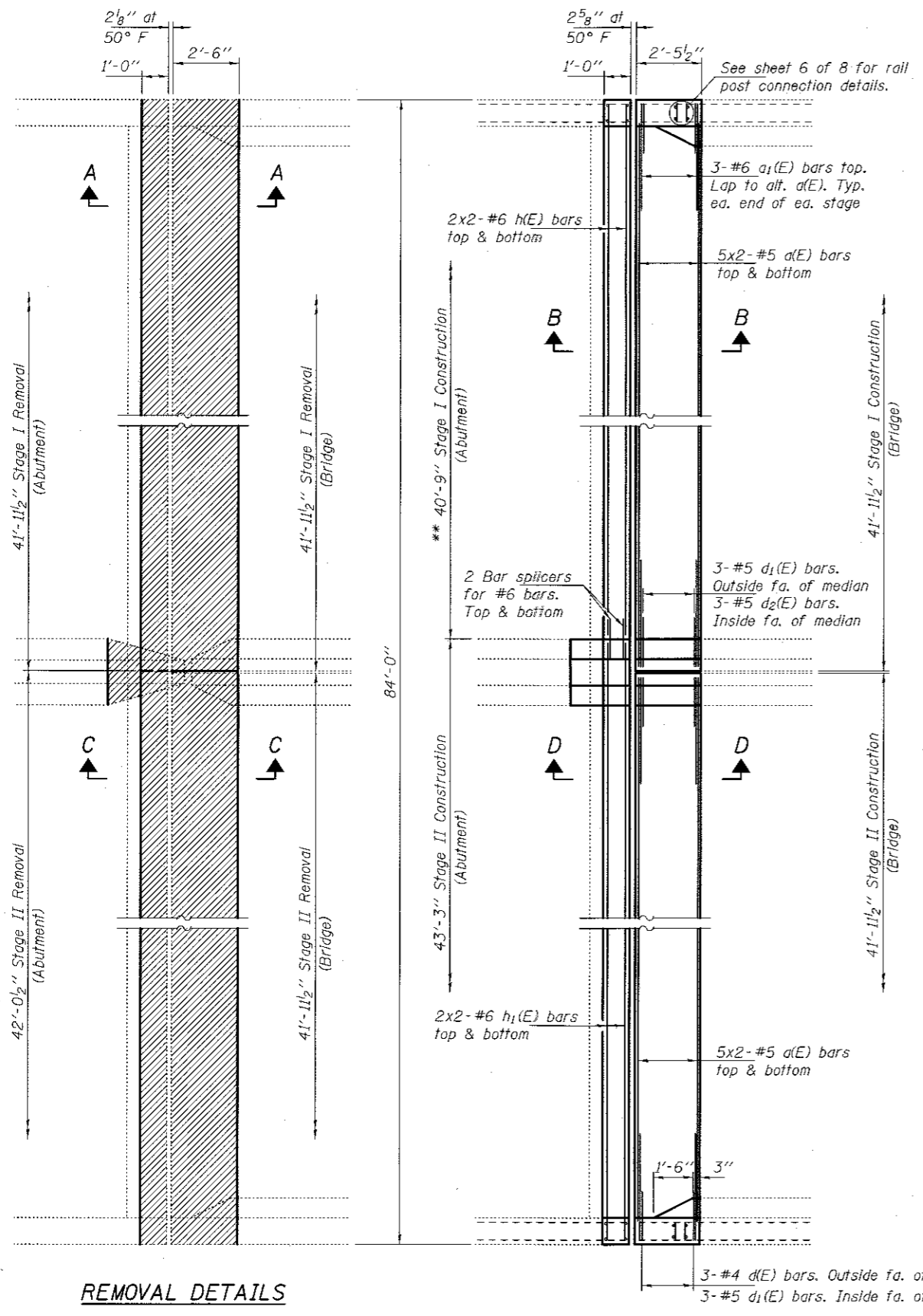

REMOVAL DETAILS

REPLACEMENT DETAILS

Hatched areas indicate removal

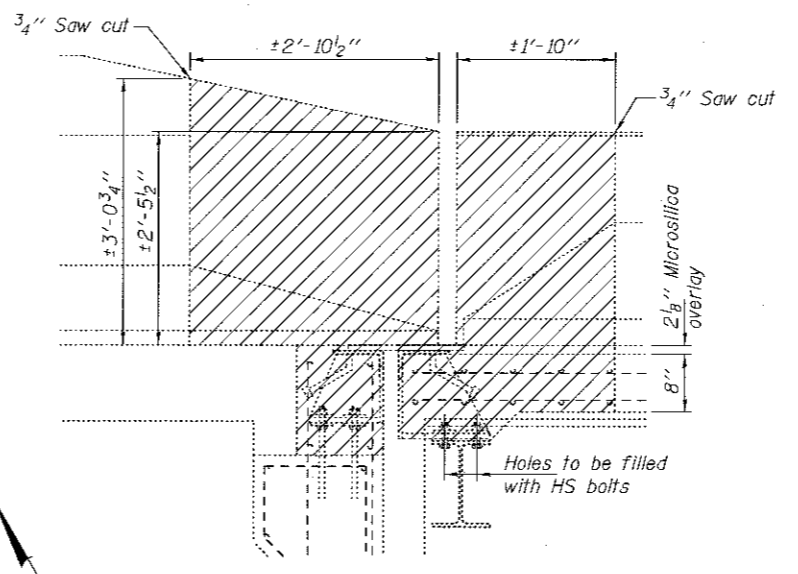

SECTION C-C

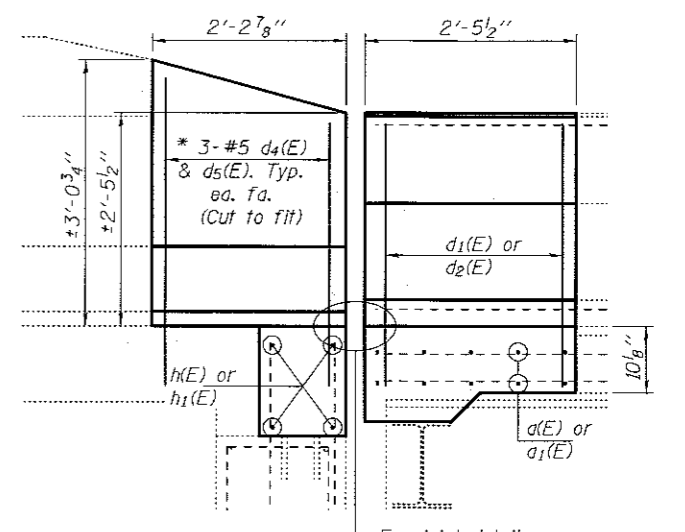

SECTION D-D

For joint details, see sheet 7 of 8.

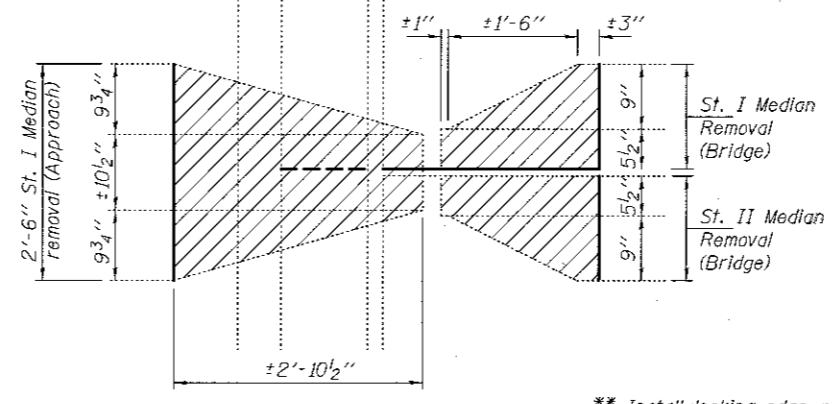

MEDIAN REMOVAL PLAN

Median on West approach to be removed with Stage I & rebuilt with Stage II.

* Epoxy grout d4(E) & d5(E) bars in 9" min. holes according to Article 584 of the Standard Specifications.

MIN. BAR LAPS
 #5 Bar - 3'-6"
 #6 Bar - 4'-0"

** Install locking edge rail full length in Stage I Construction (Abutment side)

MEDIAN CONSTRUCTION PLAN

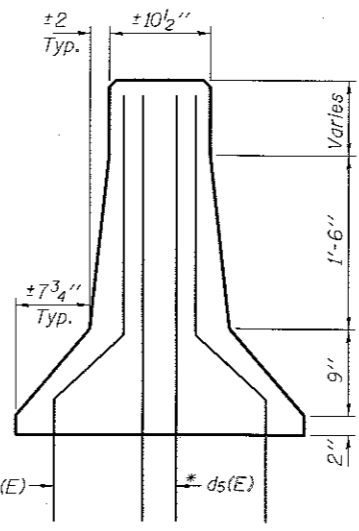

SECTION THRU APPROACH MEDIAN

(Match existing dimensions)

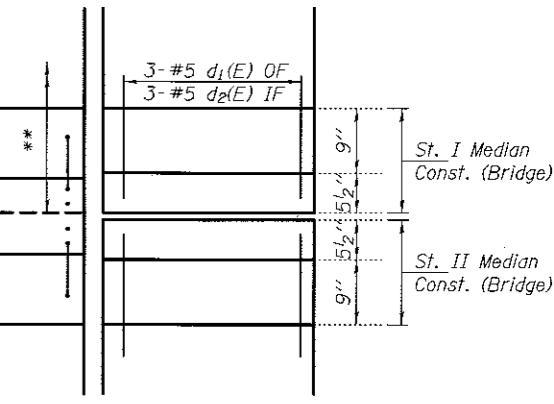

SECTION THRU BRIDGE MEDIAN

(Match existing dimensions)

For Sections A-A and B-B, reinforcement details and Bill of Material, see sheet 5 of 8.

DESIGNED RPN	EXAMINED <i>Timothy A. Alty</i>	DATE JANUARY 16, 2018
CHECKED MLD	ENGINEER OF STRUCTURAL SERVICES	
DRAWN <i>baliva</i>	PASSED <i>Carl Perry</i>	REVISOR
CHECKED RPN MLD	ENGINEER OF BRIDGES AND STRUCTURES	REVISOR

STATE OF ILLINOIS
DEPARTMENT OF TRANSPORTATION

WEST ABUTMENT REPAIR DETAILS
SN 081-0106

SHEET NO. 3 OF 8 SHEETS

F.A.I. RTE. 280	SECTION (81-16)BR	COUNTY ROCK ISLAND	TOTAL SHEETS 24	SHEET NO. 19
CONTRACT NO. 64L93				
ILLINOIS FED. AID PROJECT				

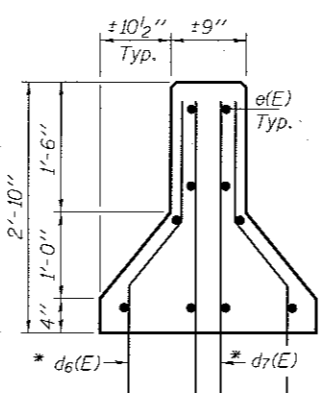
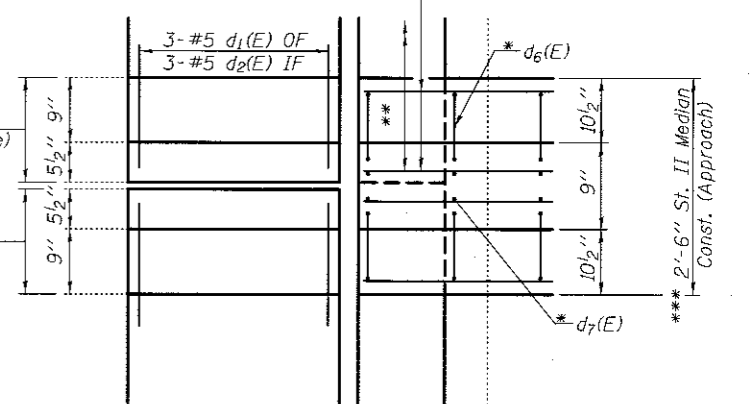
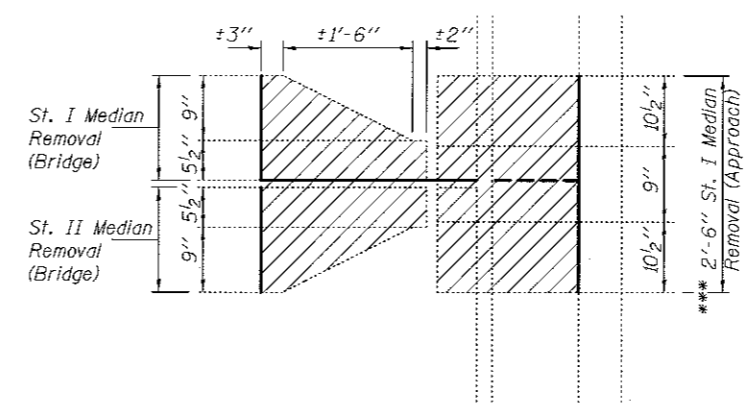
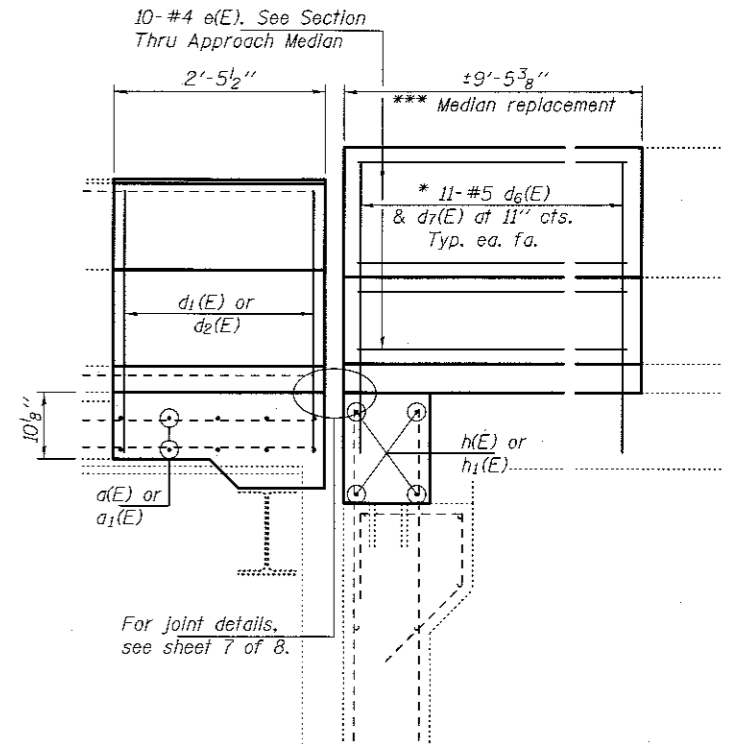
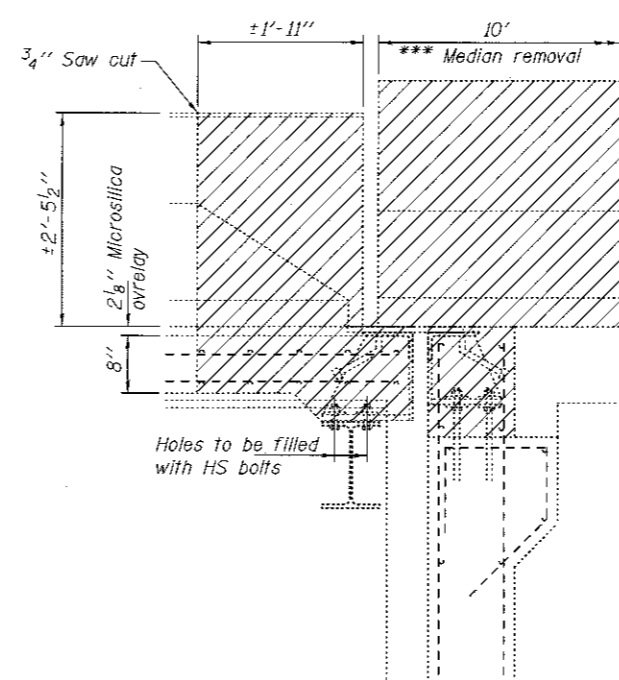
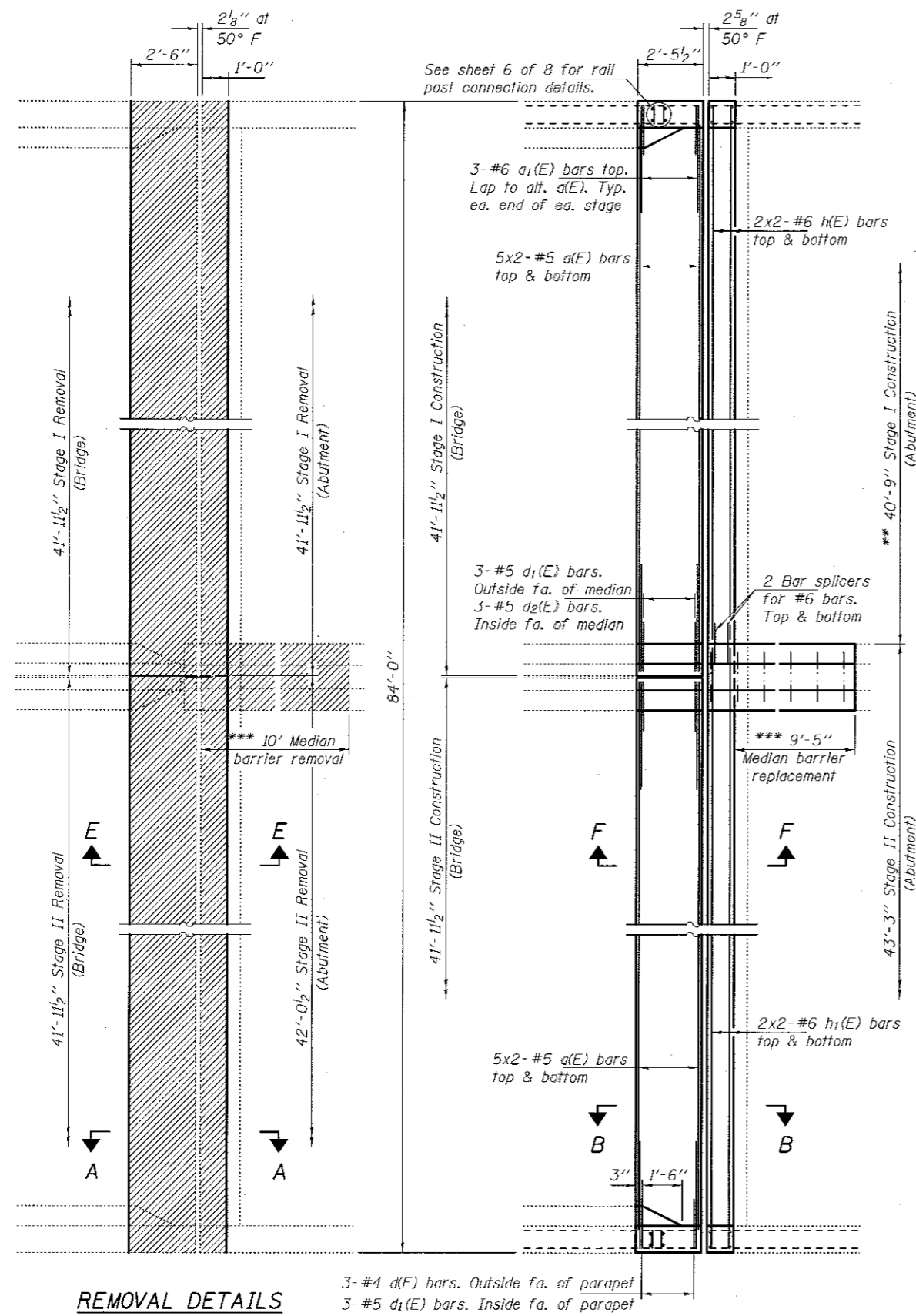

*** 10' section of East approach median barrier to be removed with Stage I & rebuilt with Stage II as detailed.

MIN. BAR LAPS
 #5 Bar - 3'-6"
 #6 Bar - 4'-0"

* Epoxy grout $d_6(E)$ & $d_7(E)$ bars in 9" min. holes according to Article 584 of the Standard Specifications.

For Sections A-A and B-B, reinforcement details and Bill of Material, see sheet 5 of 8.
 For Section thru bridge median, see sheet 3 of 8.

DESIGNED RPN	EXAMINED <i>Timothy A. ...</i>	DATE JANUARY 16, 2018
CHECKED MLD	ENGINEER OF STRUCTURAL SERVICES	
DRAWN boliva	PASSED <i>Carl ...</i>	REVISED
CHECKED RPN MLD	ENGINEER OF BRIDGES AND STRUCTURES	REVISED

STATE OF ILLINOIS
 DEPARTMENT OF TRANSPORTATION

EAST ABUTMENT REPAIR DETAILS
 SN 081-0106
 SHEET NO. 4 OF 8 SHEETS

F.A.I. RTE. 280	SECTION 181-1B/RRR	COUNTY ROCK ISLAND	TOTAL SHEETS 24	SHEET NO. 20
CONTRACT NO. 64L93				
ILLINOIS FED. AID PROJECT				

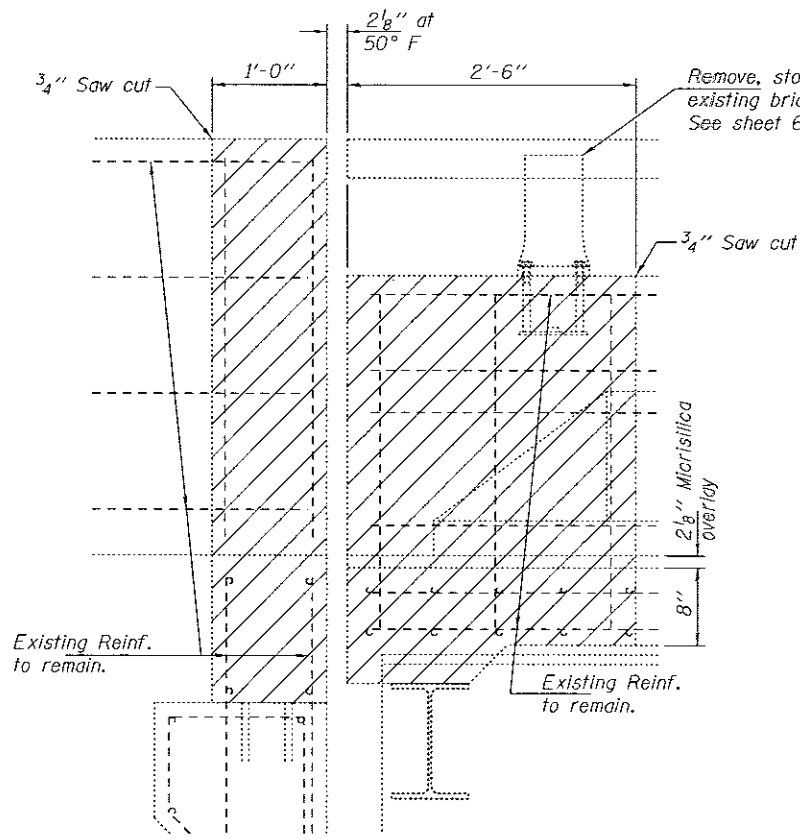

SECTION A-A
Hatched areas indicate removal.

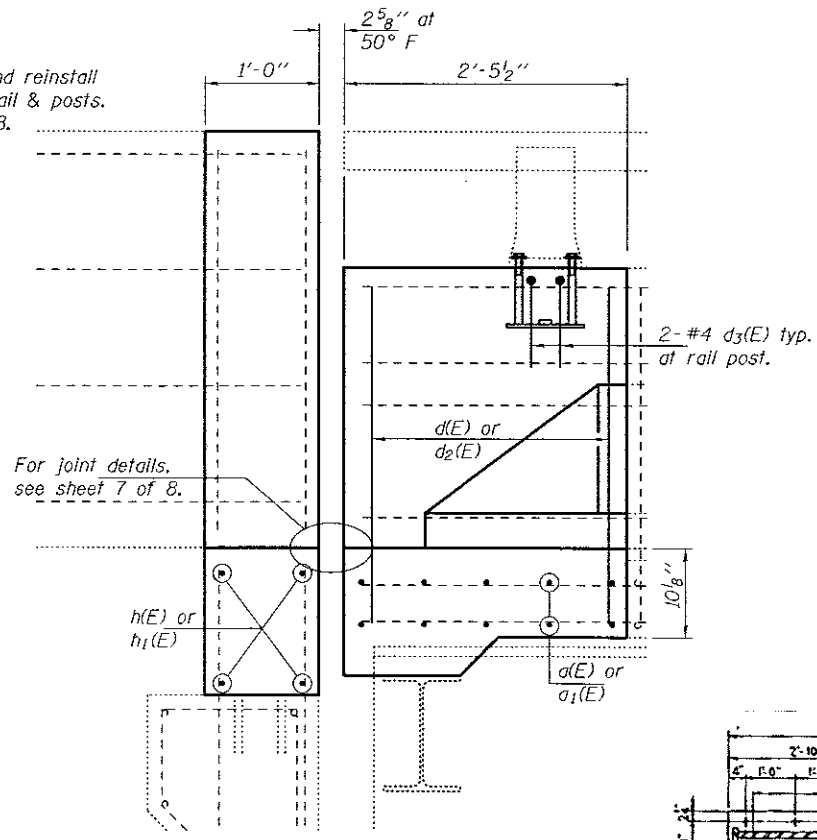

SECTION B-B

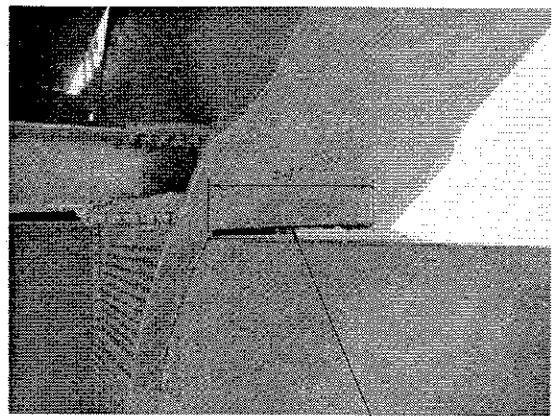

REPAIR G

Caulk & seal gap. See Article 109.04 of the Standard Specifications.

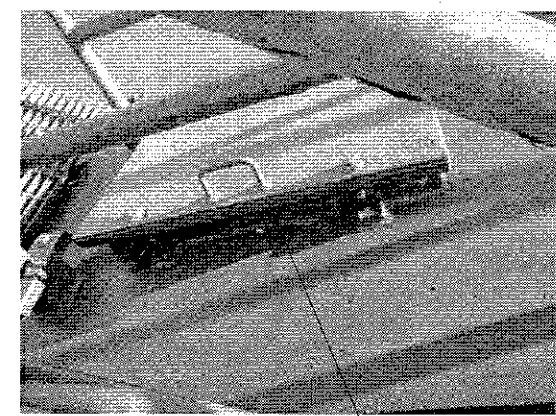

REPAIR H

Clean & paint access door. See Article 109.04 of the Standard Specifications.

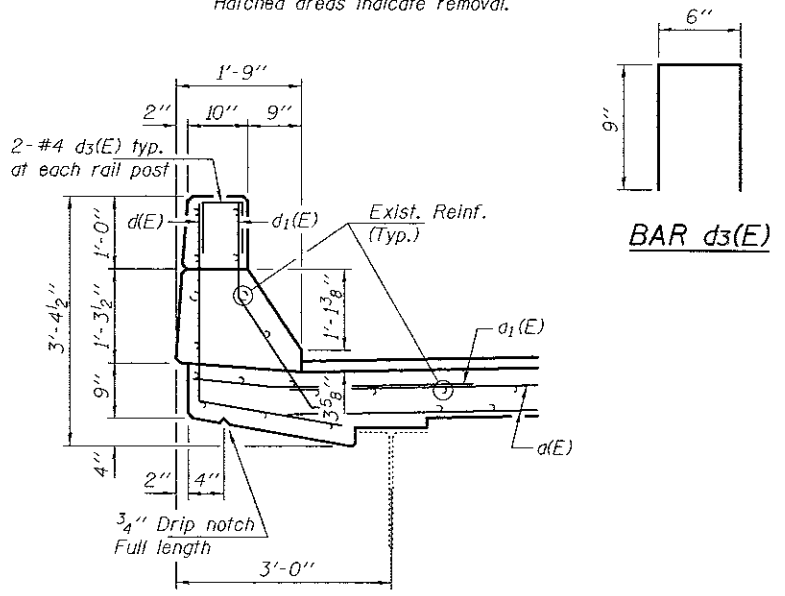

TYPICAL OUTSIDE PARAPET SECTION

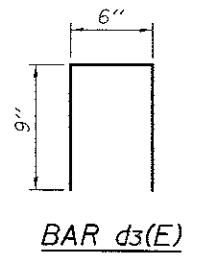

BAR d3(E)

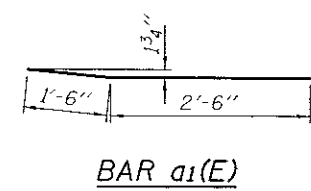

BAR a1(E)

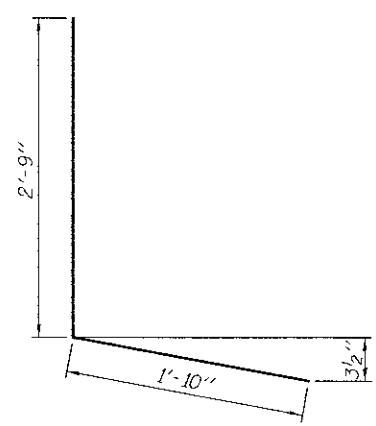

BAR d(E)

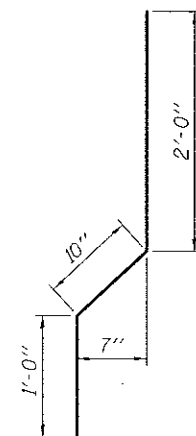

BAR d4(E)

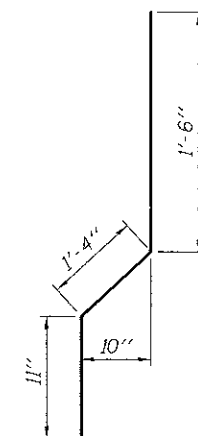

BAR d6(E)

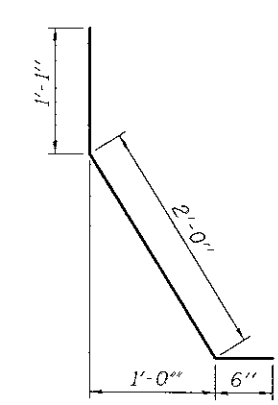

BAR d1(E)

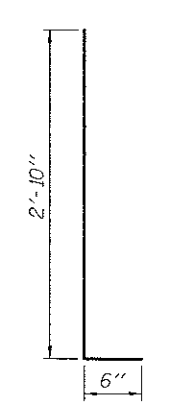

BAR d2(E)

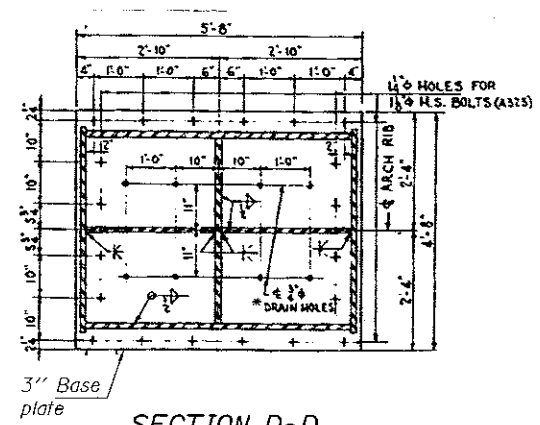

SECTION D-D

* Unclog. See Article 109.04 of the Standard Specifications.

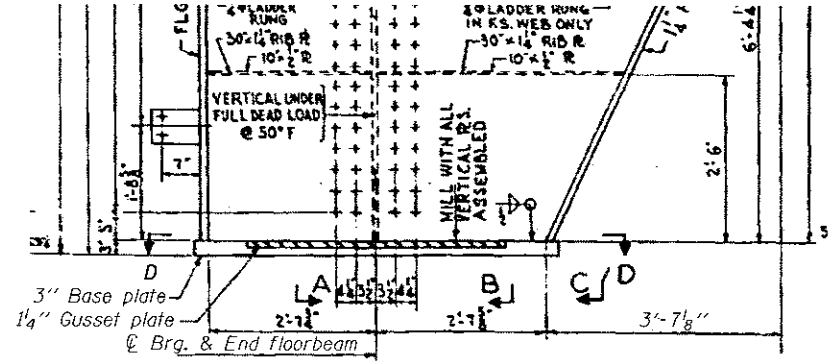

PARTIAL ELEVATION

REPAIR I

BILL OF MATERIAL

Bar	No.	Size	Length	Shape
d(E)	80	#5	22'-3"	
a1(E)	24	#6	4'-0"	
d(E)	12	#4	4'-7"	
d1(E)	24	#5	3'-7"	
d2(E)	12	#5	3'-4"	
d3(E)	8	#4	2'-0"	
d4(E)	6	#5	3'-10"	
d5(E)	6	#5	3'-8"	
d6(E)	22	#5	3'-9"	
d7(E)	22	#5	3'-6"	
e(E)	10	#4	9'-2"	
h(E)	16	#6	22'-3"	
h1(E)	16	#6	23'-6"	
Concrete Removal			Cu. Yd.	27.6
Concrete Superstructure			Cu. Yd.	28.8
Reinforcement Bars, Epoxy Coated			Lbs.	3560

DESIGNED RPN
 CHECKED MLD
 DRAWN baliva
 CHECKED RPN MLD

EXAMINED *Timothy A. Ancelet*
 ENGINEER OF STRUCTURAL SERVICES

DATE JANUARY 16, 2018

REVISOR
 REVISOR

ENGINEER OF BRIDGES AND STRUCTURES

STATE OF ILLINOIS
 DEPARTMENT OF TRANSPORTATION

TROUGH REPLACEMENT DETAILS
 SN 081-0106

SHEET NO. 5 OF 8 SHEETS

F.A.I. RT.E. 280
 SECTION 081-1B18R
 COUNTY ROCK ISLAND
 TOTAL SHEETS 24
 SHEET NO. 21
 CONTRACT NO. 64L93
 ILLINOIS FED. AID PROJECT

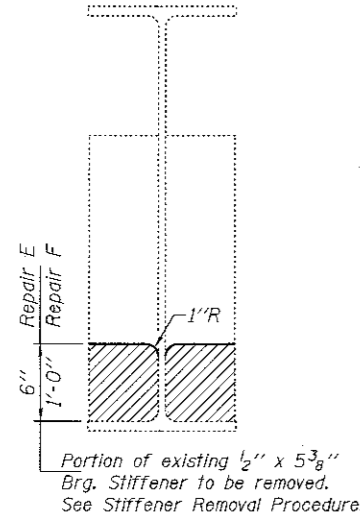

EXISTING END SECTION

Hatched area indicates Web Stiffener Removal (Cost included with Structural Steel Repair)

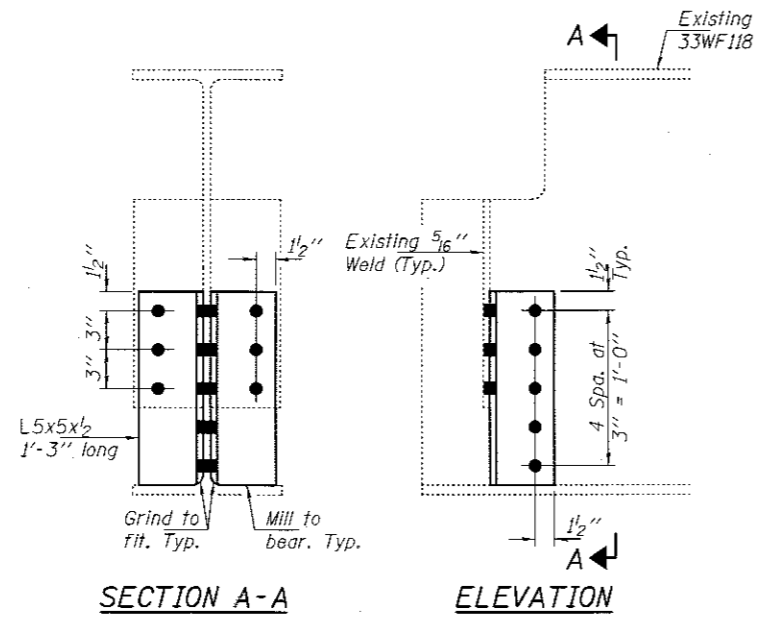

SECTION A-A

ELEVATION

REPAIR E

See sheet 1 of 8 for locations.

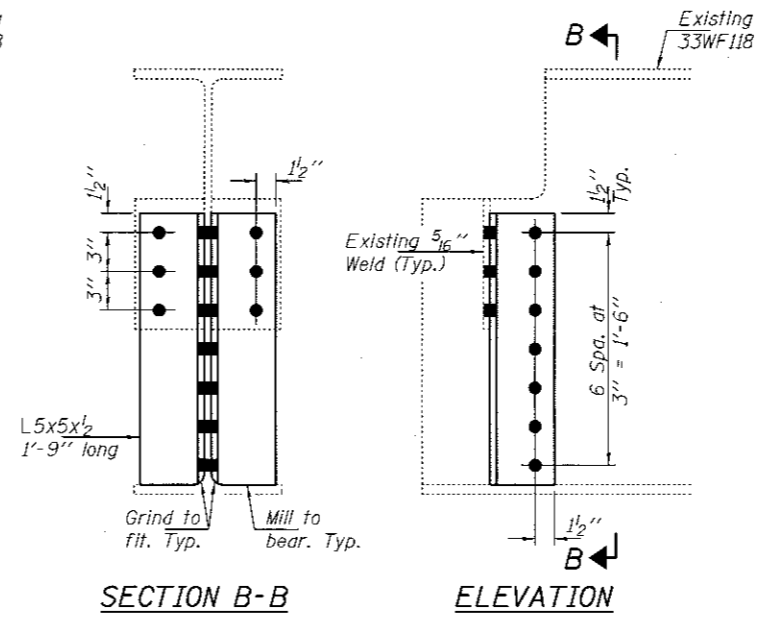

SECTION B-B

ELEVATION

REPAIR F

See sheet 1 of 8 for location.

STIFFENER REMOVAL PROCEDURE

1. Cut existing web stiffener as shown. The minimum distance from cut to face of web shall be the larger of 1/4 inch or web to plate weld size, with removal of remaining material by grinding as described below. The cut shall be made parallel to the web without angling the cut towards the web. Equipment and method of cutting shall be approved by the Engineer. Any method of removal to be used shall ensure that no damage is done to the existing web. Cutting shall be done in a manner such that the paint on the opposite face of the web is not damaged. If damage occurs, the damaged area shall be repainted at the contractor's expense and procedures shall be modified to prevent damage at subsequent removal locations.
2. Remove material between cut and web by grinding and grind smooth at web surface and cut end of stiffener. Web R_e surfaces and cut end of stiffener shall have a roughness average (Ra) of 250 μ in. or less. Grinding equipment shall be approved by the Engineer. The grinding operation should not gouge the girder web R_e .
3. The web surface at the modification shall be inspected using dye penetrant or magnetic particle (MT) methods. Any cracks found shall be identified and reported to the Bureau of Bridges and Structures for further disposition.

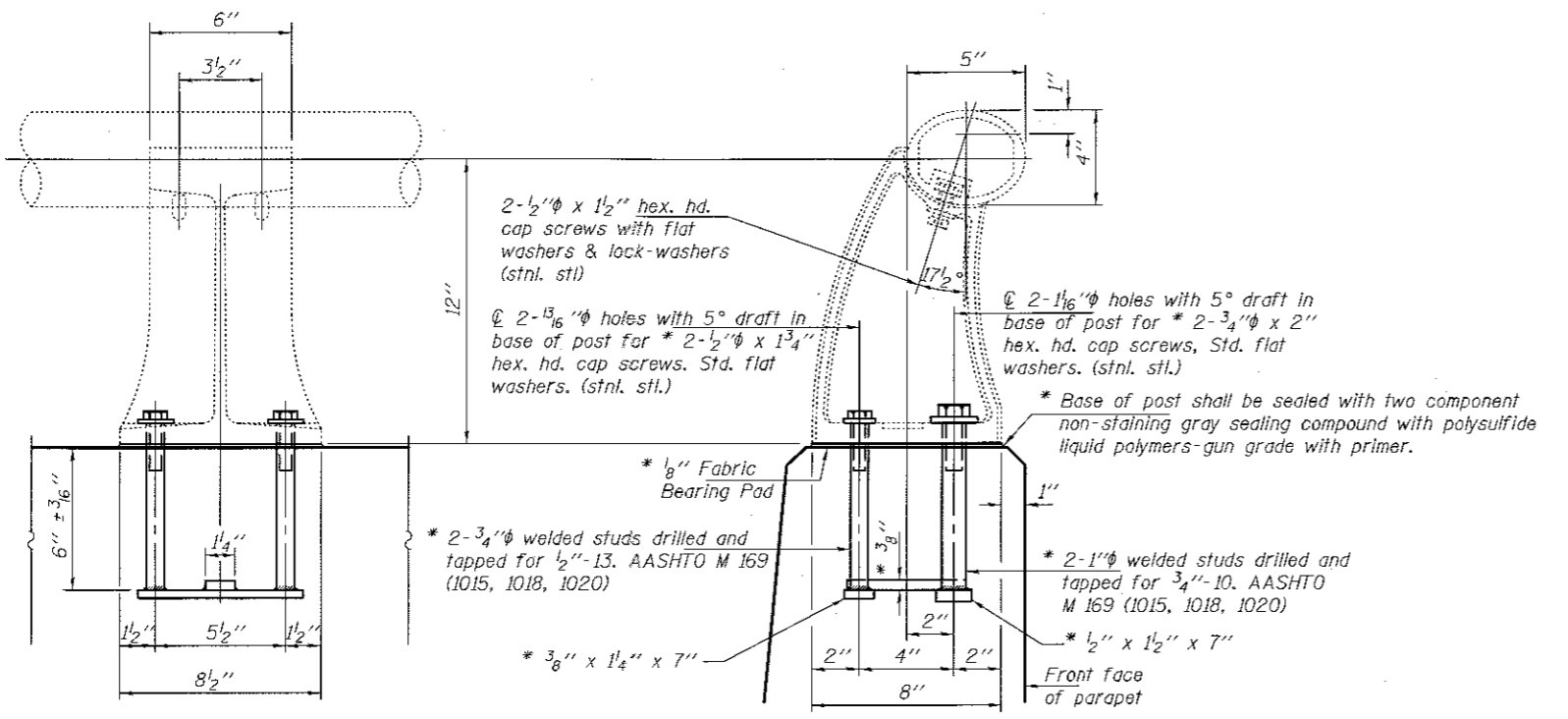

RAIL POST DETAILS

* New Rail Post anchorage devices will be required at each location where posts are connected to new construction. Cost included with Concrete Superstructure.

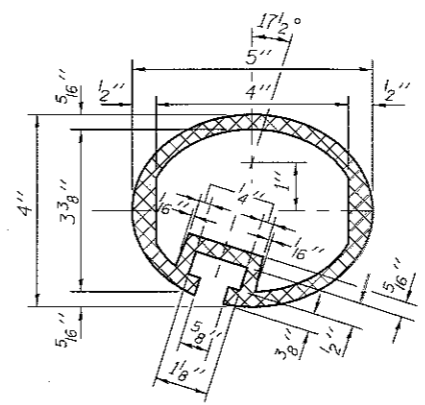

SEC. THRU ELLIPTICAL RAIL SECTION

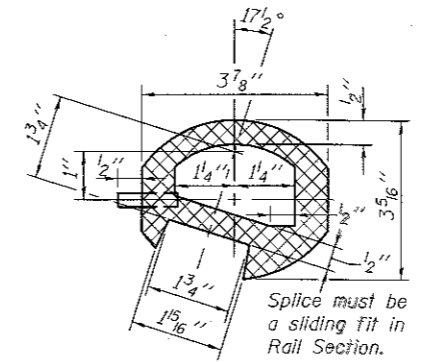

SEC. THRU SPLICE

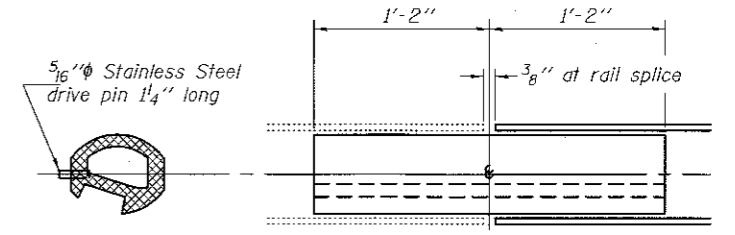

RAIL SPLICE

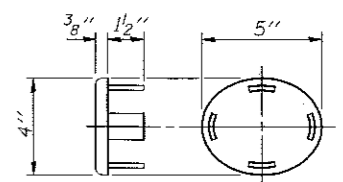

CAST END CAP DRIVE FIT TYPE

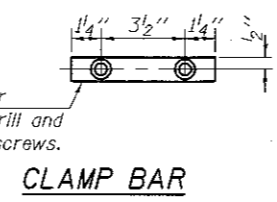

CLAMP BAR

DESIGNED RPN	EXAMINED Timothy A. Meltzer	DATE JANUARY 16, 2018	STATE OF ILLINOIS DEPARTMENT OF TRANSPORTATION	ALUMINUM RAILING REPAIR DETAILS SN 081-0106	F.A.I. RTE.	SECTION	COUNTY	TOTAL SHEETS	SHEET NO.
CHECKED MLD	ENGINEER OF STRUCTURAL SERVICES				280	(61-18)BRR	ROCK ISLAND	24	22
DRAWN baliva	PASSED J. Carl Perry	REVIS			CONTRACT NO. 64L93				
CHECKED RPN MLD	ENGINEER OF BRIDGES AND STRUCTURES	REVIS			ILLINOIS FED. AID PROJECT				
				SHEET NO. 6 OF 8 SHEETS					

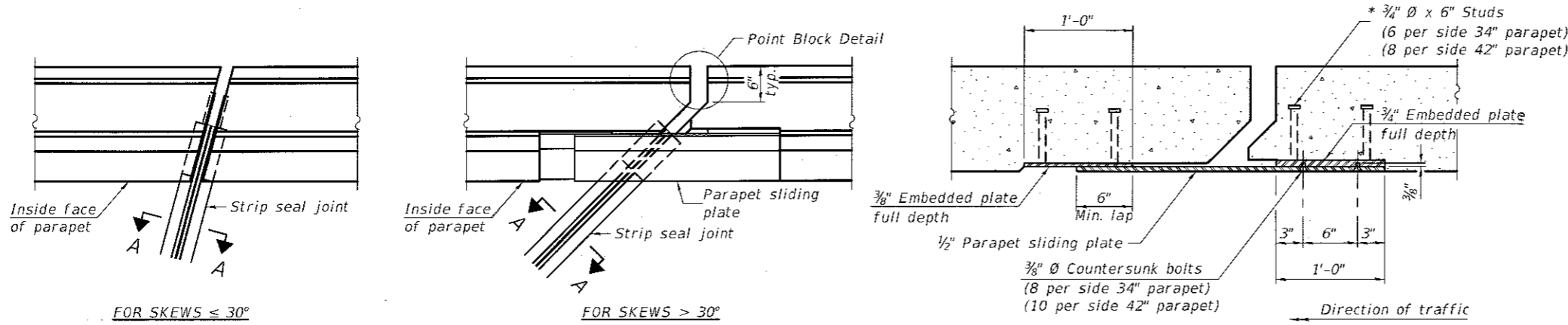

PLAN AT PARAPET

SECTION B-B

Notes:
 The strip seal shall be made continuous and shall have a minimum thickness of 1/4". The configuration of the strip seal shall match the configuration of the locking edge rails. Open or "webbed" strip seal gland configurations are not permitted. The gland shall be sized for a maximum rated movement of 4 inches.
 The locking edge rails depicted are configured for typical applications and are conceptual only. The actual configuration of the locking edge rails and matching strip seal may vary from manufacturer to manufacturer provided they fit the application and meet the minimum anchorage shown. Flanged edge rails, however, will not be allowed. Locking edge rails may exceed the 4 1/2" maximum depth provided the anchorage system is revised according to the manufacturer's recommendation.
 The manufacturer's recommended installation methods shall be followed.

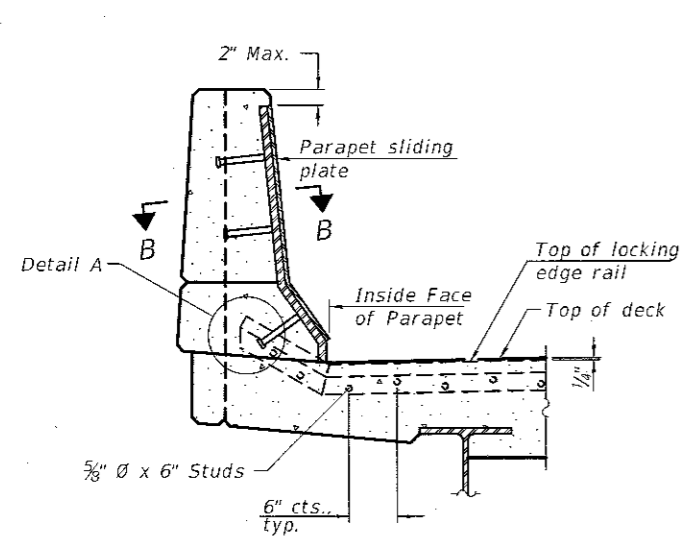

ELEVATION AT PARAPET

Typical except as noted
 (Skews > 30° shown. Skews ≤ 30° similar except as shown in plan view.)

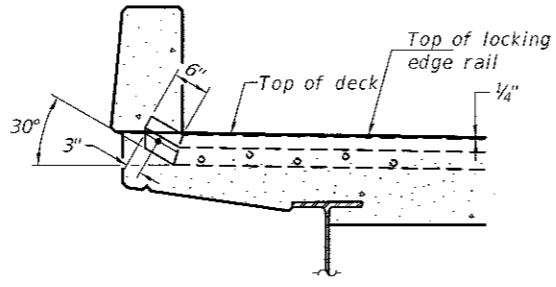

ELEVATION AT OUTSIDE PARAPET

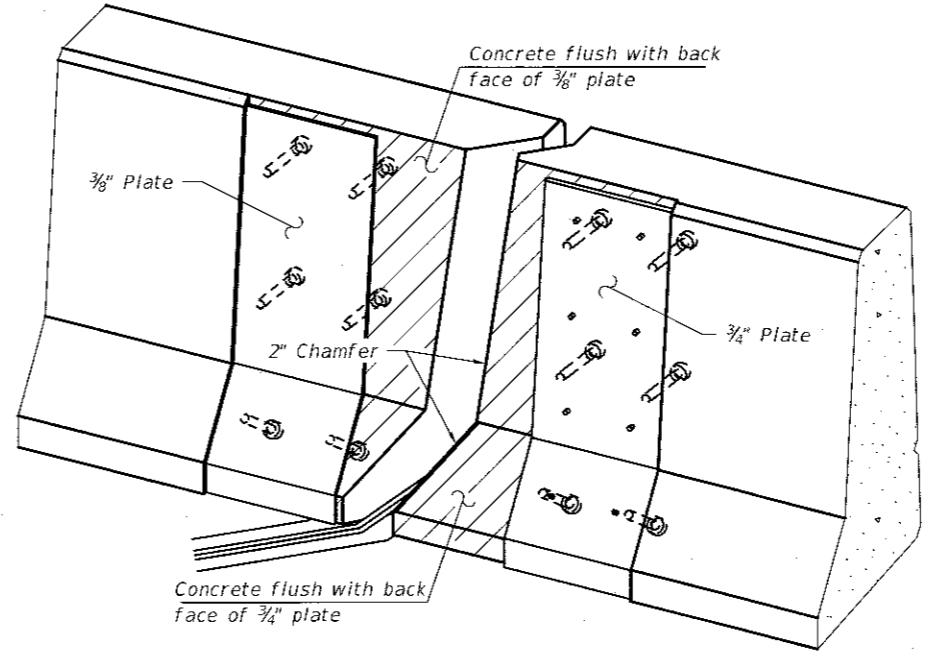

TRIMETRIC VIEW
 (Showing embedded plates only)

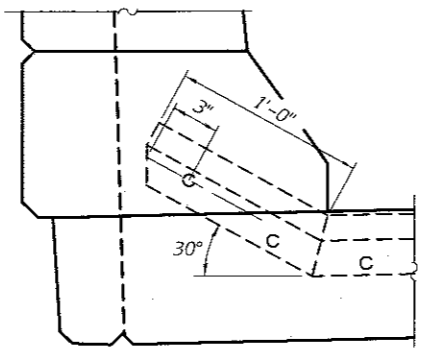

DETAIL A

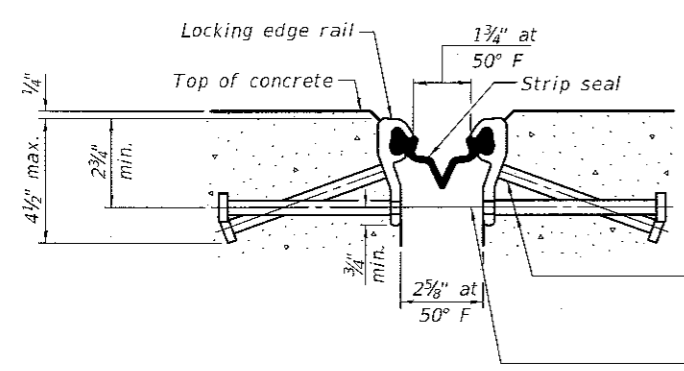

SHOWING ROLLED RAIL JOINT

* 3/8" Ø x 6" studs @ 6" cts. (alternate angled/bent studs with horizontal studs)

3/8" Ø threaded rods in 7/16" Ø holes at ±4'-0" cts. for holding the proper joint opening based on the temperature during the deck pour. Place to miss studs. All rods shall be burned, or sawed off flush with the plates after concrete is set.

SECTION A-A

* Granular or solid flux filled headed studs conforming to Article 1006.32 of the Std. Specs., automatically end welded.

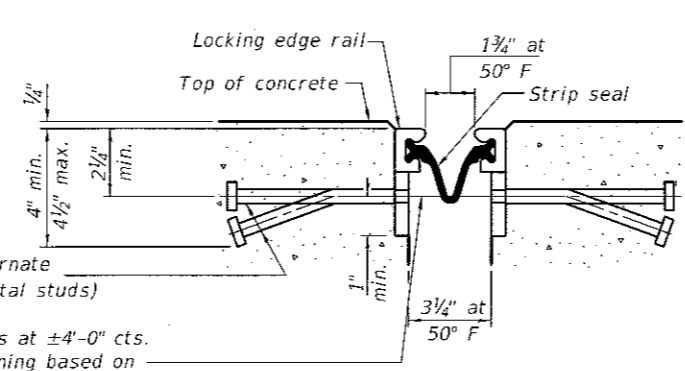

SHOWING WELDED RAIL JOINT

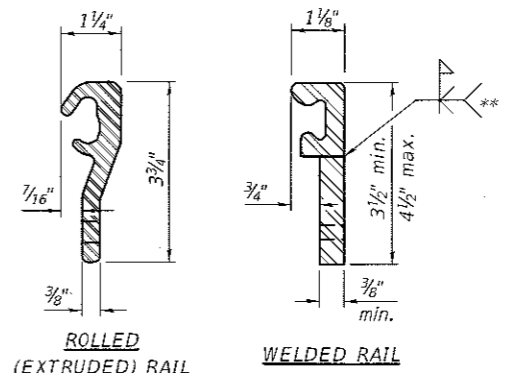

LOCKING EDGE RAILS

** Back gouge not required if complete joint penetration is verified by mock-up.

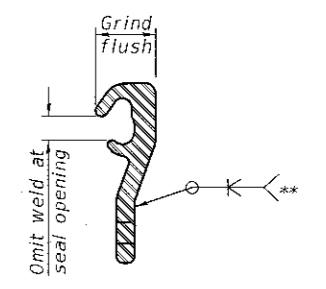

LOCKING EDGE RAIL SPLICE

The inside of the locking edge rail groove shall be free of weld residue. Rolled rail shown, welded rail similar.

BILL OF MATERIAL

Item	Unit	Total
Preformed Joint Strip Seal	Foot	165

8-11-17

DESIGNED RPN	EXAMINED	DATE JANUARY 16, 2018
CHECKED MLD	PASSED	
DRAWN baliva		
CHECKED RPN MLD		

STATE OF ILLINOIS
 DEPARTMENT OF TRANSPORTATION

PREFORMED JOINT STRIP SEAL
 SN 081-0106
 SHEET NO. 7 OF 8 SHEETS

F.A.J. RTE. 280	SECTION (81-1B)BR	COUNTY ROCK ISLAND	TOTAL SHEETS 24	SHEET NO. 23
				CONTRACT NO. 64L93
ILLINOIS FED. AID PROJECT				

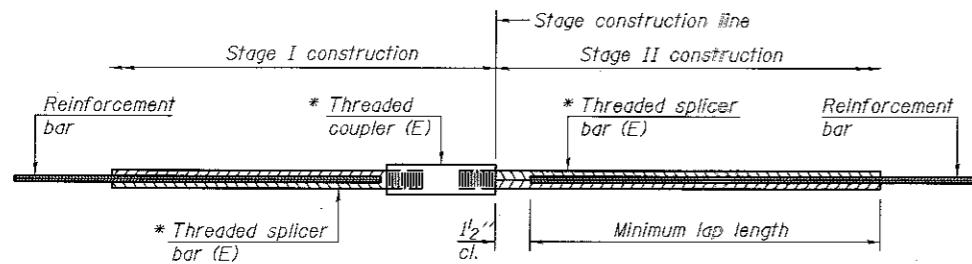

STANDARD BAR SPLICER ASSEMBLY

Threaded splicer bar length = min. lap length + 1/2" + thread length

* Epoxy not required on Bar Splicer Assembly components used in conjunction with black bars.

Location	Bar size	No. assemblies required	Minimum lap length
W. Abut. (HB)	#6	4	4'-0"
E. Abut. (HB)	#6	4	4'-0"

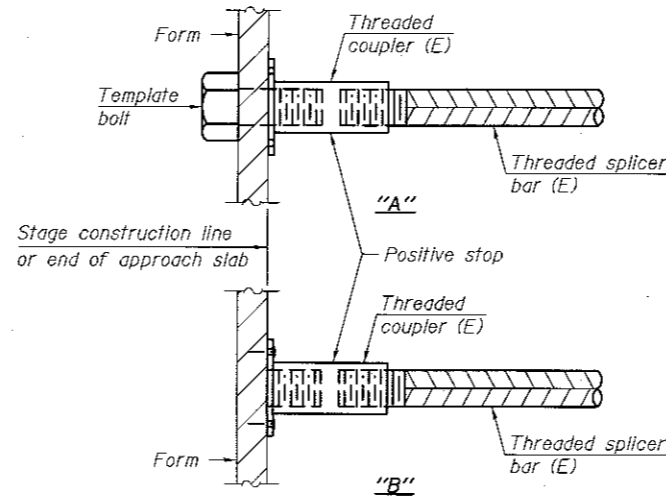

INSTALLATION AND SETTING METHODS

"A" : Set bar splicer assembly by means of a template bolt.

"B" : Set bar splicer assembly by nailing to wood forms or cementing to steel forms.

(E) : Indicates epoxy coating.

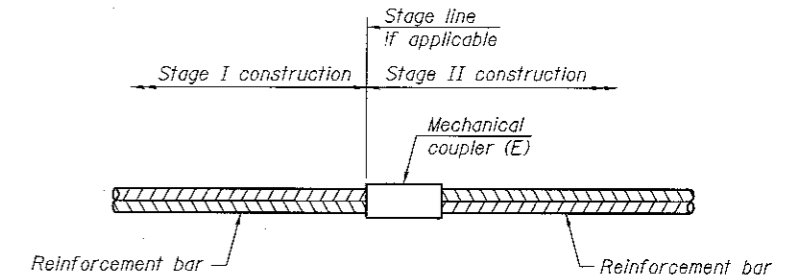

STANDARD MECHANICAL SPLICER

Location	Bar size	No. assemblies required

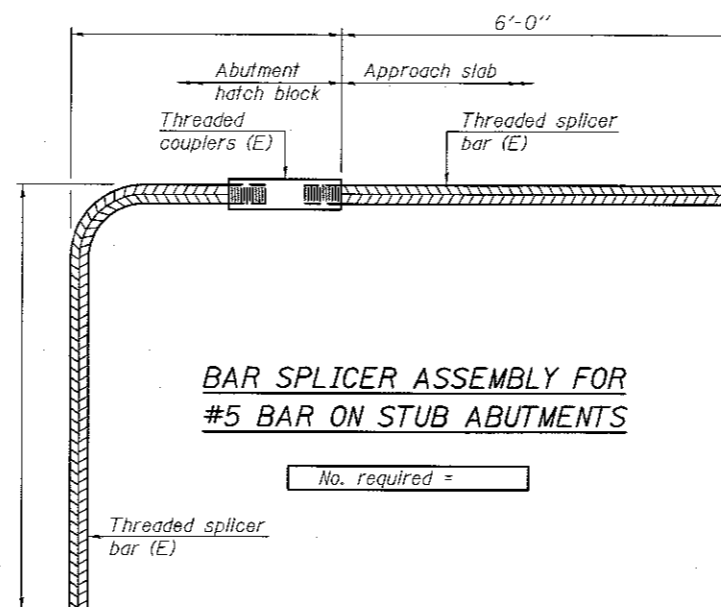

BAR SPLICER ASSEMBLY FOR #5 BAR ON STUB ABUTMENTS

No. required =

NOTES

Splicer bars shall be deformed with threaded ends and have a minimum 60 ksi yield strength.

All reinforcement shall be lapped and tied to the splicer bars. Bar splicer assemblies shall be epoxy coated according to the requirements for reinforcement bars. See Section 508 of the Standard Specifications.

See approved list of bar splicer assemblies and mechanical splicers for alternatives.

BSD-1

6-8-15

DESIGNED RPN	EXAMINED <i>Timothy A. Annett</i>	DATE JANUARY 16, 2018
CHECKED MLD	ENGINEER OF STRUCTURAL SERVICES	
DRAWN baliva	PASSED <i>Carl Perry</i>	REVISED
CHECKED RPN MLD	ENGINEER OF BRIDGES AND STRUCTURES	REVISED

STATE OF ILLINOIS
DEPARTMENT OF TRANSPORTATION

BAR SPLICER ASSEMBLY AND MECHANICAL SPLICER DETAILS
SN 081-0106

SHEET NO. 8 OF 8 SHEETS

F.A.I. RTE.	SECTION	COUNTY	TOTAL SHEETS	SHEET NO.
280	181-18/BRR	ROCK ISLAND	24	24
CONTRACT NO. 64L93			ILLINOIS FED. AID PROJECT	