

STATE OF ILLINOIS
DEPARTMENT OF TRANSPORTATION

ROUTE NO.	SECTION	COUNTY	SHEETS	SHEET NO.	SHEET NO. 53
P.A. U. STATE	①	GRUNDY	50	33	OF 514 SHEETS
FED. ROAD DIST. NO. 7	ILLINOIS	FED. AID PROJECT-			

① G-BR-1 66563

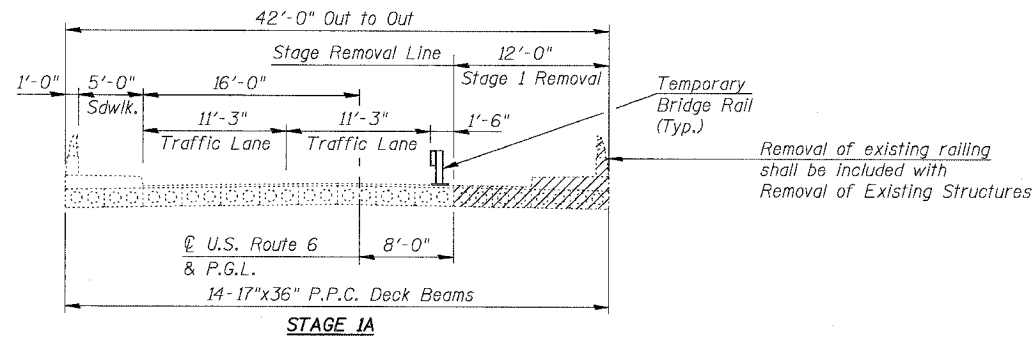

/// = Structure Removal

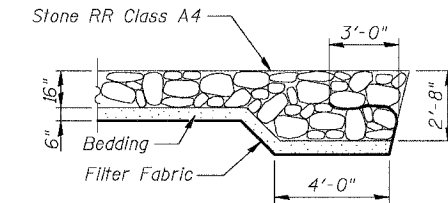

SECTION A-A

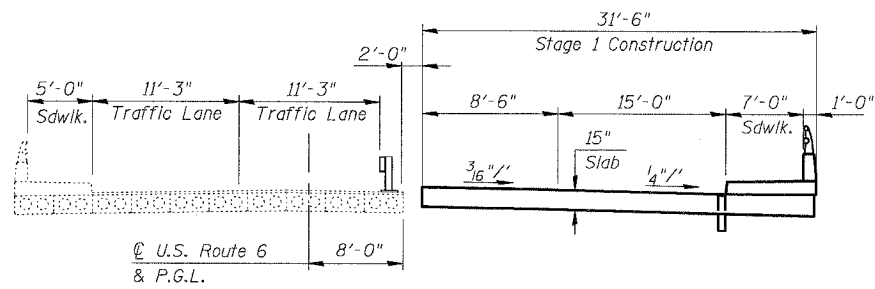

STAGE 1B
CONSTRUCTION STAGE 1

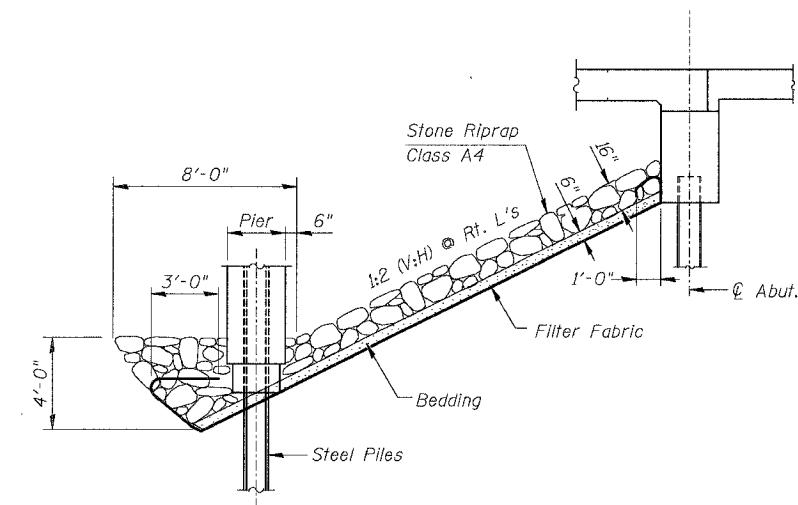

SECTION B-B

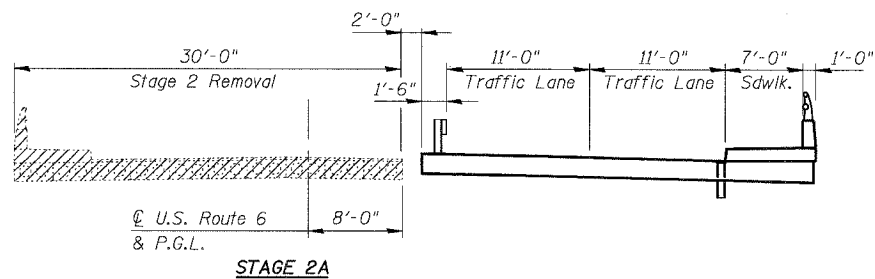

STAGE 2A

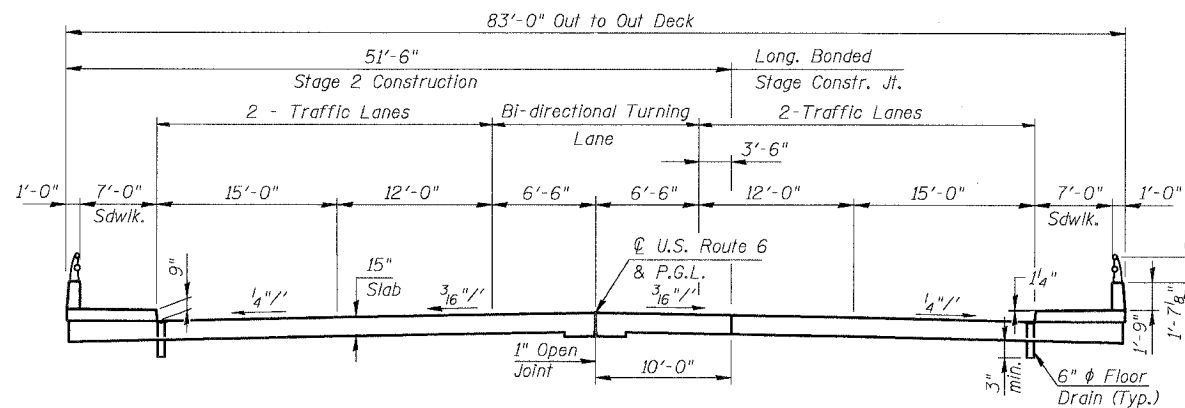

STAGE 2B (FINAL)
CONSTRUCTION STAGE 2

PROPOSED CROSS SECTIONS (LOOKING EAST)

DESIGNED	ED
CHECKED	BLU
DRAWN	EMF/LT
CHECKED	BLU

DATE: 10/25/05

CONSTRUCTION STAGING AND DETAILS
U.S. ROUTE 6 (BEDFORD ROAD)
OVER EAST FORK OF NETTLE CREEK
FAU 5952-SEC. G-BR-1

GRUNDY COUNTY
STATION 557+33.31
S.N. 032-0108

BOWMAN, BARRETT
& ASSOCIATES INC.
CONSULTING ENGINEERS
130 E. RANDOLPH STREET
CHICAGO, ILLINOIS 60601
JOB NO. 541

