

**ELEVATION**

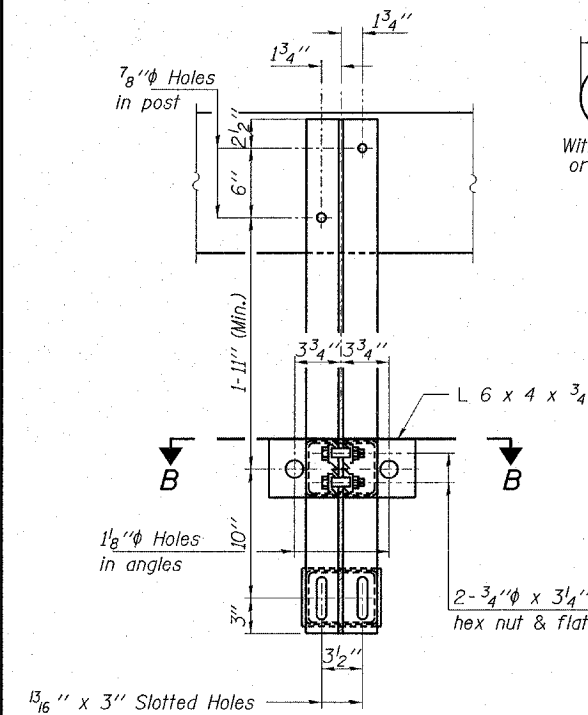

**VIEW D-D**

2-3/4"  $\phi$  x 6" Round Head Bolts (With slot or approved recess in head) with locknut & flat washer. 1/8"  $\phi$  Holes in hollow structural section may be drilled in the field.

**SECTION A-A**

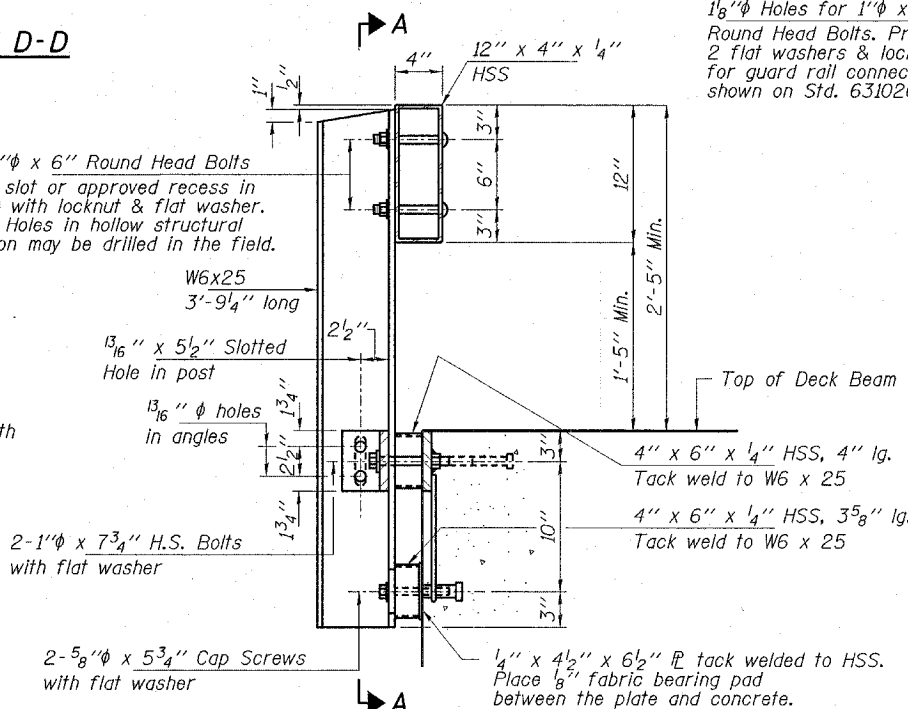

1/8"  $\phi$  Holes for 1"  $\phi$  x 4" Round Head Bolts. Provide 2 flat washers & locknuts for guard rail connection shown on Std. 631026.

\*\* Whenever the lower insert assemblies interfere with strand locations, the #3 bars shall be cut and adjusted in order to allow raising or lowering of the lower Inserts. Maximum adjustment not to exceed 2".

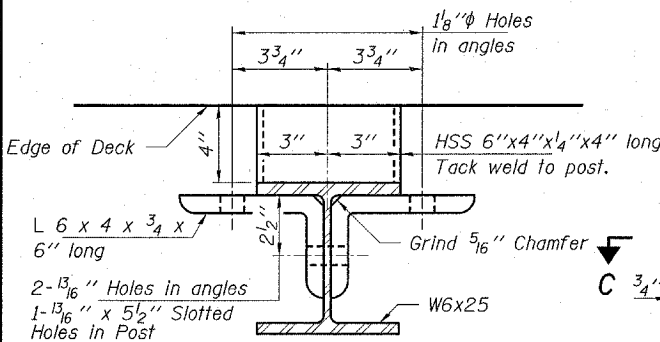

**SECTION B-B**

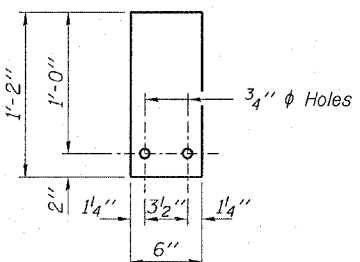

**1/4" SHIM PLATE**

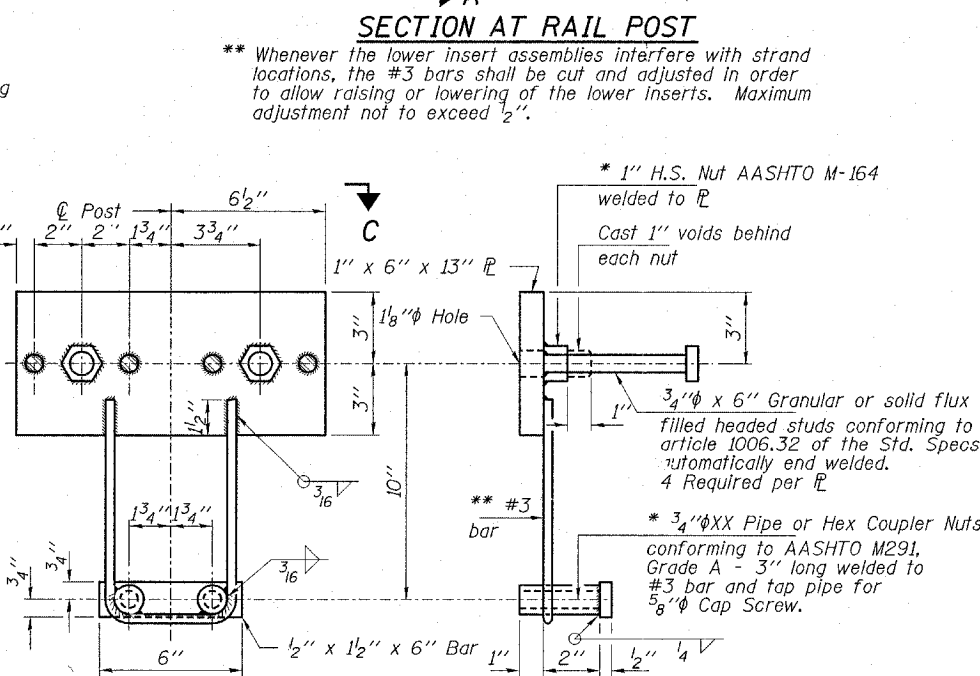

\* Threaded areas shall be plugged or blocked off during casting of beam.

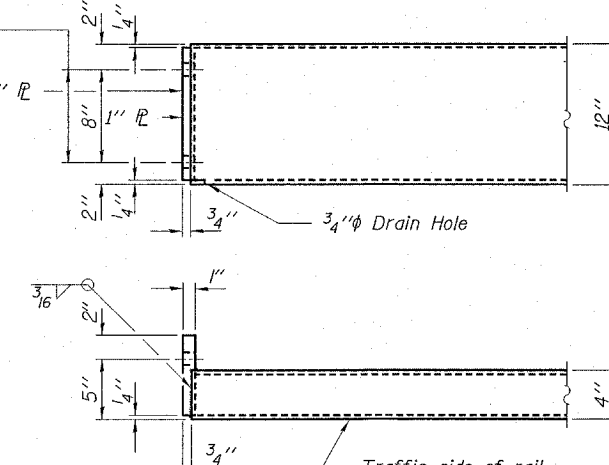

**END OF RAIL DETAILS**

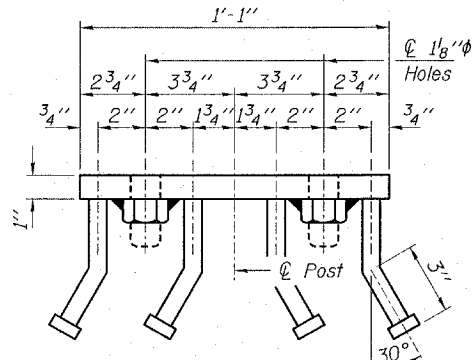

**VIEW C-C**

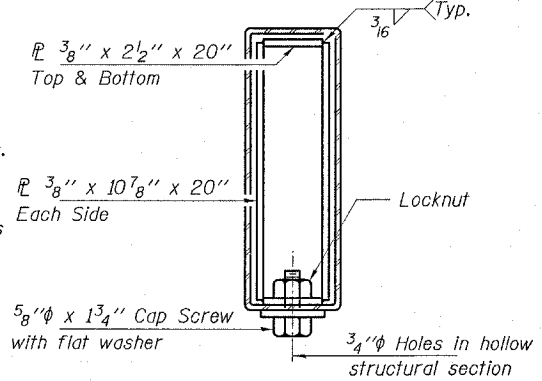

**SECTION AT RAIL SPLICE**

**NOTES**

Hollow structural sections shall conform to the requirements of A.S.T.M. designation A-500 Grade B Structural Steel Tubing and shall meet the longitudinal CVN requirements of 15 ft-lbs at 0° F.

All other steel shapes and plates shall conform to the requirements of A.A.S.H.T.O. designation M-270 Grade 36 except posts and angles shall conform to A.A.S.H.T.O. M-270 Grade 50.

Bolts, cap screws, and nuts shall conform to the requirements of A.S.T.M. designation A-307 except for high strength bolts, nuts and washers noted which shall conform to A.A.S.H.T.O. designation M-164.

All bolts, nuts, cap screws, washers and lockwashers shall be galvanized in accordance with A.A.S.H.T.O. designation M-232.

All posts, railing, rail splices, anchor devices and angles shall be galvanized after shop fabrication in accordance with A.S.T.M. A-385 and A.A.S.H.T.O. M-111. Galvanized rail shall not be painted.

Railing shall be in accordance with Section 509 of the Standard Specifications, except as noted, and shall be paid for at the contract unit price per foot for STEEL RAILING, TYPE S1.

All field drilled holes shall be coated with an approved zinc rich paint before erection.

The 3/4"  $\phi$  high strength bolts used to connect the 6 x 4 x 3/4 angles to the post shall be tightened in accordance with Art. 505.04(f)(2) of the Standard Specifications. The 1"  $\phi$  high strength bolts connecting the angles to the concrete shall be tightened to a snug fit and given an additional 1/2 turn. The 5/8"  $\phi$  cap screws in bottom of posts shall be tightened to a snug fit only.

For multi-span bridges, sufficient 1/4" x 6" x 1'-2" galvanized steel shims shall be provided to align rail between adjacent spans. Cost included with STEEL RAILING, TYPE S1.

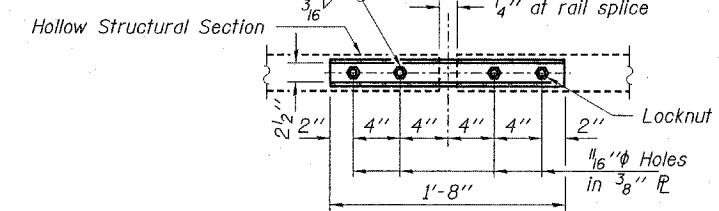

**PLAN-BOTT. SPLICE P TYPICAL**

**BILL OF MATERIAL**

Item	Unit	Quantity
Steel Railing, Type S1	Foot	159

**HLR**

Rice, Berry and Associates  
A Division of Hampton,  
Lenzini and Renwick, Inc.  
Civil & Structural Engineers  
3085 Stevenson Drive  
Suite 201  
Springfield, Illinois 62703  
217-546-3400

Account Number  
12-87-0013-1  
Date: 12/07/05  
DESIGNED: D.B. CHECKED: S.W.M. DRAWN: D.B.

**RAILING DETAILS**  
**SECTION 02-23112-00-BR**  
**TOWER HILL ROAD DISTRICT**  
**SHELBY COUNTY**  
**STR. NO. 087-3537 / STATION 10+00**