

STATE OF ILLINOIS
DEPARTMENT OF TRANSPORTATION

F.A.I. RTE.	SECTION	COUNTY	TOTAL SHEETS	SHEET NO.
72A	(84-10-1B-2)BRR	SANGAMON	5	1
		ILLINOIS	CONTRACT NO. 72121	

FOR INDEX OF SHEETS, SEE SHEET NO. 2

PROPOSED MCHD BRIDGE REPAIRS

FAI ROUTE 72A (I-72)
SECTION (84-10-1B-2)BRR
PROJECT (STATE)
BRIDGE CONCRETE REPAIR
SANGAMON COUNTY

C-96-066-23

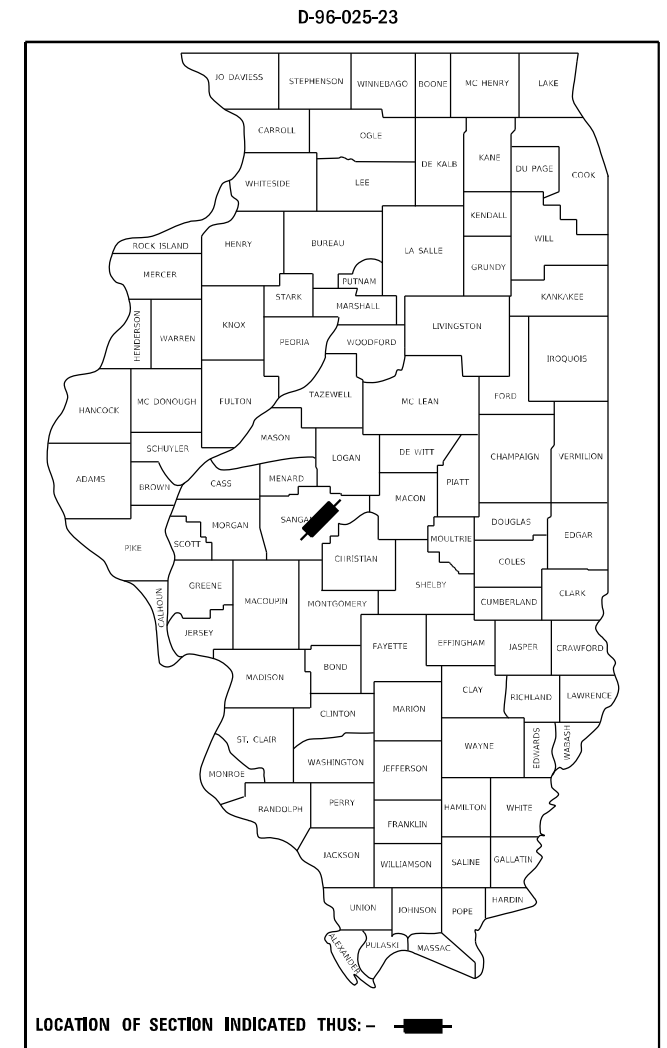

PROJECT LOCATION
SN 084-0152
I-72 WB OVER SANGAMON RIVER
3.5 MI E I-55

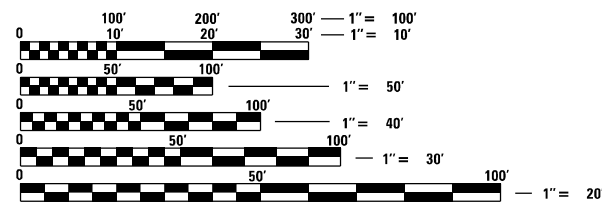
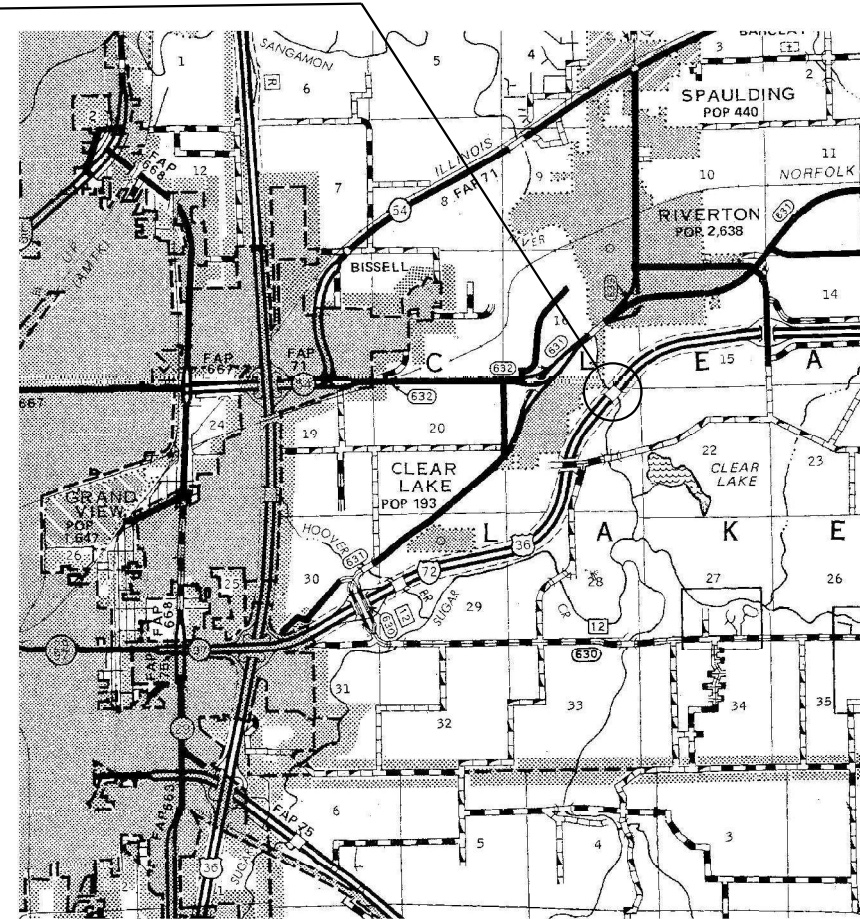

FULL SIZE PLANS HAVE BEEN PREPARED USING STANDARD ENGINEERING SCALES, REDUCED SIZED PLANS WILL NOT CONFORM TO STANDARD SCALES. IN MAKING MEASUREMENTS ON REDUCED PLANS, THE ABOVE SCALES MAY BE USED.

J.U.L.I.E.
JOINT UTILITY LOCATION INFORMATION FOR EXCAVATORS
1-800-892-0123
OR 811

BRIDGE MAINTENANCE ENGINEER: BRANDON DUDLEY - (217) 785-9290

GROSS LENGTH = 819 FT. = 0.16 MILE
NET LENGTH = 819 FT. = 0.16 MILE

CONTRACT NO. 72121

STATE OF ILLINOIS
DEPARTMENT OF TRANSPORTATION

SUBMITTED December 13, 20 22

John P. Meyer
REGIONAL ENGINEER

February 3, 2023
Scott A. Etkin
ENGINEER OF DESIGN AND ENVIRONMENT

February 3, 2023
Stephen M. Sullivan
DIRECTOR OF HIGHWAYS PROJECT IMPLEMENTATION

PRINTED BY THE AUTHORITY
OF THE STATE OF ILLINOIS

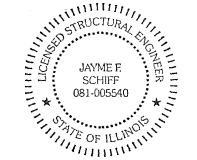
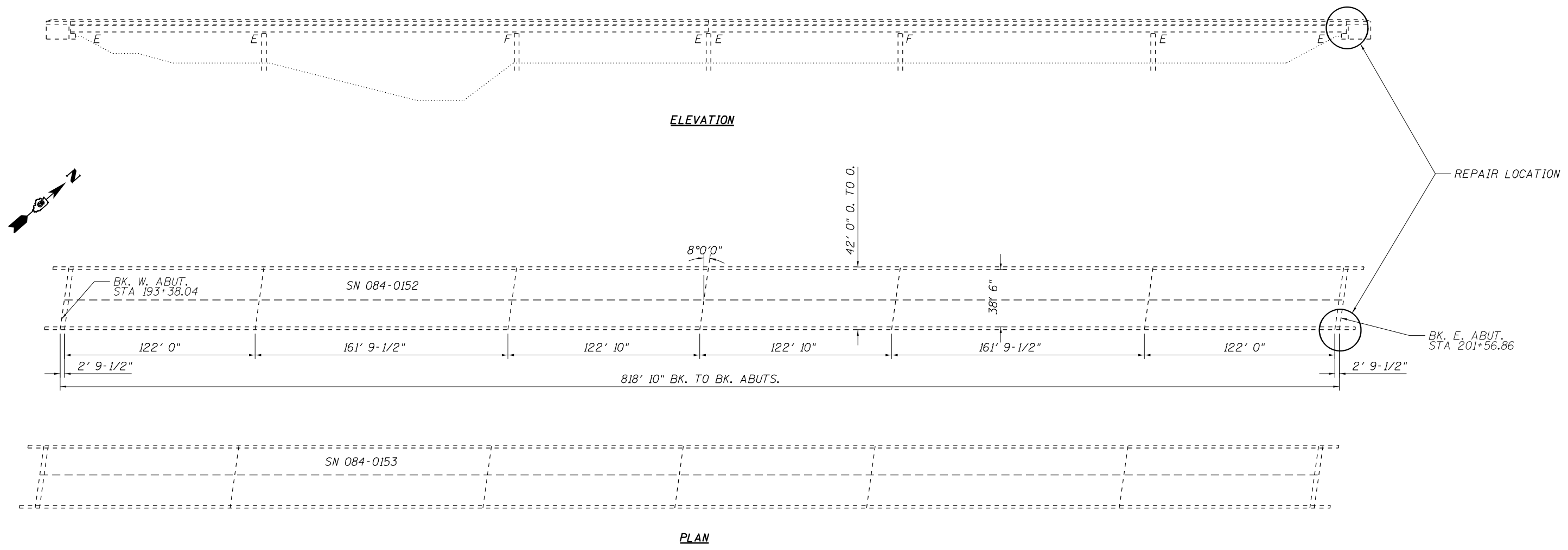

EXPIRES 11-30-2024
Jayme F. Schiff

STRUCTURE GENERAL NOTES:

PLAN DIMENSIONS AND DETAILS RELATIVE TO EXISTING PLANS ARE SUBJECT TO NOMINAL CONSTRUCTION VARIATIONS. THE CONTRACTOR SHALL FIELD VERIFY EXISTING DIMENSIONS AND DETAILS AFFECTING NEW CONSTRUCTION AND MAKE NECESSARY APPROVED ADJUSTMENTS PRIOR TO CONSTRUCTION OR ORDERING OF MATERIALS. SUCH VARIATIONS SHALL NOT BE CAUSE FOR ADDITIONAL COMPENSATION FOR A CHANGE IN THE SCOPE OF WORK, HOWEVER, THE CONTRACTOR WILL BE PAID FOR THE QUANTITY ACTUALLY FURNISHED AT THE UNIT PRICE BID FOR THE WORK.

EXISTING REINFORCEMENT BARS EXTENDING INTO THE REMOVAL AREA SHALL BE CLEANED, STRAIGHTENED, AND INCORPORATED INTO THE NEW CONSTRUCTION. ANY REINFORCEMENT BARS THAT ARE DAMAGED DURING CONCRETE REMOVAL SHALL BE REPLACED WITH AN APPROVED BAR SPLICER OR ANCHORAGE SYSTEM. COST INCLUDED WITH CONCRETE REMOVAL.

TOTAL BILL OF MATERIAL (084-0152)

ITEM	UNIT	QUANTITY
Concrete Removal	Cu. Yd.	0.9
Concrete Structures	Cu. Yd.	0.9
Protective Coat	Sq. Yd.	5

MODEL: D:\p\h\... FILE NAME: S:\Addresses\Bridges\BRR_CAD\0152..._0840152..._repair\plan-sheet.dgn

USER NAME = Brandon.Dudley	DESIGNED - BRANDON DUDLEY	REVISED -
PLOT SCALE = 100,0000' / in.	CHECKED - BRANDON DUDLEY	REVISED -
PLOT DATE = 12/13/2022	DATE - 10/26/2022	REVISED -

**STATE OF ILLINOIS
DEPARTMENT OF TRANSPORTATION**

**BRIDGE PLAN & ELEVATION
SN 084-0152**

SCALE: SHEET 1 OF 2 SHEETS STA. TO STA.

F.A.I. RTE.	SECTION	COUNTY	TOTAL SHEETS	SHEET NO.
72A	(84-10-18-2)BRR	SANGAMON	5	4
ILLINOIS FED. AID PROJECT			CONTRACT NO. 72121	

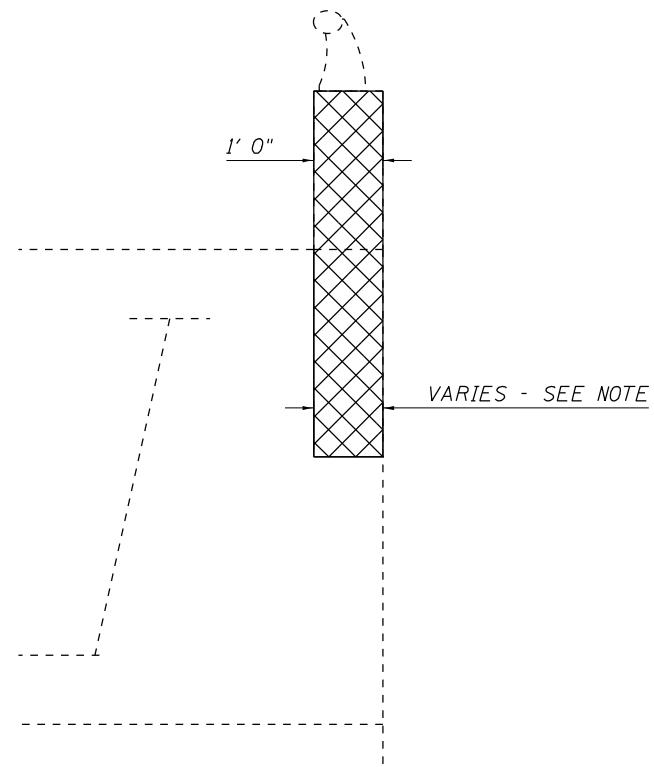

EAST ABUTMENT SECTION - LOOKING NORTHEAST

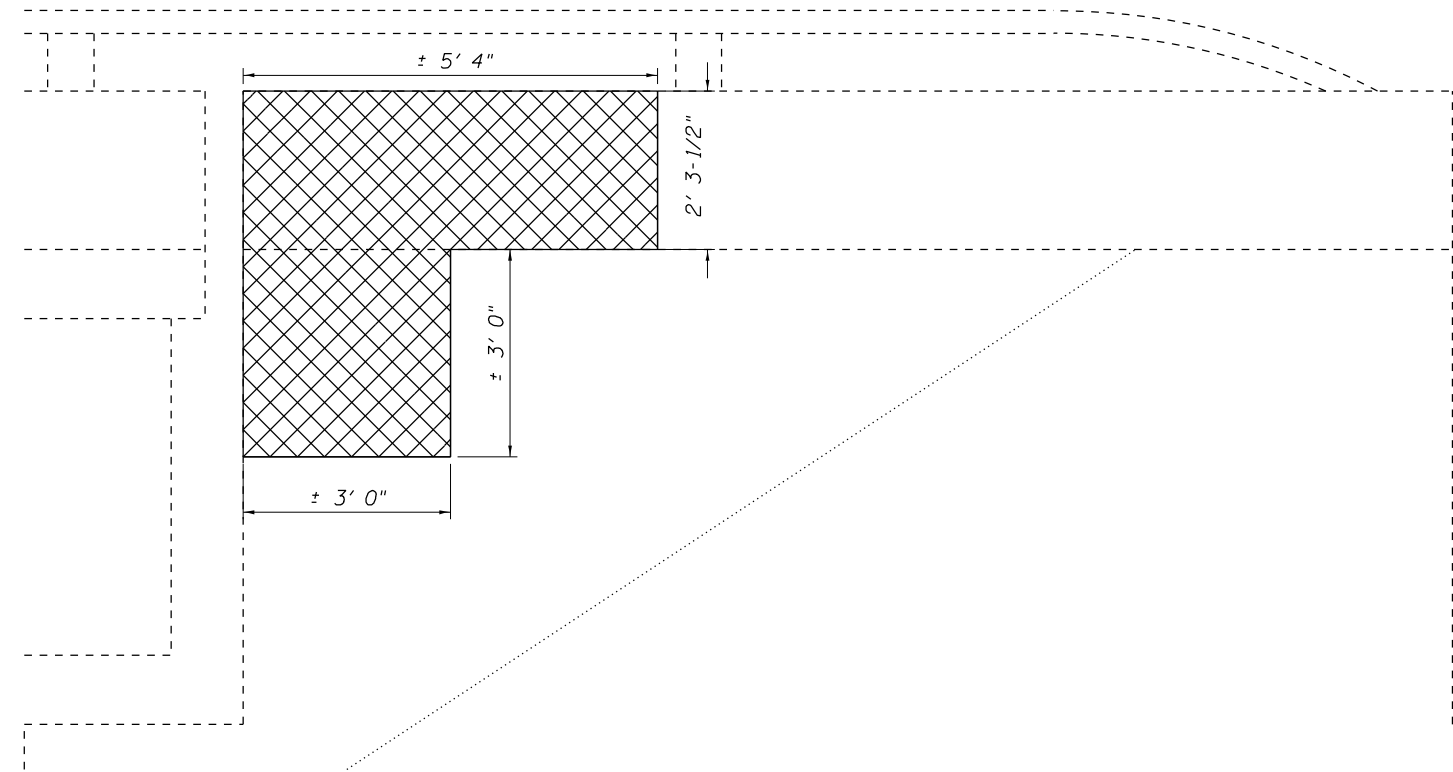

EAST ABUTMENT ELEVATION - LOOKING NORTHWEST



CONCRETE REMOVAL & CONCRETE STRUCTURES

NOTES:

- CONCRETE REMOVAL DEPTH MAY BE REDUCED IF SOUND CONCRETE IS ENCOUNTERED. THE MINIMUM REMOVAL SHALL BE 3/4" DEEPER THAN THE OUTER MAT OF REINFORCING.
- THE PROPOSED CONCRETE STRUCTURE DIMENSIONS SHALL REPLICATE THE REMOVAL DIMENSIONS.
- A 1/2" SAW CUT SHALL BE PROVIDED AROUND THE PERIMETER OF THE REMOVAL AREA.
- EXISTING REINFORCEMENT BARS EXTENDING INTO THE REMOVAL AREA SHALL BE CLEANED, STRAIGHTENED, AND INCORPORATED INTO THE NEW CONSTRUCTION. ANY REINFORCEMENT BARS THAT ARE DAMAGED DURING CONCRETE REMOVAL SHALL BE REPLACED WITH AN APPROVED BAR SPLICER OR ANCHORAGE SYSTEM. COST INCLUDED WITH CONCRETE REMOVAL.



DAMAGE PHOTOS

MODEL: Default
FILE NAME: S:\Addresses\Bridges\Barrs_CAD\72121_0840152_barope_repair\sheet.dgn

USER NAME = Brandon.Dudley	DESIGNED -	REVISED -
	DRAWN -	REVISED -
PLOT SCALE = 100,0000 ' / in.	CHECKED -	REVISED -
PLOT DATE = 12/13/2022	DATE -	REVISED -

**STATE OF ILLINOIS
DEPARTMENT OF TRANSPORTATION**

**CONCRETE REPAIR DETAIL
SN 084-0152**

SCALE: SHEET 2 OF 2 SHEETS STA. TO STA.

F.A.I. RTE.	SECTION	COUNTY	TOTAL SHEETS	SHEET NO.
72A	(84-10-18-2)BRR	SANGAMON	5	5
ILLINOIS FED. AID PROJECT			CONTRACT NO. 72121	