

RECOMMENDED LOCATION OF RAMPS

NOTE :
IF LESS THAN 48", THE MAXIMUM FLARE SLOPE SHALL BE 1:12.
IF LESS THAN 48", THE MAXIMUM FLARE SLOPE SHALL BE 1:12.

- LEGEND**
- PREFORMED JOINT FILLER
 - DUMMY JOINT
 - SLOPE BREAKPOINT
 - * FLARED CURB
 - ◇ DEPRESSED CURB

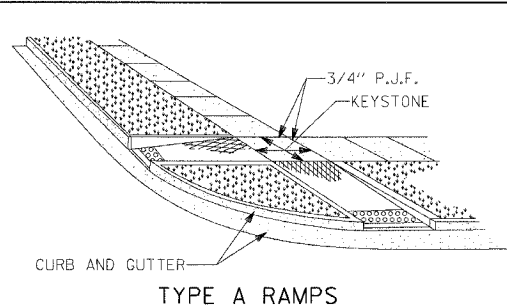

TYPE A RAMPS

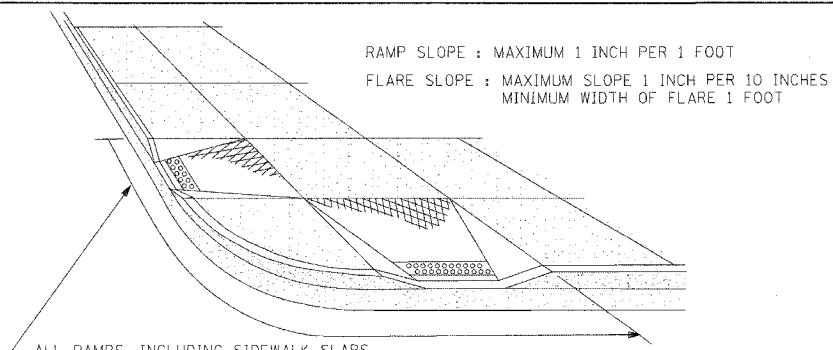

TYPE B RAMPS

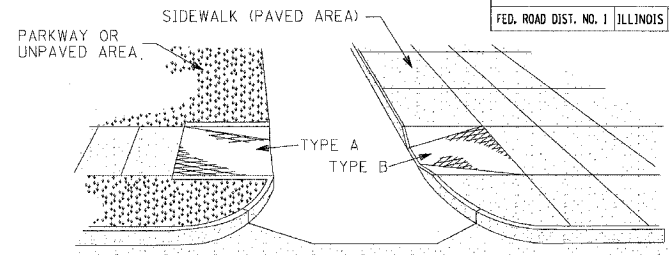

RAMPS AT ALLEY OR DRIVEWAY

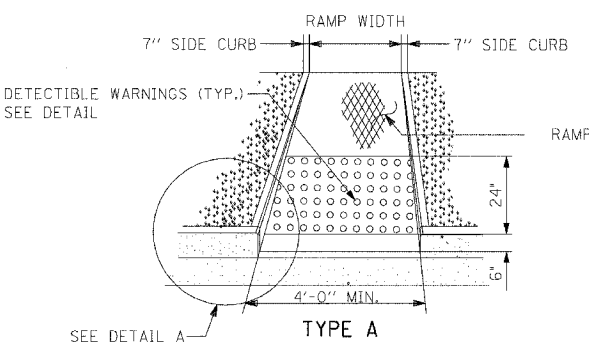

TYPE A

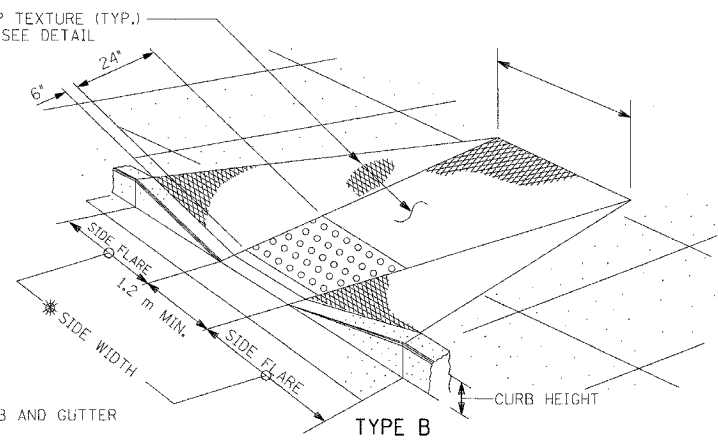

TYPE B

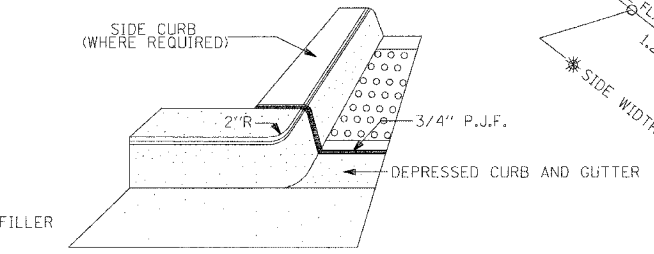

DETAIL A

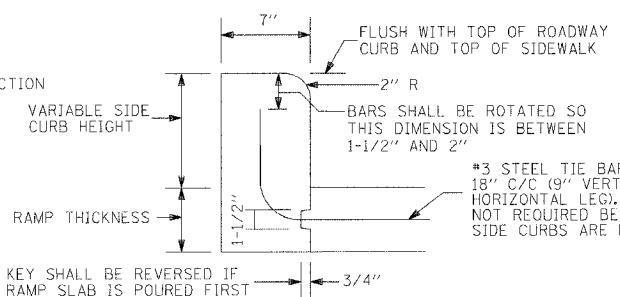

DETAIL OF SIDE CURB

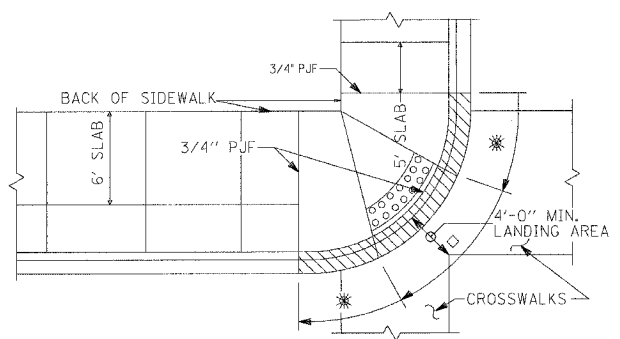

TYPICAL RAMP WITH FULL WALK 10 FEET WIDE OR LESS

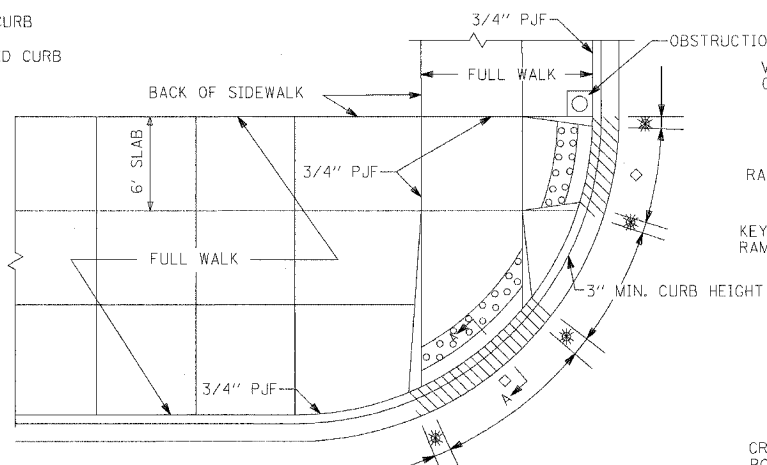

TYPICAL RAMP WITH FULL WALK GREATER THAN 10 FEET WIDE

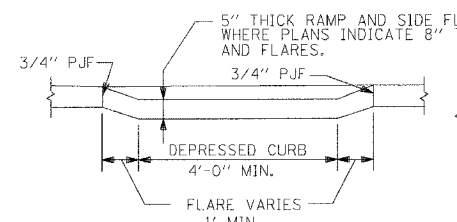

RAMP CROSS SECTION AT CURB LINE

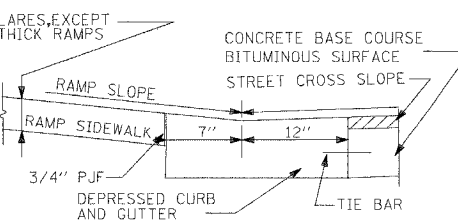

TYPICAL SECTION AT GUTTER

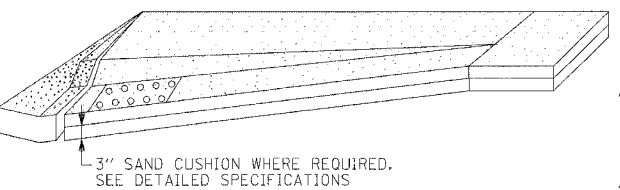

RAMP PROFILE

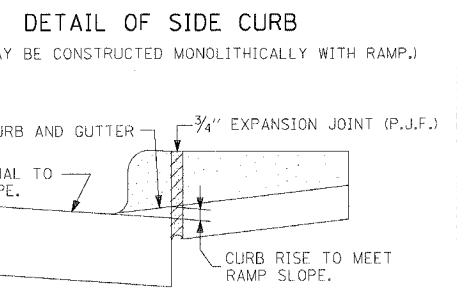

SECTION A-A

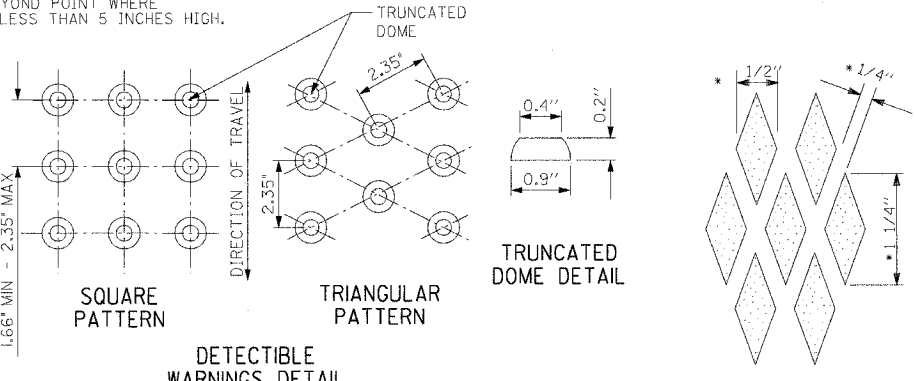

CURB HEIGHT (INCHES)	FLARE WIDTH (INCHES)
3	30
4	40
5	50
6	60
7	70
8	80
9	90

REVISIONS	
NAME	DATE

ILLINOIS DEPARTMENT OF TRANSPORTATION
F.A.I. 90/94 (DAN RYAN EXPRESSWAY)
51st ST (WENTWORTH AVE AND WELLS ST)
CITY STANDARD DETAILS
CURB RAMPS FOR PEOPLE
WITH DISABILITIES

SCALE: NONE
DATE: December 23, 2004
DRAWN BY: CDOT
CHECKED BY: JAL