

F.A.P. RTE.	SECTION	COUNTY	TOTAL SHEETS	SHEET NO.
840	(139Z-1)	KANKAKEE	24	14
STA.	TO STA.			
FED. ROAD DIST. NO.	ILLINOIS FED. AID PROJECT			

CONTRACT# 66131

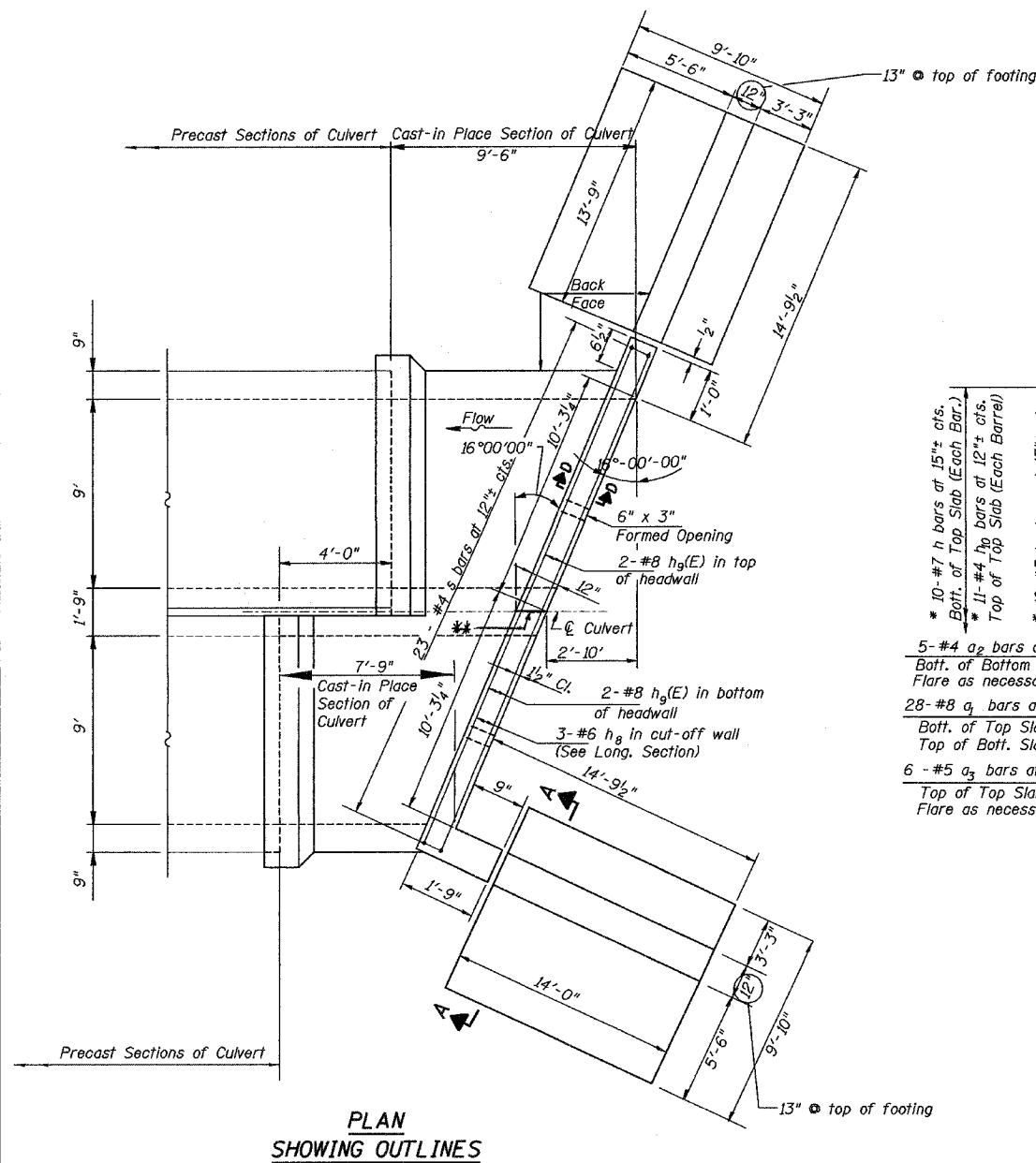

PLAN SHOWING OUTLINES

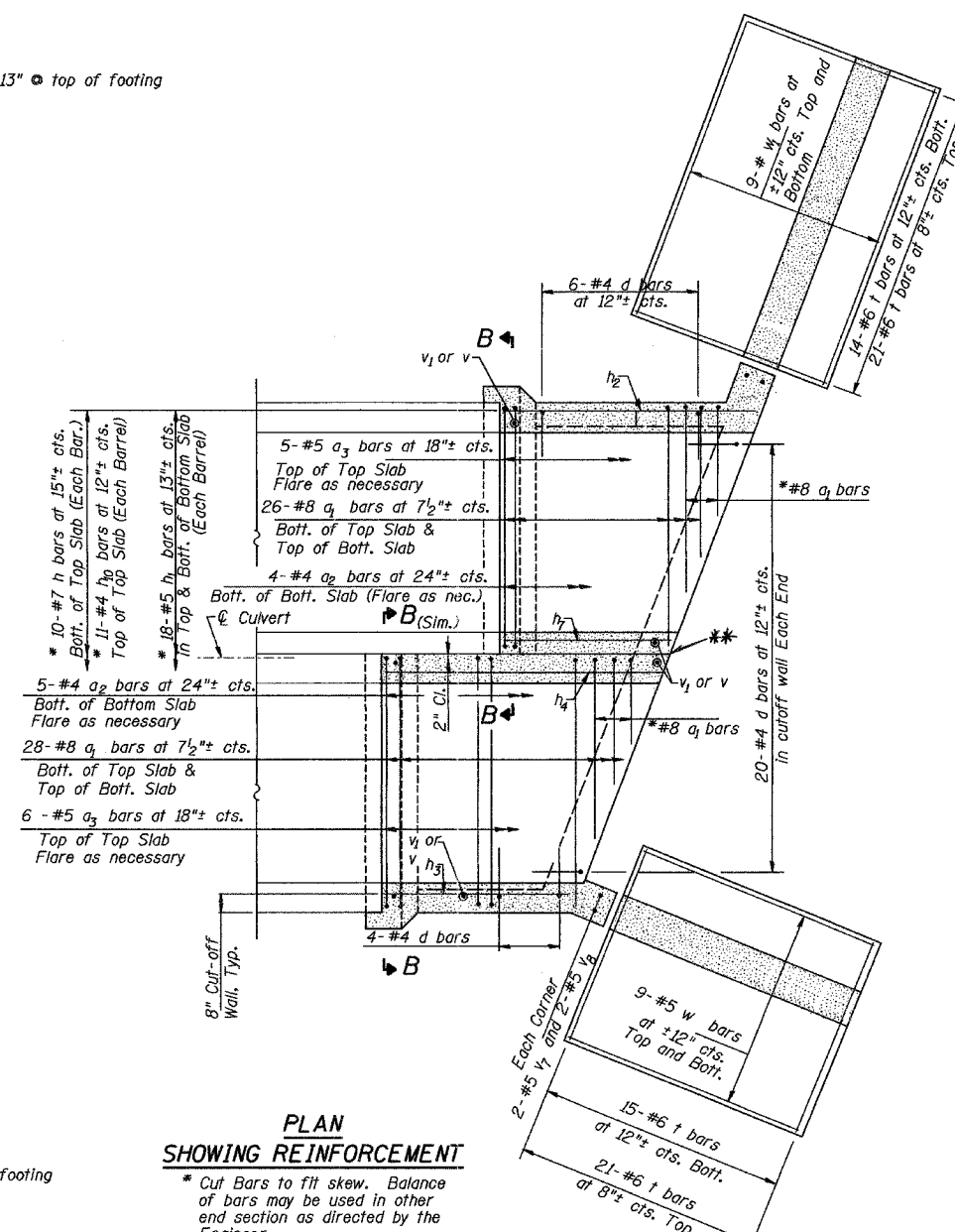

PLAN SHOWING REINFORCEMENT

* Cut Bars to fit skew. Balance of bars may be used in other end section as directed by the Engineer.

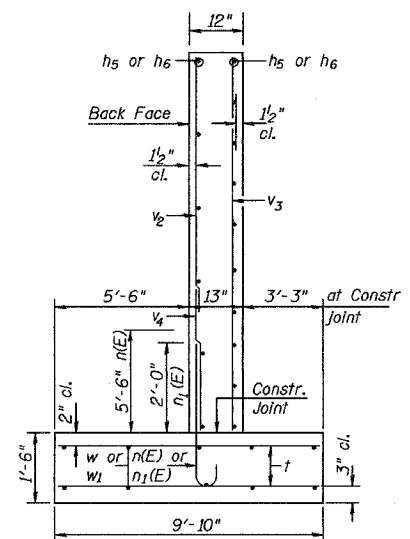

SECTION A-A

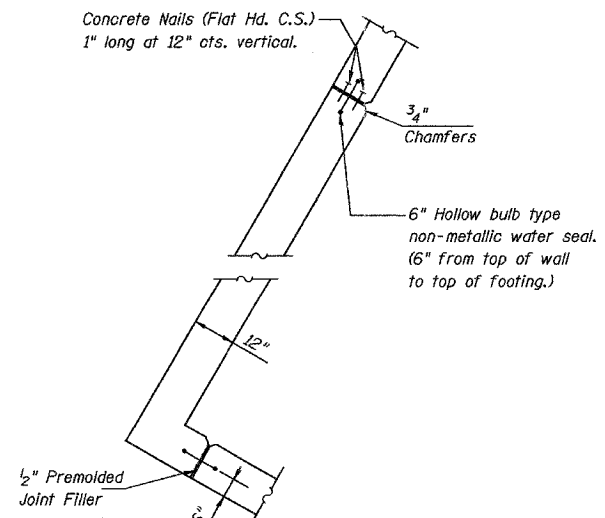

CORNER DETAIL

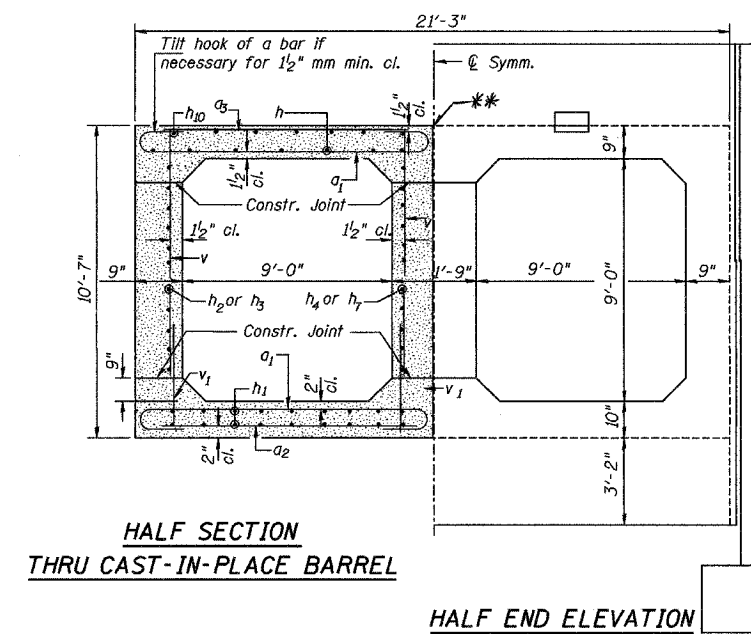

HALF SECTION THRU CAST-IN-PLACE BARREL

HALF END ELEVATION

** A 1/4" wide by 1" deep saw cut shall be made over the center of the interior wall the full length of the cast-in-place portion. One-half inch PJF shall also be placed in the headwalls at these locations.

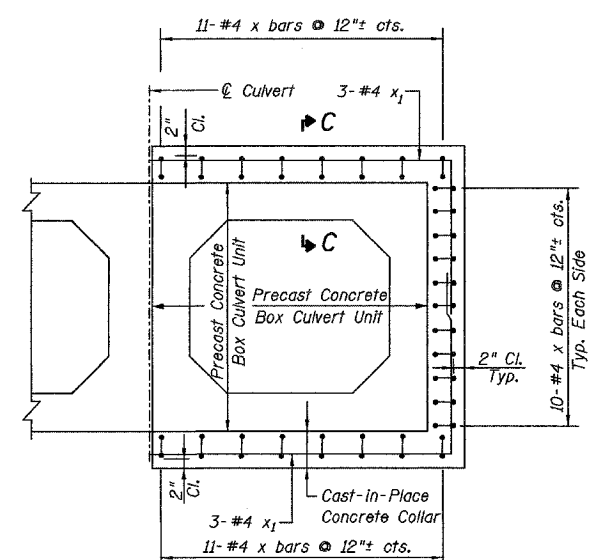

SECTION B-B

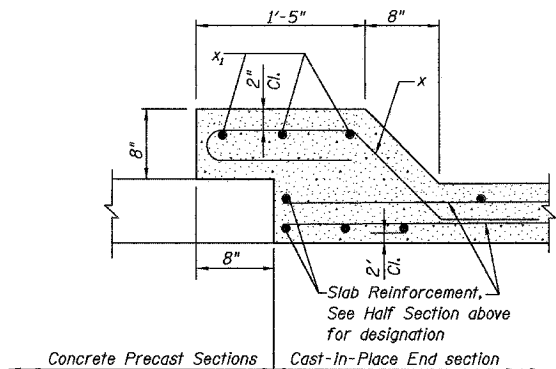

SECTION C-C

Top Slab shown, mirror horizontally for Bottom Slab Side Slab sim.

REVISIONS	
NAME	DATE
BDD	9/20/04
BDD	1/31/05

ILLINOIS DEPARTMENT OF TRANSPORTATION
BOX CULVERT END SECTION, SPECIAL, CULVERT NO. 1

SCALE: VERT. HORIZ.
 DATE
 DRAWN BY
 CHECKED BY

January 31, 2005
 ep05899/sheets.dgn