

DESIGN		
INT.	DATE	REASON

F.A.I.I. RTE.	SECTION	COUNTY	TOTAL SHEETS	SHEET NO.
6108	***	LA SALLE	679	294
STA.		TO STA.		
FED. ROAD DIST. NO.		ILLINOIS	FED. AID PROJECT	
*** (70X, 71X)RS-1, (71X-VBR)DM				
CONTRACT NO. 66225				

PLOTS & CHECKS		
INT.	DATE	REASON

FILE NAME = \$FILES
 PLOT SCALE = \$PSCALE
 PLOT DATE = \$DATE
 PLOT TIME = \$TIME
 OPERATOR = \$USER

CHECKS		
INT.	DATE	REASON

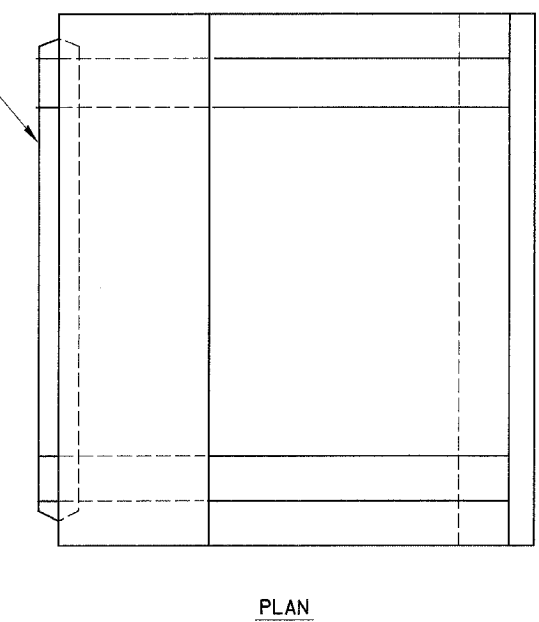
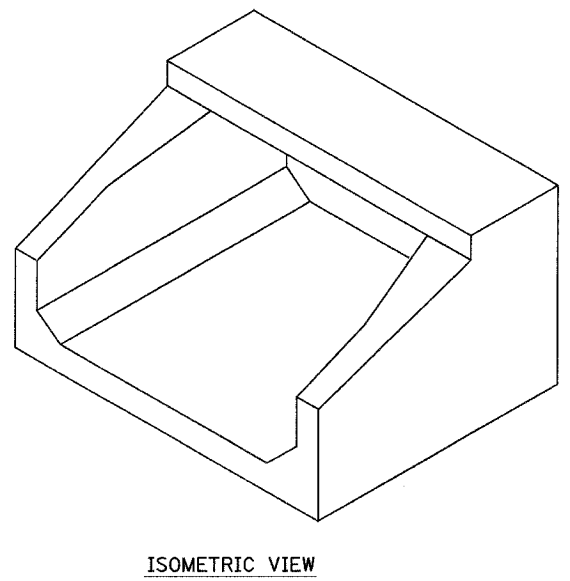
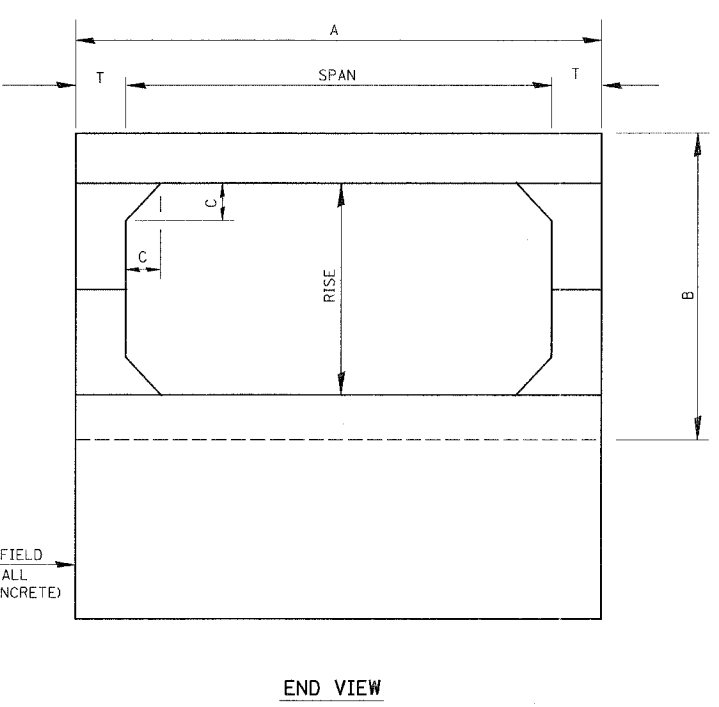
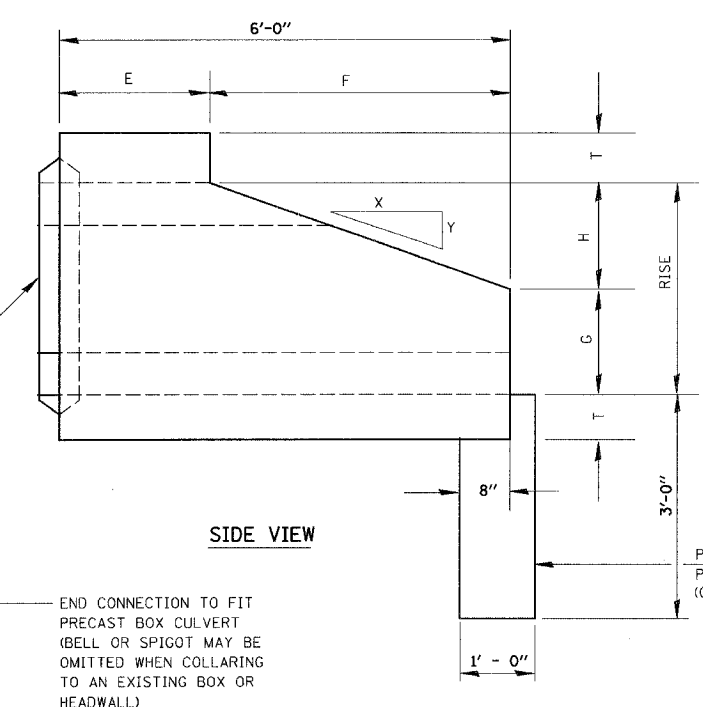

SPAN X RISE	T (INCHES)	A (FT.-IN.)	B (FT.-IN.)	C (INCHES)	E (FT.-IN.)	F (FT.-IN.)	G (FT.-IN.)	H (FT.-IN.)	SLOPE
2' X 2'	4	2 - 8	2 - 8	4	3 - 0	3 - 0	1 - 0	1 - 0	3 : 1
3' X 2'	4	3 - 8	2 - 8	4	3 - 0	3 - 0	1 - 0	1 - 0	3 : 1
3' X 3'	4	3 - 8	3 - 8	4	2 - 0	4 - 0	1 - 8	1 - 4	3 : 1
4' X 2'	5	4 - 10	2 - 10	5	3 - 0	3 - 0	1 - 0	1 - 0	3 : 1
4' X 3'	5	4 - 10	3 - 10	5	2 - 0	4 - 0	1 - 8	1 - 4	3 : 1
4' X 4'	5	4 - 10	4 - 10	5	2 - 0	4 - 0	2 - 0	2 - 0	2 : 1
5' X 2'	6	6 - 0	3 - 0	6	3 - 0	3 - 0	1 - 0	1 - 0	3 : 1
5' X 3'	6	6 - 0	4 - 0	6	2 - 0	4 - 0	1 - 8	1 - 4	3 : 1
5' X 4'	6	6 - 0	5 - 0	6	2 - 0	4 - 0	2 - 0	2 - 0	2 : 1
5' X 5'	6	6 - 0	6 - 0	6	4 - 0	4 - 0	3 - 0	2 - 0	2 : 1
6' X 2'	7	7 - 2	3 - 2	7	3 - 0	3 - 0	1 - 0	1 - 0	3 : 1
6' X 3'	7	7 - 2	4 - 2	7	2 - 0	4 - 0	1 - 8	1 - 4	3 : 1
6' X 4'	7	7 - 2	5 - 2	7	2 - 0	4 - 0	2 - 0	2 - 0	2 : 1
6' X 5'	7	7 - 2	6 - 2	7	4 - 0	3 - 0	3 - 0	2 - 0	2 : 1
7' X 3'	8	8 - 4	4 - 4	8	4 - 0	1 - 8	1 - 4	3 : 1	
7' X 4'	8	8 - 4	5 - 4	8	4 - 0	2 - 0	2 - 0	2 : 1	
7' X 5'	8	8 - 4	6 - 4	8	4 - 0	3 - 0	2 - 0	2 : 1	
8' X 3'	8	9 - 4	4 - 4	8	4 - 0	1 - 8	1 - 4	3 : 1	
8' X 4'	8	9 - 4	5 - 4	8	4 - 0	2 - 0	2 - 0	2 : 1	
8' X 5'	8	9 - 4	6 - 4	8	4 - 0	3 - 0	2 - 0	2 : 1	
9' X 3'	9	10 - 6	4 - 6	9	4 - 0	1 - 8	1 - 4	3 : 1	
9' X 4'	9	10 - 6	5 - 6	9	4 - 0	2 - 0	2 - 0	2 : 1	
9' X 5'	9	10 - 6	6 - 6	9	4 - 0	3 - 0	2 - 0	2 : 1	
10' X 4'	10	11 - 8	5 - 9	10	4 - 0	2 - 0	2 - 0	2 : 1	
10' X 5'	10	11 - 8	6 - 8	10	4 - 0	3 - 0	2 - 0	2 : 1	

540-16

ILLINOIS DEPARTMENT OF TRANSPORTATION

DETAILS

FAU 6108 (IL. RTE. 351)
SECTION (70X, 71X)RS-1, (71X-VBR)DM
LASALLE COUNTY

SCALE: VERT. _____
HORIZ. _____
DATE: 06/06/03

DRAWN BY: MABUS
DESIGNED BY: BOTT
CHECKED BY: COLBROOK

COMPUTER FILE NO.
STANDARDS-07
PROJECT: 01194_B.S
03/03/04-RPB

GREENE & BRADFORD, INC.
OF SPRINGFIELD
CONSULTING ENGINEERS
300 WEST MAIN STREET
SPRINGFIELD, ILLINOIS 62761-2700
TEL: 217-223-4400 FAX: 217-223-4401
WWW.GREENE-AND-BRADFORD.COM

REVISIONS	
NAME	DATE