

CONTRACT NO. 83560

Joint Size	"C" at 50°F	"D" at 50°F
2"	2"	1 1/2" Min.
2 1/2"	2 1/2"	1 3/4" Min.
4"	3"	2 1/2" Min.

**INSTALLATION NOTES**

- Install continuous seal in roadway.
- Install anchor blocks as indicated.

NOTE A: Maximum spacing of anchor bolts shall be 12" centers.

**SKEW LIMITATIONS**

The details of the anchor blocks and the elastomeric membrane in the parapet, as shown, are for up to 50° skews. For skews greater than 50°, the anchor blocks and the elastomeric membrane, installed according to dimension "D", might require modifications to insure a minimum clearance of 1/2" from centerline of anchor studs to edge of parapet opening. The anchor blocks and the elastomeric membrane shall also be installed to the top of the parapet with the anchor studs spaced at ±12" cts.

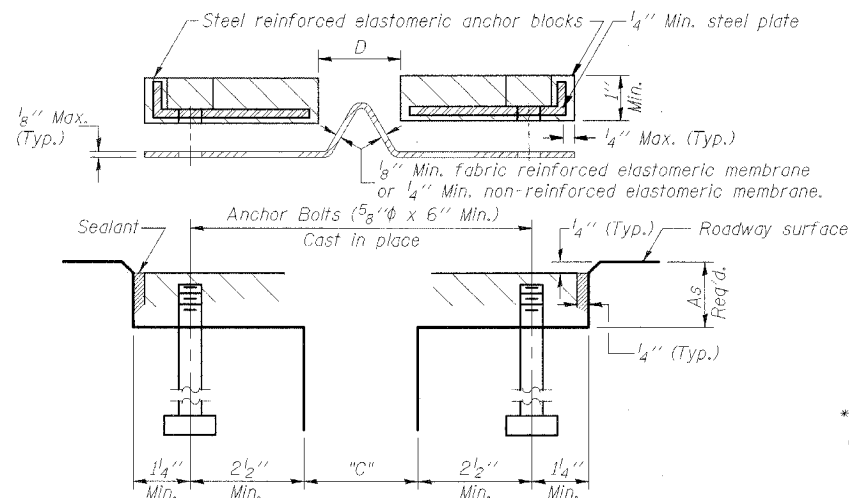

**CROSS SECTION**

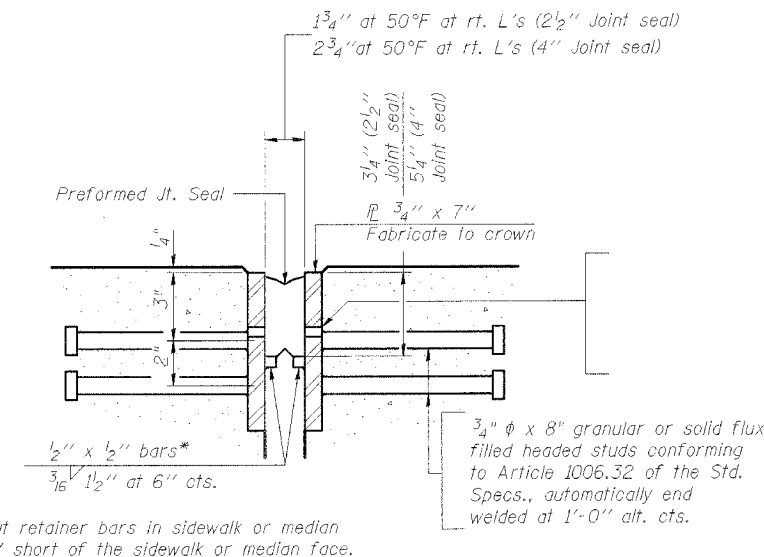

**SECTION THRU EXPANSION JOINT**  
(2 1/2" and 4" joint seals)

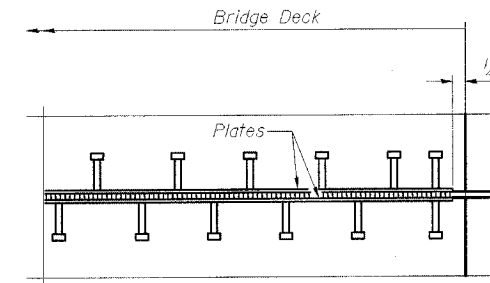

**PLAN**

Bridge Joint System (Expansion)		
Design Movement	Required Preformed Joint Seal Size	Required Strip Seal Rated movement
1"	2 1/2"	1"
1 5/8"	4"	2"

**GENERAL NOTES**

Continuous Seal Neoprene Expansion Joint shall consist of molded anchor blocks of elastomer and steel, field assembled over continuous lengths of elastomeric membrane. The elastomeric membrane shall be preformed with a single or a double upward convolution that will have a "memory" to return to its molded position upon joint closure. The convolution length shall be such that the extended length will not be greater than the manufactured length when the joint is fully expanded in its design range and will not protrude above the anchor blocks when the joint is fully compressed. Joint openings shall be adjusted according to Article 503.10(c) of the Standard Specifications when the deck is poured at an ambient temperature other than 50° F.

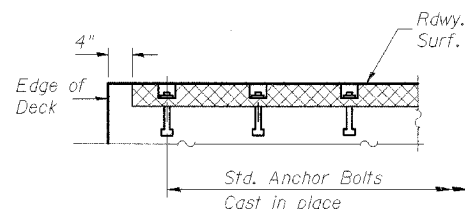

**LONG. SECTION**

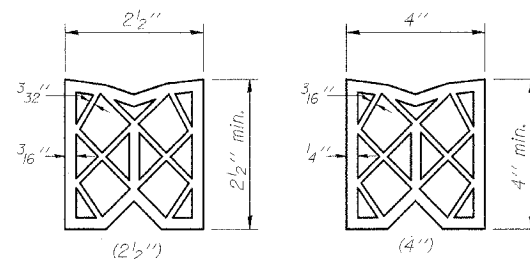

**PREFORMED JOINT SEAL**

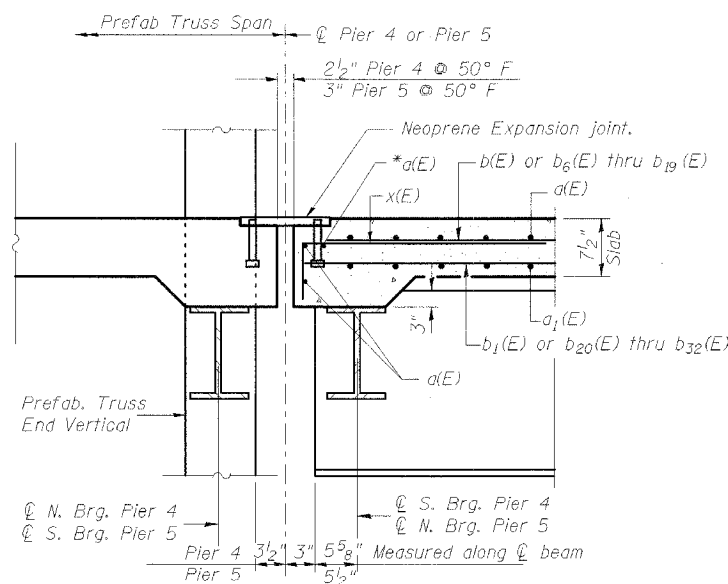

**SECTION A1-A1**  
(Pier 4 & Pier 5)

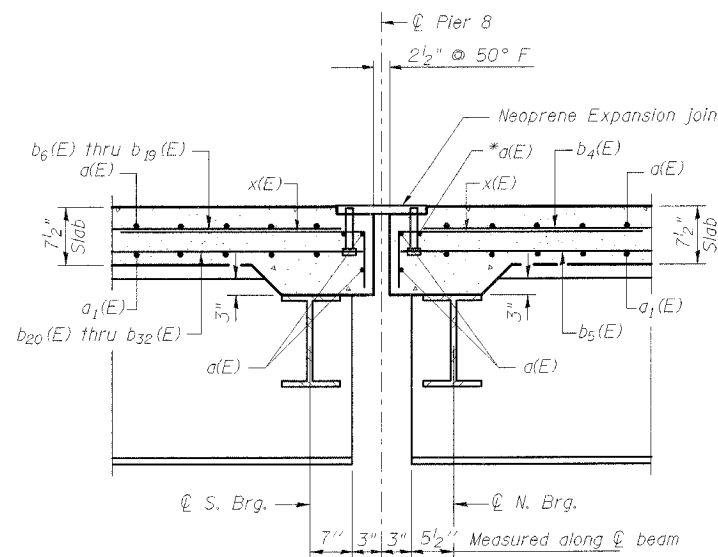

**SECTION A2-A2**  
(Pier 8)

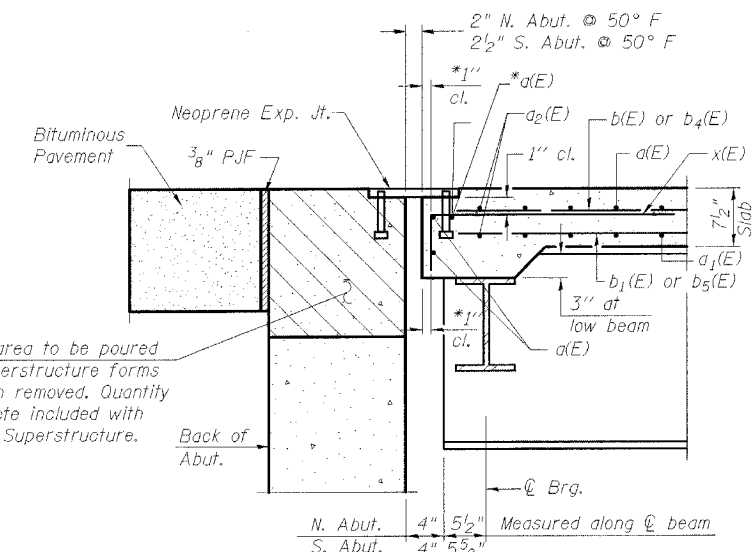

**SECTION A-A**  
(Abutments)

\* Place a(E) bars in back of anchor bolt as shown if required to maintain 1" cl. (+0-1/8"). Anchor bolts should be tied to a(E) bars.

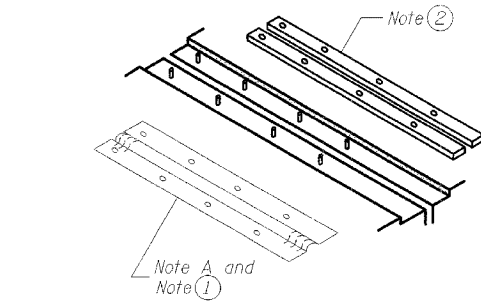

**AT ROADWAY**

PREPARED FOR:  
WHEATON PARK DISTRICT  
666 S. MAIN STREET  
WHEATON, ILLINOIS 60187



PREPARED BY:  
**CEMCON, Ltd.**  
Consulting Engineers, Land Surveyors & Planners  
2280 White Oak Circle, Suite 100  
Aurora, Illinois 60504-9675  
Ph: 630.862.2100 Fax: 630.862.2199  
E-Mail: cadd@cemcon.com Website: www.cemcon.com

REVISIONS					
NO.	DATE	DESCRIPTION	NO.	DATE	DESCRIPTION

<b>EXPANSION JOINT DETAILS - SECTIONS</b>					
<b>PEDESTRIAN/BICYCLE PATH BRIDGE OVER UNION PACIFIC RAILROAD</b>					
FILE NAME: EXPANSION	DSGN. BY: MMH	JOB NO.: 551.007	FLD. BK./PG.:	SHEET NO.	
DISC. NUMBER: 551007	DRN. BY: RDS	DATE: 04-26-04	SCALE:	23 of 54	