

teasleyck  
 teasleyck+...DATE  
 c:\projects\94941a\d00902pa.dgn  
 EAJ

FAP RTL.	SECTION	COUNTY	TOTAL SHEETS	SHEET NO.
752	(106-2Z)TS	FAYETTE		12
FED. ROAD DIST. NO. 7	ILLINOIS	FED. AID PROJECT NO.		

CONTRACT NO. 94941

BILL OF MATERIALS				
ITEM	UNIT	QUANTITY	STAGE I	STAGE II
POLYMER CONCRETE	CU FT	4.2	2.1	2.1
SILICONE JOINT SEALER, 1 1/2"	FOOT	33.0	16.5	16.5

Remove welded bar prior to placing proposed polymer concrete.  
 (Cost to be included in price per Cu. Ft. of POLYMER CONCRETE.)

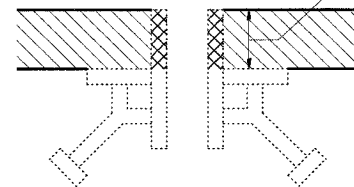

**DETAIL A**  
Existing Expansion Anchor

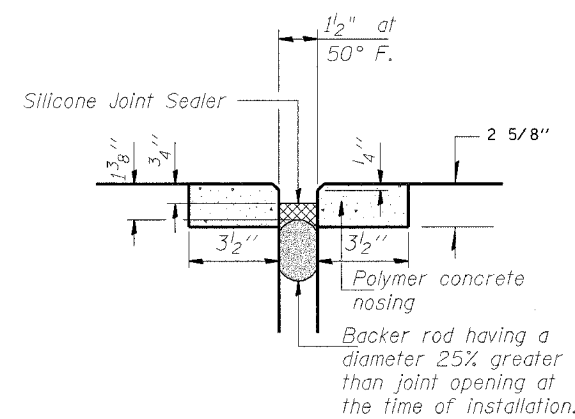

**SILICONE JOINT SEALER DETAIL**  
**DETAIL B**

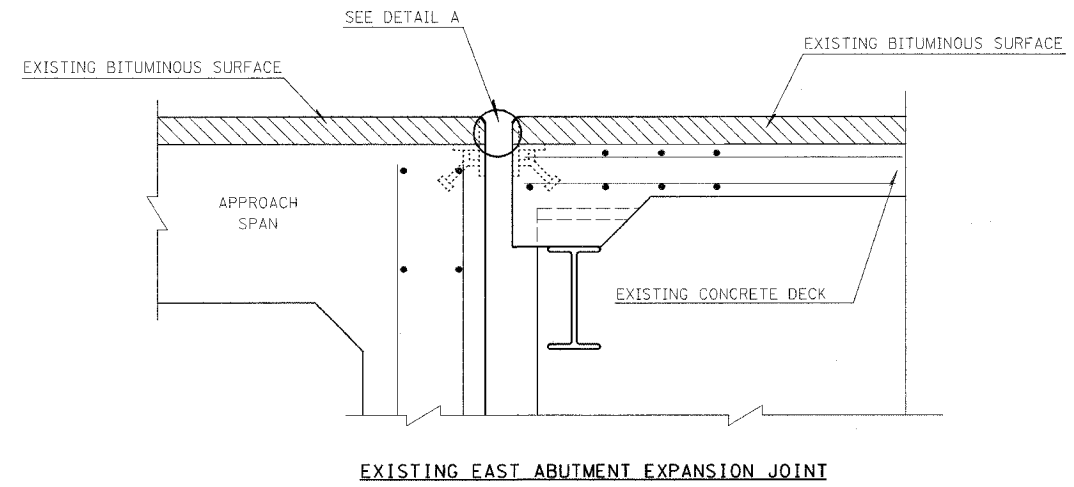

**EXISTING EAST ABUTMENT EXPANSION JOINT**

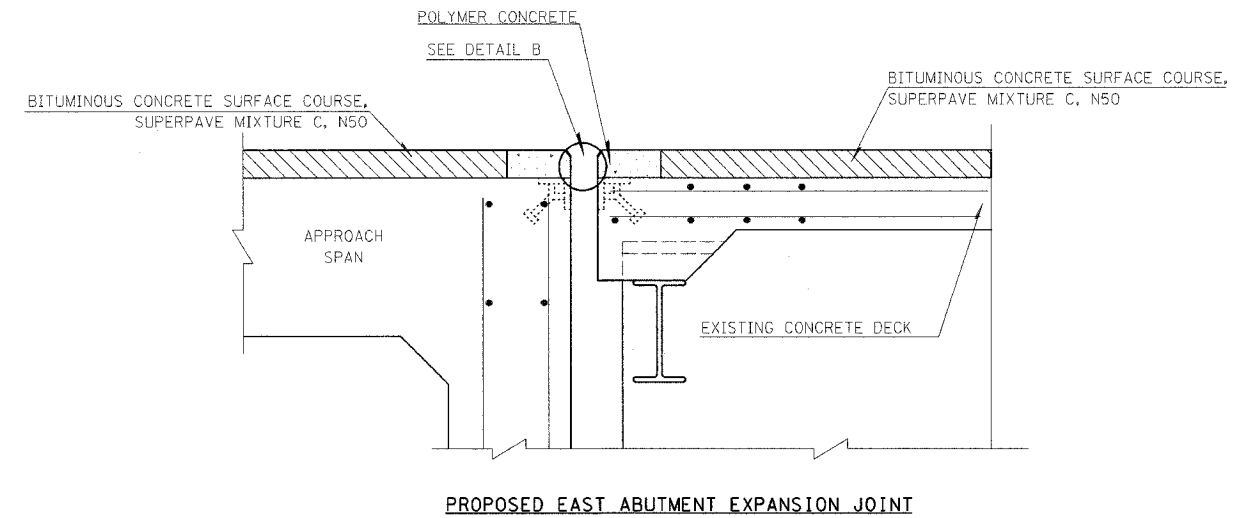

**PROPOSED EAST ABUTMENT EXPANSION JOINT**

REVISIONS	
NAME	DATE

ILLINOIS DEPARTMENT OF TRANSPORTATION

**EAST ABUTMENT  
EXPANSION JOINT**

SCALE: VERT. \_\_\_\_\_  
 HORIZ. \_\_\_\_\_

DATE \_\_\_\_\_ DRAWN BY \_\_\_\_\_  
 CHECKED BY \_\_\_\_\_