

TYPICAL SECTION D-D HAUL/PERIMETER ROAD
 NOT TO SCALE

NOTES

- CONTRACTOR SHALL CONSTRUCT BITUMINOUS BASE AND BITUMINOUS SURFACE COURSE OF HAUL ROAD AT COMPLETION OF PROJECT. ANY REGRADING AND RECOMPACTING OF THE HAUL ROAD AGGREGATE PRIOR TO PLACING BITUMINOUS PAVEMENT SHALL BE INCIDENTAL TO THE CONTRACT.

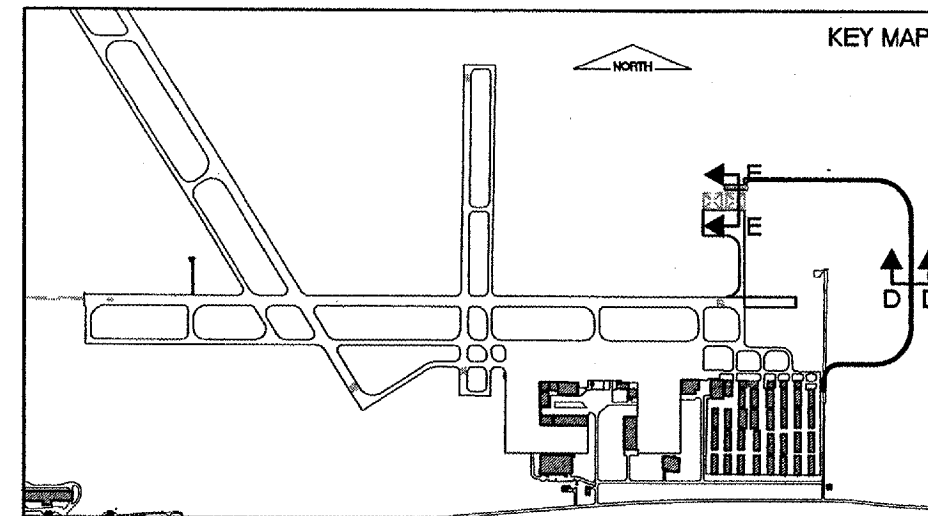

KEY MAP

REVISIONS

NUMBER	BY	DATE



THIS BAR IS EQUAL TO 2" AT FULL SCALE (34X22).

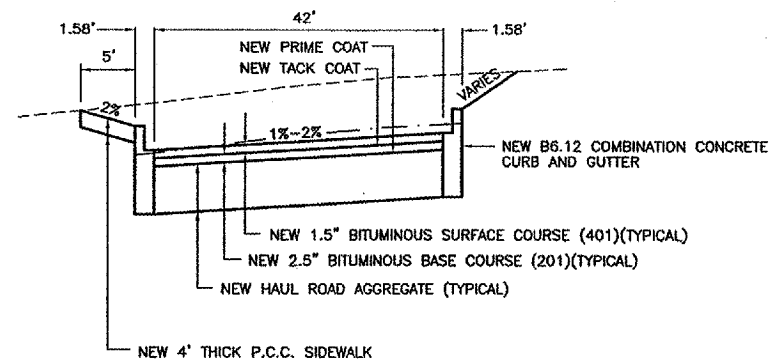

TYPICAL SECTION E-E AUTO PARKING LOT
 NOT TO SCALE

**AURORA MUNICIPAL AIRPORT
 AURORA, ILLINOIS
 CONSTRUCT NORTHEAST QUADRANT APRON,
 CONNECTING TAXIWAY AND RUNWAY 27 STOPWAY**

TYPICAL SECTIONS - SHEET 2

© Copyright CMT, Inc.
CMT
 CHAWFORD, MURPHY & TILLY, INC.
 CONSULTING ENGINEERS
 License No. 184-000619

DESIGN BY:	MJS
DRAWN BY:	JRO
CHECKED BY:	MJS
APPROVED BY:	DKP
DATE:	01/26/05
JOB No:	04285-03
ILLINOIS PROJECT: ARR-3442 A.I.P. PROJECT: 3-17-0003-B30 FINAL SUBMITTAL	
SHEET	11 OF 39 SHEETS