

TRAFFIC SIGNAL POST - MOUNTING BASE - TYPE A

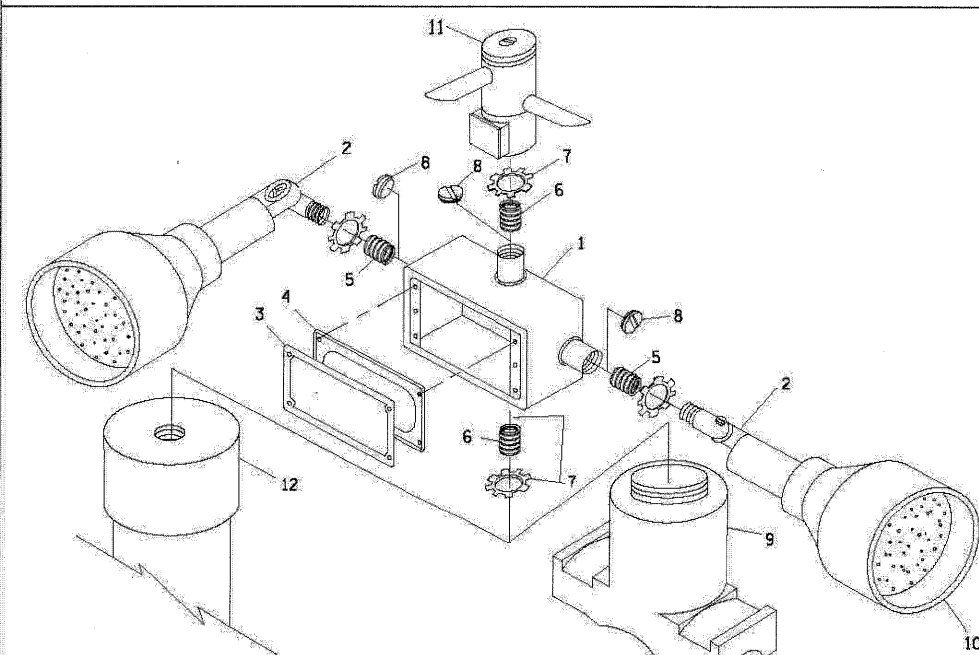

ITEM NO.	IDENTIFICATION
1	OUTLET BOX- GALV. 21 CU. IN. (0.000344 CU-M)
2	LAMP HOLDER AND COVER
3	OUTLET BOX COVER
4	RUBBER COVER GASKET
5	REDUCING BUSHING
6	3/4\" (19 mm) CLOSE NIPPLE
7	3/4\" (19 mm) LOCKNUT
8	3/4\" (19 mm) HOLE PLUG
9	SADDLE BRACKET - GALV.
10	6 WATT PAR 38 LED FLOOD LAMP
11	DETECTOR UNIT
12	POST CAP [18 FT. (5.4 m) POST MIN.]

- NOTES:**
- ALL ELECTRICAL ITEMS, EXCEPT ITEMS \*2 AND \*11 SHALL BE ALUMINUM OR GALVANIZED
  - ITEM \*1- OZ/GEDNEY FSX-1-50 OR EQUIVALENT  
ITEM \*2- MULBERRY CON-O-SHADE LAMP SHIELD OR EQUIVALENT  
ITEM \*9- "BAND-IT" SADDLE BRACKET OR EQUIVALENT
  - WHEN POST MOUNTING IS SPECIFIED, ITEM \*9 SHALL NOT BE REQUIRED. THE DETECTION UNIT SHALL BE MOUNTED DIRECTLY ON TOP OF THE CAP BY DRILLING AND TAPPING A 3/4\" (19 mm) HOLE WITH PIPE THREADS. THE POST CAP SHALL EITHER BE SCREWED TO THE TOP OF THE POST OR A MINIMUM OF 3 TIGHTENING SCREWS SHALL BE REQUIRED ON EACH CAP.

POST CAP MOUNT MAST ARM MOUNT  
EMERGENCY VEHICLE DETECTOR WITH CONFIRMATION BEACON MOUNTING DETAIL

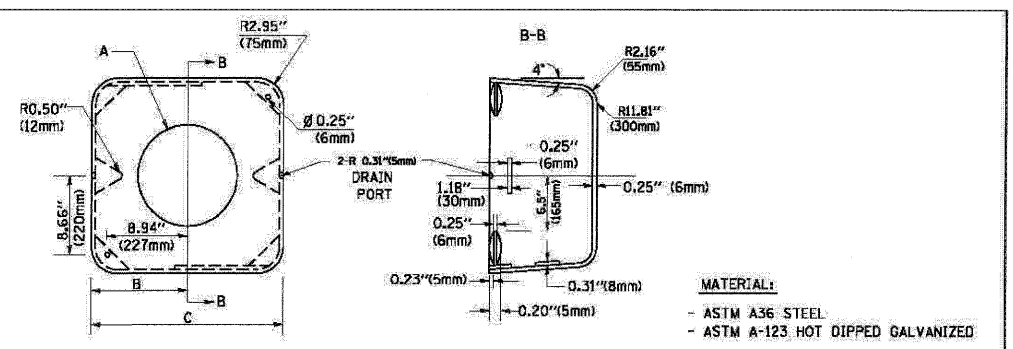

A	B	C	HEIGHT	WEIGHT
VARIABLES	9.5\" (241mm)	19\" (483mm)	7\" (178mm) - 12\" (300mm)	53 lbs (24kg)
VARIABLES	10.75\" (273mm)	21.5\" (546mm)	7\" (178mm) - 12\" (300mm)	68 lbs (31 kg)
VARIABLES	13.0\" (330mm)	26\" (660mm)	7\" (178mm) - 12\" (300mm)	81 lbs (37 kg)
VARIABLES	18.5\" (470mm)	37\" (940mm)	7\" (178mm) - 12\" (300mm)	126 lbs (57 kg)

SHROUD

- NOTES:**
- DIMENSION "A" IS EQUAL TO THE DIAMETER OF THE MAST ARM POLE AT THE TOP OF THE SHROUD, THE SHROUD SHALL BE TIGHT TO THE MAST ARM POLE.
  - THE SUPPLIER SHALL VERIFY THE ABOVE DIMENSIONS BASED ON MAST ARM REQUIREMENTS.
  - THE HEIGHT OF THE SHROUD SHALL COVER THE ANCHOR BOLTS, NUTS AND MAST ARM POLE BASE.

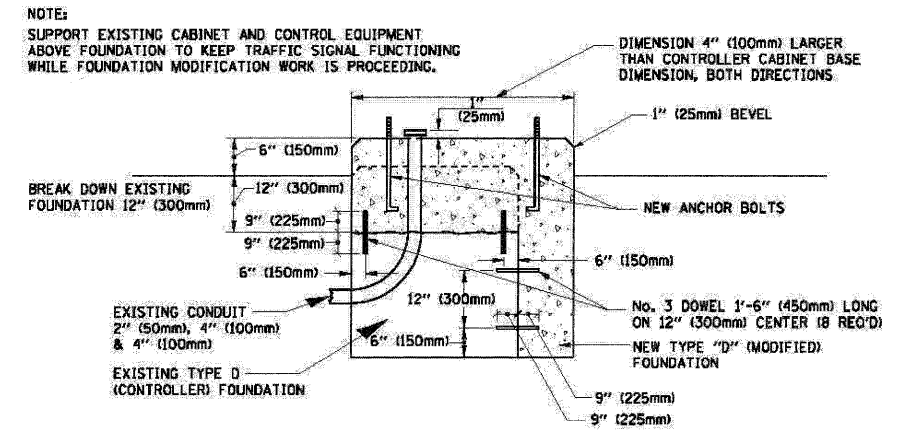

MODIFY EXISTING TYPE "D" FOUNDATION

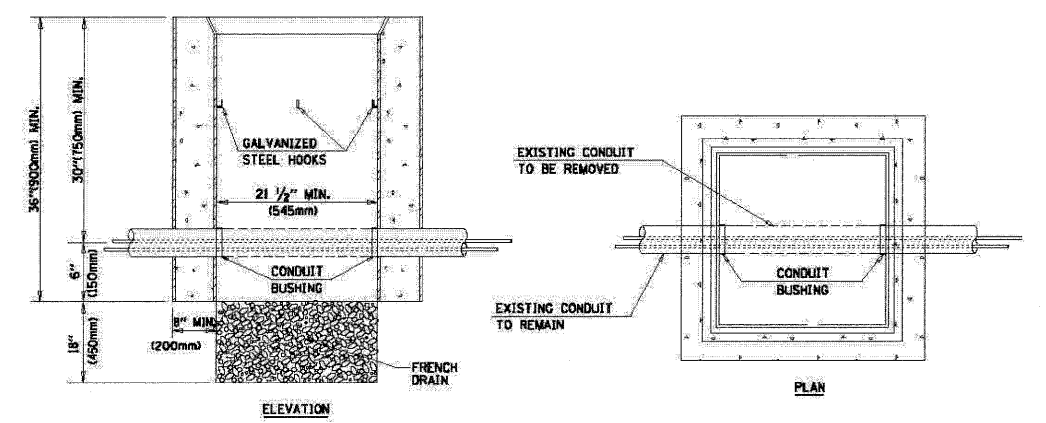

- NOTES:**
- HANDHOLE CONSTRUCTED PER STATE STANDARD 814001.
  - REMOVAL OF THE EXISTING CONDUIT FROM THE HANDHOLE AND THE INSTALLATION OF THE CONDUIT BUSHINGS SHALL BE INCIDENTAL TO THE HANDHOLE.

HANDHOLE TO INTERCEPT EXISTING CONDUIT