

END ELEVATION * See section A-A for placement

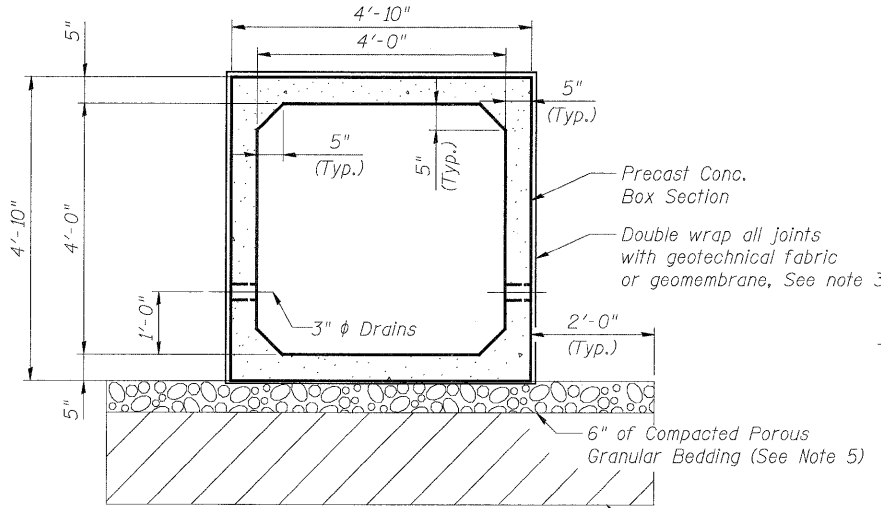

SECTION THRU PRECAST CULVERT

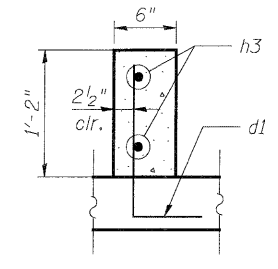

SECTION C-C

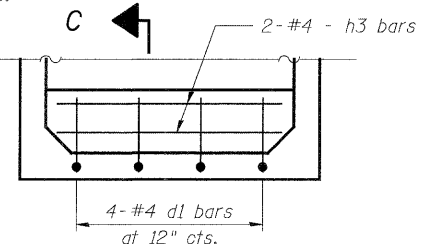

RESTRICTOR WEIR DETAIL

Cost of Restrictor Weir to be included with Precast Concrete Box Culvert 4' X 4'

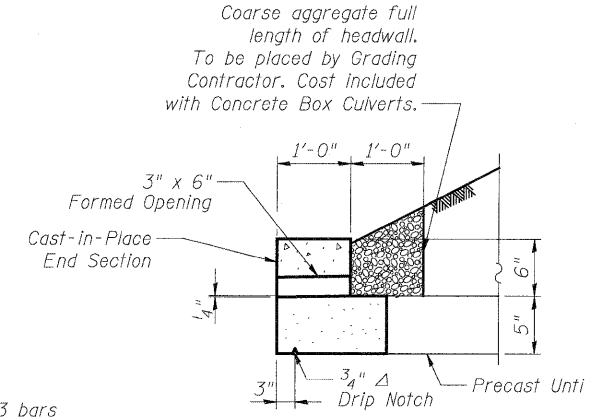

SECTION THRU HEADWALL

BILL OF MATERIAL

Bar	No.	Size	Length	Shape
d	6	#4	3' - 7"	
d1	4	#4	2' - 0"	
h	5	#4	23' - 6"	
h1	12	#4	8' - 9"	
h2	4	#6	5' - 7"	
h3	2	#4	3' - 9"	
s	7	#4	3' - 1"	□
v(E)	24	#5	5' - 7"	
v1	28	#5	4' - 8"	
w	10	#5	9' - 3"	
z	20	#6	8' - 2"	
Box Culvert End Sections			Each	1

* For information only. The cost of reinforcement is included with "Box Culvert End Sections".

NOTES:

- See Sheet S1 for Culvert Plan and Elevation.
- All Construction Joints shall be bonded.
- Geotechnical Fabric or geomembrane shall be in accordance with Section 540.06 of Standard Specifications. Cost is included with "Precast Concrete Box Culvert 4'x4'".
- The precast manufacturer shall design and detail a connection/construction joint between the precast box culvert and the C.I.P. end section. The minimum area of reinforcement passing through these construction joints shall be 0.20 sq. in./lineal ft. of welded wire fabric. The design shall be detailed in the shop drawings. The cost of connection is included in the cost of end sections.
- The porous granular bedding material shall be gradation CA-7, CA-11 or CA-18 and shall be compacted to the satisfaction of the engineer by mechanical means. Cost for porous granular bedding shall be included with "Precast Concrete Box Culverts 4' x 4'".

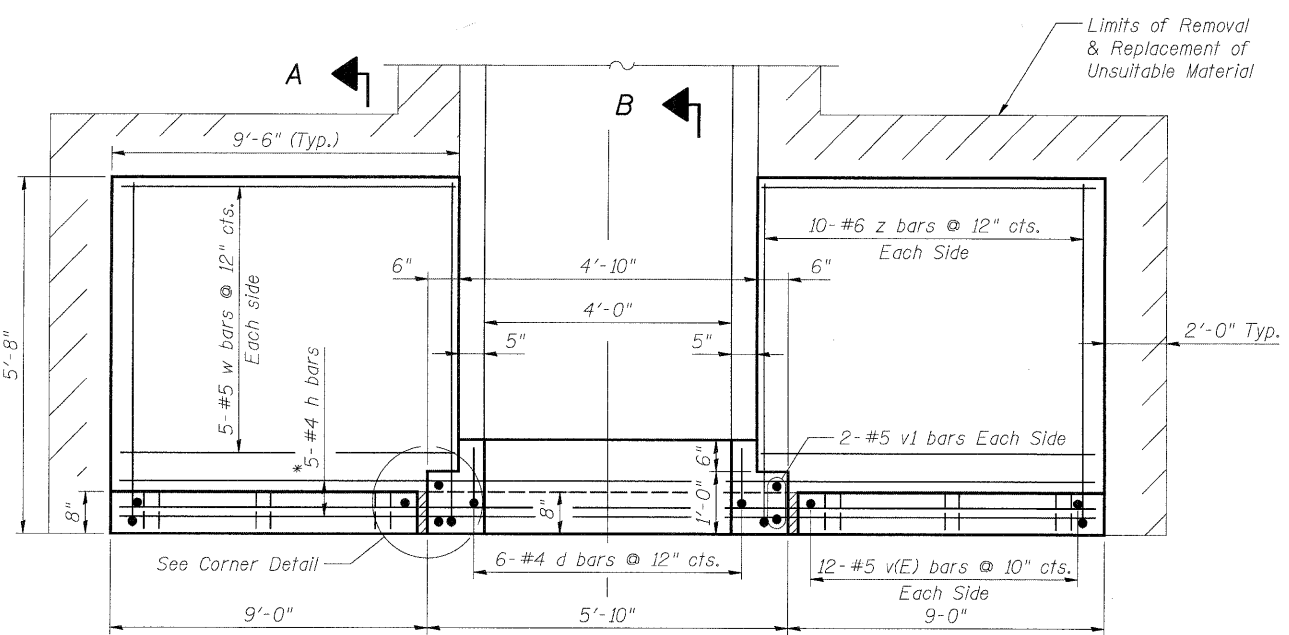

PLAN

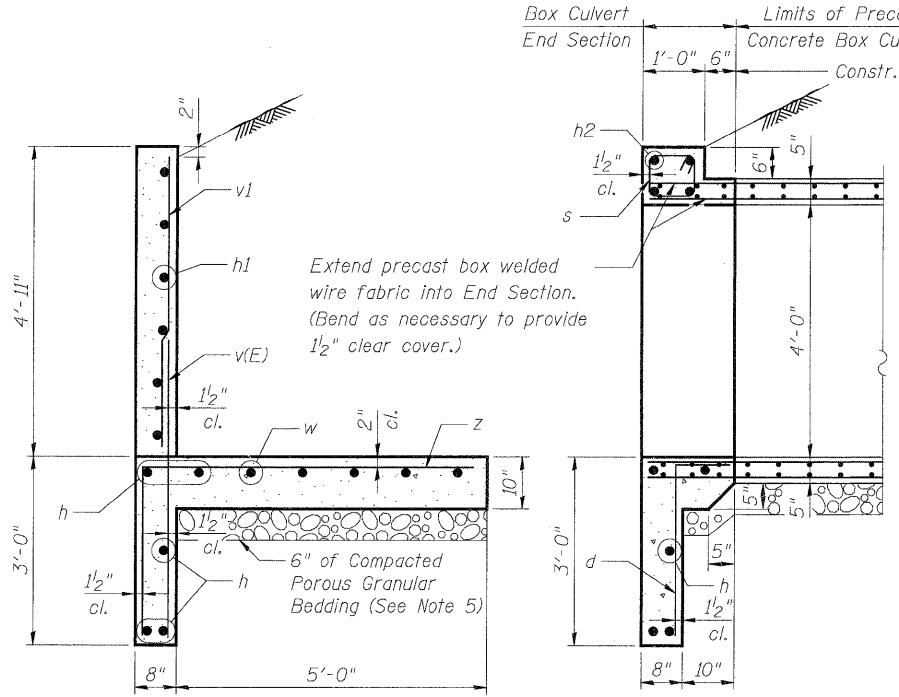

SECTION A-A

SECTION B-B

6. The limits and quantities of removal and replacement shown are based on the boring data and may be modified by the District Geotechnical and Field Engineers for variable subsurface conditions encountered in the field.

7. The Rockfill shall be capped with 6 in. of CA7 and satisfy the Standard Specifications unless otherwise indicated in the Special Provisions. The cost of the capping material shall be included in the pay item for "Rock Fill"

DESIGNED	- A. Durbak
CHECKED	- R. DiGiulio
DRAWN	- A. Durbak
CHECKED	- R. DiGiulio

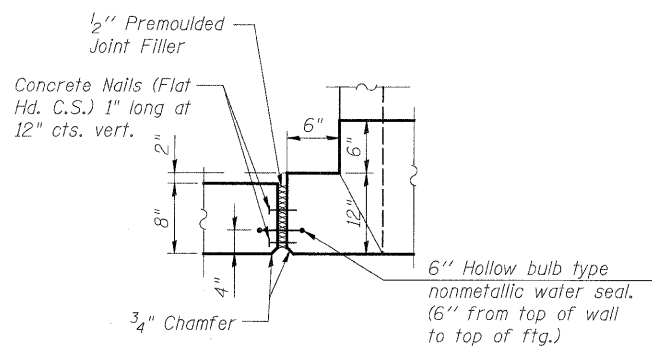
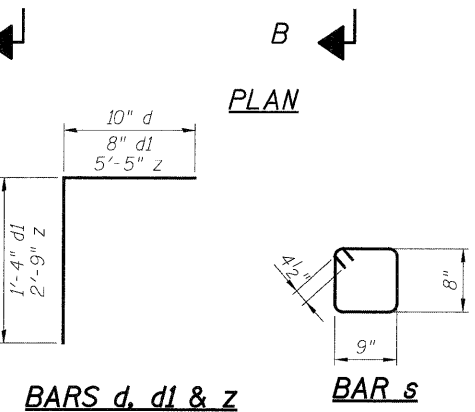

CORNER DETAIL

CULVERT DETAILS
ILLINOIS ROUTE 53
FAU 2578 SECTION 532B-1
DUPAGE COUNTY STATION 46+81.03

PATRICK ENGINEERING INC.
4970 VARSITY DRIVE
LISLE, IL 60532
patrickengineering.com

SHEET NO. S2 OF S25	F.A.P. RTE. 2578	SECTION 532B	COUNTY DUPAGE	TOTAL SHEETS 781	SHEET NO. 581
	CONTRACT NO. 60477				
12/3/2010		ILLINOIS FED. AID PROJECT			