

**METAL SHELL PILE TABLE**

| Designation and outside diameter | Wall thickness t | Weight per foot (Lbs./ft.) | Inside volume (yd. <sup>3</sup> /ft.) |
|----------------------------------|------------------|----------------------------|---------------------------------------|
| PP12                             | 0.179"           | 22.60                      | 0.0274                                |
| PP12                             | 0.250"           | 31.37                      | 0.0267                                |
| PP14                             | 0.250"           | 36.71                      | 0.0368                                |
| PP14                             | 0.312"           | 45.61                      | 0.0361                                |

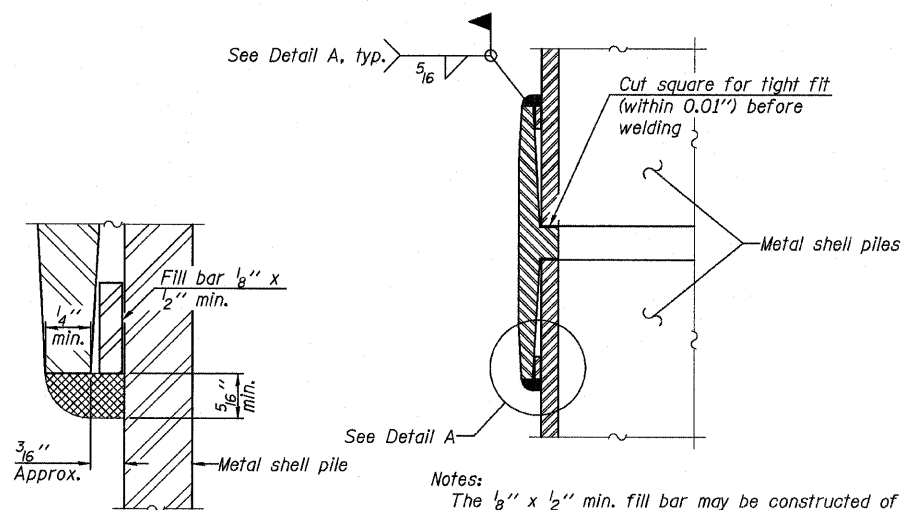

**DETAIL A**

Notes:  
 The 1/8" x 1/2" min. fill bar may be constructed of 2 bars with a 1/8" max. gap between them.  
 Pile segments shall be driven to solid contact with splicer before welding.

**WELDED COMMERCIAL SPLICE**

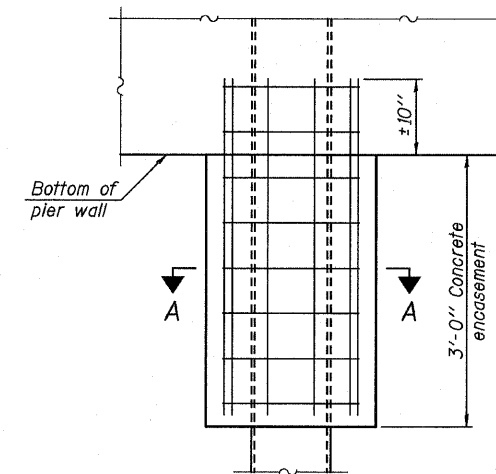

**ELEVATION**

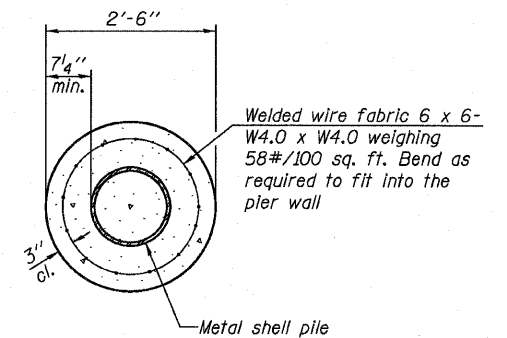

**SECTION A-A**

Note:  
 Forms for encasement may be omitted when soil conditions permit.

**CONCRETE ENCASEMENT AT PIERS**

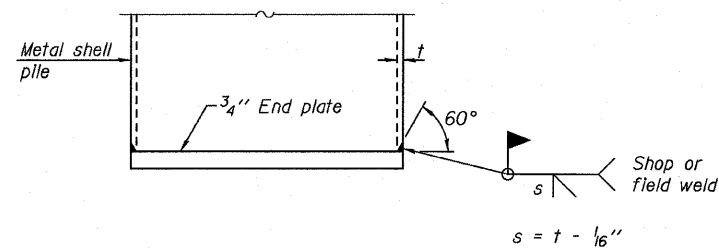

**END PLATE ATTACHMENT**

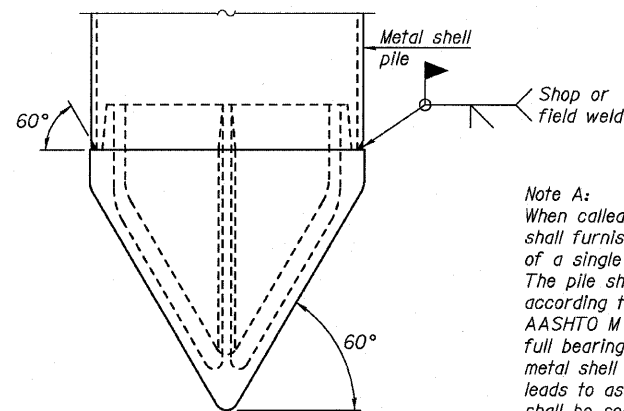

**METAL SHELL PILE SHOE ATTACHMENT**

(See Note A)

Note A:  
 When called for on the plans, the Contractor shall furnish metal shell pile shoes consisting of a single piece conical pile point as shown. The pile shoes shall be cast in one piece steel according to either ASTM A 148 Grade 90-60 or AASHTO M 103 Grade 65-35 and shall provide full bearing over the full circumference of the metal shell pile. The pile shoe shall have tapered leads to assure proper alignment and fitting and shall be secured to the pile with a circumferential weld.

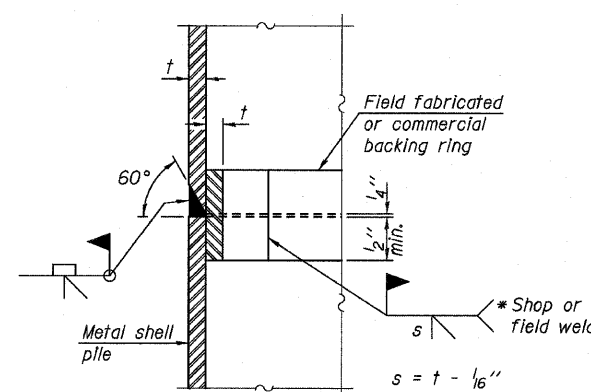

**COMPLETE PENETRATION WELD SPLICE**

\* Field fabricated backing ring may be made from pile shell by removing segment to allow reducing circumference and vertically rejoin with partial joint penetration weld.

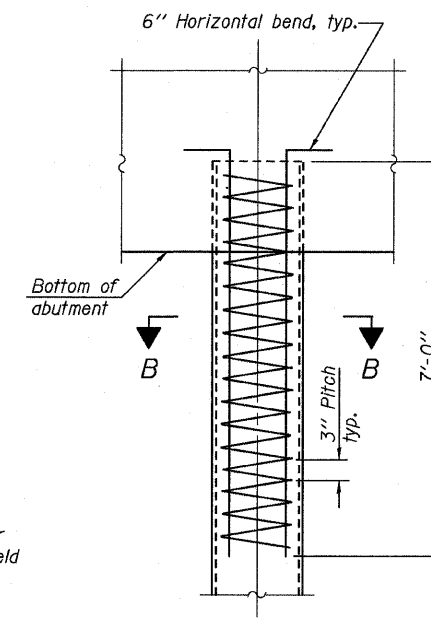

**ELEVATION**

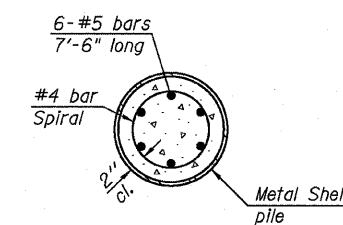

**SECTION B-B**

**METAL SHELL REINFORCEMENT AT ABUTMENTS**

Note:  
 The metal shell piles shall be according to ASTM A 252 Grade 3.

F-MS

7-1-10



|              |                  |           |
|--------------|------------------|-----------|
| USER NAME =  | DESIGNED - JXH   | REVISED - |
| PLOT SCALE = | CHECKED - JW     | REVISED - |
| PLOT DATE =  | DRAWN - JLS      | REVISED - |
|              | CHECKED - JXH/JW | REVISED - |

STATE OF ILLINOIS  
 DEPARTMENT OF TRANSPORTATION

METAL SHELL PILE DETAILS  
 STRUCTURE NUMBER 049-0238 STATION 1159 + 35.95

SHEET NO. 5-10 OF 5-15 SHEETS

|                  |               |  |                 |              |
|------------------|---------------|--|-----------------|--------------|
| F.A.U. RTE. 1238 | SECTION C-B-I | COUNTY LAKE                                  | TOTAL SHEETS 61 | SHEET NO. 38 |
| DATE: 01-10-2011 |               | ILLINOIS FED. AID PROJECT CONTRACT NO. 60J67 |                 |              |