

**STAGE I CONSTRUCTION & TRAFFIC**  
(Looking West)

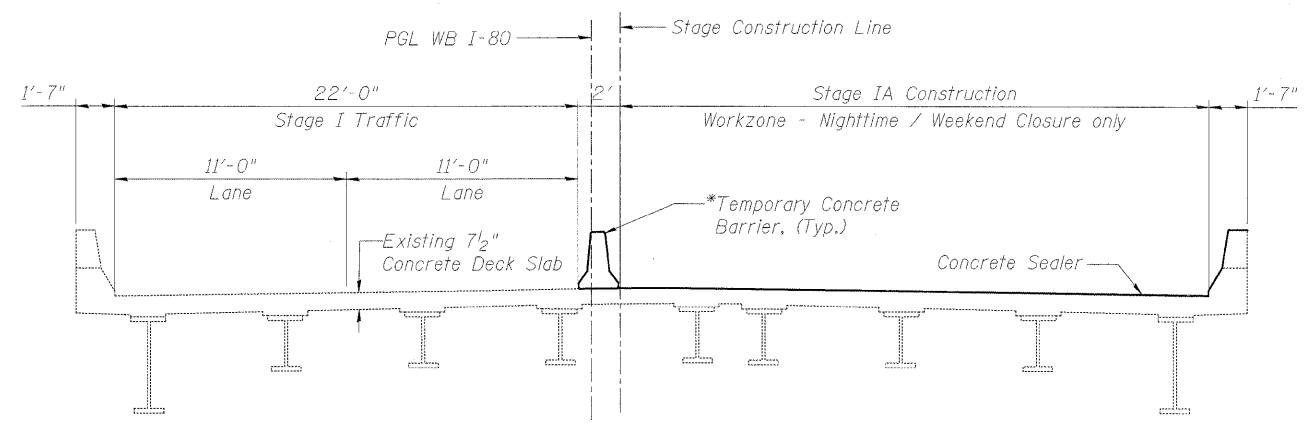

**STAGE IA CONSTRUCTION & TRAFFIC**  
(Looking West)

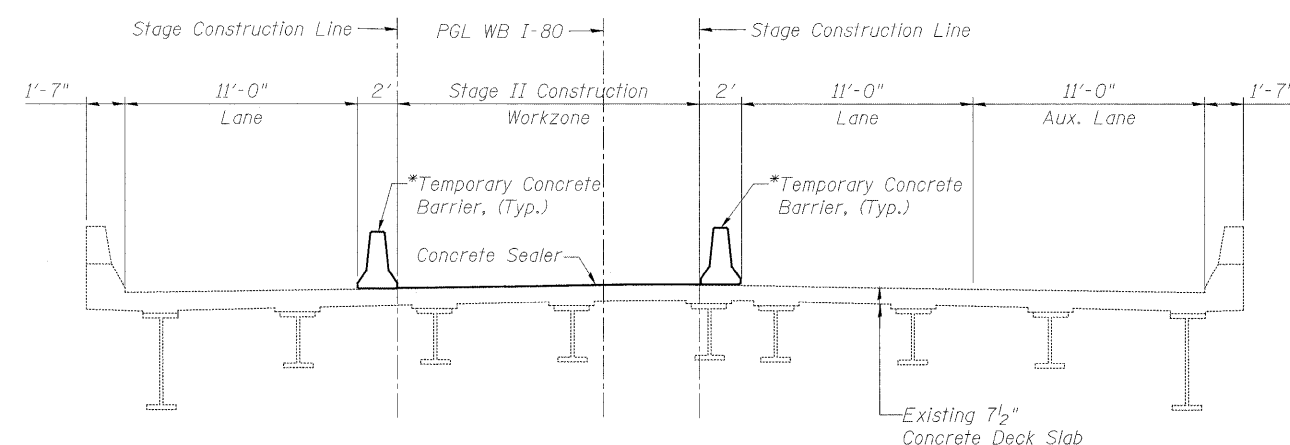

**STAGE II CONSTRUCTION & TRAFFIC**  
(Looking West)

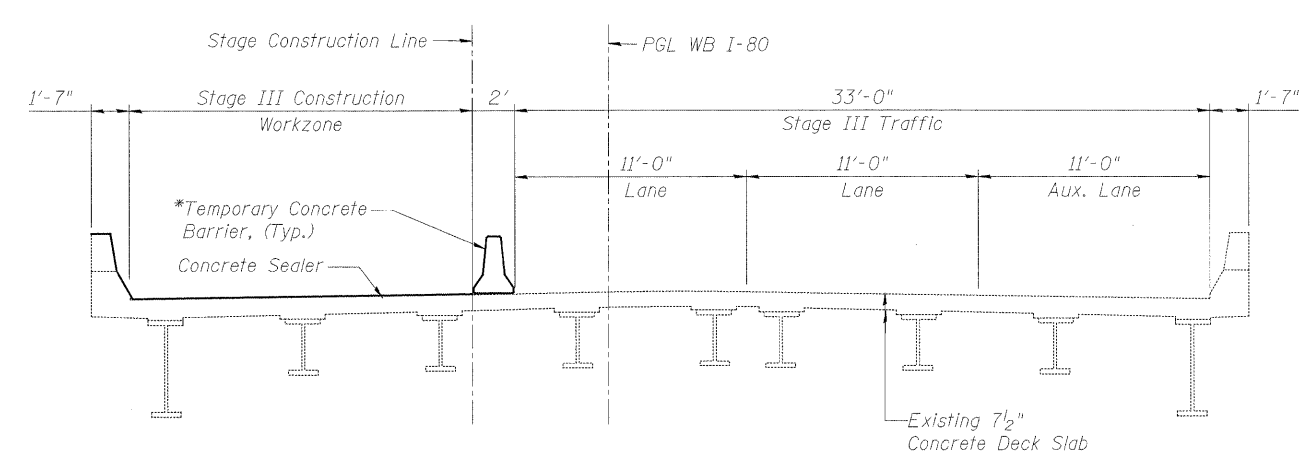

**STAGE III CONSTRUCTION & TRAFFIC**  
(Looking West)

\* A Barricade Type II shall be used in lieu of Temporary Concrete Barrier for closures less than 24 hours. See Roadway Plans for details.

USER NAME =	DESIGNED - GMK	REVISED -	 <b>DR STERLIN CONSULTANTS, INC.</b> 123 N. WACKER DRIVE SUITE 2000 CHICAGO, ILLINOIS 60606 TEL: (312) 957-1000 FAX: (312) 957-1050	<b>STATE OF ILLINOIS</b> <b>DEPARTMENT OF TRANSPORTATION</b>		<b>CONSTRUCTION STAGING</b> <b>WESTBOUND I-80 OVER I-55</b> <b>SN-099-0045</b>		F.A.I. RTE.	SECTION	COUNTY	TOTAL SHEETS	SHEET NO.
PLOT SCALE =	DRAWN - GFP	REVISED -						80	99 (3&4) RS-4	WILL	117	87
PLOT DATE =	CHECKED - WPK/GMK	REVISED -						CONTRACT NO. 60M65				
FILE NAME =	DATE - 01/18/2011	REVISED -						SHEET NO. S-3 OF S-4 SHEETS				
								FED. ROAD DIST. NO. 1 ILLINOIS FED. AID PROJECT				