

PLAN

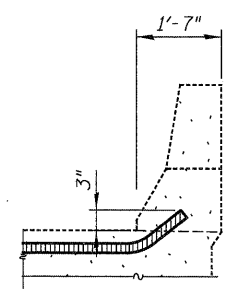

TYPICAL END OF SEAL TREATMENTS

LEGEND:

- Structural Repair of Concrete (Depth < 5")
- Structural Repair of Concrete (Depth > 5")
- Deck Slab Repair (Partial)
- Approach Slab Repair (Partial Depth)
- X** Plug Existing 6" Dia. Deck Drains

BILL OF MATERIAL

| ITEM | UNIT | TOTAL |
|--|--------|-------|
| ** Deck Slab Repair (Partial) | Sq.Yd. | 128 |
| Structural Repair Of Concrete (Depth Equal To Or Less Than 5 inches) | Sq.Ft. | 91 |
| Structural Repair Of Concrete (Depth Greater Than 5 Inches) | Sq.Ft. | 42 |
| Approach Slab Repair (Partial Depth) | Sq.Yd. | 2.7 |
| Plug Existing Deck Drains | Each | 12 |
| Silicone Joint Sealer, 1.75" | Foot | 88 |

** Work shall be performed in accordance with Special Provision Deck Slab Repair (Special)

NOTES:

1. Remove the existing preformed joint seals and replace with silicone joint sealer as detailed in Sections A-A and B-B.
2. Areas of proposed deck repairs are estimated. Actual type, location and dimensions of deck repairs are to be determined by the Engineer during construction.
3. Removal of existing Silicone and Neoprene joint shall be included in the cost of Silicone Joint Sealer, 1.75".
4. Contractor may remove and replace guardrail components to facilitate joint replacement work. Cost included with Silicone Joint Sealer, 1.75".

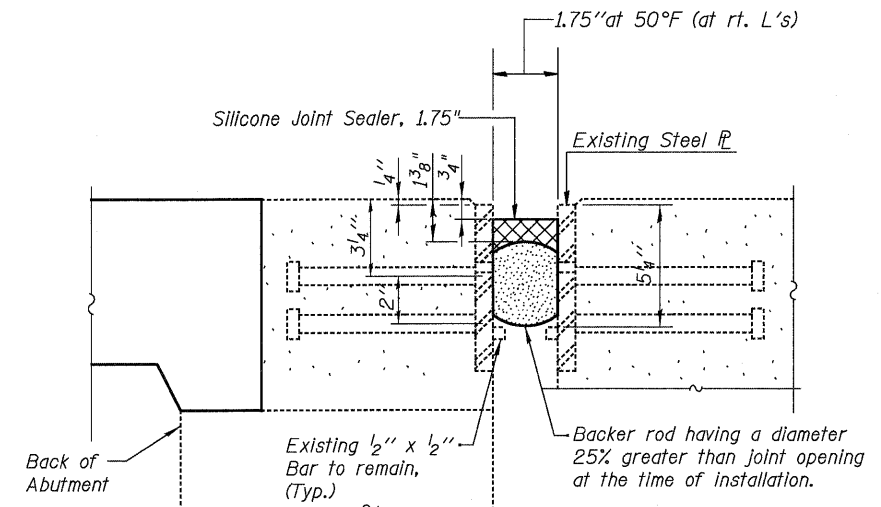

SECTION A-A

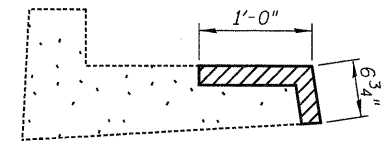

SECTION B-B
Curb Repair SRC < 5"

| | | | | | | | | | | | | |
|--------------|-------------------|-----------|--|---|---------------|--|-----|---------------|---------|--------|--------------|-----------|
| USER NAME = | DESIGNED - GMK | REVISED - | DBS STERLIN CONSULTANTS, INC. 123 N. WACKER DRIVE, SUITE 2000 CHICAGO, ILLINOIS 60606 TEL: (312) 967-1000 FAX: (312) 967-1056 | STATE OF ILLINOIS DEPARTMENT OF TRANSPORTATION | | DECK REPAIR PLAN WESTBOUND I-80 OVER ROCK RUN CREEK SN-099-0047 | | F.A.I. RTE. = | SECTION | COUNTY | TOTAL SHEETS | SHEET NO. |
| PLOT SCALE = | DRAWN - GFP | REVISED - | | 80 | 99 (3&4) RS-4 | WILL | 117 | 90 | | | | |
| PLOT DATE = | CHECKED - WPK/GMK | REVISED - | | CONTRACT NO. 60M65 | | | | | | | | |
| FILE NAME = | DATE - 01/18/2011 | REVISED - | | FED. ROAD DIST. NO. 1 ILLINOIS FED. AID PROJECT | | | | | | | | |