

PIER 11
WEST FACE

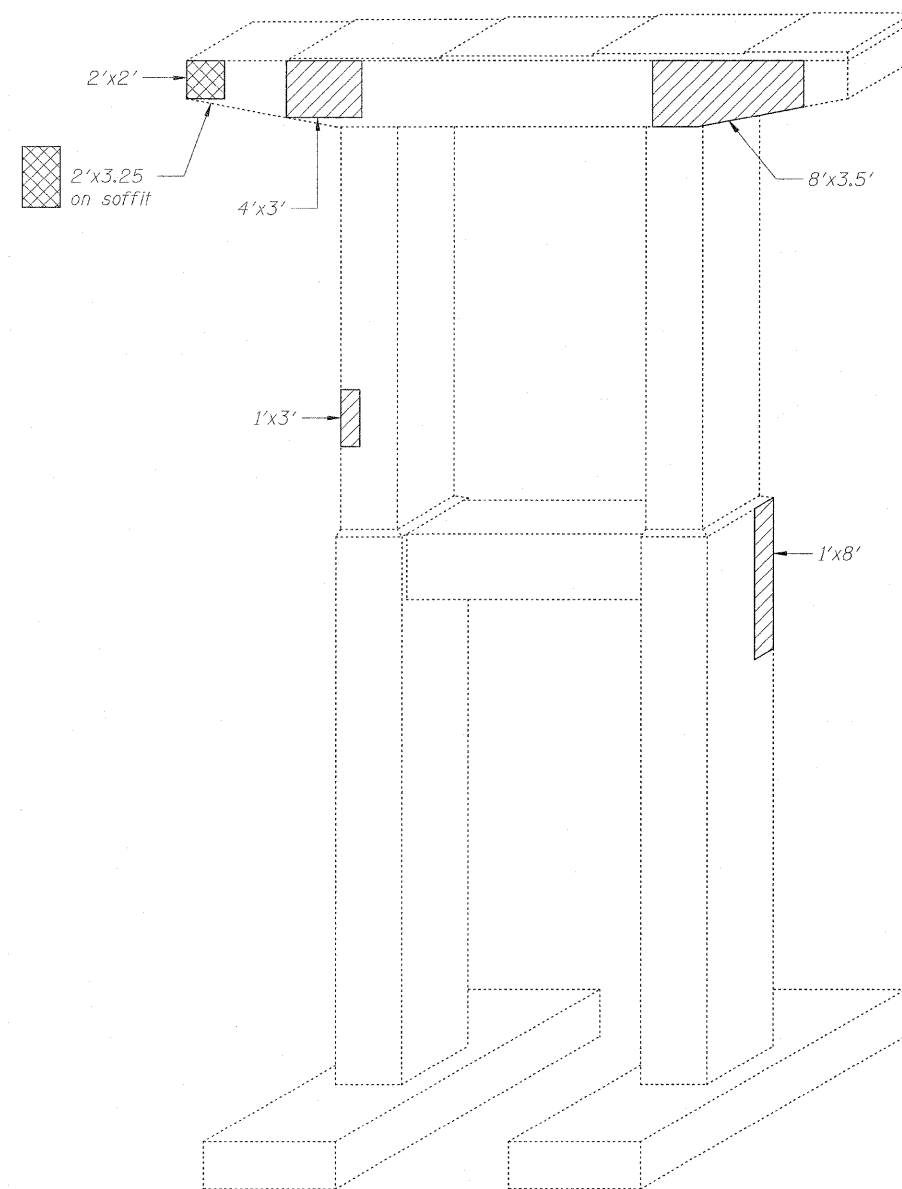

PIER 11
EAST FACE

LEGEND:

- Structural Repair of Concrete (Depth > 5")
- Structural Repair of Concrete (Depth < 5")
- Temporary Shoring and Cribbing

INTERIOR GIRDER REACTION TABLE			
		R1	R2
R ₂	(k)	30.6	33.9
R ₄	(k)	43.2	44.2
Imp.	(k)	12.8	12.8
R _{Total}	(k)	86.5	90.9

BILL OF MATERIAL

ITEM	UNIT	TOTAL
Structural Repair of Concrete (Depth < 5")	Sq. Ft.	137
Structural Repair of Concrete (Depth > 5")	Sq. Ft.	28
Temporary Shoring and Cribbing	Each	2

Note:
See the Special Provision "Temporary Shoring and Cribbing" for design, installation, and removal of the temporary shoring and cribbing support system. Approximate beam reactions are given in Interior Girder Reaction Table at the locations shown.

USER NAME = ayanrigoogl(Rdky_L1s1e)	DESIGNED - A.Y./L.C.	REVISED -		STATE OF ILLINOIS DEPARTMENT OF TRANSPORTATION	PIER 11 REPAIRS WESTBOUND I-80 OVER CNRR AND ROWELL AVENUE SN 099-0067	F.A.I. RTE.	SECTION	COUNTY	TOTAL SHEETS	SHEET NO.
PLOT CONFIG= PDF(I-80_TopoGrey_Large).pl	DRAWN - L.C./A.Y.	REVISED -				80	99 (4&4-1) RS-3	WILL	203	184
PLOT SCALE = 1:5	CHECKED - A.Y./R.L.D.	REVISED -				CONTRACT NO. 60M66				
PLOT DATE = 2/8/2011	DATE - 01/20/2011	REVISED -				FED. ROAD DIST. NO. 1 ILLINOIS FED. AID PROJECT				
SCALE: SHEET 55 of 58 STA. TO STA.										