

TYPICAL SECTION

M.P. 0.00 TO M.P. 1.13
M.P. 1.16 TO M.P. 2.49
M.P. 2.57 TO M.P. 2.84
M.P. 3.02 TO M.P. 4.08
M.P. 4.40 TO M.P. 4.52
M.P. 4.72 TO M.P. 6.46

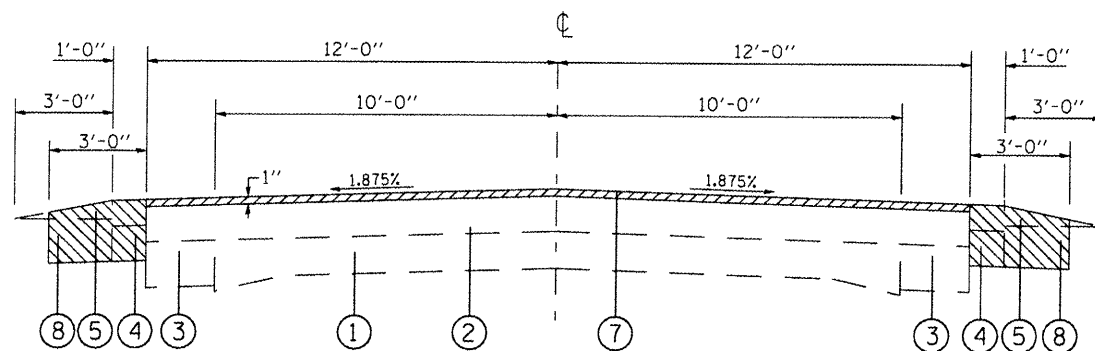

TYPICAL SECTION

M.P. 2.49 TO M.P. 2.57*

LEGEND

- ① EXISTING CONCRETE PAVEMENT 9-6-9
- ② EXISTING RESURFACING, 4 1/2" (8" DEPTH*)
- ③ EXISTING PCC WIDENING, 8"
- ④ EXISTING HMA SHOULDERS, 8" (TO BE REMOVED)
- ⑤ EXISTING AGGREGATE SHOULDER
- ⑥ EXISTING CONC. CURB & GUTTER
- ⑦ PROPOSED HMA SURFACE COURSE REMOVAL
- ⑧ PROPOSED EXCAVATING AND GRADING EXISTING SHOULDERS
- ⑨ PROPOSED BITUMINOUS MATERIALS (PRIME COAT)
- ⑩ PROPOSED AGGREGATE (PRIME COAT)
- ⑪ PROPOSED LEVELING BINDER, 3/4 "
- ⑫ PROPOSED SURFACE COURSE, 1 1/2"
- ⑬ PROPOSED HOT-MIX ASPHALT SHOULDER, 9 1/4"
- ⑭ PROPOSED SUBBASE GRANULAR MATERIAL, TYPE C, 4"
- ⑮ PROPOSED STRIP REFLECTIVE CRACK CONTROL
- ⑯ PROPOSED AGGREGATE WEDGE SHOULDER, TYPE B

NOTE:
THE INTENT OF THE MILLING IS TO REMOVE
HMA SURFACE MATERIAL ONLY. THE UNDERLYING
CONCRETE PAVEMENT SHALL NOT BE DISTURBED.

FILE NAME :	USER NAME : #USER#	DESIGNED -	REVISED -	STATE OF ILLINOIS DEPARTMENT OF TRANSPORTATION	EXISTING TYPICALS	F.A.P. RTE.	SECTION	COUNTY	TOTAL SHEETS	SHEET NO.
#FILE#		DRAWN -	REVISED -			42	(130,1)RS-5	CLINTON	26	6
		CHECKED -	REVISED -			CONTRACT NO. 76E11		FED. ROAD DIST. NO. ILLINOIS FED. AID PROJECT		
		PLOT SCALE : #SCALE#	DATE	SCALE:	SHEET NO. OF SHEETS	STA.	TO STA.			