

STATE OF ILLINOIS  
DEPARTMENT OF TRANSPORTATION

# PROPOSED HIGHWAY PLANS

FAS ROUTE 323 & FAP ROUTE 71 (IL 54)  
SECTION (112&112Z)&(38-5HB-4)RS-3,SW  
PROJECT STP - Z1KQ(351)  
MILLING AND RESURFACING, ADA  
IROQUOIS COUNTY

C-93-080-21

F.A.P. RTE.	SECTION	COUNTY	TOTAL SHEETS	SHEET NO.
71	(112&112Z)&(38-5HB-4)RS-3,SW	IROQUOIS	40	1
ILLINOIS			CONTRACT NO. 66K77	

D-93-044-21

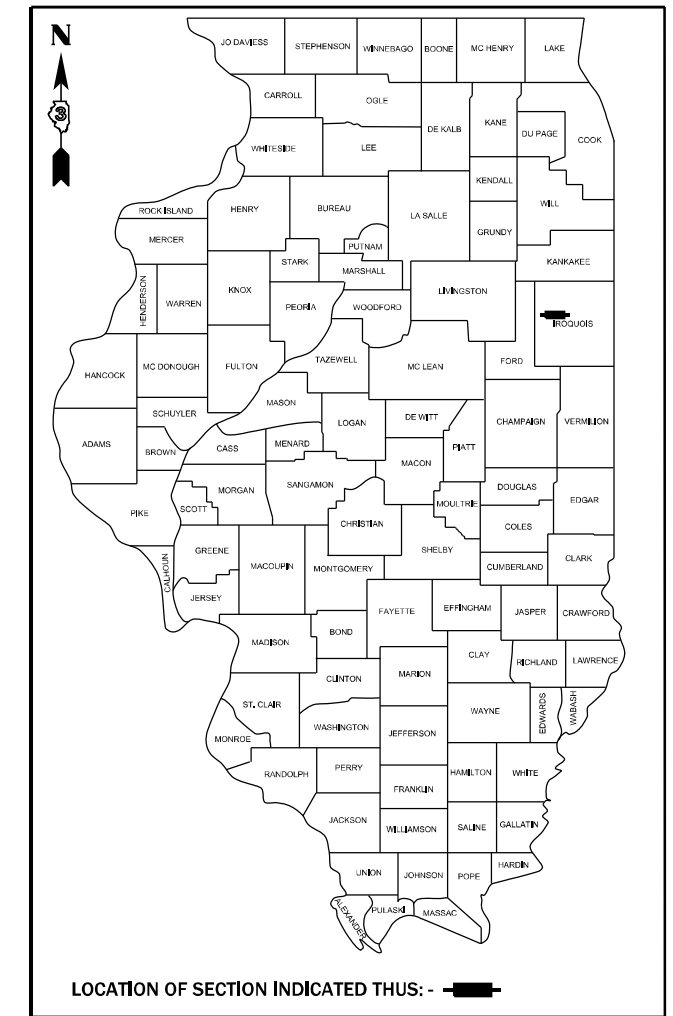

**INDEX**

- 1 COVER SHEET
- 2 GENERAL NOTES
- 3-7 SUMMARY OF QUANTITIES
- 8-9 TYPICAL SECTIONS
- 10-14 SCHEDULES
- 15 LAYOUT MAP
- 16-36 ADA DETAILS
- 37-40 DETAILS

**LIST OF ILLINOIS DOT HIGHWAY STANDARDS**

- 000001-08 STANDARD SYMBOLS, ABBREVIATIONS AND PATTERNS
- 001006 DECIMAL OF AN INCH AND OF A FOOT
- 406201-01 MAILBOX TURNOUT
- 424001-11 PERPENDICULAR CURB RAMPS FOR SIDEWALKS
- 424006-05 DIAGONAL CURB RAMPS FOR SIDEWALKS
- 424011-04 CORNER PARALLEL CURB RAMPS FOR SIDEWALKS
- 424021-06 DEPRESSED CORNER FOR SIDEWALKS
- 424026-03 ENTRANCE / ALLEY PEDESTRIAN CROSSINGS
- 667101-02 PERMANENT SURVEY MARKERS
- 701006-05 OFF-ROAD OPERATIONS 2L, 2W, 15' (4.5 m) TO 24" (600 mm) FROM PAVEMENT EDGE
- 701011-04 OFF-ROAD MOVING OPERATIONS 2L, 2W, DAY ONLY
- 701201-05 LANE CLOSURE, 2L, 2W, DAY ONLY, FOR SPEEDS ≥ 45 MPH
- 701301-04 LANE CLOSURE, 2L, 2W, SHORT TIME OPERATIONS
- 701306-04 LANE CLOSURE, 2L, 2W, SLOW MOVING OPERATIONS DAY ONLY, FOR SPEEDS ≥ 45 MPH
- 701311-03 LANE CLOSURE, 2L, 2W, MOVING OPERATIONS - DAY ONLY
- 701501-06 URBAN LANE CLOSURE, 2L, 2W, UNDIVIDED
- 701801-06 SIDEWALK, CORNER OR CROSSWALK CLOSURE
- 701901-08 TRAFFIC CONTROL DEVICES
- 780001-05 TYPICAL PAVEMENT MARKINGS
- 781001-04 TYPICAL APPLICATIONS RAISED REFLECTIVE PAVEMENT MARKERS

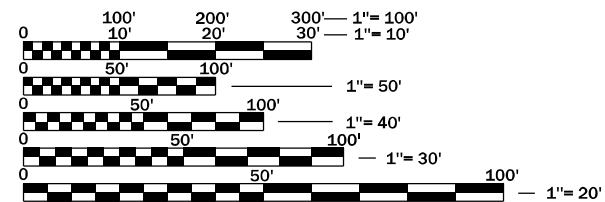
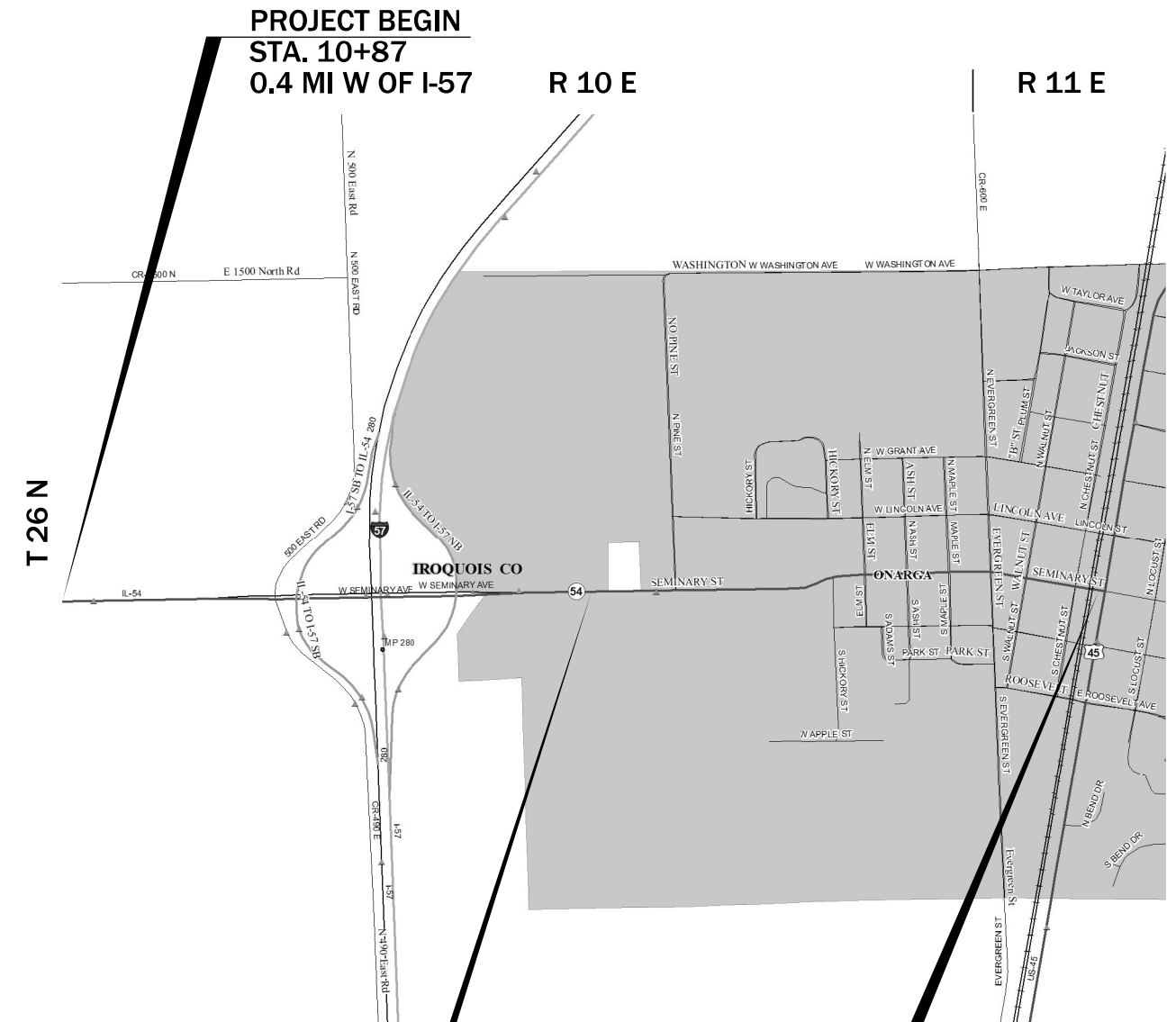

FULL SIZE PLANS HAVE BEEN PREPARED USING STANDARD ENGINEERING SCALES. REDUCED SIZED PLANS WILL NOT CONFORM TO STANDARD SCALES. IN MAKING MEASUREMENTS ON REDUCED PLANS, THE ABOVE SCALES MAY BE USED.

J.U.L.I.E.  
JOINT UTILITY LOCATION INFORMATION FOR EXCAVATION  
1-800-892-0123  
OR 811

**PROJECT ENGINEER: BRAD DUNCAN P.E.**  
**UNIT CHIEF: DARCY CARPENTER**  
DISTRICT 3 NO. (815) 434-6131  
CONTRACT NO. 66K77

**STATION EQUATION**  
STA. 48+44.98BK = 42+92.89AH

**PROJECT END**  
STA. 0+65  
US 45 IN ONARGA

GROSS LENGTH = 7985.87 FT. = 1.512 MILE  
NET LENGTH = 7985.87 FT. = 1.512 MILE

**MAJOR COLLECTOR**  
**2019 ADT=1950**

**PV=98.9% SU=0.80% MU=0.30%**

STATE OF ILLINOIS  
DEPARTMENT OF TRANSPORTATION

SUBMITTED December 15, 20 21

*David Almed*  
REGIONAL ENGINEER

February 4, 20 22  
*[Signature]*  
ENGINEER OF DESIGN AND ENVIRONMENT

February 4, 20 22  
*Stephen M. Smith*  
DIRECTOR OF HIGHWAYS PROJECT IMPLEMENTATION

**PRINTED BY THE AUTHORITY  
OF THE STATE OF ILLINOIS**

**GENERAL NOTES**

THE HMA SURFACE OF ALL MAILBOX TURNOUTS, PRIVATE ENTRANCES, COMMERCIAL ENTRANCES, AND SIDE ROADS SHALL BE MADE NEATLY, IN A WORKMANLIKE MANNER, AND SHALL ACCURATELY CONFORM TO THE SHAPES AND DIMENSIONS SHOWN ON THE PLAN DETAILS. IF REQUIRED BY THE ENGINEER, THE CONTRACTOR SHALL SAW CUT THE HMA SURFACE TO CONFORM TO THE SHAPES AND DIMENSIONS SHOWN ON THE PLAN DETAILS. THIS WORK WILL BE INCLUDED IN THE COST OF THE HMA SURFACE.

EXCEPT AS NOTED ON THE PLANS, PAVEMENT GRADES SHOWN ARE AT THE TOP OF PAVEMENT SURFACES.

THE ENGINEER WILL BE THE SOLE JUDGE CONCERNING CURING TIME FOR THE VARIOUS HMA LIFTS.

ON EXISTING PAVEMENT WHICH MAY BE SUPERELEVATED, THE NEW HMA PAVEMENT SHALL BE BUILT WITH THE SAME SUPERELEVATION UNLESS NEW SUPERELEVATION RATES ARE GIVEN ON THE PLANS.

ALL ELEVATIONS REFERRING TO U.S.G.S. MEAN SEA LEVEL DATUM.

THE FOLLOWING RATES OF APPLICATION HAVE BEEN USED IN CALCULATING PLAN QUANTITIES:

GRANULAR MATERIALS	2.05	TONS / CU YD
HMA RESURFACING	112	LBS / SQ YD / IN
SHORT TERM PAVEMENT MARKING	10	FT /100 FT OF APPLICATION
MIX FOR CRACKS, JTS & FLGWYS	0.0003	TONS / SQ YD
BINDER (HAND METHOD)	0.0005	TONS / SQ YD
SUPPLEMENTAL WATERING	3	GAL / SQ YD / APPLICATION
CALCIUM CHLORIDE	2	LB / SQ YD / APPLICATION
AGGREGATE DITCH CHECKS	5	TONS AGGREGATE

MEMBERS OF JULIE KNOWN TO BE WITHIN THE LIMITS OF THE IMPROVEMENT ARE: AMEREN, AT&T, COMCAST, CMS, WINDSTREAM, METRO COMMUNICATIONS, NICOR, AND THE VILLAGE OF ONARGA

NON MEMBERS OF JULIE KNOWN TO BE WITHIN THE LIMITS OF THE IMPROVEMENT ARE: IDOT

THE CONTRACTOR SHALL CONTACT JULIE AT LEAST 48 HOURS PRIOR TO EXCAVATION TO DETERMINE WHICH UTILITIES ARE IN THE AREA.

HMA MIXTURE REQUIREMENT TABLE				
LOCATIONS:	STA 10+87 TO 25+77	STA 25+77 TO 0+65	ENTIRE PROJECT	ENTIRE PROJECT
MIXTURE USE(S):	HMA BINDER COURSE	HMA BINDER COURSE	HMA SURFACE COURSE	INCIDENTAL HMA
BINDER GRADE (PG):	PG 64-22	PG 64-22	PG 64-22	PG 64-22
DESIGN AIR VOIDS:	4.0% @ N50	4.0% @ N50	4.0% @ N50	4.0% @ N50
MIXTURE COMPOSITION: (MIXTURE GRADATION)	IL-19.0	IL-9.5FG	IL-9.5	IL-9.5
FRICTION AGGREGATE:	N/A	N/A	MIXTURE C	MIXTURE C
MIXTURE WEIGHT:	112.0 LB/SY/IN	112.0 LB/SY/IN	112.0 LB/SY/IN	112.0 LB/SY/IN
QUALITY MANAGEMENT PROGRAM:	QCP	QC/QA	QCP	QC/QA
SUBLOT SIZE:	1000 TONS	N/A	1000 TONS	N/A
DENSITY TEST METHOD:	CORES	CORES	CORES	SATISFACTION OF THE ENGINEER
MATERIAL TRANSFER DEVICE (REQUIRED)	YES	YES	YES	NO

STATE OF ILLINOIS  
DEPARTMENT OF TRANSPORTATION  
DISTRICT THREE  
AS BUILT INFORMATION

STATE OF ILLINOIS  
DEPARTMENT OF TRANSPORTATION  
DISTRICT THREE

\_\_\_\_\_  
SUPERVISING CONSTRUCTION FIELD ENGINEER

PREPARED BY: \_\_\_\_\_  
DISTRICT STUDIES & PLANS ENGINEER

\_\_\_\_\_  
RESIDENT ENGINEER / TECHNICIAN

DATE: \_\_\_\_\_

START & END DATES  
OF CONSTRUCTION:

\_\_\_\_\_

EXAMINED BY: \_\_\_\_\_  
DISTRICT CONSTRUCTION ENGINEER

INSPECTORS: \_\_\_\_\_

\_\_\_\_\_

\_\_\_\_\_  
DISTRICT MATERIALS ENGINEER

\_\_\_\_\_  
DISTRICT OPERATIONS ENGINEER

\* FAS 323 / FAP 71  
\*\* (112&112Z)&(38-5HB-4)RS-3,SW

MODEL: Default  
FILE: \\blmfe-pw-bentley.com\P\DOT\Documents\DOT Office\District 3\Project\3166677\Cadd\3166677-plr-cover.dgn

USER NAME = pletschr	DESIGNED - _____	REVISED - _____
DRAWN - _____	REVISOR - _____	REVISOR - _____
PLOT SCALE = 100,0000 ' / in.	CHECKED - _____	REVISOR - _____
PLOT DATE = 12/15/2021	DATE - _____	REVISOR - _____

**STATE OF ILLINOIS  
DEPARTMENT OF TRANSPORTATION**

**GENERAL NOTES**

SCALE: \_\_\_\_\_ SHEET \_\_\_ OF \_\_\_ SHEETS STA. \_\_\_\_\_ TO STA. \_\_\_\_\_

F.A.* RTE.	SECTION	COUNTY	TOTAL SHEETS	SHEET NO.
**	**	IROQUOIS	40	2
CONTRACT NO. 66K77				
ILLINOIS FED. AID PROJECT				



CODE NO.	ITEM	UNIT	TOTAL QUANTITY	CONSTRUCTION CODE			
				80%FED/20%STATE STP-R FAP 71	80%FED/20%STATE STP-R FAS 323	80%FED/20%VILLAGE STP-R FAS 323	50%FED/50%VILLAGE STP-R FAS 323
				ROADWAY 0005	ROADWAY 0005	SAFETY 0021	ROADWAY 0005
				RURAL	RURAL	RURAL	RURAL
20200100	EARTH EXCAVATION	CU YD	2		2		
20400800	FURNISHED EXCAVATION	CU YD	4	3	1		
21400100	GRADING AND SHAPING DITCHES	FOOT	555		555		
25000210	SEEDING, CLASS 2A	ACRE	0.21	0.14	0.07		
25000400	NITROGEN FERTILIZER NUTRIENT	POUND	20	17	3		
25000500	PHOSPHORUS FERTILIZER NUTRIENT	POUND	20	17	3		
25000600	POTASSIUM FERTILIZER NUTRIENT	POUND	20	17	3		
25100630	EROSION CONTROL BLANKET	SQ YD	1031	887	144		
35600708	HOT-MIX ASPHALT BASE COURSE WIDENING, 3"	SQ YD	6		6		
40600290	BITUMINOUS MATERIALS (TACK COAT)	POUND	23346	7873	15473		
40600370	LONGITUDINAL JOINT SEALANT	FOOT	10634	624	10010		
40600400	MIXTURE FOR CRACKS, JOINTS, AND FLANGEWAYS	TON	7	2	5		
40600900	HOT-MIX ASPHALT BINDER COURSE (HAND METHOD), N50	TON	7	3	4		
40600990	TEMPORARY RAMP	SQ YD	891	232	659		

MODEL: Default  
 FILE: \\bluelc-pw-beadley.com\P\DOT\Documents\DOT Office\District 3\Project\356677\CADD\data\CAD\Fees\356677-rhc-cover.dgn

\* FAS 323 / FAP 71  
 \*\* (112&112Z)&(38-5HB-4)RS-3,SW

USER NAME = pletschr	DESIGNED - _____	REVISED - _____
PLOT SCALE = 100,0000' / in.	CHECKED - _____	REVISED - _____
PLOT DATE = 1/3/2022	DATE - _____	REVISED - _____

**STATE OF ILLINOIS  
 DEPARTMENT OF TRANSPORTATION**

**SUMMARY OF QUANTITIES**

SCALE: \_\_\_\_\_ SHEET \_\_\_\_ OF \_\_\_\_ SHEETS STA. \_\_\_\_\_ TO STA. \_\_\_\_\_

F.A.* RTE.	SECTION	COUNTY	TOTAL SHEETS	SHEET NO.
*	**	IROQUOIS	40	3
CONTRACT NO. 66K77				
ILLINOIS FED. AID PROJECT				

CODE NO.	ITEM	UNIT	TOTAL QUANTITY	CONSTRUCTION CODE			
				80%FED/20%STATE STP-R FAP 71	80%FED/20%STATE STP-R FAS 323	80%FED/20%VILLAGE STP-R FAS 323	50%FED/50%VILLAGE STP-R FAS 323
				ROADWAY 0005 RURAL	ROADWAY 0005 RURAL	SAFETY 0021 RURAL	ROADWAY 0005 RURAL
40602965	HOT-MIX ASPHALT BINDER COURSE, IL-9.5FG, N50	TON	477		477		
40603080	HOT-MIX ASPHALT BINDER COURSE, IL-19.0, N50	TON	2883	1422	1461		
40604050	HOT-MIX ASPHALT SURFACE COURSE, IL-9.5, MIX "C", N50	TON	3629	1428	1753		448
40800050	INCIDENTAL HOT-MIX ASPHALT SURFACING	TON	407	103	304		
42400100	PORTLAND CEMENT CONCRETE SIDEWALK 4 INCH	SQ FT	4045		4045		
* 42400800	DETECTABLE WARNINGS	SQ FT	274		274		
44000100	PAVEMENT REMOVAL	SQ YD	440		440		
44000159	HOT-MIX ASPHALT SURFACE REMOVAL, 2 1/2"	SQ YD	6865		6865		
44000164	HOT-MIX ASPHALT SURFACE REMOVAL, 3 3/4"	SQ YD	25099	10942	14157		
44000500	COMBINATION CURB AND GUTTER REMOVAL	FOOT	458		458		
44000600	SIDEWALK REMOVAL	SQ FT	3383		3097	286	
48102100	AGGREGATE WEDGE SHOULDER, TYPE B	TON	332	145	187		
60605000	COMBINATION CONCRETE CURB AND GUTTER, TYPE B-6.24	FOOT	515		515		
* 66700205	PERMANENT SURVEY MARKERS, TYPE I	EACH	1		1		

\*= SPECIALTY ITEM

MODEL: Default  
FILE: \\na11c:\pub\lisset-paw-beauley.com\PIV\DOT\Documents\1\DOT Office\Dir\Dir: 3\Project\1\366677\CADD\data\CAD\Preest\1\366677-rlt-cover.dgn

\* FAS 323 / FAP 71  
\*\* (112&112Z)&(38-5HB-4)RS-3,SW

USER NAME = pletschr	DESIGNED - _____	REVISED - _____
PLOT SCALE = 100,0000' / in.	CHECKED - _____	REVISED - _____
PLOT DATE = 1/3/2022	DATE - _____	REVISED - _____

**STATE OF ILLINOIS  
DEPARTMENT OF TRANSPORTATION**

**SUMMARY OF QUANTITIES**

SCALE: \_\_\_\_\_ SHEET \_\_\_\_ OF \_\_\_\_ SHEETS STA. \_\_\_\_\_ TO STA. \_\_\_\_\_

F.A.* RTE.	SECTION	COUNTY	TOTAL SHEETS	SHEET NO.
*	**	IROQUOIS	40	4
			CONTRACT NO. 66K77	
			ILLINOIS FED. AID PROJECT	

CODE NO.	ITEM	UNIT	TOTAL QUANTITY	CONSTRUCTION CODE			
				80%FED/20%STATE STP-R FAP 71	80%FED/20%STATE STP-R FAS 323	80%FED/20%VILLAGE STP-R FAS 323	50%FED/50%VILLAGE STP-R FAS 323
				ROADWAY 0005 RURAL	ROADWAY 0005 RURAL	SAFETY 0021 RURAL	ROADWAY 0005 RURAL
* 66900200	NON-SPECIAL WASTE DISPOSAL	CU YD	36		36		
* 66900530	SOIL DISPOSAL ANALYSIS	EACH	2		2		
* 66901001	REGULATED SUBSTANCES PRE-CONSTRUCTION PLAN	L SUM	1		1		
* 66901003	REGULATED SUBSTANCES FINAL CONSTRUCTION REPORT	L SUM	1		1		
* 66901006	REGULATED SUBSTANCES MONITORING	CAL DA	3		3		
67000400	ENGINEER'S FIELD OFFICE, TYPE A	CAL MO	6	2	4		
67100100	MOBILIZATION	L SUM	1	0.25	0.75		
70100460	TRAFFIC CONTROL AND PROTECTION, STANDARD 701306	L SUM	1	0.25	0.75		
70102620	TRAFFIC CONTROL AND PROTECTION, STANDARD 701501	L SUM	1		1		
70102640	TRAFFIC CONTROL AND PROTECTION, STANDARD 701801	L SUM	1		1		
70300100	SHORT TERM PAVEMENT MARKING	FOOT	1972	150	1822		
70300150	SHORT TERM PAVEMENT MARKING REMOVAL	SQ FT	623	18	605		
* 78000100	THERMOPLASTIC PAVEMENT MARKING - LETTERS AND SYMBOLS	SQ FT	301	89	212		
* 78000200	THERMOPLASTIC PAVEMENT MARKING - LINE 4"	FOOT	16528	5821	10707		

\*= SPECIALTY ITEM

MODEL: Default  
FILE: \\blm\p\project\paw\benefit\com\PIV\DOT\Documents\DOT Office\Dir\Dir: 3\Project\0366677\CADD\DATA\CAD\Sheet\0366677-01-01-cover.dgn

\* FAS 323 / FAP 71  
\*\* (112&112Z)&(38-5HB-4)RS-3,SW

USER NAME = pletschr	DESIGNED - _____	REVISED - _____
PLOT SCALE = 100,0000' / in.	DRAWN - _____	REVISIED - _____
PLOT DATE = 1/3/2022	CHECKED - _____	REVISIED - _____
	DATE - _____	REVISIED - _____

**STATE OF ILLINOIS  
DEPARTMENT OF TRANSPORTATION**

**SUMMARY OF QUANTITIES**

SCALE: \_\_\_\_\_ SHEET \_\_\_\_ OF \_\_\_\_ SHEETS STA. \_\_\_\_\_ TO STA. \_\_\_\_\_

F.A.* RTE.	SECTION	COUNTY	TOTAL SHEETS	SHEET NO.
*	**	IROQUOIS	40	5
			CONTRACT NO. 66K77	
			ILLINOIS FED. AID PROJECT	

CODE NO.	ITEM	UNIT	TOTAL QUANTITY	CONSTRUCTION CODE			
				80%FED/20%STATE STP-R FAP 71	80%FED/20%STATE STP-R FAS 323	80%FED/20%VILLAGE STP-R FAS 323	50%FED/50%VILLAGE STP-R FAS 323
				ROADWAY 0005	ROADWAY 0005	SAFETY 0021	ROADWAY 0005
				RURAL	RURAL	RURAL	RURAL
* 78000400	THERMOPLASTIC PAVEMENT MARKING - LINE 6"	FOOT	1185		1185		
* 78000500	THERMOPLASTIC PAVEMENT MARKING - LINE 8"	FOOT	796	388	408		
* 78000600	THERMOPLASTIC PAVEMENT MARKING - LINE 12"	FOOT	500	117	383		
* 78000650	THERMOPLASTIC PAVEMENT MARKING - LINE 24"	FOOT	160	44	116		
* 78001110	PAINT PAVEMENT MARKING - LINE 4"	FOOT	16266	3330	12936		
* 78001130	PAINT PAVEMENT MARKING - LINE 6"	FOOT	1080		1080		
* 78011000	GROOVING FOR RECESSED PAVEMENT MARKING, LETTERS AND SYMBOLS	SQ FT	303	90	213		
* 78011025	GROOVING FOR RECESSED PAVEMENT MARKING 5"	FOOT	16528	5821	10707		
* 78011035	GROOVING FOR RECESSED PAVEMENT MARKING 7"	FOOT	1185		1185		
* 78011045	GROOVING FOR RECESSED PAVEMENT MARKING 9"	FOOT	796	388	408		
* 78011065	GROOVING FOR RECESSED PAVEMENT MARKING 13"	FOOT	58	26	32		
* 78011125	GROOVING FOR RECESSED PAVEMENT MARKING 25"	FOOT	160	44	116		
* 78100100	RAISED REFLECTIVE PAVEMENT MARKER	EACH	82	6	76		
78300200	RAISED REFLECTIVE PAVEMENT MARKER REMOVAL	EACH	82	6	76		

\*= SPECIALTY ITEM

MODEL: Default  
FILE NAME: p:\ultra\paw\benefy.com\PIV\DOT\Documents\DOT Office\Dir\dir: 3\Project\366677\CADD\data\CAD\Faces\366677-rlt-cover.dgn

\* FAS 323 / FAP 71  
\*\* (112&112Z)&(38-5HB-4)RS-3,SW

USER NAME = pletschr	DESIGNED - _____	REVISED - _____
PLOT SCALE = 100,0000' / in.	DRAWN - _____	REVISIED - _____
PLOT DATE = 1/3/2022	CHECKED - _____	REVISIED - _____
	DATE - _____	REVISIED - _____

**STATE OF ILLINOIS  
DEPARTMENT OF TRANSPORTATION**

**SUMMARY OF QUANTITIES**

SCALE: \_\_\_\_\_ SHEET \_\_\_\_ OF \_\_\_\_ SHEETS STA. \_\_\_\_\_ TO STA. \_\_\_\_\_

F.A.* RTE.	SECTION	COUNTY	TOTAL SHEETS	SHEET NO.
*	**	IROQUOIS	40	6
			CONTRACT NO. 66K77	
			ILLINOIS FED. AID PROJECT	

CODE NO.	ITEM	UNIT	TOTAL QUANTITY	CONSTRUCTION CODE			
				80%FED/20%STATE STP-R FAP 71	80%FED/20%STATE STP-R FAS 323	80%FED/20%VILLAGE STP-R FAS 323	50%FED/50%VILLAGE STP-R FAS 323
				ROADWAY 0005	ROADWAY 0005	SAFETY 0021	ROADWAY 0005
				RURAL	RURAL	RURAL	RURAL
X0320050	CONSTRUCTION LAYOUT (SPECIAL)	L SUM	1		1		
X4401198	HOT-MIX ASPHALT SURFACE REMOVAL, VARIABLE DEPTH	SQ YD	7439	917	2715		3807
X5619210	WATER VALVES TO BE ADJUSTED, SPECIAL	EACH	1		1		
X6030310	FRAMES AND LIDS TO BE ADJUSTED (SPECIAL)	EACH	9		9		
X7010239	CHANGEABLE MESSAGE SIGN, SPECIAL	CAL WK	4	2	2		
X7010520	TRAFFIC CONTROL AND PROTECTION, STANDARD 701201 (SPECIAL)	L SUM	1	0.5	0.5		
Z0000100	ABANDON EXISTING CULVERT	EACH	1		1		
Z0004556	HOT-MIX ASPHALT SURFACE REMOVAL (DECK)	SQ YD	925	469	456		
Z0030850	TEMPORARY INFORMATION SIGNING	SQ FT	42	21	21		
Z0034105	MATERIAL TRANSFER DEVICE	TON	7138	2736	4402		
Z0048665	RAILROAD PROTECTIVE LIABILITY INSURANCE	L SUM	1		1		

MODEL: Default  
 FILE NAME: p:\u0000\paw\_bentley.com\PW\DOT\Documents\DOT Office\Dir\rdt\_3\Project\0366677\CADD\data\CAD\Faces\0366677-rlt-cover.dgn

USER NAME = pletschr	DESIGNED - _____	REVISED - _____
PLOT SCALE = 100,0000' / in.	CHECKED - _____	REVISED - _____
PLOT DATE = 1/3/2022	DATE - _____	REVISED - _____

**STATE OF ILLINOIS  
DEPARTMENT OF TRANSPORTATION**

**SUMMARY OF QUANTITIES**

SCALE: \_\_\_\_\_ SHEET \_\_\_ OF \_\_\_ SHEETS STA. \_\_\_\_\_ TO STA. \_\_\_\_\_

F.A.* RTE.	SECTION	COUNTY	TOTAL SHEETS	SHEET NO.
*	**	IROQUOIS	40	7
			CONTRACT NO. 66K77	
			ILLINOIS FED. AID PROJECT	

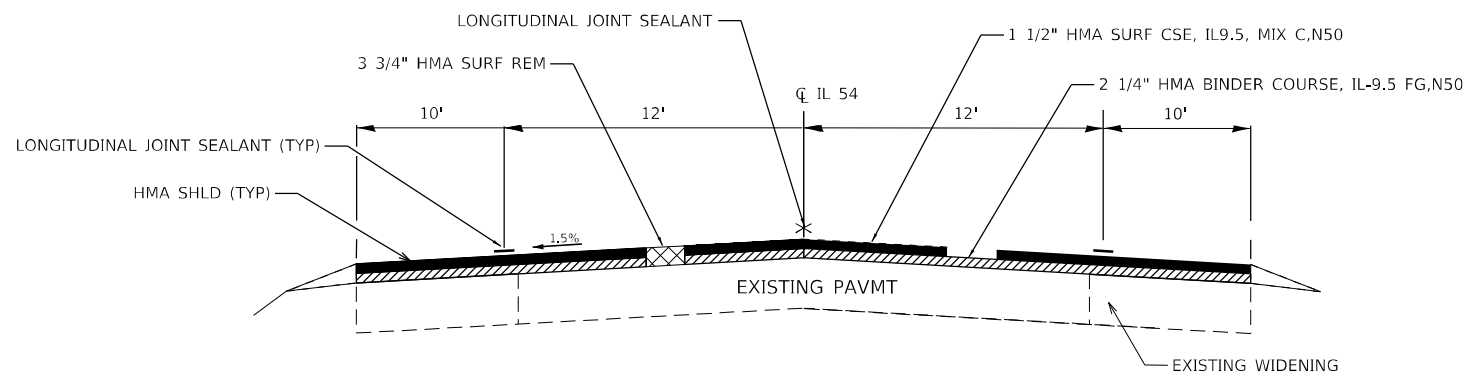

**TYPICAL SECTION 1**

STA 10+86 TO STA 17+11  
 STA 40+79 TO STA 48+44.98  
 \* STATION EQUATION STA 48+44.98 BK =  
 STA 42+92.89 AH

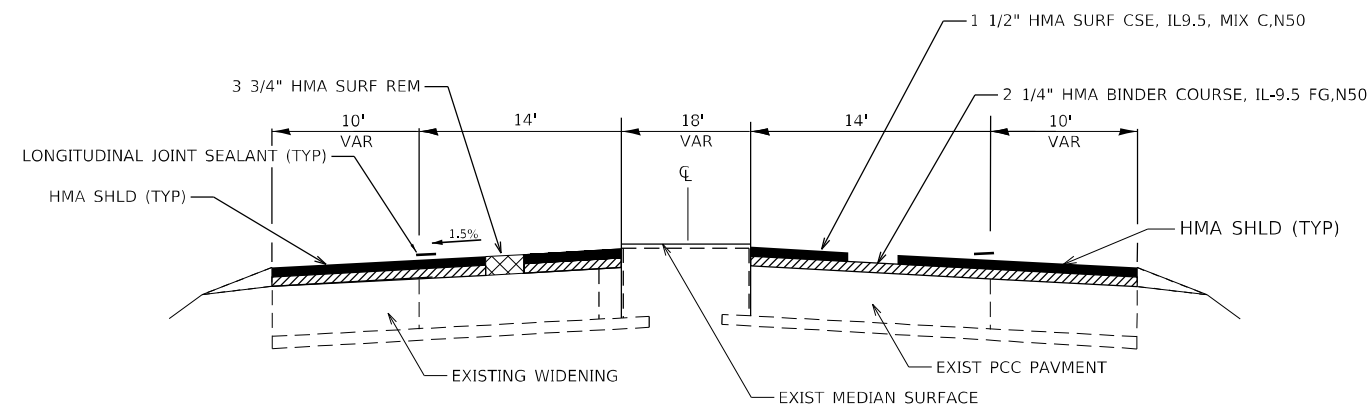

**TYPICAL SECTION 2**

STA 17+11 TO STA 28+57  
 STA 28+89 TO STA 31+08  
 STA 31+38 TO STA 40+79

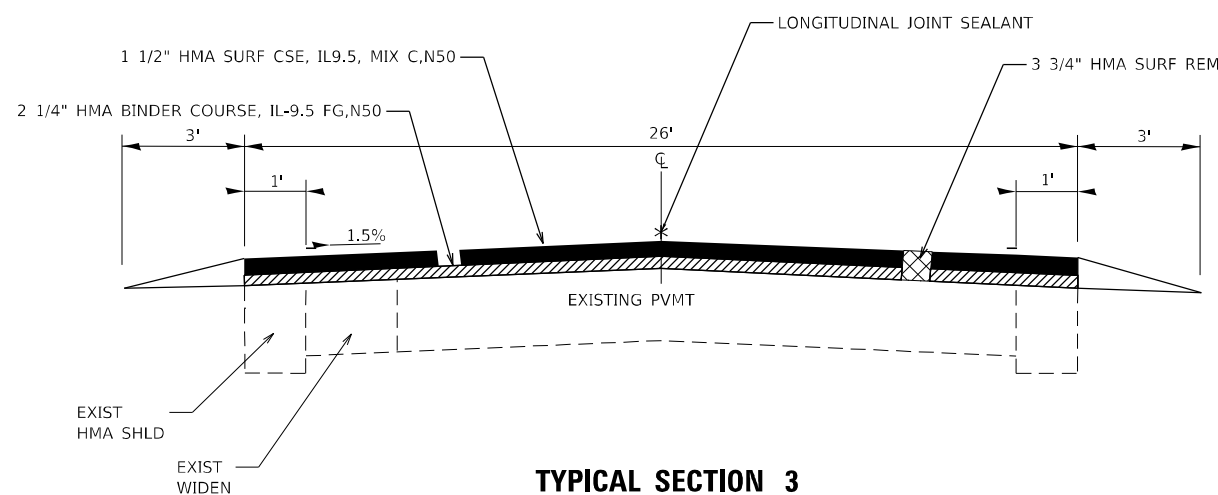

**TYPICAL SECTION 3**

STA 42+93 TO STA 36+84

**NOTE: REMOVE EXISTING HMA DOWN TO BARE CONCRETE  
 (FROM HICKORY ST TO CHESTNUT ST)**

\* FAS 323 / FAP 71  
 \*\* (112&112Z)S(38-5HB-4)RS-3,SW

MODEL: Default  
 FILE: Model: Plots\Auto-plot.bentley.com\p1\VIDOT\Documents\TDOT\_C\Projects\30366627\CADD\AS\AS\Drawings\30366627-shs-typical.dgn

STATE OF ILLINOIS DEPARTMENT OF TRANSPORTATION				TYPICAL SECTIONS		F.A. RTE.	SECTION	COUNTY	TOTAL SHEETS	SHEET NO.
USER NAME = pletschr	DESIGNED - _____	REVISED - _____	SCALE: _____	SHEET _____ OF _____ SHEETS	STA. _____ TO STA. _____	*	**	IROQUOIS	40	8
PLOT SCALE = 100.0421' / in.	CHECKED - _____	REVISED - _____				CONTRACT NO. 66K77				
PLOT DATE = 12/15/2021	DATE - _____	REVISED - _____				ILLINOIS FED. AID PROJECT				

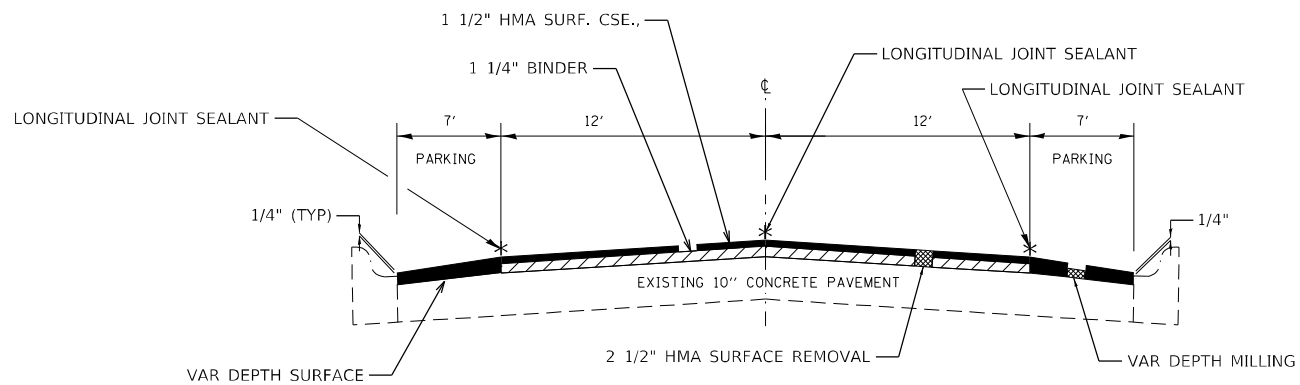

**TYPICAL SECTION 4**  
 STA 22+82 TO STA 0+00

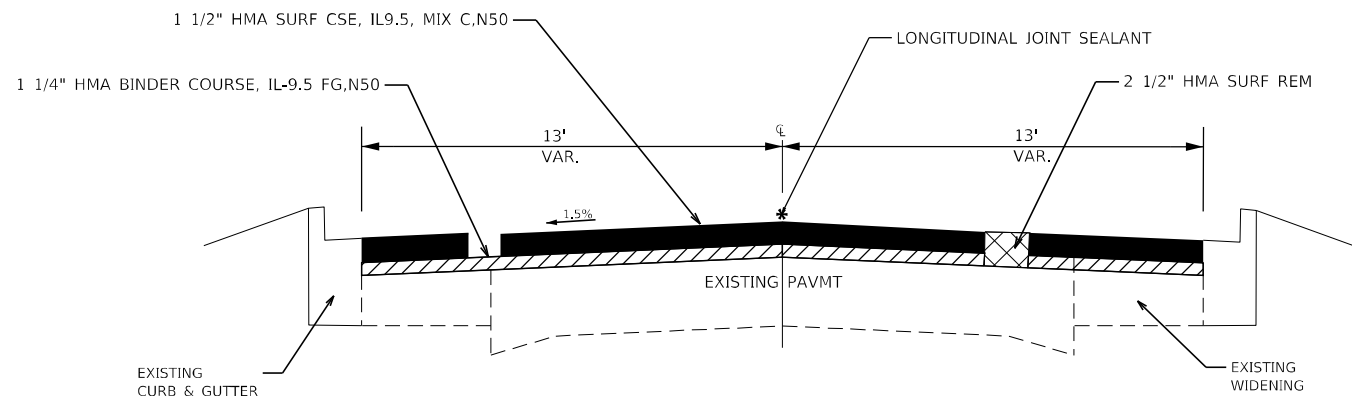

**TYPICAL SECTION 6**  
 STA 36+49 TO STA 25+77

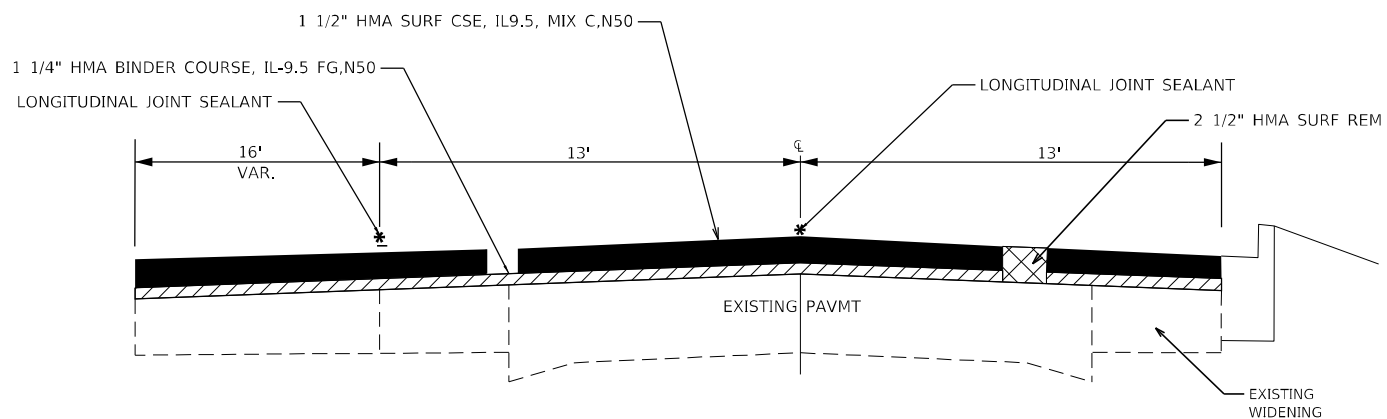

**TYPICAL SECTION 5**  
 STA 25+77 TO STA 22+82

**NOTE: REMOVE EXISTING HMA DOWN TO BARE CONCRETE  
 (FROM HICKORY ST TO CHESTNUT ST)**

\* FAS 323 / FAP 71  
 \*\* (112&112Z)&(38-5HB-4)RS-3,SW

MODEL: Default  
 FILE: M:\B1015\p101100502\work\1101100502\1101100502.dwg P:\projects\1101100502\1101100502\1101100502.dwg

USER NAME = pletschtr	DESIGNED - _____	REVISED - _____
DRAWN - _____	REVISION - _____	REVISION - _____
PLOT SCALE = 100,0421' / in.	CHECKED - _____	REVISION - _____
PLOT DATE = 12/15/2021	DATE - _____	REVISION - _____

**STATE OF ILLINOIS  
 DEPARTMENT OF TRANSPORTATION**

**TYPICAL SECTIONS**

SCALE: \_\_\_\_\_ SHEET \_\_\_\_ OF \_\_\_\_ SHEETS STA. \_\_\_\_\_ TO STA. \_\_\_\_\_

F.A.* RTE.	SECTION	COUNTY	TOTAL SHEETS	SHEET NO.
*	**	IROQUOIS	40	9
CONTRACT NO. 66K77				

ILLINOIS FED. AID PROJECT



MAINLINE SCHEDULE

STA. TO STA.	LEN	WID	SHLD WIDTH	PRKG VAR DEPTH SURF REM	PRKG HMA SURF CSE	RR BINDER CSE IL-9.5FG, N50 1"	HMA SURF REM 3 3/4"	HMA SURF REM 2 1/2"	HMA SURF REM DECK 1 1/2"	HMA SURF CSE, IL-9.5, MIX C N50 1 1/2"	BINDER CSE IL-9.5FG, N50 1 1/4"	BINDER CSE IL-19.0 N50 2 1/4"	BINDER COURSE (HM)	MIX JTS, CRACKS & FLGWYS	LJS	BIT. MAT'L (TACK COAT)	AGG WEDGE SHLD TY B	TEMP RAMP	
	FT	FT	FT	SQ YD	TONS	TONS	SQ YD	SQ YD	SQ YD	TONS	TONS	TONS	TONS	TONS	FOOT	POUND	TONS	SQ YD	
FAP RURAL																			
10+87.	15+00.	413	24	20						2019				0.3	413	1363	31.4	36.0	
15+00.	18+77.	377	28	20						2011				0.4	211	1357			
18+77.	21+09.	232	37.5	20						1482				0.3		1001			
21+09.	21+82.	73	46	20						535				0.1		361			
21+82.	23+38.	156	28	20						832				0.1		562			
23+38.	24+30.	92	46	20						675				0.1		455			
24+30.	26+36.	206	40	20						1373				0.3		927			
26+36.	28+27.	191	34	20						1146				0.2		774			
28+27.	28+89.	62	28	20						331				0.1		223			
28+89.	30+00.	111	28	10					469	39		44	0.2	0.1		316			
TOTAL FAP RURAL					0	0	0	10404	0	469	913	0	1354	3	2	624	7339	31	36
FAS RURAL																			
30+00.	31+08.	108	28	10					456	38		42	0.2	0.1		308			
31+08.	31+38.	30																	
31+38.	31+62.	24	28	10					101	9		9	0.0			68			
31+62.	33+55.	193	34	15					1051	88		92	0.4	0.2		709			
33+55.	35+66.	211	40	20					1407	118		118	0.5	0.3		950			
35+66.	36+49.	83	46	20					609	51		53	0.2	0.1		411			
36+49.	38+97.	248	28	20					1323	111		97	0.4	0.2		893			
TOTAL FAS RURAL					0	0	0	4490	0	456	415	0	412	2	1	0	3339	0	0
FAS URBAN																			
38+97.	40+79.	182	28	20					971	82		71	0.3	0.2		655			
40+79.	42+69.	190	28	20					1013	85		74	0.3	0.2	182	684	14.4		
42+69.	48+44.98	575.98	26	8					2176	183		210	0.8	0.5	576	1469	43.7		
STA 48+44.98BK TO 42+92.89AH																			
42+93	36+49.	644	26						1860	156		234	0.9	0.6	644	1256	48.9		
36+49.	34+05.	244	26						705	59		89	0.4	0.2	244	476			
34+05.	25+77.	828	26						2392	201		301	1.2	0.7	828	1615			
25+77.	22+82.	295	26	16	524	62		852		116	60		0.4	0.3	885	575			
22+82.	20+56.	226	28	14	352	41		703		89	49		0.4	0.2	678	475			
20+56.	17+50.	306	24	14	476	56		816		109	57		0.4	0.2	918	551			
17+50.	9+62.	788	24	14	1226	144		2101		279	147		1.1	0.6	2364	1418			
9+62.	1+71.8	790	24	14	1229	145		2107		280	148		1.1	0.6	2371	1422			
1+71.8	+65.	107	24				16	285		24			0.1	0.1	320	192		108.0	
TOTAL URBAN					3807	448	16	9117	6865	0	1662	461	980	7	4	10010	10788	107	108
TOTALS					3807	448	16	24011	6865	925	2991	461	2747	12	7	10634	21465	138	144

NOTE: STATIONS ARE INCREASING TO THE EAST PRIOR TO THE STATION EQUATION AND THEN DECREASING TO THE EAST. THERE IS DUPLICATE STATIONING ON THIS PROJECT.

MODEL: Default  
FILE: \\nafile: public\paw\_bentley.com\paw\DOT\Documents\DOT Office\Drawings\3\Project\3166677\CD\Drawings\3166677-2-18-2021.dwg

\* FAS 323 / FAP 71  
\*\* (112&112Z)&(38-5HB-4)RS-3,5W

USER NAME = pletschr	DESIGNED - _____	REVISED - _____
DRAWN - _____	REVISIONS - _____	
PLOT SCALE = 100,0000' / in.	CHECKED - _____	REVISED - _____
PLOT DATE = 12/15/2021	DATE - _____	REVISED - _____

STATE OF ILLINOIS  
DEPARTMENT OF TRANSPORTATION

SCALE: _____		SHEET _____	OF _____	SHEETS	STA. _____	TO STA. _____
--------------	--	-------------	----------	--------	------------	---------------

F.A. RTE.	SECTION	COUNTY	TOTAL SHEETS	SHEET NO.
**	**	IROQUOIS	40	10
CONTRACT NO. 66K77				
ILLINOIS FED. AID PROJECT				

**SIDEWALK SCHEDULE FOR NEW RAMP INSTALLATION**

LOCATION SIDE STREET	QUAD	SIDEWALK REMOVAL	PCC SIDEWALK 4"	CCC&G REMOVAL	CC&G B6-24	PAVT REM	HMA WIDENING	EARTH EX *	SODDING *	NITROGEN FERTILIZER NUTRIENT *	PHOSPHORUS FERTILIZER NUTRIENT *	POTASSIUM FERTILIZER NUTRIENT *	DETECTABLE WARNINGS
		SQ FT	SQ FT	FOOT	FOOT	SQ FT	SQ YD	CU YD	SQ YD	POUNDS	POUNDS	POUNDS	SQ FT
STATE HICKORY ST	SW	43.8	71.8	11	21.5		6	1.9					8
ELM ST	NW		104	15.5	15.5								8
	SW		113	18	18								8
	NE		76.1	15.5	15.5								8
	SE		123.5	16	16								8
ASH ST	NW	231.3	301.1	41	42.5	55.6			1.7	0.03	0.03	0.03	16
	SW	187.6	241.7	29.5	30.5	8.4							16
	NE	96.4	122.7	19	19								10
	SE	147.9	199.6	17	17								8
MAPLE ST	NW	114.3	136.1	13.5	13.5								8
	SW	137.2	156.7	9.5	9.5								8
	NE	151.2	170.8	22.5	22.5								16
	SE	191.5	238	44	48	92.3			6.1	0.11	0.11	0.11	20
EVERGREEN ST	NW	239.6	321.8	24	24								16
	SW	116.6	116.3	11	11								16
	NE	230.9	267.5	9	9								10
	SE	93.7	116.2	18	18								8
WALNUT ST	NW	225.8	242.8	8	16				9.8	0.18	0.18	0.18	8
	SW	138.5	155.5	24	24								8
	NE	225.7	293.5	18.5	18.5								20
	SE	238.2	2.8.2	34	34								16
CHESTNUT ST	NW	220.4	306.8	39	43.6	133.5							20
	NE	66.4	169.9		28	150.5							10
<b>SUBTOTAL</b>		<b>3097</b>	<b>4045</b>	<b>458</b>	<b>515</b>	<b>440</b>	<b>6</b>	<b>2</b>	<b>18</b>	<b>0.33</b>	<b>0.33</b>	<b>0.33</b>	<b>274</b>
CITY													
ELM ST	NW	68.2											
	SW	78.5											
	NE	53.6											
	SE	85.5											
<b>SUBTOTAL</b>		<b>286</b>	<b>0</b>	<b>0</b>	<b>0</b>	<b>0</b>	<b>0</b>	<b>0</b>	<b>0</b>	<b>0.00</b>	<b>0.00</b>	<b>0.00</b>	<b>0</b>
<b>TOTAL</b>		<b>3383</b>	<b>4045</b>	<b>458</b>	<b>515</b>	<b>440</b>	<b>6</b>	<b>2</b>	<b>18</b>	<b>0.33</b>	<b>0.33</b>	<b>0.33</b>	<b>274</b>

\* THESE ITEMS SHALL BE INCLUDED IN THE COST OF THE SIDEWALK PAY ITEMS, AS OUTLINED IN THE SPECIAL PROVISIONS UNDER "PREPARATION AND RESTORATION OF SIDEWALK WORK AREAS".

MODEL: Default  
FILE: \\malfp-pw\project-pw\benefit\com\PI\DOT\Documents\DOT\Office\Dir\dir: 3\Project\0366677\CADD\data\CAD\Sheet\0366677-2-18-2021.dgn

\* FAS 323 / FAP 71  
\*\* (112&112Z)&(38-5HB-4)RS-3,5W

USER NAME = pletschr	DESIGNED - _____	REVISED - _____
	DRAWN - _____	REVISED - _____
PLOT SCALE = 100,0000' / in.	CHECKED - _____	REVISED - _____
PLOT DATE = 12/15/2021	DATE - _____	REVISED - _____

**STATE OF ILLINOIS  
DEPARTMENT OF TRANSPORTATION**

**SCHEDULES**

SCALE: \_\_\_\_\_ SHEET \_\_\_ OF \_\_\_ SHEETS STA. \_\_\_\_\_ TO STA. \_\_\_\_\_

F.A. RTE.	SECTION	COUNTY	TOTAL SHEETS	SHEET NO.
*	**	IROQUOIS	40	11
			CONTRACT NO. 66K77	
			ILLINOIS FED. AID PROJECT	

**SIDEROADS & ENTRANCES**

STATION	NAME	SIDE	WIDTH FRONT	WIDTH BACK	VARIABLE DEPTH SURF REM	INCIDENTAL HMA SURF MIX "C" N50	HMA SURF REM 3 3/4"	HMA SURF CSE, IL-9.5, MIX C N50 1 1/2"	BINDER CSE IL-19.0 N50 2 1/4"	BIT MATL (TACK COAT)	FURN EX	SEED CL 2A	NITROGEN FERTILIZER NUTRIENT	PHOSPHORUS FERTILIZER NUTRIENT	POTASSIUM FERTILIZER NUTRIENT	EROSION CONTROL BLANKET	TEMP RAMP	
					SQ YD	TON	SQ YD	TONS	TONS	POUND	CU YD	ACRE	POUND	POUND	POUND	SQ YD	SQ YD	
13+87	CE HMA	LT	65	55	66.7	7.5				30.0								
15+27	PE HMA	LT	25	12	20.6	2.3				9.3								
16+24	FE HMA	RT	28	20	26.7	3.0				12.0								
21+51	FRONTAGE RD	LT	65	18	138.3	15.5				62.3	0.6	0.01	0.9	0.9	0.9	48.4	36.0	
21+51	FRONTAGE RD	RT	58	18	126.7	14.2				57.0	0.6	0.01	0.9	0.9	0.9	48.4	32.0	
23+12	RAMP	LT	130	45			291.7	24.5	36.8	196.9	0.6	0.01	0.9	0.9	0.9	48.4	72.0	
23+28	RAMP	RT	100	48			246.7	20.7	31.1	166.5	0.6	0.01	0.9	0.9	0.9	48.4	56.0	
<b>TOTAL FAP RURAL</b>					<b>378.9</b>	<b>42.4</b>	<b>538.4</b>	<b>45.2</b>	<b>67.8</b>	<b>533.9</b>	<b>2.4</b>	<b>0.04</b>	<b>3.6</b>	<b>3.6</b>	<b>3.6</b>	<b>193.6</b>	<b>196.0</b>	
36+70	RAMP	LT	90	44		0.0	223.3	18.8	28.1	150.7	0.6	0.01	0.9	0.9	0.9	48.4	50.0	
36+70	RAMP	RT	136	60		0.0	326.7	27.4	41.2	220.5	0.6	0.01	0.9	0.9	0.9	48.4	76.0	
41+08	CE HMA	RT	47	36	46.1	5.2				20.8								
41+55	CE HMA	RT	47	36	46.1	5.2				20.8								
41+55	CE HMA	LT	42	28	38.9	4.4				17.5								
44+96	PE HMA	RT	40	18	32.2	3.6				14.5								
46+42	CE HMA	LT	46	27	40.6	4.5				18.3								
48+04	CE HMA	LT	45	27	40.0	4.5				18.0								
<b>STATION EQUATION</b>																		
42+00	PE HMA	RT	47	18	36.1	4.0				16.3								
39+12	PE HMA	RT	35	16	28.3	3.2				12.8								
<b>TOTAL FAS RURAL</b>					<b>308.3</b>	<b>34.5</b>	<b>550.0</b>	<b>46.2</b>	<b>69.3</b>	<b>510.0</b>	<b>1.2</b>	<b>0.02</b>	<b>1.8</b>	<b>1.8</b>	<b>1.8</b>	<b>96.8</b>	<b>126.0</b>	
38+46	PE HMA	LT	21	10	17.2	1.9				7.8								
37+30	PE HMA	LT	45	18	35.0	3.9				15.8								
36+33	N PINE ST	LT	71	23	156.7	17.5				70.5							39.0	
34+46	PE AGG	RT																
34+07	PE AGG	LT																
33+05	PE AGG	LI																
31+48	PE AGG	RT																
30+71	PE AGG	LT																
29+70	PE PCC	RT																
29+62	PE AGG	LT																
28+42	PE AGG	RT																
27+82	PE AGG	LT																
27+48	PE AGG	RT																
27+00	PE AGG	RT																
26+95	PE AGG	LT																
25+64	PE AGG	RT																
24+59	PE AGG	RT																
24+06	PE AGG	LT																
23+17	S HICKORY ST	RT	40	18	96.7	10.8				43.5							22.0	
22+29	PE PCC	LT																
20+29	ELM ST	LT	46	18	106.7	11.9				48.0							26.0	
20+29	ELM ST	RT	46	18	106.7	11.9				48.0							26.0	
16+72	ASH ST	LT	42	18	100.0	11.2				45.0							23.0	
16+72	ASH ST	RT	42	18	100.0	11.2				45.0							23.0	
13+24	MAPLE ST	LT	48	18	110.0	12.3				49.5							27.0	
13+24	MAPLE ST	RT	48	18	110.0	12.3				49.5							27.0	
9+69	EVERGREEN ST	LT	62	18	133.3	14.9				60.0							34.0	
9+69	EVERGREEN ST	RT	70	18	146.7	16.4				66.0							39.0	
6+72	WALNUT ST	LT	54	18	120.0	13.4				54.0							30.0	
6+72	WALNUT ST	RT	42	18	100.0	11.2				45.0							23.0	
4+54	ALLEY	LT	32	18	83.3	9.3				37.5							18.0	
2+55	CHESTNUT ST	LT	82	54	226.7	25.4				102.0							46.0	
2+55	CHESTNUT ST	RT	40	25	108.3	12.1				48.8							22.0	
<b>TOTAL FAS URBAN</b>					<b>1857.2</b>	<b>208.0</b>	<b>0.0</b>	<b>0.0</b>	<b>0.0</b>	<b>835.8</b>	<b>0.0</b>	<b>0.0</b>	<b>0.0</b>	<b>0.0</b>	<b>0.0</b>	<b>0.0</b>	<b>0.0</b>	<b>425.0</b>
<b>TOTAL</b>					<b>2544</b>	<b>285</b>	<b>1088</b>	<b>91</b>	<b>137</b>	<b>1880</b>	<b>4</b>	<b>0.1</b>	<b>5</b>	<b>5</b>	<b>5</b>	<b>290</b>	<b>747</b>	

\* FAS 323 / FAP 71  
 \*\* (112&112Z)&(38-5HB-4)RS-3,5W

MODEL: P:\default  
 FILE: M:\MFC\_Plan\Subsect-pw-bee\mfc.com\PIV\DOT\Documents\DOT\_Offices\Dir\mfc\_3\Project\3136677\CD\DATA\CD\PE\sect3136677-38-5hb-4.dgn

USER NAME = pletschr	DESIGNED - _____	REVISED - _____
	DRAWN - _____	REVISED - _____
PLOT SCALE = 100,0000' / in.	CHECKED - _____	REVISED - _____
PLOT DATE = 12/15/2021	DATE - _____	REVISED - _____

**STATE OF ILLINOIS  
 DEPARTMENT OF TRANSPORTATION**

<b>DETAILS</b>	
SCALE: _____	SHEET ____ OF ____ SHEETS STA. _____ TO STA. _____

F.A. RTE. _____	SECTION **	COUNTY IROQUOIS	TOTAL SHEETS 40	SHEET NO. 12
			CONTRACT NO. 66K77	
ILLINOIS FED. AID PROJECT				

**THERMOPLASTIC PAVEMENT MARKING SCHEDULE**

STA. TO STA.	LENGTH	THERMOPLASTIC									GROOVING FOR RECESSED PAVEMENT MARKING						
		4" EOP	4" NO-PASS	6" X-WALK	6" SKIPS	8" (MM)	12"	12"	24" STOP RR X-ING	LETTERS & SYMBOLS	5"	7"	9"	13"	25"	LETTERS & SYMBOLS	
		WHITE	YELLOW	WHITE	YELLOW	WHITE	WHITE	YELLOW	WHITE	SQ FT	FOOT	FOOT	FOOT	FOOT	FOOT	SQ FT	
<b>FAP RURAL</b>																	
10+87.	15+87.	500															
15+87	23+66.	779	1447	1925.0			144.0	90.5	26.0	44.0	31.2	3372		144	26	44	31.2
23+66.	30+00.	634	1274	1175.0			243.5				58.3	2449		244			58.3
<b>TOTAL FAP RURAL</b>			<b>2721.0</b>	<b>3100.0</b>			<b>387.5</b>	<b>90.5</b>	<b>26.0</b>	<b>44.0</b>	<b>89.5</b>	<b>5821.0</b>		<b>387.5</b>	<b>26.0</b>	<b>44.0</b>	<b>89.5</b>
<b>FAS RURAL</b>																	
30+00	38+97.	897	1621	1644.0			407.5	105.0		44.0	89.5	3265		408		44	89.5
<b>TOTAL FAS RURAL</b>			<b>1621.0</b>	<b>1644.0</b>			<b>407.5</b>	<b>105.0</b>		<b>44.0</b>	<b>89.5</b>	<b>3265.0</b>		<b>407.5</b>		<b>44.0</b>	<b>89.5</b>
<b>URBAN</b>																	
38+97	42+29.	332	648	1114.0					32.0			1762				32	
42+29.	48+44.98	616															
STA 48+44.98 BK = 42+92.89 AH																	
42+92.89	20+17.	2276															
20+17.	6+72	1345	4328		105.0	960.0		110.0				4328	1065				
6+72.	+65	607	542	810.0			120.0	136.0		72.0	122.4	1352	120			72	122.4
<b>TOTAL URBAN</b>			<b>5518.0</b>	<b>1924.0</b>	<b>105.0</b>	<b>1080.0</b>		<b>246.0</b>	<b>32.0</b>	<b>72.0</b>	<b>122.4</b>	<b>7442.0</b>	<b>1185.0</b>	<b>0.0</b>	<b>32.0</b>	<b>72.0</b>	<b>122.4</b>
<b>TOTAL</b>		<b>7986</b>	<b>16528</b>		<b>1185</b>		<b>795</b>	<b>500</b>		<b>160</b>	<b>301</b>	<b>16528</b>	<b>1185</b>	<b>795</b>	<b>58</b>	<b>160</b>	<b>301</b>

\*NOTE: ALL THERMOPLASTIC PAVEMENT MARKINGS TO BE GROOVED WITH THE EXCEPTION OF THE 12" WHITE LINES.

**PAINT PAVEMENT MARKING SCHEDULE**

STA. TO STA.	LENGTH	2 APPLICATIONS OF PAINT			SHORT-TERM PAVEMENT MARKING	SHORT-TERM PAVEMENT MARKING REMOVAL	RAISED REFLECTIVE PAVEMENT MARKERS	RAISED REFLECTIVE PAVEMENT MARKERS REMOVAL	
		PAINT 4" EOP	PAINT 4" NO PASS	PAINT 6" SKIPS					
		WHITE	YELLOW	YELLOW					
<b>FAP RURAL</b>									
10+87.	15+87.	500	2000	1330	160.0	150	17	6.3	6.3
15+87	23+66.	779							
23+66.	30+00.	634							
<b>TOTAL FAP RURAL</b>			<b>2000.0</b>	<b>1330.0</b>	<b>160.0</b>	<b>150.0</b>	<b>16.7</b>	<b>6.3</b>	<b>6.3</b>
<b>FAS RURAL</b>									
30+00	38+97.	897				269	30	11.2	11.2
<b>TOTAL FAS RURAL</b>						<b>269.1</b>	<b>29.9</b>	<b>11.2</b>	<b>11.2</b>
<b>URBAN</b>									
38+97	42+29.	332				100	37	4.2	4.2
42+29.	48+44.98	616	2464	1500	1080.0	185	68	7.7	7.7
STA 48+44.98 BK = 42+92.89 AH									
42+92.89	20+17.	2276	8972			683	253	28.4	28.4
20+17.	6+72	1345				404	149	16.8	16.8
6+72.	+65	607				182	67	7.6	7.6
<b>TOTAL URBAN</b>			<b>11436.0</b>	<b>1500.0</b>	<b>1080.0</b>	<b>1552.8</b>	<b>575.1</b>	<b>64.7</b>	<b>64.7</b>
<b>TOTAL</b>		<b>7986</b>	<b>16266</b>		<b>1240</b>	<b>1972</b>	<b>622</b>	<b>82</b>	<b>82</b>

\* FAS 323 / FAP 71  
\*\* (112&1127)&(38-5HB-4)RS-3,SW

MODEL: Default  
FILE: \\mari... \public\paw.bendley.com\PIV\DOT\Documents\DOT Office\Dir\Dir: 3\Project\1036667\1\CD\DATA\CAD\Preest\1036667-2-18-2021.dgn

USER NAME = pletschr	DESIGNED - _____	REVISED - _____
	DRAWN - _____	REVISED - _____
PLOT SCALE = 100,0000' / in.	CHECKED - _____	REVISED - _____
PLOT DATE = 12/15/2021	DATE - _____	REVISED - _____

**STATE OF ILLINOIS  
DEPARTMENT OF TRANSPORTATION**

**DETAILS**

SCALE: \_\_\_\_\_ SHEET \_\_\_\_ OF \_\_\_\_ SHEETS STA. \_\_\_\_\_ TO STA. \_\_\_\_\_

F.A. RTE.	SECTION	COUNTY	TOTAL SHEETS	SHEET NO.
*	**	IROQUOIS	40	13
CONTRACT NO. 66L77				
ILLINOIS FED. AID PROJECT				

DRAINAGE SCHEDULE											
LOCATION	SIDE	LENGTH	WIDTH	DEPTH	ABANDON EXISTING CULVERT	GRADING AND SHAPING DITCHES	SEEDING CL 2A	NITRO FERT NUT	PHOSP FERT NUT	POT FERT NUT	EROSION CONTROL BLANKET
STA. TO STA.	S/N	FOOT	FOOT	FOOT	EACH	FOOT	ACRE	LB	LB	LB	SQ YD
RURAL QUANTITIES											
14+88.00	16+08.00	S	120.0	12	0.5	120.0	0.033	2.975	2.975	2.975	160.00
37+88.00	39+88.00	S	200.0	12	0.5	200.0	0.055	4.959	4.959	4.959	266.67
37+88.00	38+38.00	N	50.0	12	0.5	50.0	0.014	1.240	1.240	1.240	66.67
42+28.00	43+78.00	S	150.0	12	0.5	150.0	0.041	3.719	3.719	3.719	200.00
FAP RURAL						0.0	520.0	0.1	12.9	12.9	693.3
37+41.00	37+76.00	* N	35.0	12	0.33	1.00	35.0	0.010	0.868	0.868	46.67
FAS RURAL						1.0	35.0	0.0	0.9	0.9	46.7
					<b>TOTALS</b>	<b>1</b>	<b>555</b>	<b>0.15</b>	<b>14</b>	<b>14</b>	<b>740</b>

ADJUSTMENT SCHEDULE		
LOCATION	FRAMES & LIDS TO BE ADJ	WATER VALVE TO BE ADJ
	EACH	EACH
<i>IL 54</i>		
ELM ST TO ASH ST	2	0
ASH ST TO MAPLE ST	1	0
MAPLE ST TO EVERGREEN ST	2	0
EVERGREEN ST TO WALNUT ST	1	1
WALNUT ST TO CHESTNUT ST	3	0
<b>TOTALS</b>	<b>9</b>	<b>1</b>

\* RESIDENT TO VERIFY LOCATIONS ON SITE

\* 37+41 TO 37+76 IS ON THE EAST SIDE OF THE STATION EQUATION NEAR PINE STREET.  
 \* THIS AREA SHALL BE GRADED TO FLOW TO THE WEST.

ILL RTE 54		LOCATION: 0.4 MI W OF I-57 TO US 45 IN ONARGA				IROQUOIS COUNTY	
MONUMENT NUMBER	DESCRIPTION	APPROXIMATE LOCATION	EXISTING MONUMENT TYPE	PROPOSED MONUMENT TYPE	MONUMENT RECORD TO BE RECORDED	RESPONSIBILITY	
A054801	CENTER OF SECTION 24, T26N, R10E, 3RD PM	W SEMINARY ST INTERSECTION	PK NAIL	TYPE 1	YES	1	
054803	CENTER OF INTERSECTION	W SEMINARY ST AND EVERGREEN ST	COTTON GIN SPIKE	SURVEY NAIL	NO	2	

ONLY THE ORIGINAL SCOPE OF THIS JOB HAS BEEN SEARCHED FOR MONUMENTS. R.E. MUST INFORM PLATS AND PLANS TO SEARCH FOR ADDITIONAL MONUMENTS PRIOR TO MILLING IF ADDENDUMS HAVE BEEN ADDED TO THIS JOB.  
 UNKNOWN MONUMENTS SET BY OTHERS MAY EXIST. IF AN UNLISTED MONUMENT IS FOUND, R.E. IS REQUIRED TO PROTECT THE MONUMENT FROM DAMAGE UNTIL A PLATS AND PLANS LAND SURVEYOR CAN DOCUMENT THE MONUMENT. PLATS AND PLANS WILL RESET SUCH MONUMENTS IN KIND FOLLOWING CONSTRUCTION.  
 UPON PAVING COMPLETION, R.E. WILL DIRECT PLATS AND PLANS TO STAKE FOR TYPE 1 CORING AND SET THE OTHER LISTED MONUMENT.  
 NOTE: FOR BIDDING PURPOSES NO CONTRACTED LAND SURVEYING SERVICES WILL BE REQUIRED.  
 PLATS AND PLANS WILL PREPARE THE REQUIRED MONUMENT RECORD.

RESPONSIBILITY:  
 1) RESIDENT TO RE-ESTABLISH MONUMENT (PAY ITEM REQUIRED. PERMANENT SURVEY MARKER, TYPE 1)  
 2) PLATS AND PLANS TO RE-ESTABLISH MONUMENT

MODEL: Default  
 FILE: \\nafile.pva\uldest-pw-beadefy.com\FW\DOT\Documents\DOT Office\Dir\rdt\_3\Project\110366677\CADD\data\CAD\Faces\110366677-rh-schedule.dgn

\* FAS 323 / FAP 71  
 \*\* (112&1127)6(38-5HB-4)RS-3,SW

USER NAME = pletschr	DESIGNED - _____	REVISED - _____	<b>STATE OF ILLINOIS DEPARTMENT OF TRANSPORTATION</b>	<b>SUMMARY OF QUANTITIES</b>			F.A. RTE.	SECTION	COUNTY	TOTAL SHEETS	SHEET NO.
DRAWN - _____	REVISIONS - _____	*					**	IROQUOIS	40	14	
PLOT SCALE = 100,0000' / in.	CHECKED - _____	REVISIONS - _____		SCALE: _____ SHEET ___ OF ___ SHEETS STA. _____ TO STA. _____			CONTRACT NO. 66K77		ILLINOIS FED. AID PROJECT		
PLOT DATE = 12/15/2021	DATE - _____	REVISIONS - _____									

MODEL: Default  
 FILE NAME: p:\project-caw-beadley.com\PI\DOT\Documents\DOT Office\Dir\dir: 3\Project\036667\CAD\data\CAD\Sheet\036667-rtr-detail.dgn

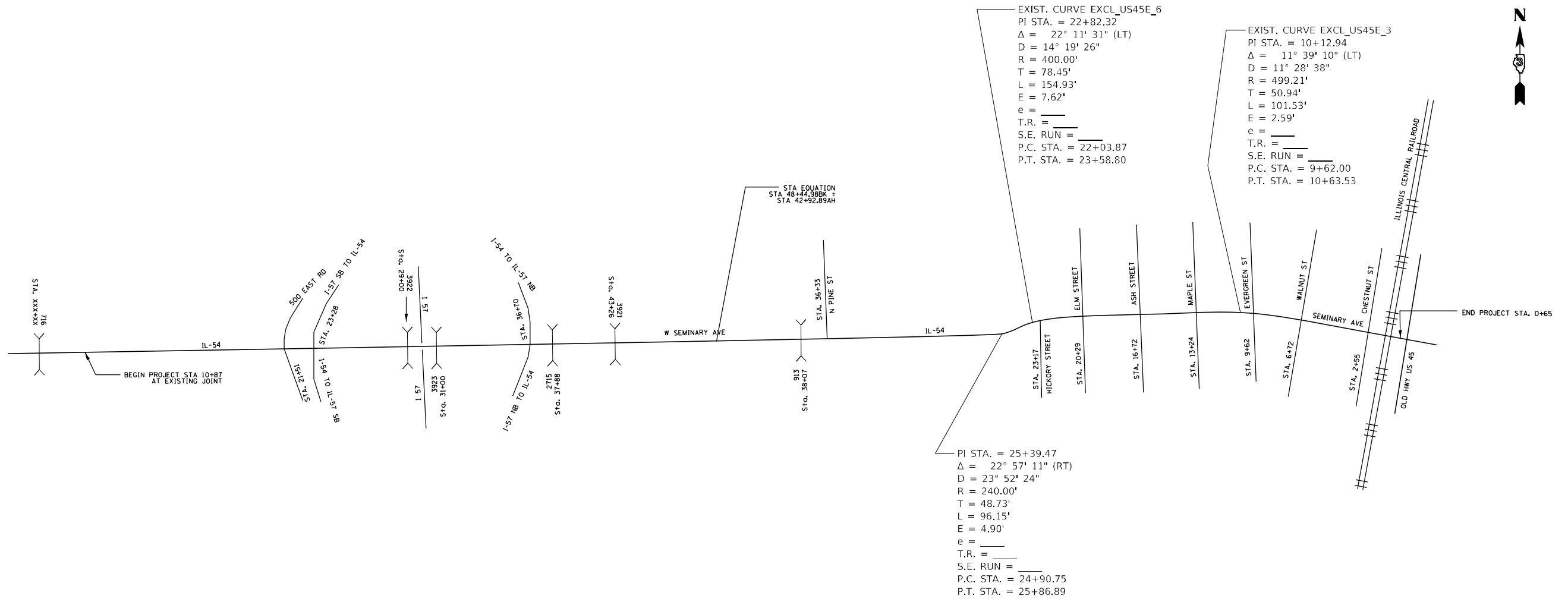

\* FAS 323 / FAP 71  
 \*\* (112&112Z)&(38-5HB-4)RS-3,SW

USER NAME = pletschr	DESIGNED - _____	REVISED - _____
DRAWN - _____	REVISOR - _____	REVISION - _____
PLOT SCALE = 100,0000' / in.	CHECKED - _____	REVISOR - _____
PLOT DATE = 12/15/2021	DATE - _____	REVISION - _____

**STATE OF ILLINOIS  
 DEPARTMENT OF TRANSPORTATION**

**PROJECT LAYOUT**

SCALE: \_\_\_\_\_ SHEET \_\_\_\_ OF \_\_\_\_ SHEETS STA. \_\_\_\_\_ TO STA. \_\_\_\_\_

F.A.* RTE.	SECTION	COUNTY	TOTAL SHEETS	SHEET NO.
*	**	IROQUOIS	40	15
CONTRACT NO. 66K77				
ILLINOIS FED. AID PROJECT				



SIDEWALK REM = 43.8 SQ FT

CURB REM = 11.0 FT

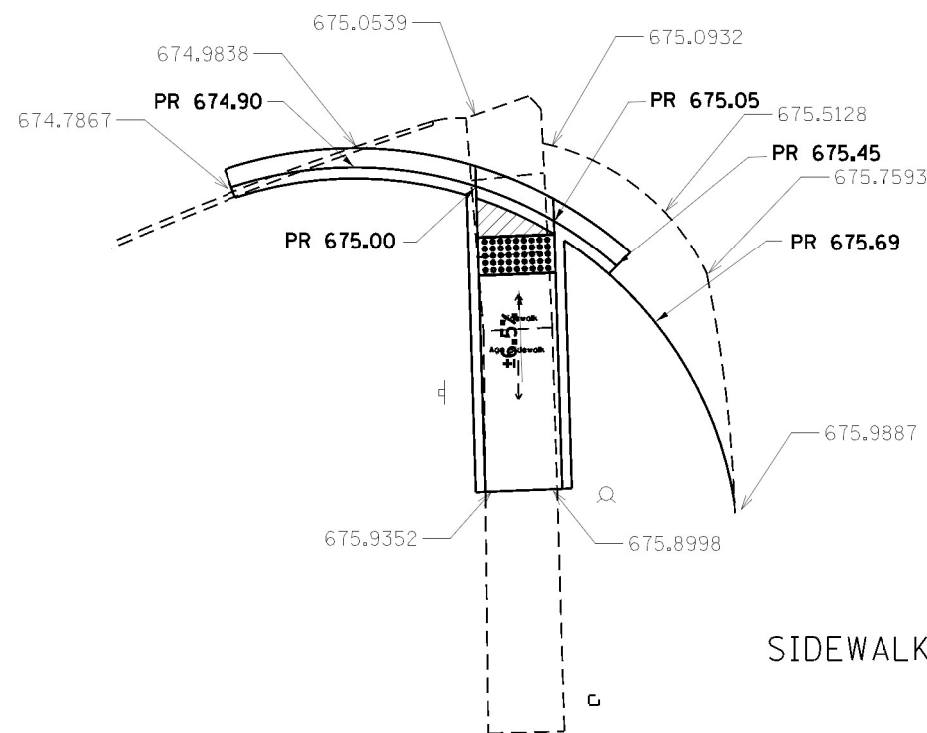

SIDEWALK 4" = 71.8 SQ FT

CCC & G = 21.5 FT

DETECTABLE WARNING = 8.0 SQ FT

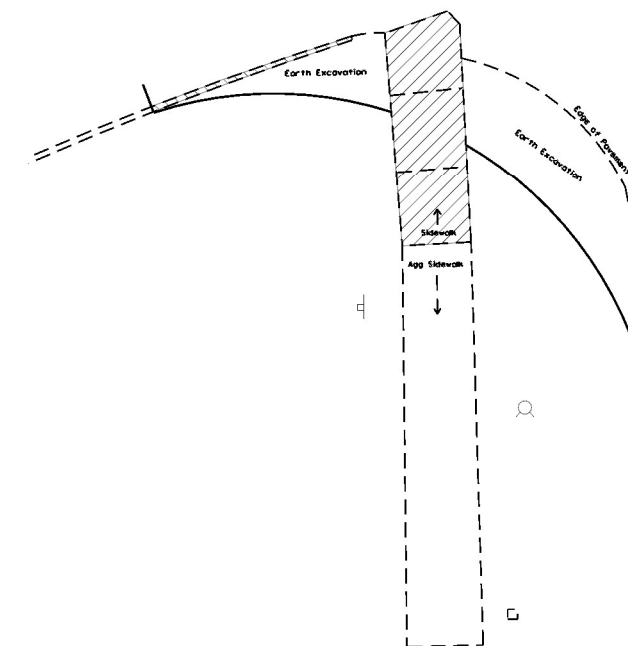

- CURB AND GUTTER REMOVAL
- SIDEWALK REMOVAL
- PAVEMENT REMOVAL
- DETECTABLE WARNING
- TURNING SPACE / LEVEL LANDING  
15% CROSS-SLOPE BOTH DIRECTION
- SODDING AREA INCLUDED IN SW WORK



SCALE IN FEET

NOTES:

1. SEE HIGHWAY STANDARDS 424001 - 424031 FOR MAX SLOPES AND ADDITIONAL REQUIREMENTS.
2. SEE HIGHWAY STANDARD 606001 FOR CURB AND GUTTER REQUIREMENTS NEXT TO ADA RAMPS.
3. ALL CROSS-SLOPES IN THE DIRECTION OF TRAVEL ARE AN ABSOLUTE MAXIMUM OF 2% LAYOUT SHOULD BE AT 1.5% TO ALLOW FOR ERROR WHILE REMAINING WITH THE MAXIMUM SLOPE.
4. SIDEWALK CURBS ARE SHOW ONLY AS REQUIRED BY FIELD CONDITIONS AND MAY BE OMITTED IF FOUND TO BE UNNECESSARY.
5. PEDESTRIAN PUSH BUTTON SIGN PAY ITEM TO BE INCIDENTAL TO THE PDESTRIAN PUSH BUTTON PAY ITEM.

MODEL: Default  
 FILE: Model - p:\mddot\paw\berkeley.com\PROJECTS\66K77\CADD\DWG\CADD\Sheet\0366K77 Prop ADA Plans.dgn

USER NAME = pletschr	DESIGNED -	REVISED -
PLOT SCALE = 10.0000' / 1"	DRAWN -	REVISED -
PLOT DATE = 12/15/2021	CHECKED -	REVISED -
	DATE -	REVISED -

**STATE OF ILLINOIS  
DEPARTMENT OF TRANSPORTATION**

**ADA DETAILS  
HICKORY STREET SW QUADRANT**

SCALE: SHEET OF SHEETS STA. TO STA.

\* (112 & 112Z) & (38-5HB-4)RS-3.5W

F.A.P. RTE.	SECTION	COUNTY	TOTAL SHEETS	SHEET NO.
71	*	IROQUOIS	40	16
CONTRACT NO. 66K77				
ILLINOIS FED. AID PROJECT				



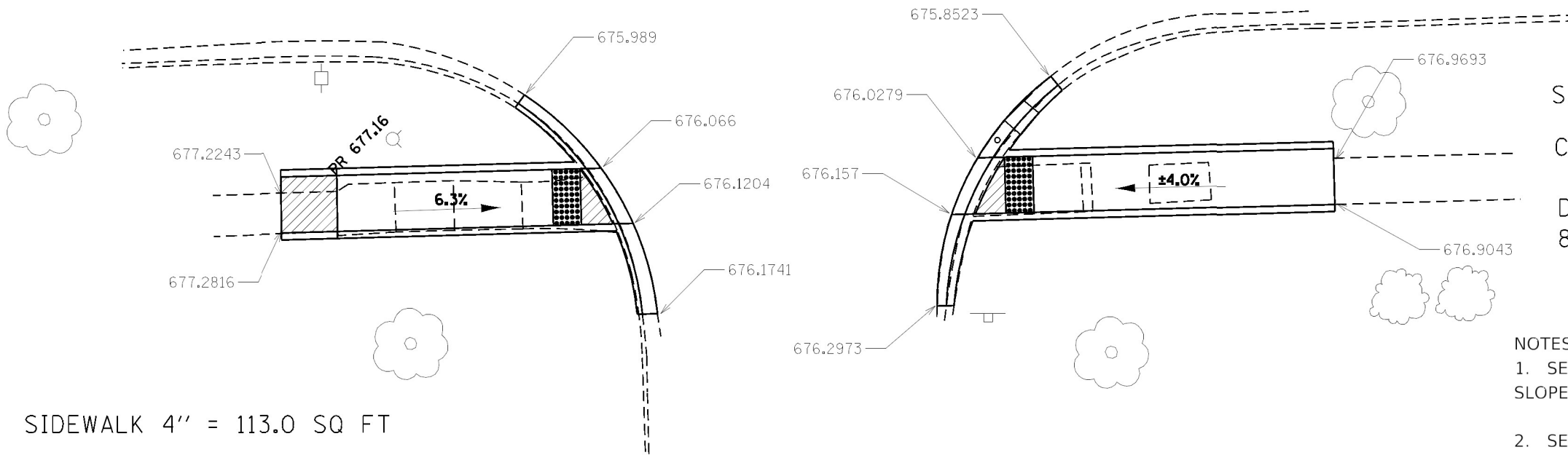







SIDEWALK 4" = 123.5 SQ FT  
 CCC & G = 16.0 FT  
 DETECTABLE WARNING = 8.0 SQ FT



SIDEWALK 4" = 113.0 SQ FT  
 CCC & G = 18.0 FT  
 DETECTABLE WARNING = 8.0 SQ FT

-  CURB AND GUTTER REMOVAL
-  SIDEWALK REMOVAL
-  PAVEMENT REMOVAL
-  DETECTABLE WARNING
-  TURNING SPACE / LEVEL LANDING  
15% CROSS-SLOPE BOTH DIRECTION
-  SODDING AREA INCLUDED IN SW WORK

- NOTES:
- SEE HIGHWAY STANDARDS 424001 - 424031 FOR MAX SLOPES AND ADDITIONAL REQUIREMENTS.
  - SEE HIGHWAY STANDARD 606001 FOR CURB AND GUTTER REQUIREMENTS NEXT TO ADA RAMPS.
  - ALL CROSS-SLOPES IN THE DIRECTION OF TRAVEL ARE AN ABSOLUTE MAXIMUM OF 2% LAYOUT SHOULD BE AT 1.5% TO ALLOW FOR ERROR WHILE REMAINING WITH THE MAXIMUM SLOPE.
  - SIDEWALK CURBS ARE SHOW ONLY AS REQUIRED BY FIELD CONDITIONS AND MAY BE OMITTED IF FOUND TO BE UNNECESSARY.
  - PEDESTRIAN PUSH BUTTON SIGN PAY ITEM TO BE INCIDENTAL TO THE PDESTRIAN PUSH BUTTON PAY ITEM.

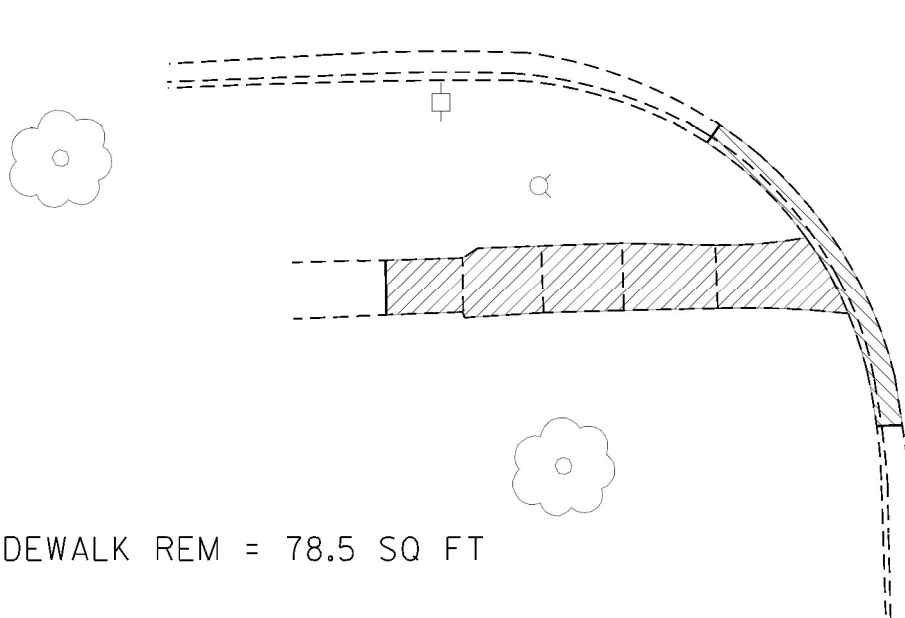

SIDEWALK REM = 78.5 SQ FT  
 CURB REM = 18.0 FT

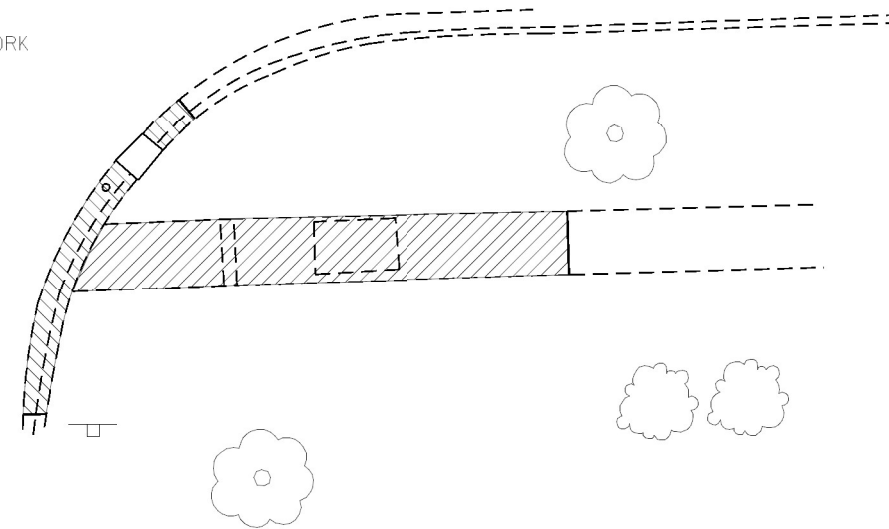

SIDEWALK REM = 85.5 SQ FT  
 CURB REM = 16.0 FT

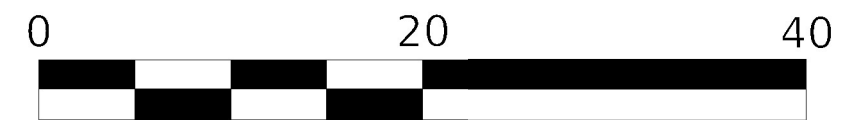

SCALE IN FEET

MODEL: Default  
 FILE: Model - p:\miller\paw\_bentley.com\PROJECTS\Documents\DOT\_Civil\sw\Detail\_3\Project\366K77\CADD\sw\ADA\_Sheets\366K77\_Proj\_ADA\_Plan.dgn

USER NAME = plitschr	DESIGNED -	REVISED -
	DRAWN -	REVISED -
PLOT SCALE = 10.0000" / 1'	CHECKED -	REVISED -
PLOT DATE = 12/15/2021	DATE -	REVISED -

STATE OF ILLINOIS  
 DEPARTMENT OF TRANSPORTATION

ADA DETAILS			
ELM STREET SW & SE QUADRANTS			
SCALE:	SHEET	OF SHEETS	STA. TO STA.

\* (112 & 112Z) & (38-5HB-4)RS-3.5W

F.A.P. RTE.	SECTION	COUNTY	TOTAL SHEETS	SHEET NO.
71	*	IROQUOIS	40	17
CONTRACT NO. 66K77				
ILLINOIS FED. AID PROJECT				

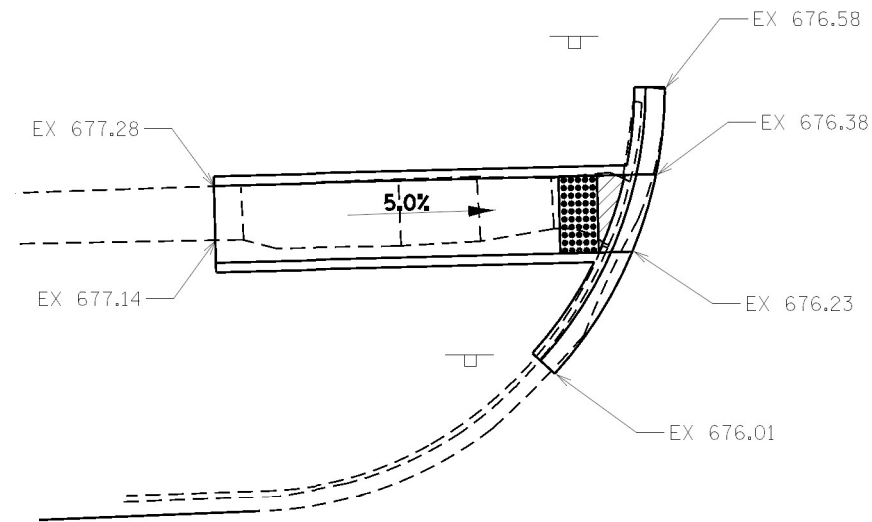

SIDEWALK 4" = 104.0 SQ FT





CCC & G = 15.5 FT

DETECTABLE WARNING = 8.0 SQ FT

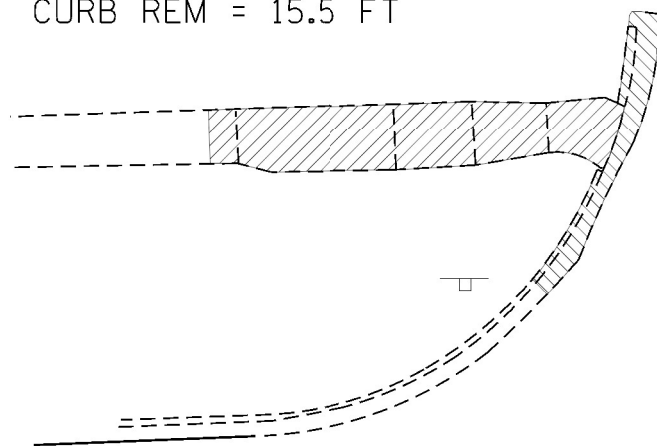
SIDEWALK REM = 68.2 SQ FT

CURB REM = 15.5 FT



-  CURB AND GUTTER REMOVAL
-  SIDEWALK REMOVAL
-  PAVEMENT REMOVAL
-  DETECTABLE WARNING
-  TURNING SPACE / LEVEL LANDING  
15% CROSS-SLOPE BOTH DIRECTION
-  SODDING AREA INCLUDED IN SW WORK

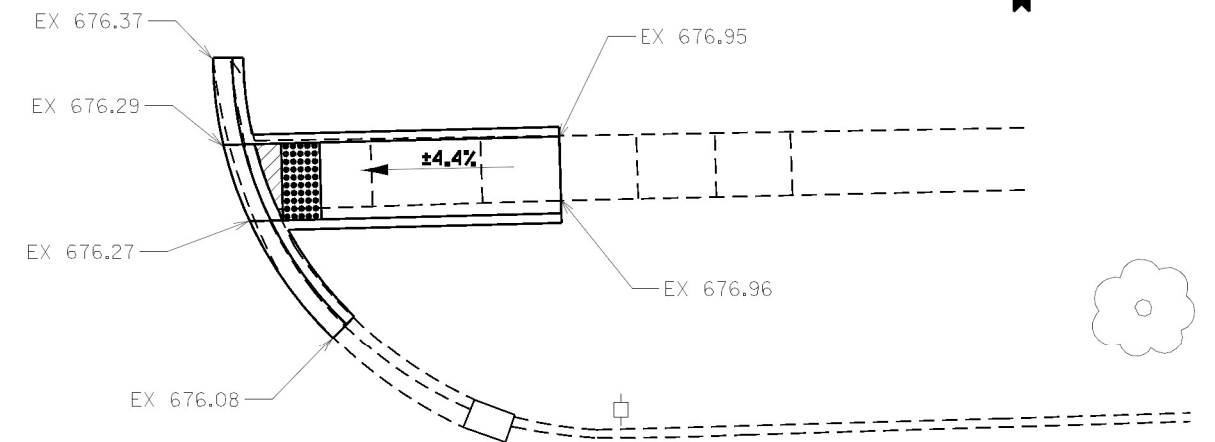

SIDEWALK 4" = 76.1 SQ FT

CCC & G = 15.5 FT

DETECTABLE WARNING = 8.0 SQ FT

SIDEWALK REM = 53.6 SQ FT

CURB REM = 15.5 FT

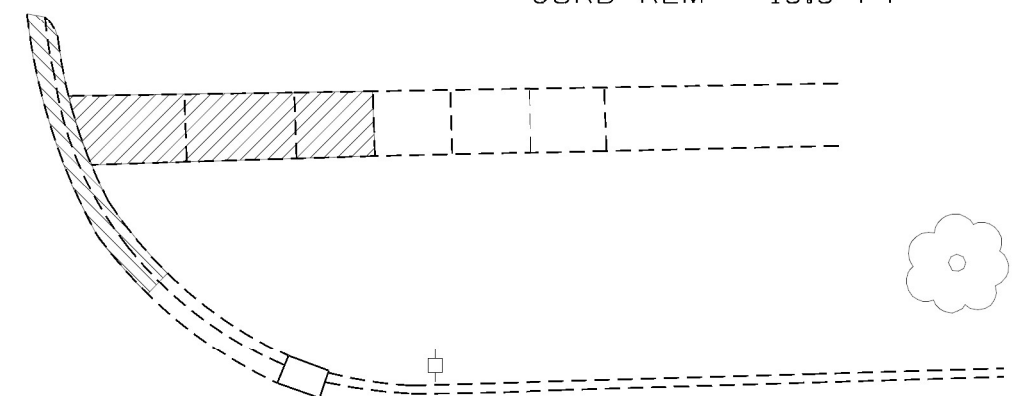

NOTES:

1. SEE HIGHWAY STANDARDS 424001 - 424031 FOR MAX SLOPES AND ADDITIONAL REQUIREMENTS.
2. SEE HIGHWAY STANDARD 606001 FOR CURB AND GUTTER REQUIREMENTS NEXT TO ADA RAMP.
3. ALL CROSS-SLOPES IN THE DIRECTION OF TRAVEL ARE AN ABSOLUTE MAXIMUM OF 2% LAYOUT SHOULD BE AT 1.5% TO ALLOW FOR ERROR WHILE REMAINING WITH THE MAXIMUM SLOPE.
4. SIDEWALK CURBS ARE SHOW ONLY AS REQUIRED BY FIELD CONDITIONS AND MAY BE OMITTED IF FOUND TO BE UNNECESSARY.
5. PEDESTRIAN PUSH BUTTON SIGN PAY ITEM TO BE INCIDENTAL TO THE PDESTRIAN PUSH BUTTON PAY ITEM.

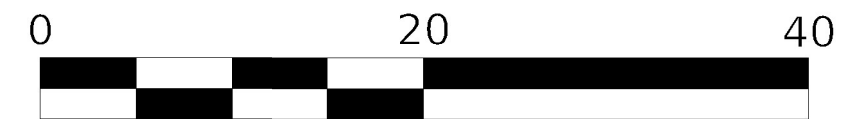

SCALE IN FEET

\*(112 & 112Z) & (38-5HB-4)RS-3.5W

MODEL: Default  
 FILE: \\miller-pw-bentley.com\PWD\DOT\Documents\DOT\_Civil\66K77\CADD\66K77\_Proj\_ADA\_Plan.dgn

USER NAME = pletschr	DESIGNED -	REVISED -
	DRAWN -	REVISED -
PLOT SCALE = 10.0000" / 1'	CHECKED -	REVISED -
PLOT DATE = 12/15/2021	DATE -	REVISED -

**STATE OF ILLINOIS  
DEPARTMENT OF TRANSPORTATION**

**ADA DETAILS  
ELM STREET NW & NE QUADRANTS**

SCALE: SHEET OF SHEETS STA. TO STA.

F.A.P. RTE.	SECTION	COUNTY	TOTAL SHEETS	SHEET NO.
71	*	IROQUOIS	40	18
CONTRACT NO. 66K77				
ILLINOIS FED. AID PROJECT				

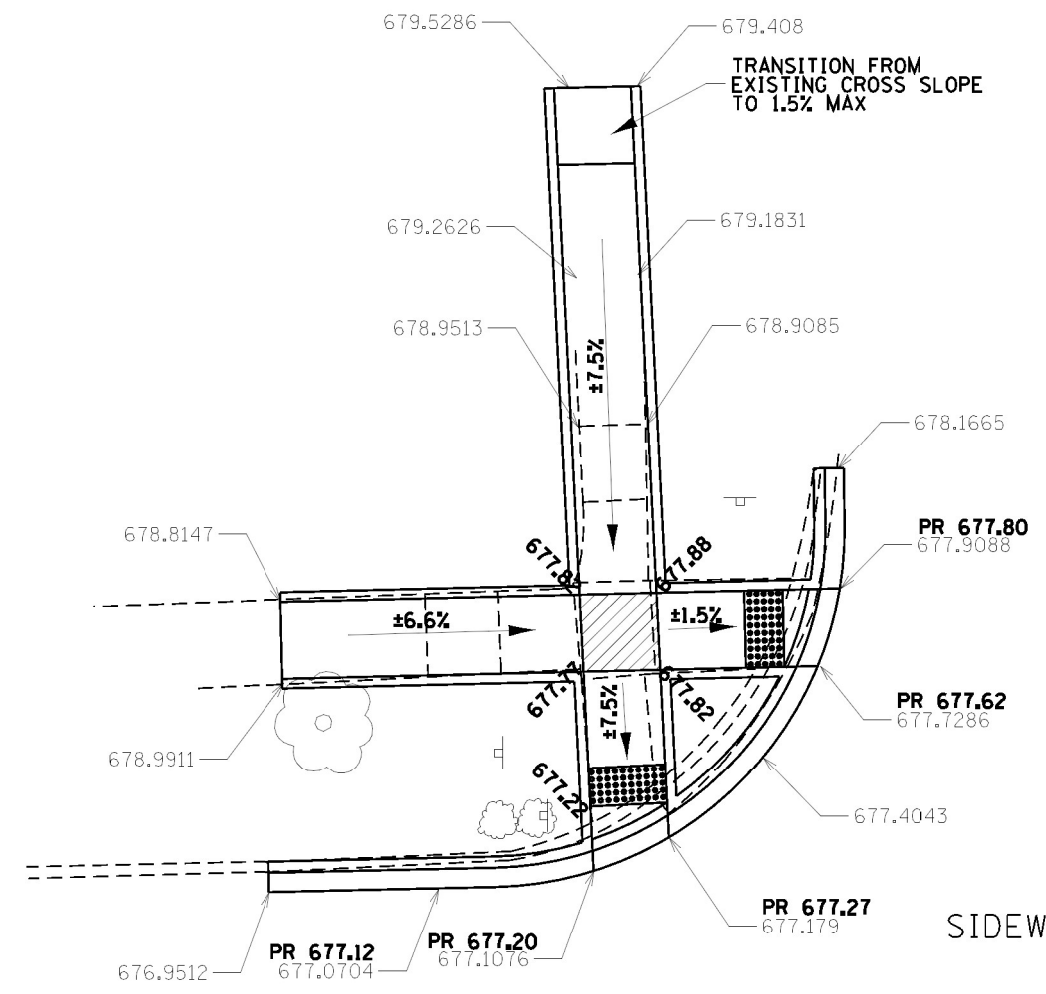

SIDEWALK REM = 231.3 SQ FT

CURB REM = 41.0 FT

PAVEMENT REM = 55.6 SQ FT

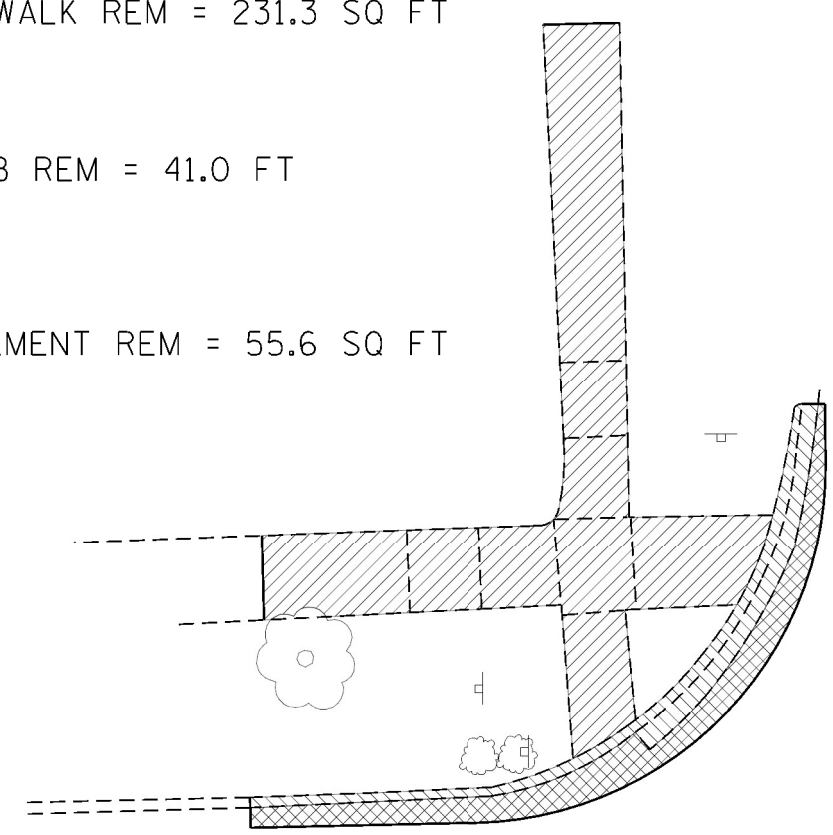

SIDEWALK 4" = 301.1 SQ FT

CCC & G = 42.5 FT

DETECTABLE WARNING =  
8.0 SQ FT + 8.0 SQ FT

SODDING = 1.7 SQ YD

- CURB AND GUTTER REMOVAL
- SIDEWALK REMOVAL
- PAVEMENT REMOVAL
- DETECTABLE WARNING
- TURNING SPACE / LEVEL LANDING  
15% CROSS-SLOPE BOTH DIRECTION
- SODDING AREA  
INCLUDED IN SW WORK

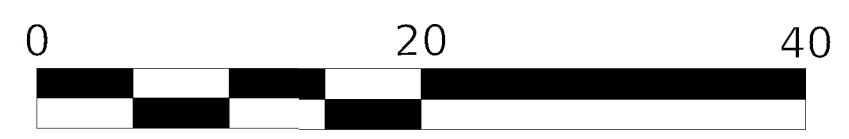

SCALE IN FEET

- NOTES:
1. SEE HIGHWAY STANDARDS 424001 - 424031 FOR MAX SLOPES AND ADDITIONAL REQUIREMENTS.
  2. SEE HIGHWAY STANDARD 606001 FOR CURB AND GUTTER REQUIREMENTS NEXT TO ADA RAMPS.
  3. ALL CROSS-SLOPES IN THE DIRECTION OF TRAVEL ARE AN ABSOLUTE MAXIMUM OF 2% LAYOUT SHOULD BE AT 1.5% TO ALLOW FOR ERROR WHILE REMAINING WITH THE MAXIMUM SLOPE.
  4. SIDEWALK CURBS ARE SHOW ONLY AS REQUIRED BY FIELD CONDITIONS AND MAY BE OMITTED IF FOUND TO BE UNNECESSARY.
  5. PEDESTRIAN PUSH BUTTON SIGN PAY ITEM TO BE INCIDENTAL TO THE PDESTRIAN PUSH BUTTON PAY ITEM.

MODEL: Default  
 FILE: \\miller-planning.com\pwwork\pwwork\pwwork\DOT Office\Director\_3\Projects\0366427\0366427\0366427\_Prop ADA Plans.dgn

USER NAME = pletschr	DESIGNED -	REVISED -
PLOT SCALE = 10.0000' / 1"	DRAWN -	REVISED -
PLOT DATE = 12/15/2021	CHECKED -	REVISED -
	DATE -	REVISED -

**STATE OF ILLINOIS  
DEPARTMENT OF TRANSPORTATION**

SCALE:		SHEET OF SHEETS		STA. TO STA.		<b>ADA DETAILS ASH STREET NW QUADRANT</b>		
						F.A.P. RTE.	SECTION	COUNTY
						71	*	IROQUOIS

* (112 & 112Z) & (38-5HB-4)RS-3.5W			
TOTAL SHEETS	SHEET NO.	ILLINOIS	FED. AID PROJECT
40	19		
CONTRACT NO. 66K77			



SIDEWALK REM = 187.6 SQ FT

PAVEMENT REM = 8.4 SQ FT

CURB REM = 29.5 FT

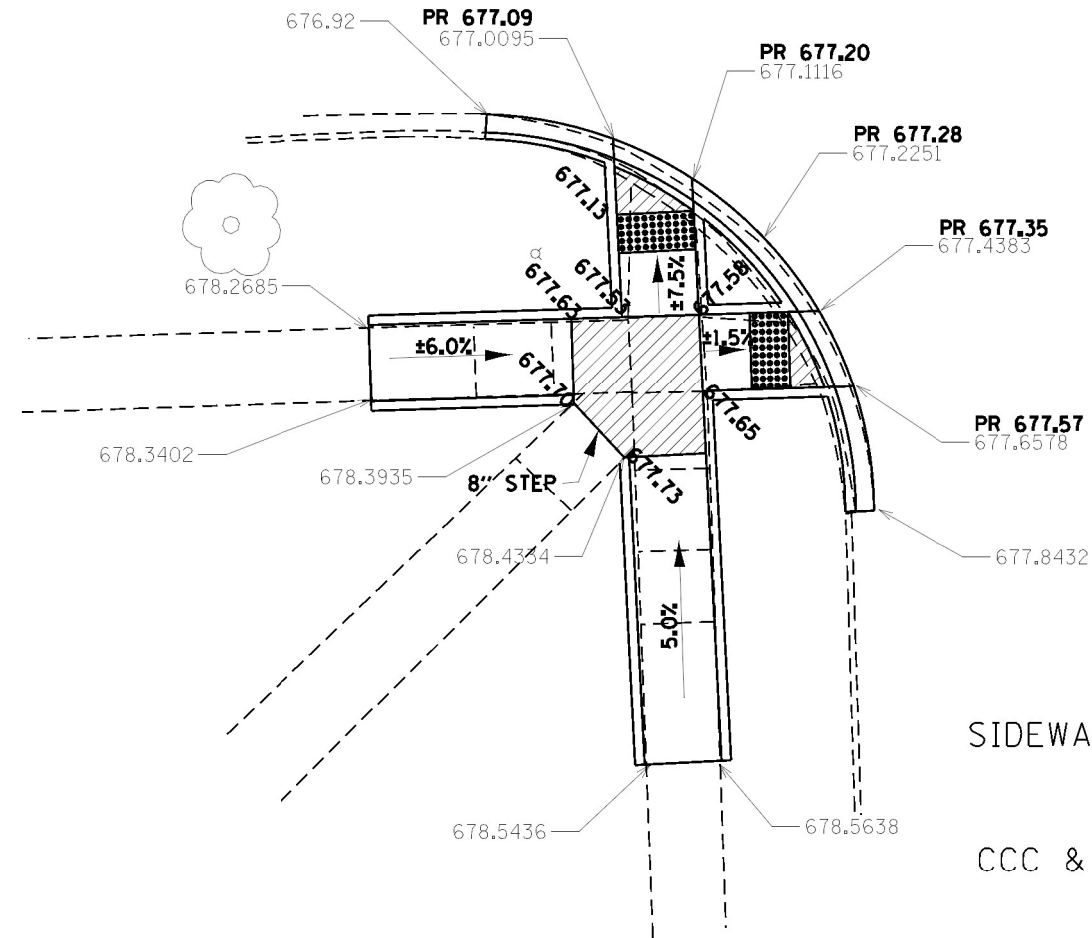

SIDEWALK 4" = 241.7 SQ FT

CCC & G = 30.5 FT

DETECTABLE WARNING =  
8.0 SQ FT + 8.0 SQ FT

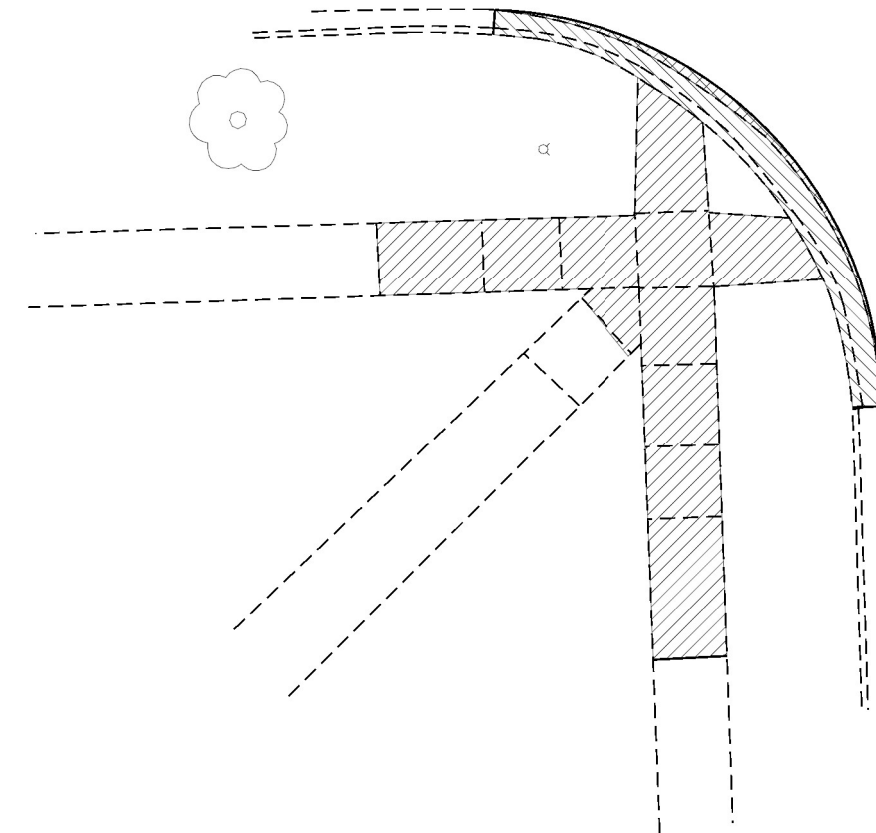

- CURB AND GUTTER REMOVAL
- SIDEWALK REMOVAL
- PAVEMENT REMOVAL
- DETECTABLE WARNING
- TURNING SPACE / LEVEL LANDING  
15% CROSS-SLOPE BOTH DIRECTION
- SODDING AREA  
INCLUDED IN SW WORK



NOTES:

1. SEE HIGHWAY STANDARDS 424001 - 424031 FOR MAX SLOPES AND ADDITIONAL REQUIREMENTS.
2. SEE HIGHWAY STANDARD 606001 FOR CURB AND GUTTER REQUIREMENTS NEXT TO ADA RAMPS.
3. ALL CROSS-SLOPES IN THE DIRECTION OF TRAVEL ARE AN ABSOLUTE MAXIMUM OF 2% LAYOUT SHOULD BE AT 1.5% TO ALLOW FOR ERROR WHILE REMAINING WITH THE MAXIMUM SLOPE.
4. SIDEWALK CURBS ARE SHOW ONLY AS REQUIRED BY FIELD CONDITIONS AND MAY BE OMITTED IF FOUND TO BE UNNECESSARY.
5. PEDESTRIAN PUSH BUTTON SIGN PAY ITEM TO BE INCIDENTAL TO THE PDESTRIAN PUSH BUTTON PAY ITEM.

MODEL: Default  
 FILE: Model - p:\mddot\Documents\DOT - Offices\District 3\Projects\03664271\03664271\CAD\Drawings\CAD\Sheets\03664271\_Proj\_ADA\_Plan.dgn

USER NAME = pletschr	DESIGNED -	REVISED -
PLOT SCALE = 10.0000' / 1"	DRAWN -	REVISED -
PLOT DATE = 12/15/2021	CHECKED -	REVISED -
	DATE -	REVISED -

**STATE OF ILLINOIS  
DEPARTMENT OF TRANSPORTATION**

**ADA DETAILS  
ASH STREET SW QUADRANT**

SCALE: SHEET OF SHEETS STA. TO STA.

\* (112 & 112Z) & (38-5HB-4)RS-3.5W

F.A.P. RTE.	SECTION	COUNTY	TOTAL SHEETS	SHEET NO.
71	*	IROQUOIS	40	20
CONTRACT NO. 66K77				
ILLINOIS FED. AID PROJECT				



SIDEWALK REM = 96.4 SQ FT



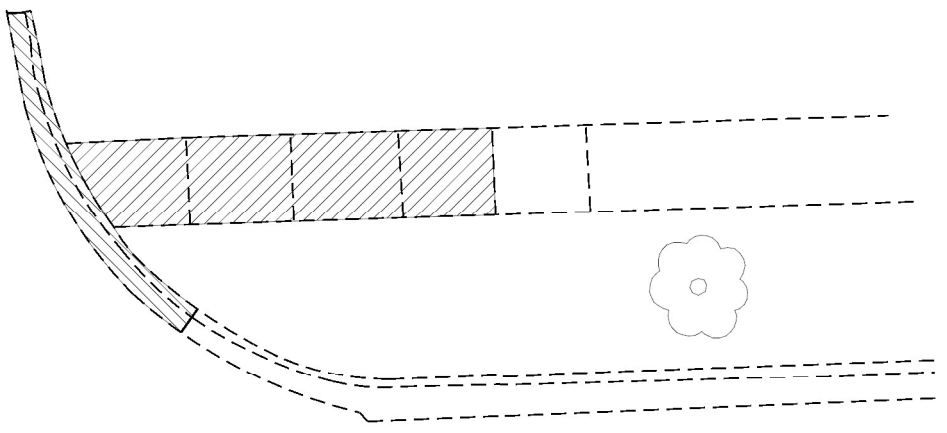
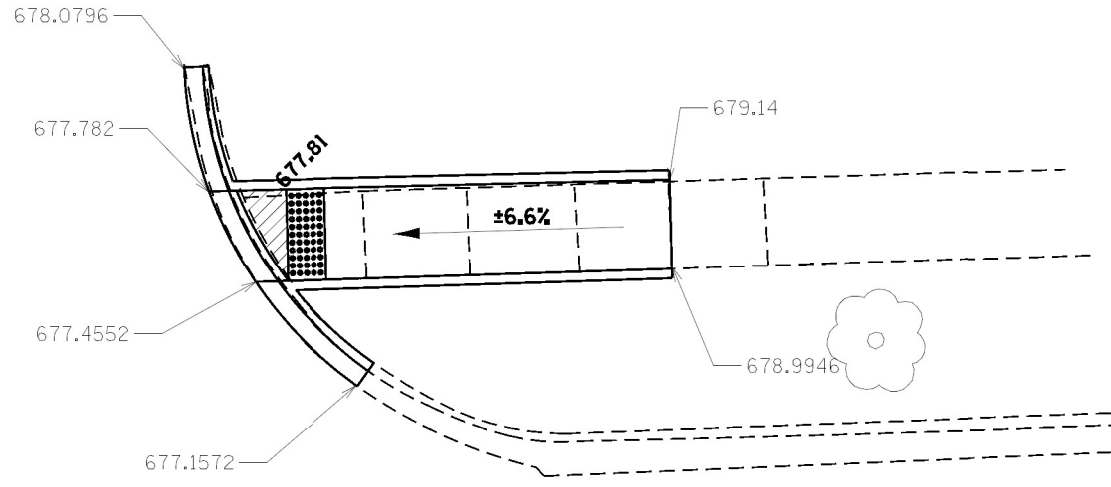



CURB REM = 19.0 FT



SIDEWALK 4" = 122.7 SQ FT

CCC & G = 19.0 FT

DETECTABLE WARNING = 10.0 SQ FT

-  CURB AND GUTTER REMOVAL
-  SIDEWALK REMOVAL
-  PAVEMENT REMOVAL
-  DETECTABLE WARNING
-  TURNING SPACE / LEVEL LANDING  
15% CROSS-SLOPE BOTH DIRECTION
-  SODDING AREA  
INCLUDED IN SW WORK

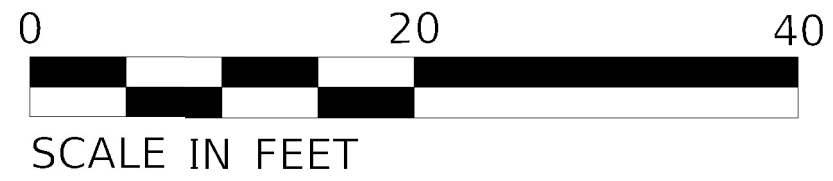

NOTES:

1. SEE HIGHWAY STANDARDS 424001 - 424031 FOR MAX SLOPES AND ADDITIONAL REQUIREMENTS.
2. SEE HIGHWAY STANDARD 606001 FOR CURB AND GUTTER REQUIREMENTS NEXT TO ADA RAMP.
3. ALL CROSS-SLOPES IN THE DIRECTION OF TRAVEL ARE AN ABSOLUTE MAXIMUM OF 2% LAYOUT SHOULD BE AT 1.5% TO ALLOW FOR ERROR WHILE REMAINING WITH THE MAXIMUM SLOPE.
4. SIDEWALK CURBS ARE SHOW ONLY AS REQUIRED BY FIELD CONDITIONS AND MAY BE OMITTED IF FOUND TO BE UNNECESSARY.
5. PEDESTRIAN PUSH BUTTON SIGN PAY ITEM TO BE INCIDENTAL TO THE PDESTRIAN PUSH BUTTON PAY ITEM.

MODEL: Default  
 FILE: Model - p:\mldoc\paw\berkeley.com\PROJECTS\Documents\DOT\_Offices\District\_3\Project\66K77\CADD\DWG\CAD\Sheet\66K77\_Proj\_ADA\_Plan.dgn

\*(112 & 112Z) & (38-5HB-4)RS-3.5W

USER NAME = pletschr PLOT SCALE = 10.0000" / 1' PLOT DATE = 12/15/2021	DESIGNED - DRAWN -	REVISED - REVISED -	<b>STATE OF ILLINOIS DEPARTMENT OF TRANSPORTATION</b>	<b>ADA DETAILS ASH STREET NE QUADRANT</b>		F.A.P. RTE. 71	SECTION *	COUNTY IROQUOIS	TOTAL SHEETS 40	SHEET NO. 21
	CHECKED - DATE -	REVISED - REVISED -		SCALE:	SHEET OF	SHEETS	STA. TO STA.	ILLINOIS FED. AID PROJECT CONTRACT NO. 66K77		

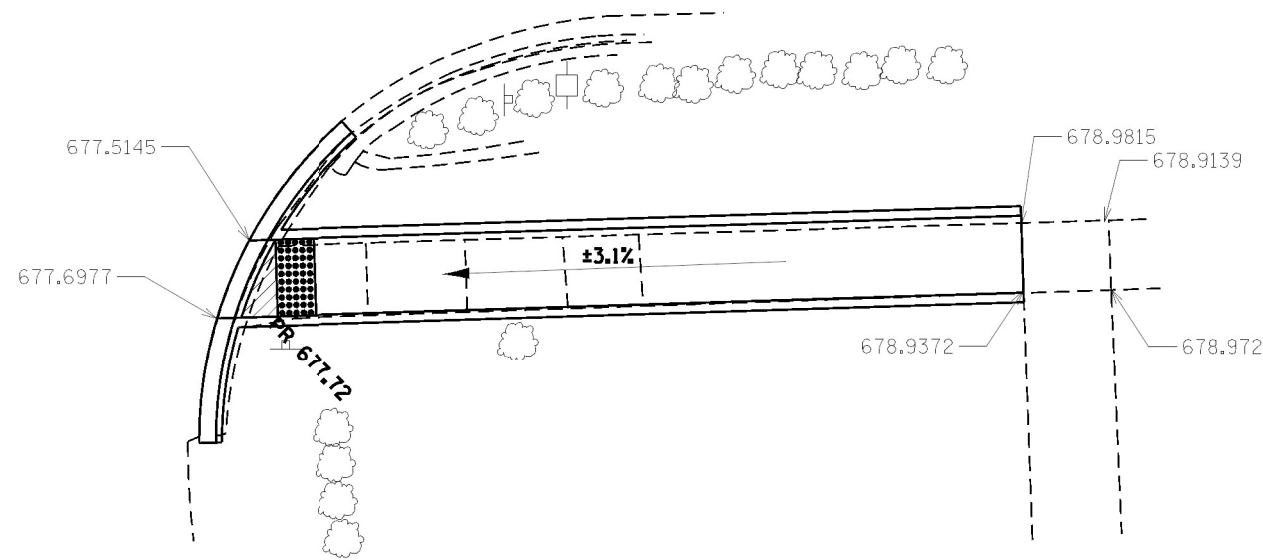

SIDEWALK 4" = 199.6 SQ FT

CCC & G = 17.0 FT

DETECTABLE WARNING =  
8.0 SQ FT

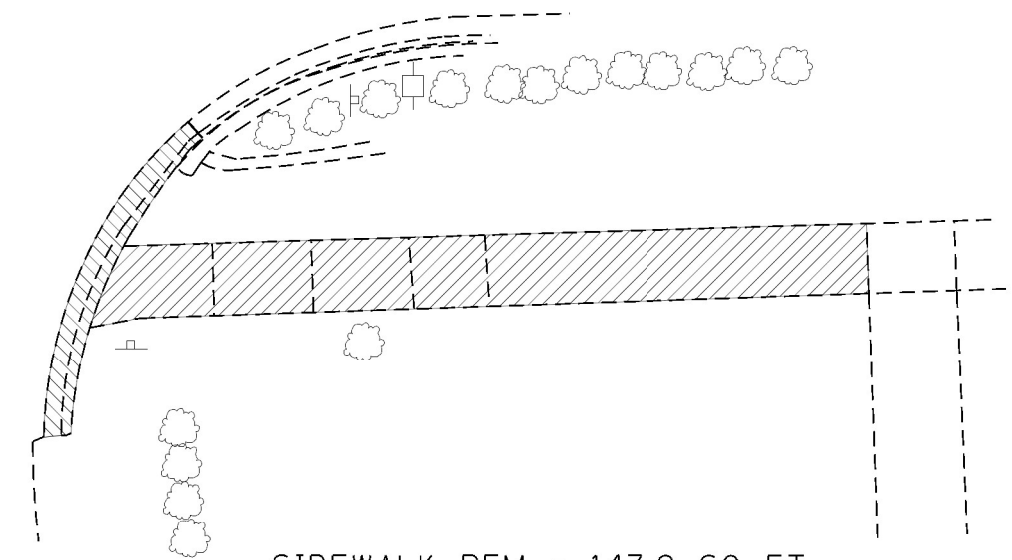

SIDEWALK REM = 147.9 SQ FT

CURB REM = 17.0 FT

- CURB AND GUTTER REMOVAL
- SIDEWALK REMOVAL
- PAVEMENT REMOVAL
- DETECTABLE WARNING
- TURNING SPACE / LEVEL LANDING  
15% CROSS-SLOPE BOTH DIRECTION
- SODDING AREA  
INCLUDED IN SW WORK



NOTES:

1. SEE HIGHWAY STANDARDS 424001 - 424031 FOR MAX SLOPES AND ADDITIONAL REQUIREMENTS.
2. SEE HIGHWAY STANDARD 606001 FOR CURB AND GUTTER REQUIREMENTS NEXT TO ADA RAMP.
3. ALL CROSS-SLOPES IN THE DIRECTION OF TRAVEL ARE AN ABSOLUTE MAXIMUM OF 2% LAYOUT SHOULD BE AT 1.5% TO ALLOW FOR ERROR WHILE REMAINING WITH THE MAXIMUM SLOPE.
4. SIDEWALK CURBS ARE SHOW ONLY AS REQUIRED BY FIELD CONDITIONS AND MAY BE OMITTED IF FOUND TO BE UNNECESSARY.
5. PEDESTRIAN PUSH BUTTON SIGN PAY ITEM TO BE INCIDENTAL TO THE PDESTRIAN PUSH BUTTON PAY ITEM.

MODEL: Default  
 FILE: Model - p:\mddot\paw\berkeley.com\PHWD\DOT\Documents\DOT\_Offices\Director\_3\Projects\0366427\ICDD\Draws\CAD\Sheets\0366427\_Proj\_ADA\_Plan.dgn

\*(112 & 112Z) & (38-5HB-4)RS-3.5W

USER NAME = pletschr	DESIGNED -	REVISED -
PLOT SCALE = 10.0000" / 1'	DRAWN -	REVISED -
PLOT DATE = 12/15/2021	CHECKED -	REVISED -
	DATE -	REVISED -

**STATE OF ILLINOIS  
DEPARTMENT OF TRANSPORTATION**

**ADA DETAILS  
ASH STREET SE QUADRANT**

SCALE: SHEET OF SHEETS STA. TO STA.

F.A.P. RTE.	SECTION	COUNTY	TOTAL SHEETS	SHEET NO.
71	*	IROQUOIS	40	22
CONTRACT NO. 66K77				
ILLINOIS FED. AID PROJECT				



SIDEWALK 4" = 136.1 SQ FT

CCC & G = 13.5 FT

DETECTABLE WARNING =  
8.0 SQ FT

SIDEWALK REM = 114.3 SQ FT

CURB REM = 13.5 FT

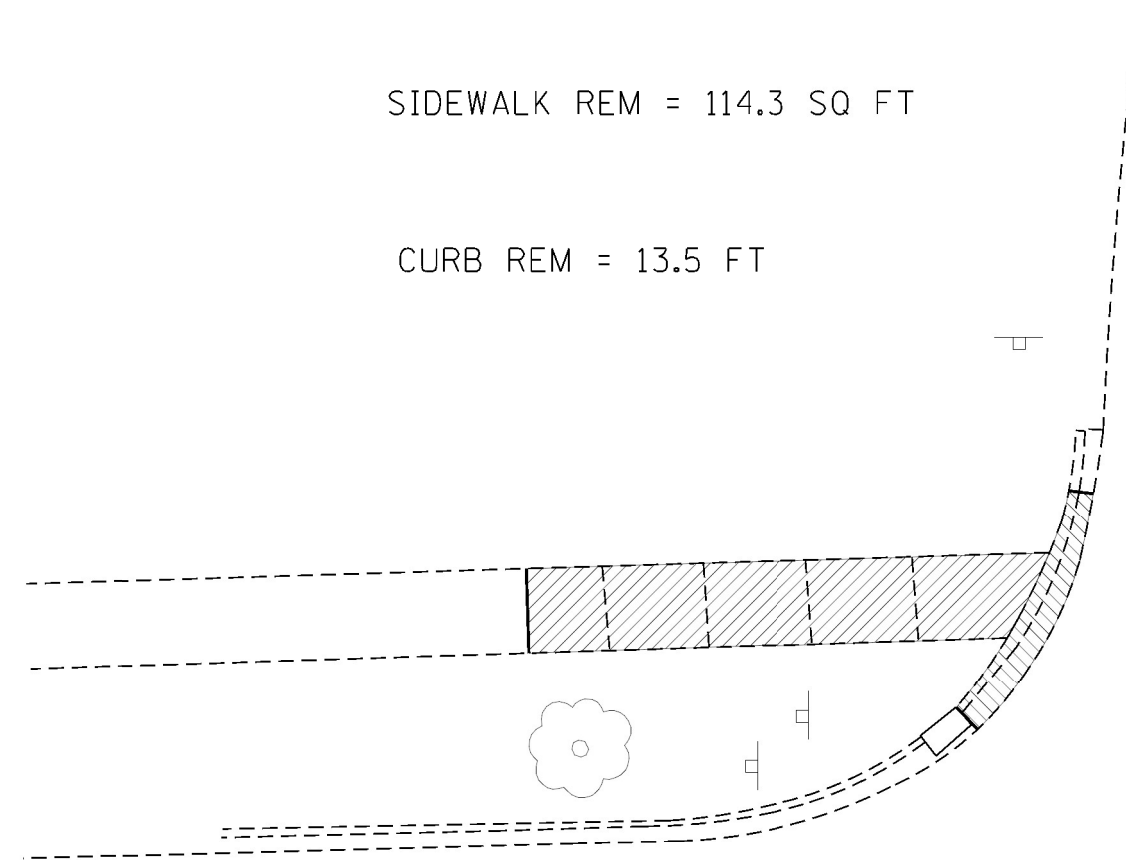
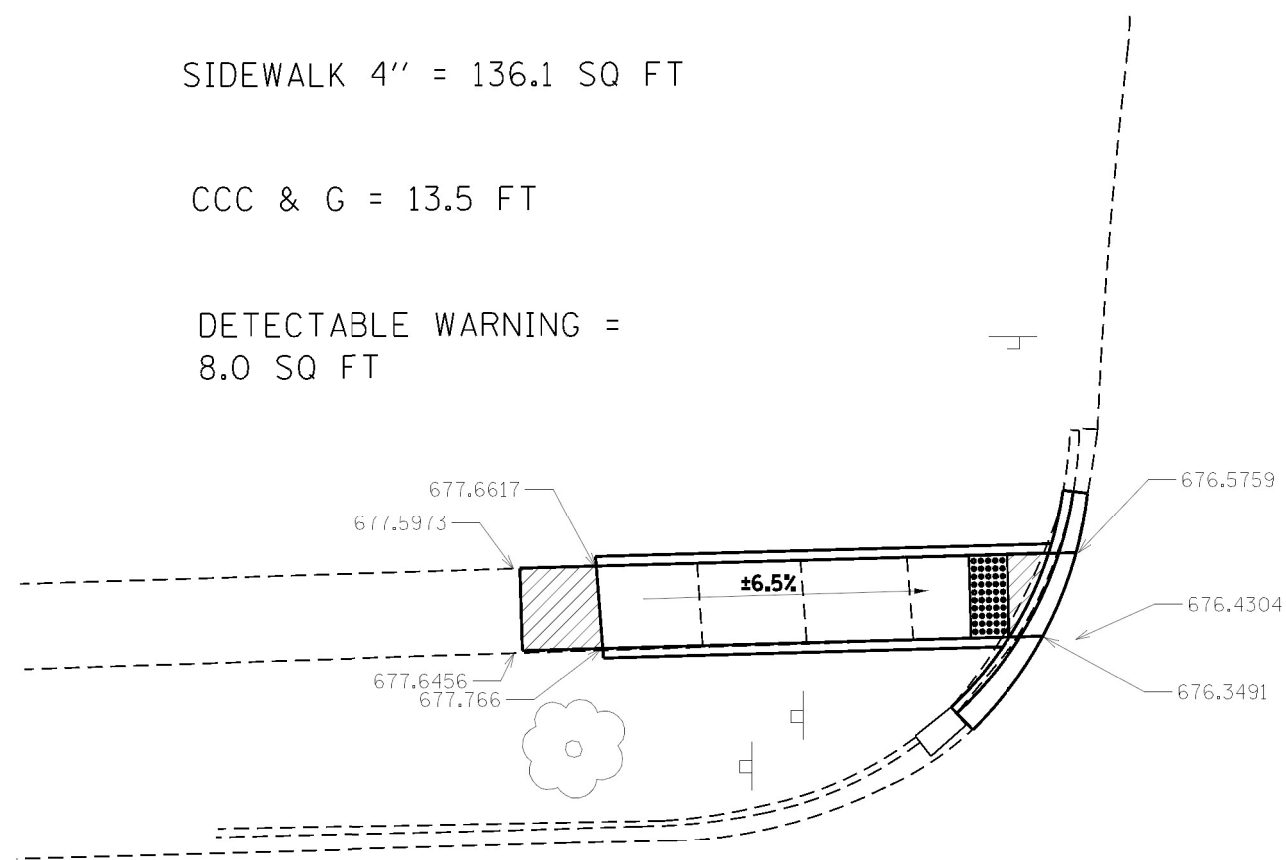

- CURB AND GUTTER REMOVAL
- SIDEWALK REMOVAL
- PAVEMENT REMOVAL
- DETECTABLE WARNING
- TURNING SPACE / LEVEL LANDING  
15% CROSS-SLOPE BOTH DIRECTION
- SODDING AREA  
INCLUDED IN SW WORK

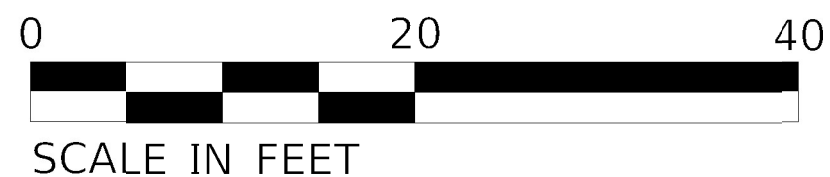

NOTES:

1. SEE HIGHWAY STANDARDS 424001 - 424031 FOR MAX SLOPES AND ADDITIONAL REQUIREMENTS.
2. SEE HIGHWAY STANDARD 606001 FOR CURB AND GUTTER REQUIREMENTS NEXT TO ADA RAMPS.
3. ALL CROSS-SLOPES IN THE DIRECTION OF TRAVEL ARE AN ABSOLUTE MAXIMUM OF 2% LAYOUT SHOULD BE AT 1.5% TO ALLOW FOR ERROR WHILE REMAINING WITH THE MAXIMUM SLOPE.
4. SIDEWALK CURBS ARE SHOW ONLY AS REQUIRED BY FIELD CONDITIONS AND MAY BE OMITTED IF FOUND TO BE UNNECESSARY.
5. PEDESTRIAN PUSH BUTTON SIGN PAY ITEM TO BE INCIDENTAL TO THE PDESTRIAN PUSH BUTTON PAY ITEM.

Model: Default  
 File: \\miller-pw-bentley.com\PWD\DOT\Documents\DOT\_Offices\Director\_3\Projects\03664271\CADD\Maple\03664271\_Proj\_ADA\_Plan.dgn

\*(112 & 112Z) & (38-5HB-4)RS-3.5W

USER NAME = pletschr	DESIGNED -	REVISED -
PLOT SCALE = 10.0000 "/math>ft.	DRAWN -	REVISED -
PLOT DATE = 12/15/2021	CHECKED -	REVISED -
	DATE -	REVISED -

**STATE OF ILLINOIS  
DEPARTMENT OF TRANSPORTATION**

**ADA DETAILS  
MAPLE STREET NW QUADRANT**

SCALE: SHEET OF SHEETS STA. TO STA.

F.A.P. RTE.	SECTION	COUNTY	TOTAL SHEETS	SHEET NO.
71	*	IROQUOIS	40	23
CONTRACT NO. 66K77				
ILLINOIS FED. AID PROJECT				



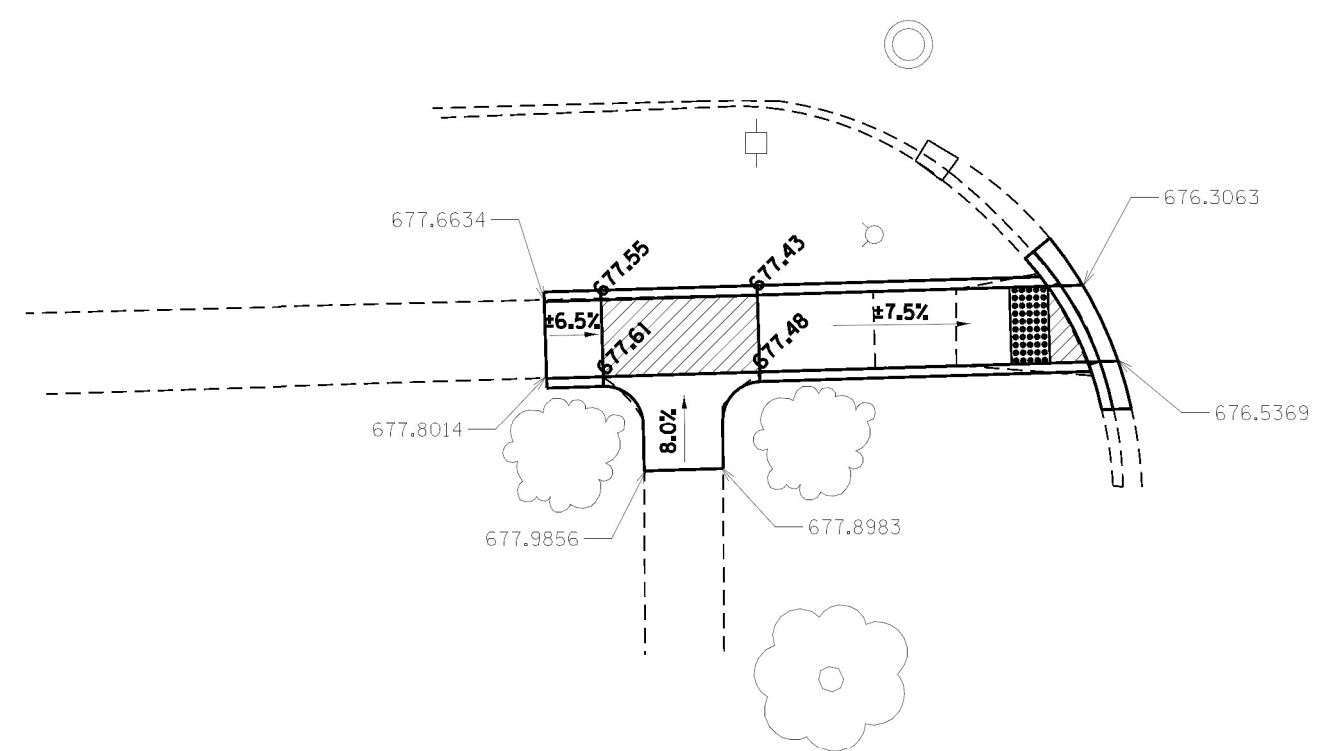

SIDEWALK 4" = 156.7 SQ FT

CCC & G = 9.5 FT

DETECTABLE WARNING = 8.0 SQ FT

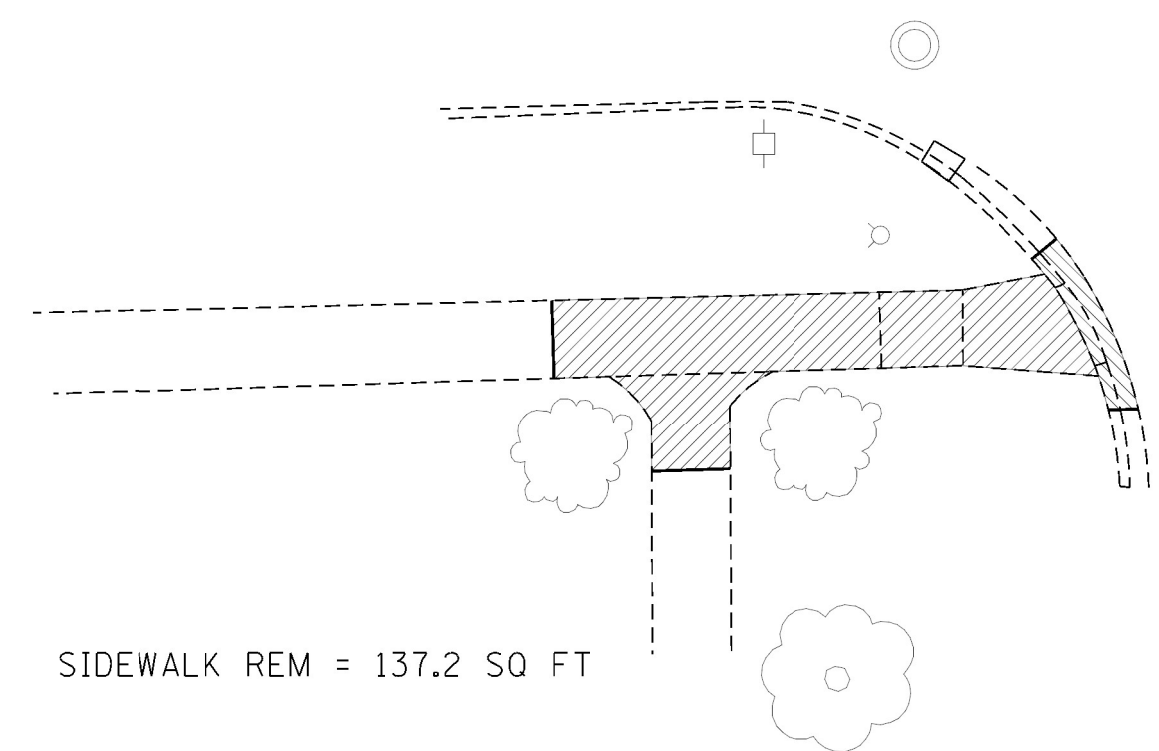

SIDEWALK REM = 137.2 SQ FT

CURB REM = 9.5 FT

-  CURB AND GUTTER REMOVAL
-  SIDEWALK REMOVAL
-  PAVEMENT REMOVAL
-  DETECTABLE WARNING
-  TURNING SPACE / LEVEL LANDING  
15% CROSS-SLOPE BOTH DIRECTION
-  SODDING AREA INCLUDED IN SW WORK

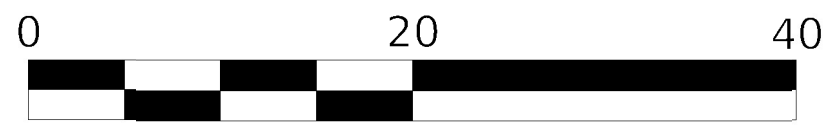

SCALE IN FEET

NOTES:

1. SEE HIGHWAY STANDARDS 424001 - 424031 FOR MAX SLOPES AND ADDITIONAL REQUIREMENTS.
2. SEE HIGHWAY STANDARD 606001 FOR CURB AND GUTTER REQUIREMENTS NEXT TO ADA RAMP.
3. ALL CROSS-SLOPES IN THE DIRECTION OF TRAVEL ARE AN ABSOLUTE MAXIMUM OF 2% LAYOUT SHOULD BE AT 1.5% TO ALLOW FOR ERROR WHILE REMAINING WITH THE MAXIMUM SLOPE.
4. SIDEWALK CURBS ARE SHOW ONLY AS REQUIRED BY FIELD CONDITIONS AND MAY BE OMITTED IF FOUND TO BE UNNECESSARY.
5. PEDESTRIAN PUSH BUTTON SIGN PAY ITEM TO BE INCIDENTAL TO THE PDESTRIAN PUSH BUTTON PAY ITEM.

MODEL: Default  
 FILE: \\miller-pw-bentley.com\PWD\DOT\Documents\DOT Office\District\_3\Project\0366K77\CADD\Maple\0366K77 Prop ADA Plans.dgn

USER NAME = pletschr	DESIGNED -	REVISED -
PLOT SCALE = 10.0000' / 1"	DRAWN -	REVISED -
PLOT DATE = 12/15/2021	CHECKED -	REVISED -
	DATE -	REVISED -

**STATE OF ILLINOIS**  
**DEPARTMENT OF TRANSPORTATION**

SCALE:		SHEET OF SHEETS		STA. TO STA.		<b>ADA DETAILS</b> <b>MAPLE STREET SW QUADRANT</b>	
						F.A.P. RTE. 71	SECTION *

* (112 & 112Z) & (38-5HB-4)RS-3.5W				
CONTRACT NO. 66K77				
ILLINOIS FED. AID PROJECT				

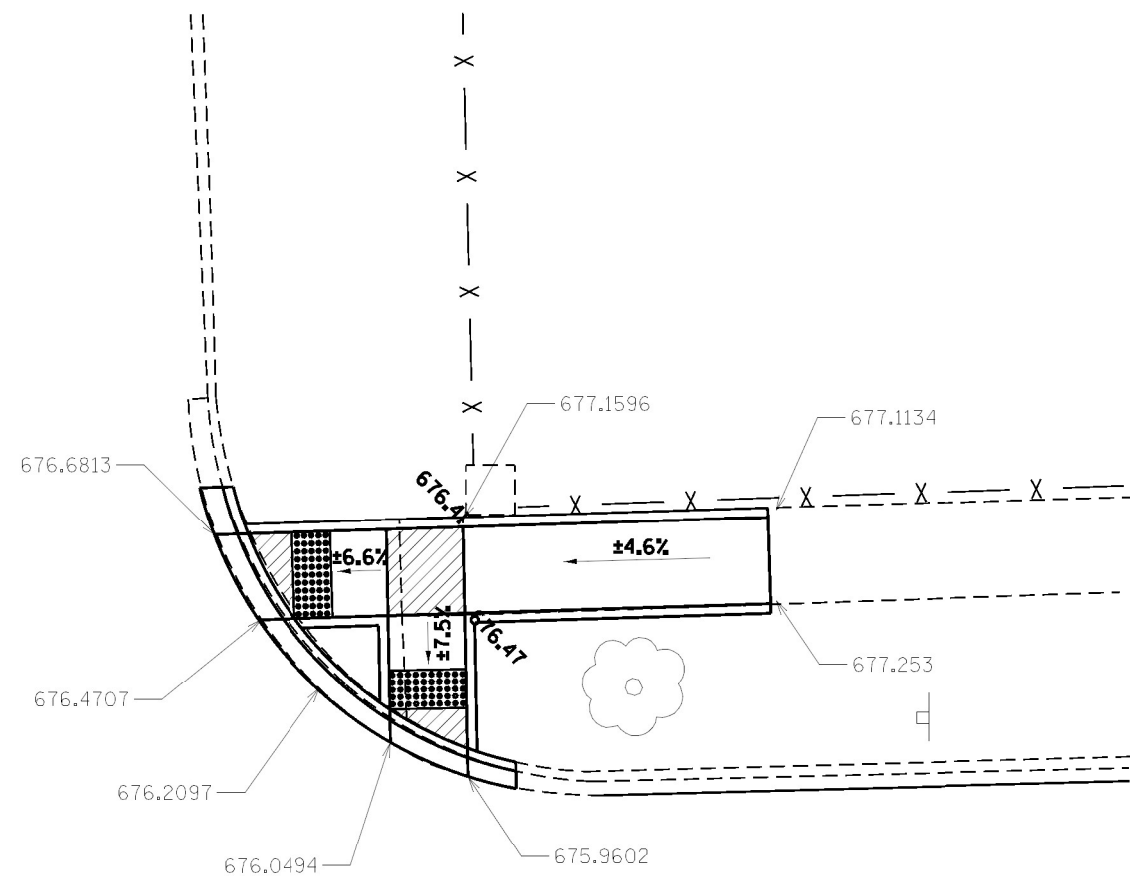

SIDEWALK 4" = 170.8 SQ FT

CCC & G = 22.5 FT

DETECTABLE WARNING =  
8.0 SQ FT + 8.0 SQ FT

- CURB AND GUTTER REMOVAL
- SIDEWALK REMOVAL
- PAVEMENT REMOVAL
- DETECTABLE WARNING
- TURNING SPACE / LEVEL LANDING  
15% CROSS-SLOPE BOTH DIRECTION
- SODDING AREA  
INCLUDED IN 'SW WORK

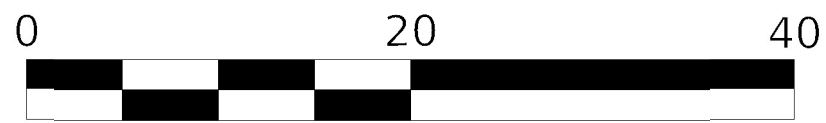

SCALE IN FEET

SIDEWALK REM = 151.2 SQ FT

CURB REM = 22.5 FT

NOTES:

1. SEE HIGHWAY STANDARDS 424001 - 424031 FOR MAX SLOPES AND ADDITIONAL REQUIREMENTS.
2. SEE HIGHWAY STANDARD 606001 FOR CURB AND GUTTER REQUIREMENTS NEXT TO ADA RAMPS.
3. ALL CROSS-SLOPES IN THE DIRECTION OF TRAVEL ARE AN ABSOLUTE MAXIMUM OF 2% LAYOUT SHOULD BE AT 1.5% TO ALLOW FOR ERROR WHILE REMAINING WITH THE MAXIMUM SLOPE.
4. SIDEWALK CURBS ARE SHOW ONLY AS REQUIRED BY FIELD CONDITIONS AND MAY BE OMITTED IF FOUND TO BE UNNECESSARY.
5. PEDESTRIAN PUSH BUTTON SIGN PAY ITEM TO BE INCIDENTAL TO THE PDESTRIAN PUSH BUTTON PAY ITEM.

MODEL: Default  
 FILE: \\miller-pw-bentley.com\PWD\DOT\Documents\DOT\_Offices\District\_3\Project\03664271\CD\Drawings\CAD\Sheets\03664271\_Proj\_ADA\_Plan.dgn

\*(112 & 112Z) & (38-5HB-4)RS-3.5W

USER NAME = pletschr	DESIGNED -	REVISED -
PLOT SCALE = 10.0000' / 1"	DRAWN -	REVISED -
PLOT DATE = 12/15/2021	CHECKED -	REVISED -
	DATE -	REVISED -

**STATE OF ILLINOIS  
DEPARTMENT OF TRANSPORTATION**

**ADA DETAILS  
MAPLE STREET NE QUADRANT**

SCALE: SHEET OF SHEETS STA. TO STA.

F.A.P. RTE.	SECTION	COUNTY	TOTAL SHEETS	SHEET NO.
71	*	IROQUOIS	40	25
CONTRACT NO. 66K77				
ILLINOIS FED. AID PROJECT				

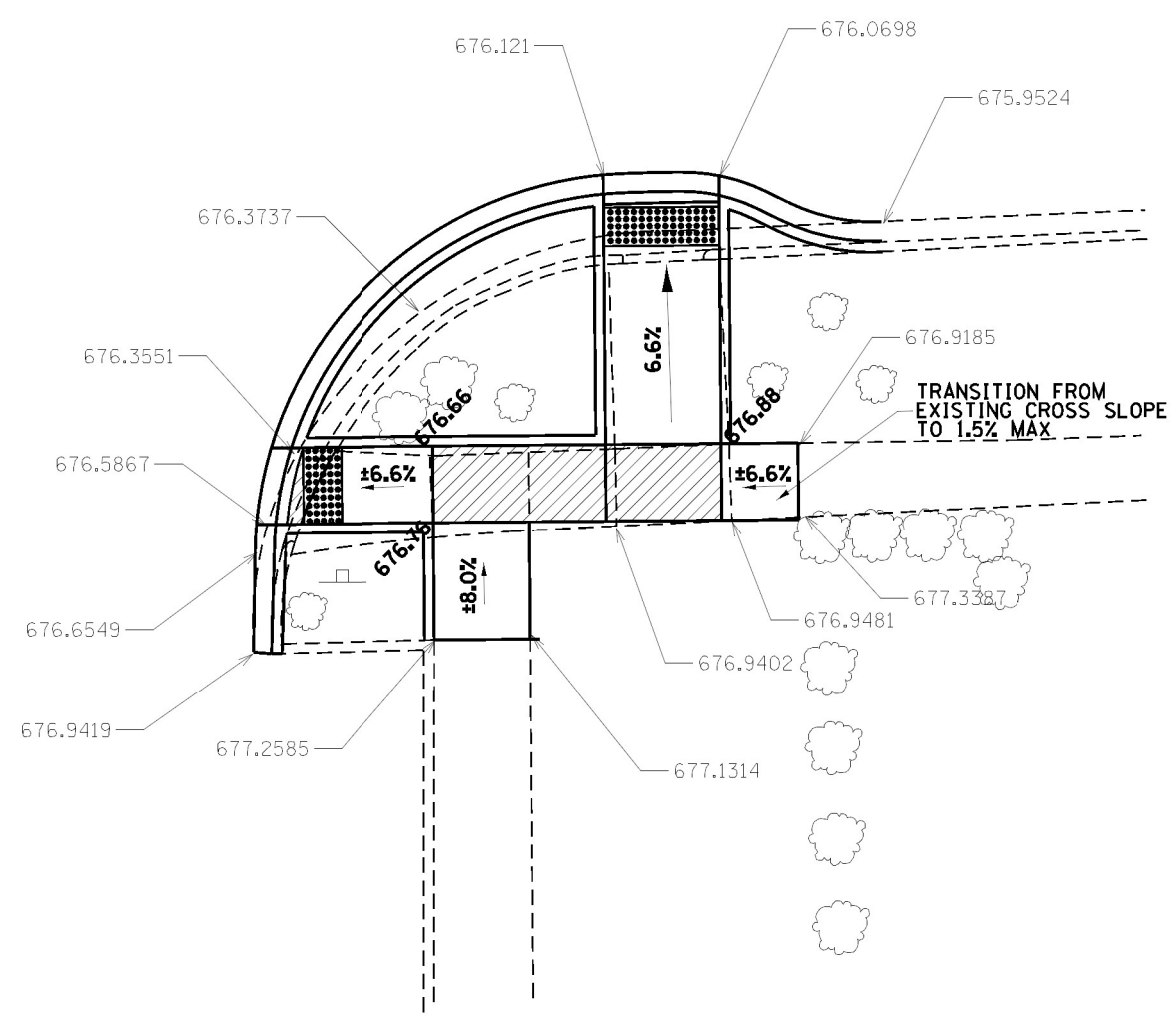

PAVEMENT REM = 92.3 SQ FT

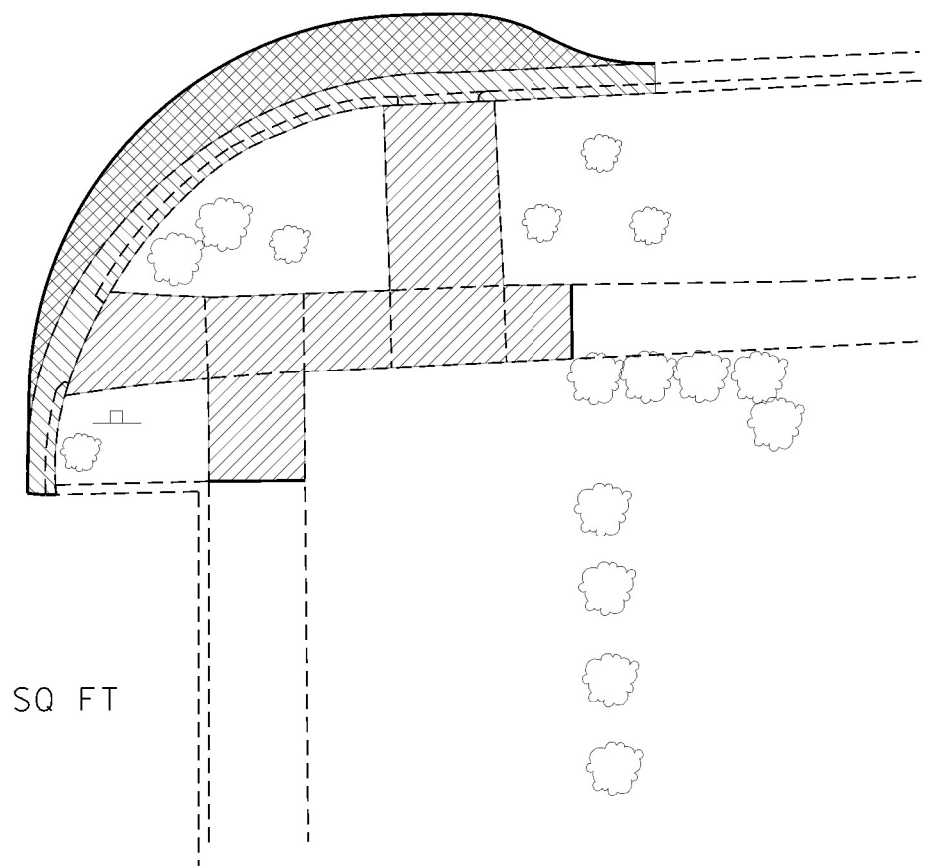

SIDEWALK REM = 191.5 SQ FT

CURB REM = 44.0 FT

SIDEWALK 4" = 238.0 SQ FT

CCC & G = 48.0 FT

DETECTABLE WARNING =  
8.0 SQ FT + 12.0 SQ FT

SODDING = 6.1 SQ YD

- CURB AND GUTTER REMOVAL
- SIDEWALK REMOVAL
- PAVEMENT REMOVAL
- DETECTABLE WARNING
- TURNING SPACE / LEVEL LANDING  
15% CROSS-SLOPE BOTH DIRECTION
- SODDING AREA  
INCLUDED IN SW WORK

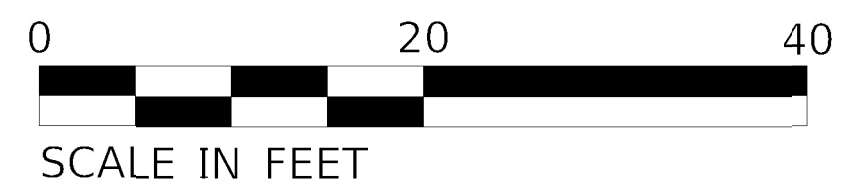

NOTES:

1. SEE HIGHWAY STANDARDS 424001 - 424031 FOR MAX SLOPES AND ADDITIONAL REQUIREMENTS.
2. SEE HIGHWAY STANDARD 606001 FOR CURB AND GUTTER REQUIREMENTS NEXT TO ADA RAMPS.
3. ALL CROSS-SLOPES IN THE DIRECTION OF TRAVEL ARE AN ABSOLUTE MAXIMUM OF 2% LAYOUT SHOULD BE AT 1.5% TO ALLOW FOR ERROR WHILE REMAINING WITH THE MAXIMUM SLOPE.
4. SIDEWALK CURBS ARE SHOW ONLY AS REQUIRED BY FIELD CONDITIONS AND MAY BE OMITTED IF FOUND TO BE UNNECESSARY.
5. PEDESTRIAN PUSH BUTTON SIGN PAY ITEM TO BE INCIDENTAL TO THE PDESTRIAN PUSH BUTTON PAY ITEM.

MODEL: Default  
 FILE: \\miller-prod\pwworking\pwworking.com\PROJECTS\66K77\CD\Drawings\CD\66K77\_Prop\_ADA\_Plan.dgn

USER NAME = pletschr	DESIGNED -	REVISED -
PLOT SCALE = 10.0000' / 1"	DRAWN -	REVISED -
PLOT DATE = 12/15/2021	CHECKED -	REVISED -
	DATE -	REVISED -

**STATE OF ILLINOIS  
DEPARTMENT OF TRANSPORTATION**

<b>ADA DETAILS MAPLE STREET SE QUADRANT</b>		F.A.P. RTE.	SECTION	COUNTY	TOTAL SHEETS	SHEET NO.
		71	*	IROQUOIS	40	26
SCALE:	SHEET	OF	SHEETS	STA.	TO	STA.

\* (112 & 112Z) & (38-5HB-4)RS-3.5W

CONTRACT NO. 66K77	
ILLINOIS	FED. AID PROJECT

SIDEWALK REM = 239.6 SQ FT



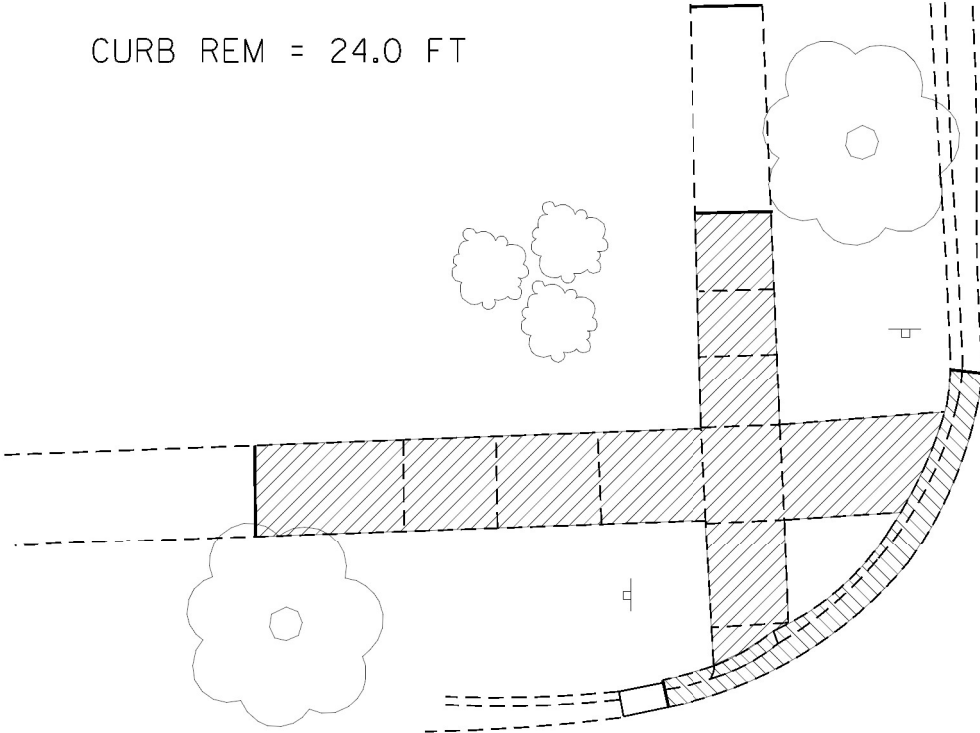
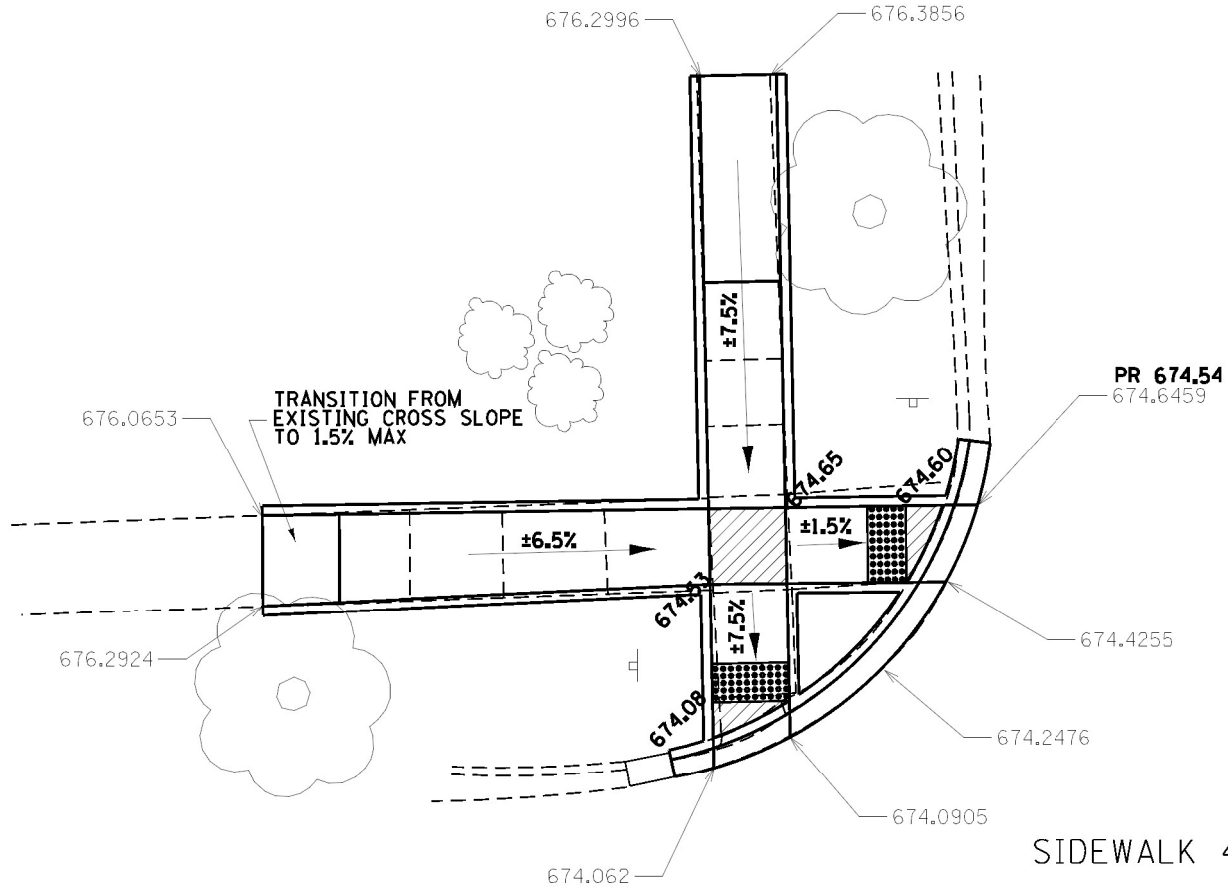



CURB REM = 24.0 FT



SIDEWALK 4" = 321.8 SQ FT

CCC & G = 24.0 FT

DETECTABLE WARNING = 8.0 SQ FT + 8.0 SQ FT

-  CURB AND GUTTER REMOVAL
-  SIDEWALK REMOVAL
-  PAVEMENT REMOVAL
-  DETECTABLE WARNING
-  TURNING SPACE / LEVEL LANDING  
15% CROSS-SLOPE BOTH DIRECTION
-  SODDING AREA INCLUDED IN SW WORK

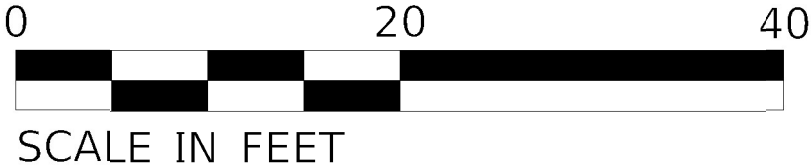

- NOTES:
1. SEE HIGHWAY STANDARDS 424001 - 424031 FOR MAX SLOPES AND ADDITIONAL REQUIREMENTS.
  2. SEE HIGHWAY STANDARD 606001 FOR CURB AND GUTTER REQUIREMENTS NEXT TO ADA RAMPS.
  3. ALL CROSS-SLOPES IN THE DIRECTION OF TRAVEL ARE AN ABSOLUTE MAXIMUM OF 2% LAYOUT SHOULD BE AT 1.5% TO ALLOW FOR ERROR WHILE REMAINING WITH THE MAXIMUM SLOPE.
  4. SIDEWALK CURBS ARE SHOW ONLY AS REQUIRED BY FIELD CONDITIONS AND MAY BE OMITTED IF FOUND TO BE UNNECESSARY.
  5. PEDESTRIAN PUSH BUTTON SIGN PAY ITEM TO BE INCIDENTAL TO THE PDESTRIAN PUSH BUTTON PAY ITEM.

MODEL: Default  
 FILE: Model - p:\mddot\Documents\DOT Office\District\_3\Project\03664271\CD\Drawings\ADA\Sheet\03664271\_Proj ADA Plan.dgn

USER NAME = pletschr	DESIGNED -	REVISED -
PLOT SCALE = 10.0000' / 1"	DRAWN -	REVISED -
PLOT DATE = 12/15/2021	CHECKED -	REVISED -
	DATE -	REVISED -

STATE OF ILLINOIS  
DEPARTMENT OF TRANSPORTATION

ADA DETAILS	
EVERGREEN STREET NW QUADRANT	
SCALE:	SHEET OF SHEETS STA. TO STA.

* (112 & 112Z) & (38-5HB-4)RS-3.5W				
F.A.P. RTE.	SECTION	COUNTY	TOTAL SHEETS	SHEET NO.
71	*	IROQUOIS	40	27
CONTRACT NO. 66K77				
ILLINOIS FED. AID PROJECT				

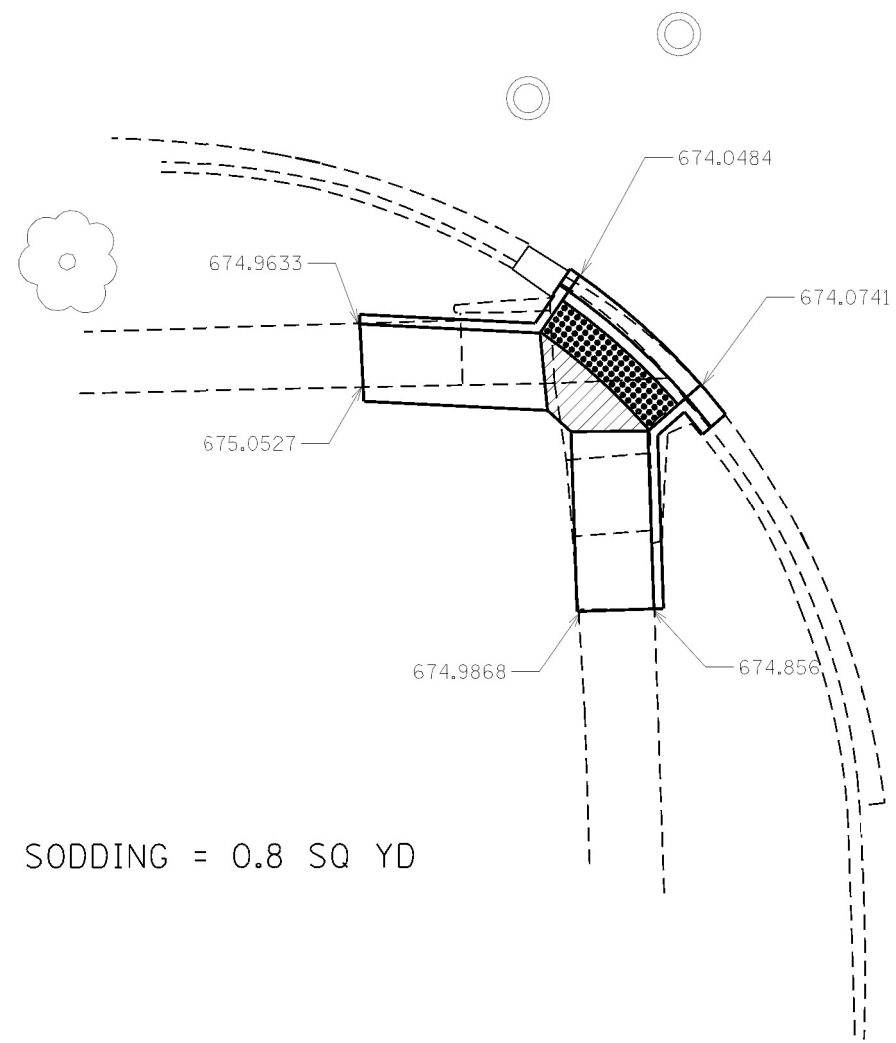

SODDING = 0.8 SQ YD

SIDEWALK 4" = 116.3 SQ FT

CCC & G = 11.0 FT

DETECTABLE WARNING = 16.0 SQ FT

- CURB AND GLTTER REMOVAL
- SIDEWALK REMOVAL
- PAVEMENT REMOVAL
- DETECTABLE WARNING
- TURNING SPACE / LEVEL LANDING  
15% CROSS-S\_OPE BOTH DIRECTION
- SODDING AREA  
INCLUDED IN SW WORK



SCALE IN FEET

SIDEWALK REM = 116.6 SQ FT

CURB REM = 11.0 FT

NOTES:

1. SEE HIGHWAY STANDARDS 424001 - 424031 FOR MAX SLOPES AND ADDITIONAL REQUIREMENTS.
2. SEE HIGHWAY STANDARD 606001 FOR CURB AND GUTTER REQUIREMENTS NEXT TO ADA RAMP.
3. ALL CROSS-SLOPES IN THE DIRECTION OF TRAVEL ARE AN ABSOLUTE MAXIMUM OF 2% LAYOUT SHOULD BE AT 1.5% TO ALLOW FOR ERROR WHILE REMAINING WITH THE MAXIMUM SLOPE.
4. SIDEWALK CURBS ARE SHOW ONLY AS REQUIRED BY FIELD CONDITIONS AND MAY BE OMITTED IF FOUND TO BE UNNECESSARY.
5. PEDESTRIAN PUSH BUTTON SIGN PAY ITEM TO BE INCIDENTAL TO THE PDESTRIAN PUSH BUTTON PAY ITEM.

MODEL: Default  
 FILE: Model - p:\mldoc\paw\berkeley.com\PROJECTS\Documents\DOT Office\District\_3\Project\3D366K77\CADD\Sheet\CAD\Sheet\3D366K77\_Proj\_ADA\_Plan.dgn

USER NAME = pletschr	DESIGNED -	REVISED -
PLOT SCALE = 10.0000 "/td> <td>DRAWN -</td> <td>REVISED -</td>	DRAWN -	REVISED -
PLOT DATE = 12/15/2021	CHECKED -	REVISED -
	DATE -	REVISED -

**STATE OF ILLINOIS  
DEPARTMENT OF TRANSPORTATION**

<b>ADA DETAILS EVERGREEN STREET SW QUADRANT</b>	
SCALE:	SHEET OF SHEETS STA. TO STA.

* (112 & 112Z) & (38-5HB-4)RS-3.5W				
F.A.P. RTE.	SECTION	COUNTY	TOTAL SHEETS	SHEET NO.
71	*	IROQUOIS	40	28
CONTRACT NO. 66K77				
ILLINOIS FED. AID PROJECT				



SIDEWALK 4" = 267.5 SQ FT

SIDEWALK REM = 230.9 SQ FT

CCC & G = 9.0 FT

CURB REM = 9.0 FT

DETECTABLE WARNING = 10.0 SQ FT

SODDING = 1.1 SQ YD

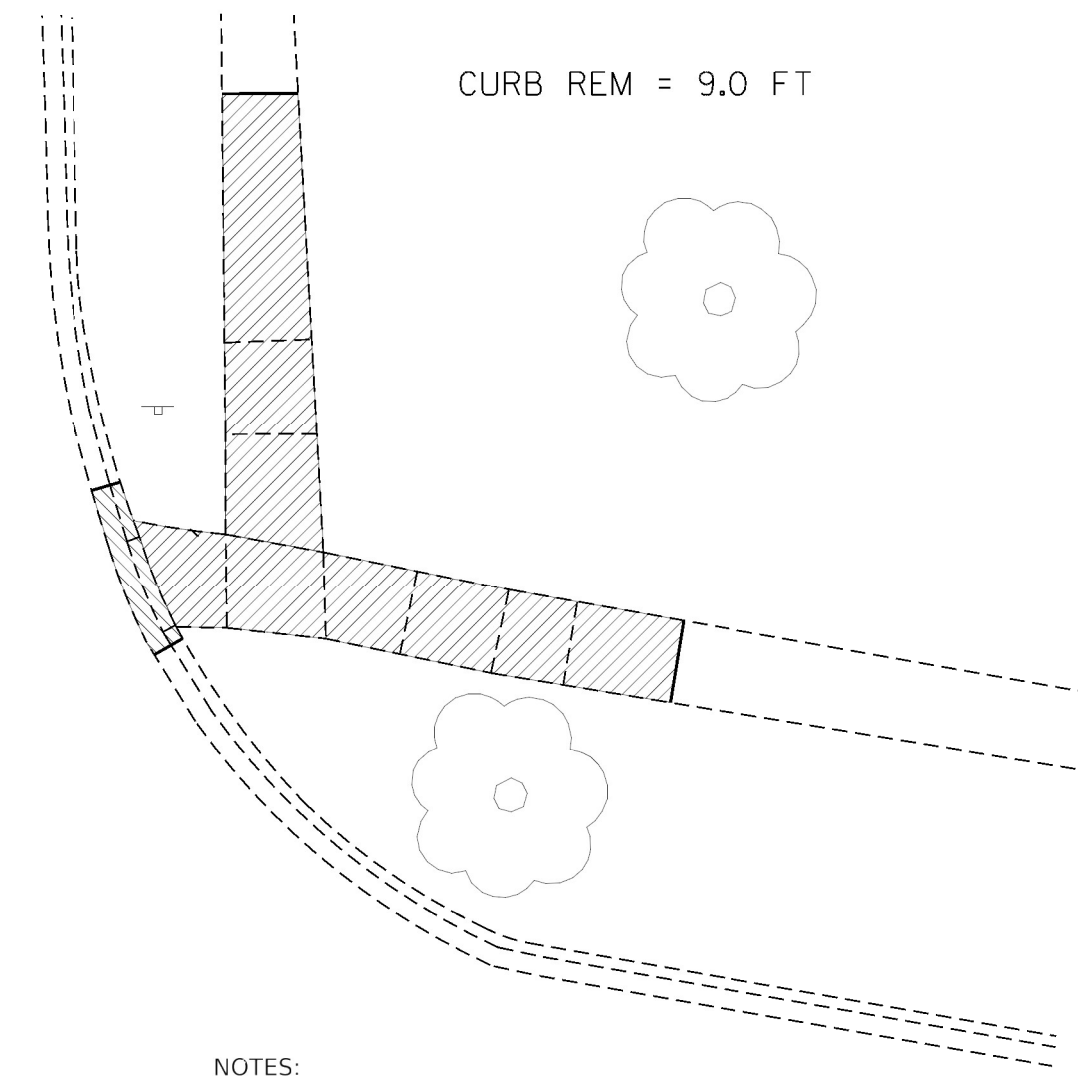
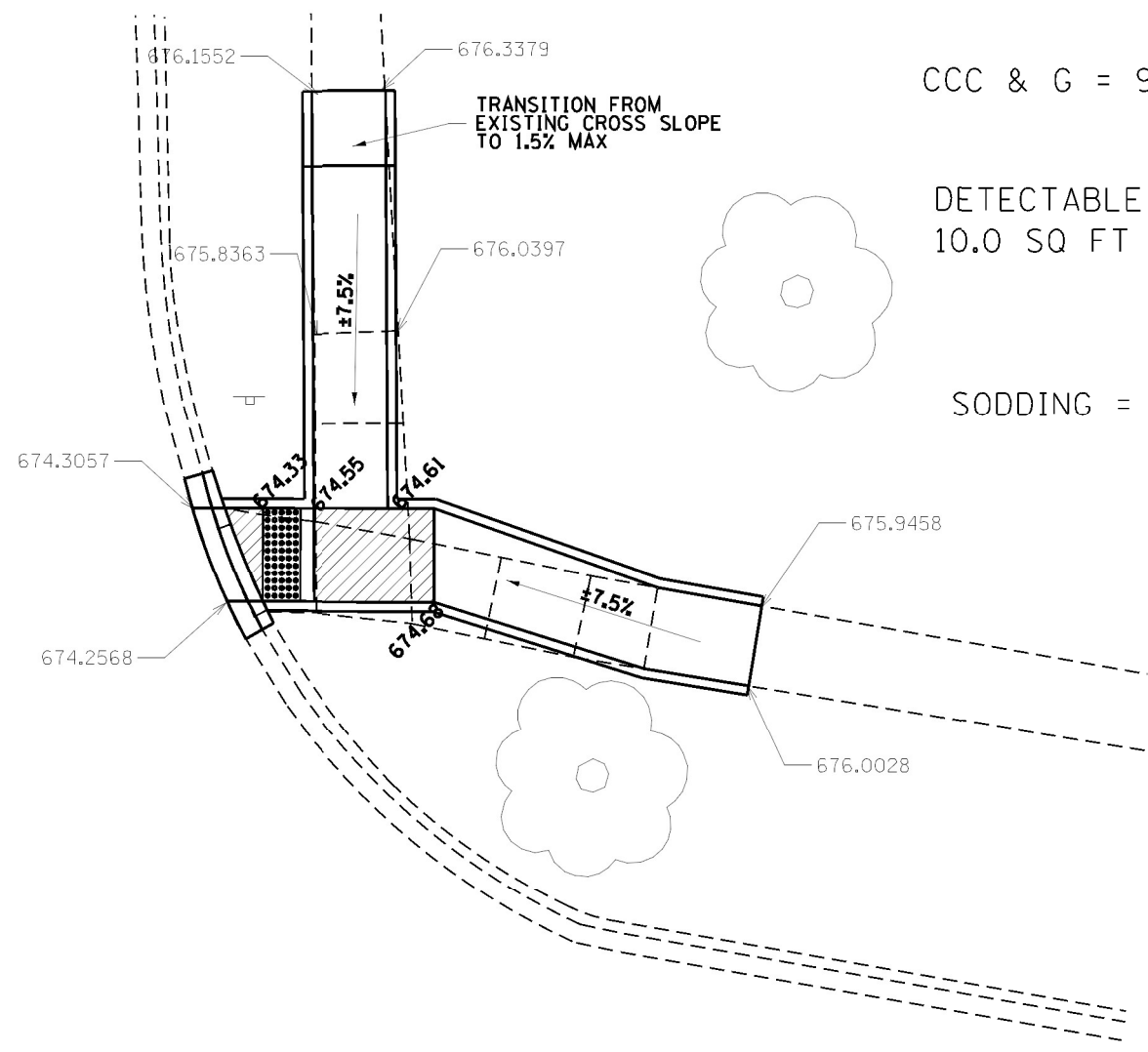

- CURB AND GUTTER REMOVAL
- SIDEWALK REMOVAL
- PAVEMENT REMOVAL
- DETECTABLE WARNING
- TURNING SPACE / LEVEL LANDING  
15% CROSS-SLOPE BOTH DIRECTION
- SODDING AREA  
INCLUDED IN SW WORK



SCALE IN FEET

NOTES:

1. SEE HIGHWAY STANDARDS 424001 - 424031 FOR MAX SLOPES AND ADDITIONAL REQUIREMENTS.
2. SEE HIGHWAY STANDARD 606001 FOR CURB AND GUTTER REQUIREMENTS NEXT TO ADA RAMPS.
3. ALL CROSS-SLOPES IN THE DIRECTION OF TRAVEL ARE AN ABSOLUTE MAXIMUM OF 2% LAYOUT SHOULD BE AT 1.5% TO ALLOW FOR ERROR WHILE REMAINING WITH THE MAXIMUM SLOPE.
4. SIDEWALK CURBS ARE SHOW ONLY AS REQUIRED BY FIELD CONDITIONS AND MAY BE OMITTED IF FOUND TO BE UNNECESSARY.
5. PEDESTRIAN PUSH BUTTON SIGN PAY ITEM TO BE INCIDENTAL TO THE PDESTRIAN PUSH BUTTON PAY ITEM.

MODEL: Default  
 FILE: Model - p:\moldoc\paw.bentley.com\PROJECTS\66K77\CADD\DATA\CADD\Sheet\0366K77\_Proj\_ADA\_Plan.dgn

USER NAME = pletschr	DESIGNED -	REVISED -
PLOT SCALE = 10.0000' / 1"	DRAWN -	REVISED -
PLOT DATE = 12/15/2021	CHECKED -	REVISED -
	DATE -	REVISED -

**STATE OF ILLINOIS  
DEPARTMENT OF TRANSPORTATION**

<b>ADA DETAILS</b>	
<b>EVERGREEN STREET NE QUADRANT</b>	
SCALE:	SHEET OF SHEETS STA. TO STA.

F.A.P. RTE.	SECTION	COUNTY	TOTAL SHEETS	SHEET NO.
71	*	IROQUOIS	40	29
CONTRACT NO. 66K77				
ILLINOIS FED. AID PROJECT				

\* (112 & 112Z) & (38-5HB-4)RS-3.5W

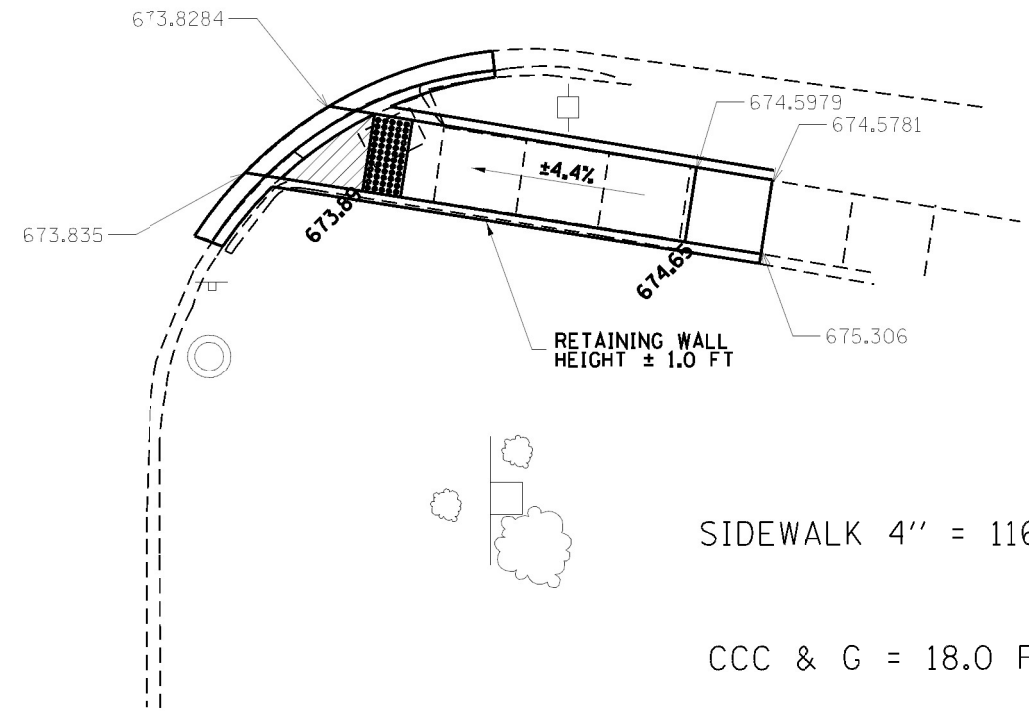

SIDEWALK 4" = 116.2 SQ FT

CCC & G = 18.0 FT

DETECTABLE WARNING =  
8.0 SQ FT

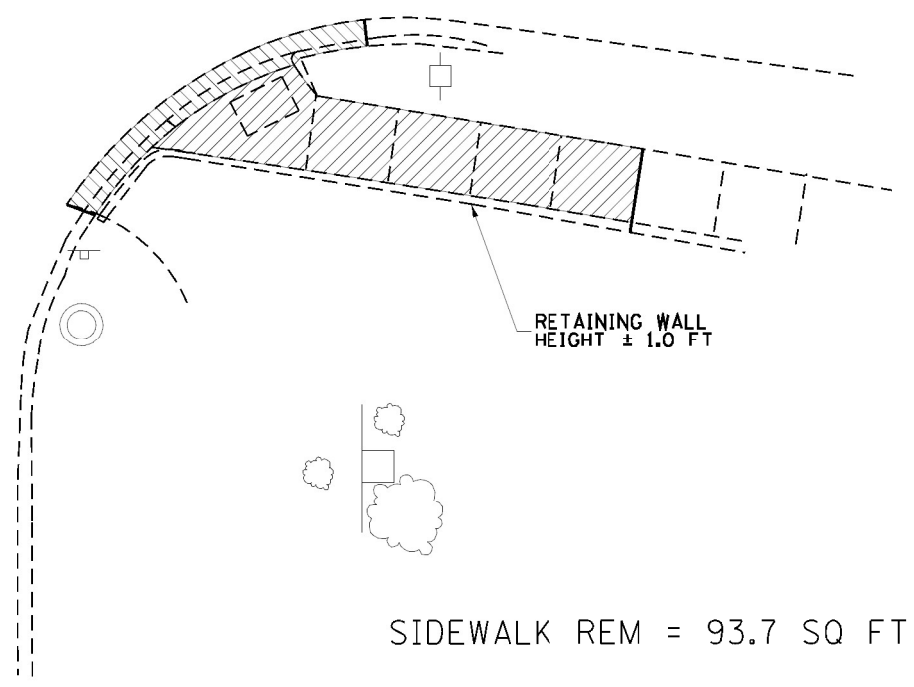

SIDEWALK REM = 93.7 SQ FT

CURB REM = 18.0 FT

- CURB AND GUTTER REMOVAL
- SIDEWALK REMOVAL
- PAVEMENT REMOVAL
- DETECTABLE WARNING
- TURNING SPACE / LEVEL LANDING  
15% CROSS-SLOPE BOTH DIRECTION
- SODDING AREA  
INCLUDED IN SW WORK

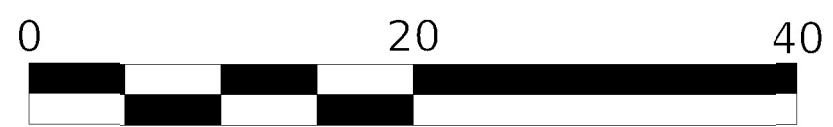

SCALE IN FEET

NOTES:

1. SEE HIGHWAY STANDARDS 424001 - 424031 FOR MAX SLOPES AND ADDITIONAL REQUIREMENTS.
2. SEE HIGHWAY STANDARD 606001 FOR CURB AND GUTTER REQUIREMENTS NEXT TO ADA RAMP.
3. ALL CROSS-SLOPES IN THE DIRECTION OF TRAVEL ARE AN ABSOLUTE MAXIMUM OF 2% LAYOUT SHOULD BE AT 1.5% TO ALLOW FOR ERROR WHILE REMAINING WITH THE MAXIMUM SLOPE.
4. SIDEWALK CURBS ARE SHOW ONLY AS REQUIRED BY FIELD CONDITIONS AND MAY BE OMITTED IF FOUND TO BE UNNECESSARY.
5. PEDESTRIAN PUSH BUTTON SIGN PAY ITEM TO BE INCIDENTAL TO THE PDESTRIAN PUSH BUTTON PAY ITEM.

MODEL: Default  
 FILE: Model - p:\miller\paw\_bentley.com\PROJECTS\66K77\CADD\DWG\CADD\DWG\66K77\_Proj\_ADA\_Plan.dgn

USER NAME = pletschr	DESIGNED -	REVISED -
PLOT SCALE = 10.0000" / 1'	DRAWN -	REVISED -
PLOT DATE = 12/15/2021	CHECKED -	REVISED -
	DATE -	REVISED -

**STATE OF ILLINOIS**  
**DEPARTMENT OF TRANSPORTATION**

<b>ADA DETAILS</b>	
<b>EVERGREEN STREET SE QUADRANT</b>	
SCALE:	SHEET OF SHEETS STA. TO STA.

F.A.P. RTE.	SECTION	COUNTY	TOTAL SHEETS	SHEET NO.
71	*	IROQUOIS	40	30
CONTRACT NO. 66K77				
ILLINOIS FED. AID PROJECT				

\* (112 & 112Z) & (38-5HB-4)RS-3.5W



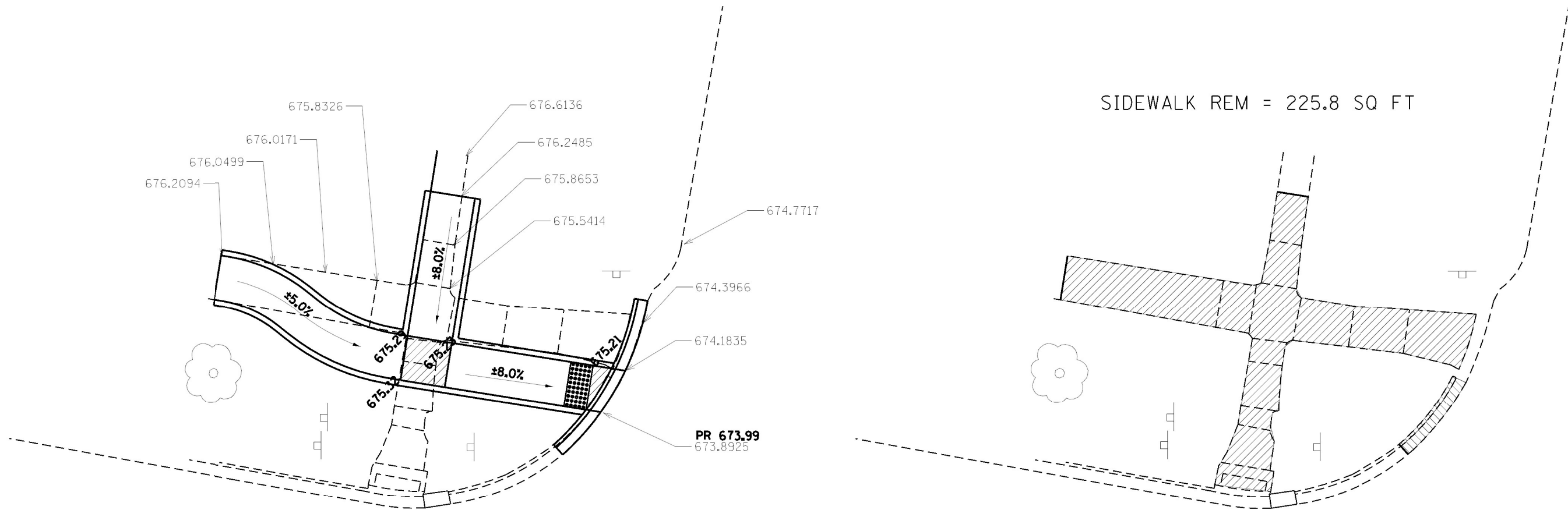

SIDEWALK REM = 225.8 SQ FT







SIDEWALK 4" = 242.8 SQ FT

CURB REM = 8.0 FT

CCC & G = 16.0 FT

SODDING = 9.8 SQ YD

DETECTABLE WARNING = 8.0 SQ FT

-  CURB AND GUTTER REMOVAL
-  SIDEWALK REMOVAL
-  PAVEMENT REMOVAL
-  DETECTABLE WARNING
-  TURNING SPACE / LEVEL LANDING 15% CROSS-SLOPE BOTH DIRECTION
-  SODDING AREA INCLUDED IN SW WORK



- NOTES:
- SEE HIGHWAY STANDARDS 424001 - 424031 FOR MAX SLOPES AND ADDITIONAL REQUIREMENTS.
  - SEE HIGHWAY STANDARD 606001 FOR CURB AND GUTTER REQUIREMENTS NEXT TO ADA RAMPS.
  - ALL CROSS-SLOPES IN THE DIRECTION OF TRAVEL ARE AN ABSOLUTE MAXIMUM OF 2% LAYOUT SHOULD BE AT 1.5% TO ALLOW FOR ERROR WHILE REMAINING WITH THE MAXIMUM SLOPE.
  - SIDEWALK CURBS ARE SHOW ONLY AS REQUIRED BY FIELD CONDITIONS AND MAY BE OMITTED IF FOUND TO BE UNNECESSARY.
  - PEDESTRIAN PUSH BUTTON SIGN PAY ITEM TO BE INCIDENTAL TO THE PDESTRIAN PUSH BUTTON PAY ITEM.

MODEL: Default  
 FILE: Model - p:\w\illdot\paw\berkeley.com\PROJECTS\66K77\CADD\DWG\CADD\DWG\66K77\_Proj\_ADA\_Plan.dwg

\*(112 & 112Z) & (38-5HB-4)RS-3.5W

USER NAME = pletschr	DESIGNED -	REVISED -
PLOT SCALE = 10.0000" / 1'	DRAWN -	REVISIED -
PLOT DATE = 12/15/2021	CHECKED -	REVISIED -
	DATE -	REVISIED -

**STATE OF ILLINOIS  
DEPARTMENT OF TRANSPORTATION**

<b>ADA DETAILS</b>	
<b>WALNUT STREET NW QUADRANT</b>	
SCALE:	SHEET OF SHEETS STA. TO STA.

F.A.P. RTE.	SECTION	COUNTY	TOTAL SHEETS	SHEET NO.
71	*	IROQUOIS	40	31
CONTRACT NO. 66K77				
ILLINOIS FED. AID PROJECT				

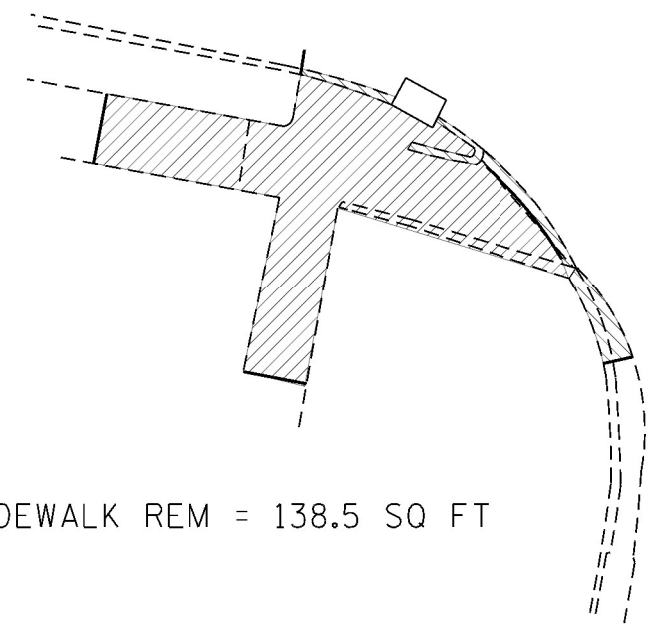
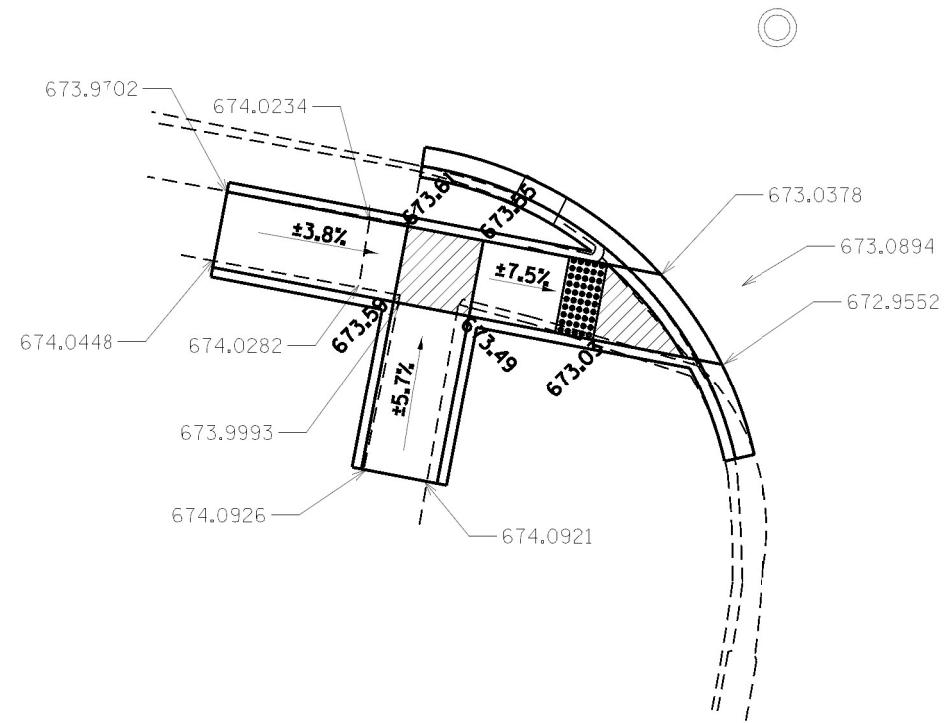







SIDEWALK REM = 138.5 SQ FT

CURB REM = 24.0 FT

SIDEWALK 4" = 155.5 SQ FT

CCC & G = 24.0 FT

DETECTABLE WARNING = 8.0 SQ FT

-  CURB AND GUTTER REMOVAL
-  SIDEWALK REMOVAL
-  PAVEMENT REMOVAL
-  DETECTABLE WARNING
-  TURNING SPACE / LEVEL LANDING  
15% CROSS-SLOPE BOTH DIRECTION
-  SODDING AREA INCLUDED IN SW WORK

- NOTES:
- SEE HIGHWAY STANDARDS 424001 - 424031 FOR MAX SLOPES AND ADDITIONAL REQUIREMENTS.
  - SEE HIGHWAY STANDARD 606001 FOR CURB AND GUTTER REQUIREMENTS NEXT TO ADA RAMPS.
  - ALL CROSS-SLOPES IN THE DIRECTION OF TRAVEL ARE AN ABSOLUTE MAXIMUM OF 2% LAYOUT SHOULD BE AT 1.5% TO ALLOW FOR ERROR WHILE REMAINING WITH THE MAXIMUM SLOPE.
  - SIDEWALK CURBS ARE SHOW ONLY AS REQUIRED BY FIELD CONDITIONS AND MAY BE OMITTED IF FOUND TO BE UNNECESSARY.
  - PEDESTRIAN PUSH BUTTON SIGN PAY ITEM TO BE INCIDENTAL TO THE PDESTRIAN PUSH BUTTON PAY ITEM.

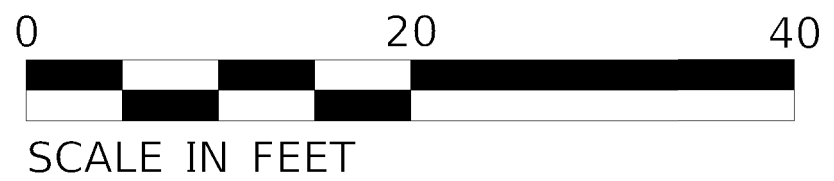

MODEL: Default  
 FILE: Model - p:\mwdot\paw\berkeley.com\pwwd\DOT\Documents\DOT\_Offices\Director\_3\Project\1036647\1036647\1036647\_Prop ADA Plans.dgn

USER NAME = pletschr DESIGNED - DRAWN - PLOT SCALE = 10.0000" / 1" PLOT DATE = 12/15/2021				DESIGNED - REVISIONS - CHECKED - DATE -				REVISED - REVISED - REVISED - REVISED -				<b>STATE OF ILLINOIS DEPARTMENT OF TRANSPORTATION</b>				<b>ADA DETAILS WALNUT STREET SW QUADRANT</b>				F.A.P. RTE. 71 SECTION * COUNTY IROQUOIS TOTAL SHEETS 40 SHEET NO. 32 CONTRACT NO. 66K77	
SCALE:				SHEET				OF				SHEETS				STA. TO STA.		ILLINOIS FED. AID PROJECT			

\* (112 & 112Z) & (38-5HB-4)RS-3.5W

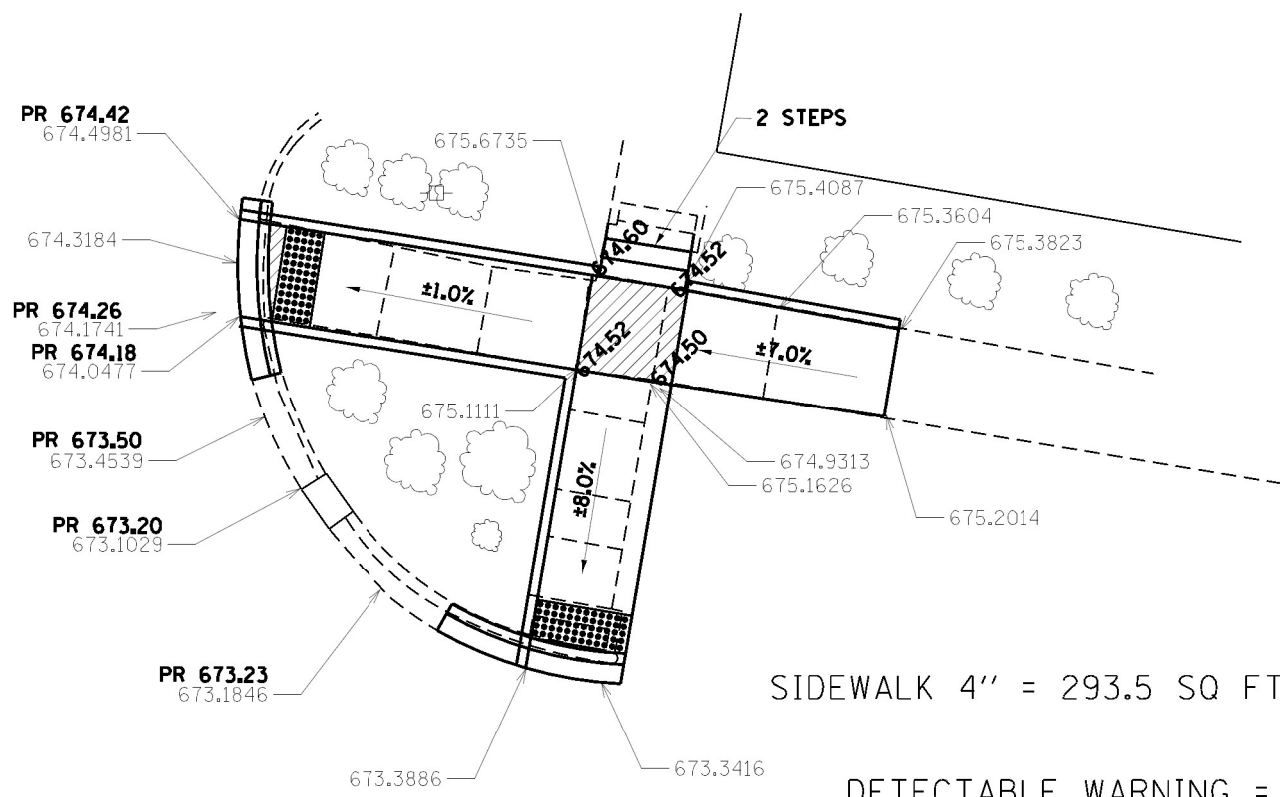

CCC & G = 18.5 FT

SIDEWALK 4" = 293.5 SQ FT

DETECTABLE WARNING =  
10.0 SQ FT + 10.0 SQ FT

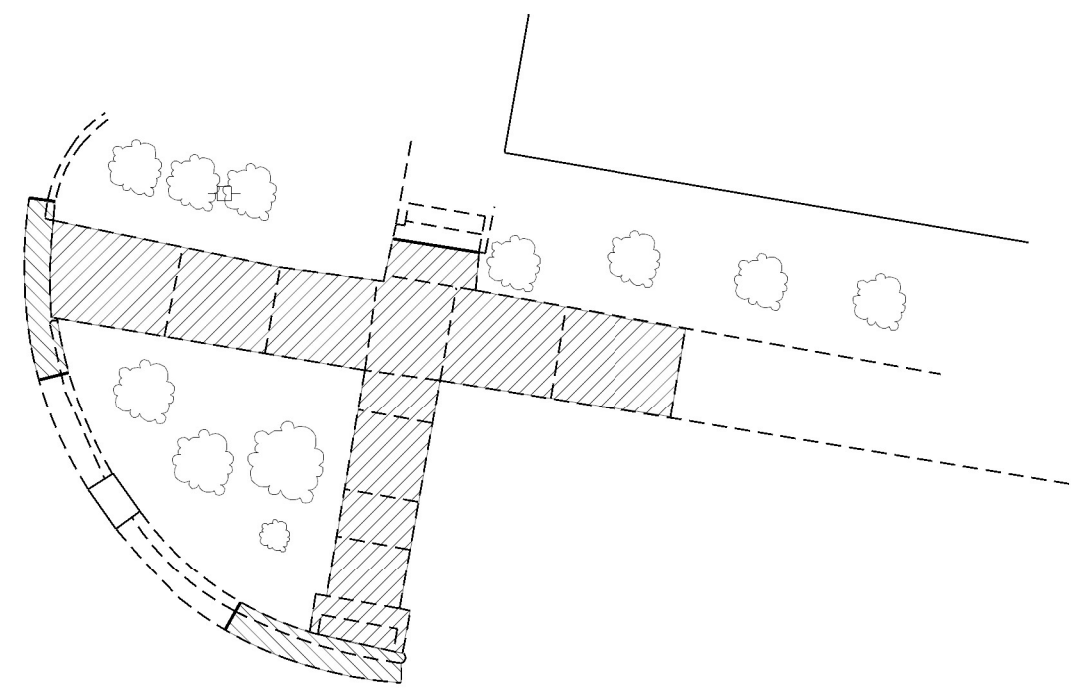

CURB REM = 18.5 FT

SIDEWALK REM = 225.7 SQ FT

- CURB AND GUTTER REMOVAL
- SIDEWALK REMOVAL
- PAVEMENT REMOVAL
- DETECTABLE WARNING
- TURNING SPACE / LEVEL LANDING  
15% CROSS-SLOPE BOTH DIRECTION
- SODDING AREA  
INCLUDED IN SW WORK

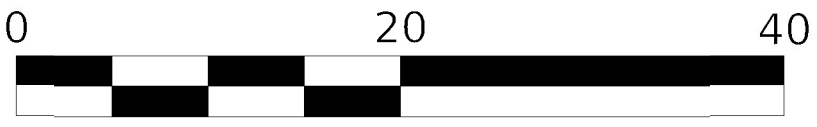

SCALE IN FEET

NOTES:

1. SEE HIGHWAY STANDARDS 424001 - 424031 FOR MAX SLOPES AND ADDITIONAL REQUIREMENTS.
2. SEE HIGHWAY STANDARD 606001 FOR CURB AND GUTTER REQUIREMENTS NEXT TO ADA RAMP.
3. ALL CROSS-SLOPES IN THE DIRECTION OF TRAVEL ARE AN ABSOLUTE MAXIMUM OF 2% LAYOUT SHOULD BE AT 1.5% TO ALLOW FOR ERROR WHILE REMAINING WITH THE MAXIMUM SLOPE.
4. SIDEWALK CURBS ARE SHOW ONLY AS REQUIRED BY FIELD CONDITIONS AND MAY BE OMITTED IF FOUND TO BE UNNECESSARY.
5. PEDESTRIAN PUSH BUTTON SIGN PAY ITEM TO BE INCIDENTAL TO THE PDESTRIAN PUSH BUTTON PAY ITEM.

MODEL: Default  
 FILE: \\miller-pw-bentley.com\PWD\DOT\Documents\DOT\_Offices\Director\_3\Projects\0366427\CD\Drawings\0366427\_Proj\_ADA\_Plan.dgn

\*(112 & 112Z) & (38-5HB-4)RS-3.5W

	USER NAME = plietschr	DESIGNED -	REVISED -	<b>STATE OF ILLINOIS DEPARTMENT OF TRANSPORTATION</b>	<b>ADA DETAILS WALNUT STREET NE QUADRANT</b>			F.A.P. RTE.	SECTION	COUNTY	TOTAL SHEETS	SHEET NO.
	PLOT SCALE = 10.0000' / 1"	DRAWN -	REVISED -		71	*	IROQUOIS	40	33			
	PLOT DATE = 12/15/2021	CHECKED -	REVISED -		CONTRACT NO. 66K77			ILLINOIS FED. AID PROJECT				
		DATE -	REVISED -		SCALE:	SHEET	OF	SHEETS	STA.	TO	STA.	







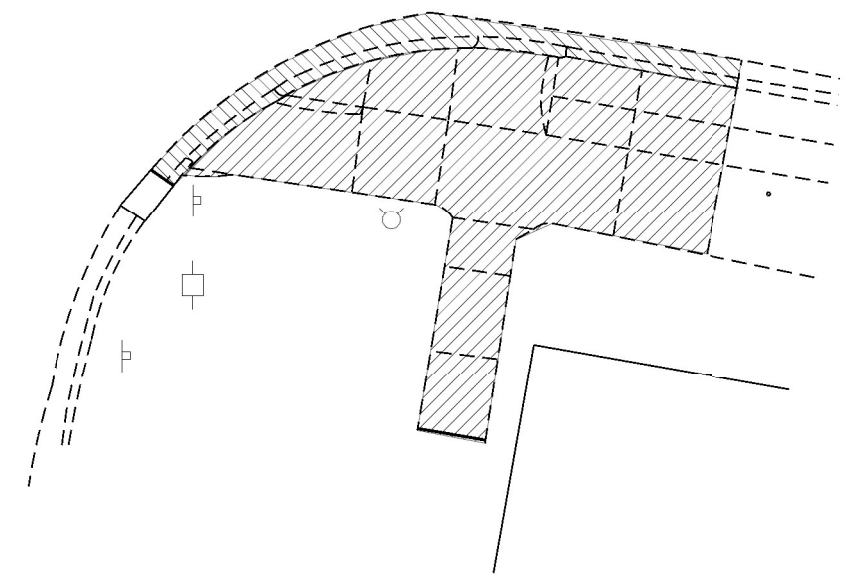
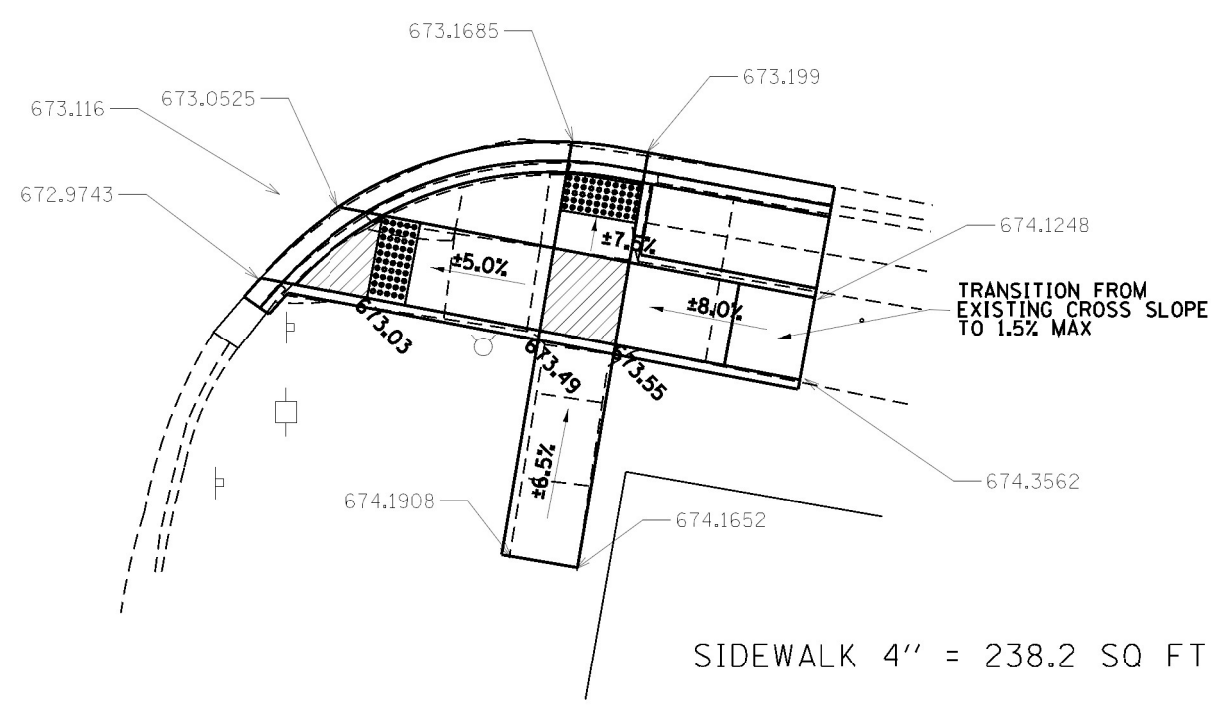

CCC & G = 34.0 FT

CURB REM = 34.0 FT



DETECTABLE WARNING =  
8.0 SQ FT + 8.0 SQ FT

SIDEWALK REM = 238.2 SQ FT

-  CURB AND GUTTER REMOVAL
-  SIDEWALK REMOVAL
-  PAVEMENT REMOVAL
-  DETECTABLE WARNING
-  TURNING SPACE / LEVEL LANDING  
15% CROSS-SLOPE BOTH DIRECTION
-  SODDING AREA  
INCLUDED IN SW WORK

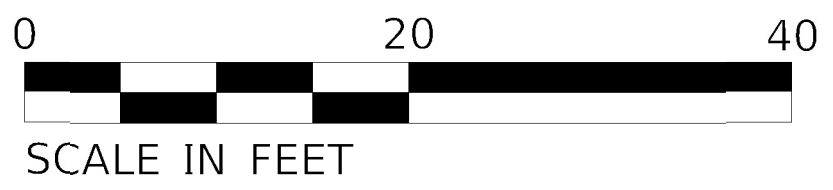

NOTES:

1. SEE HIGHWAY STANDARDS 424001 - 424031 FOR MAX SLOPES AND ADDITIONAL REQUIREMENTS.
2. SEE HIGHWAY STANDARD 606001 FOR CURB AND GUTTER REQUIREMENTS NEXT TO ADA RAMP.
3. ALL CROSS-SLOPES IN THE DIRECTION OF TRAVEL ARE AN ABSOLUTE MAXIMUM OF 2% LAYOUT SHOULD BE AT 1.5% TO ALLOW FOR ERROR WHILE REMAINING WITH THE MAXIMUM SLOPE.
4. SIDEWALK CURBS ARE SHOW ONLY AS REQUIRED BY FIELD CONDITIONS AND MAY BE OMITTED IF FOUND TO BE UNNECESSARY.
5. PEDESTRIAN PUSH BUTTON SIGN PAY ITEM TO BE INCIDENTAL TO THE PDESTRIAN PUSH BUTTON PAY ITEM.

MODEL: Default  
 FILE: Model - p:\miller\paw\_bentley.com\PROJECTS\66K77\CADD\DATA\CADD\Sheet\0366K77\_Proj\_ADA\_Plan.dgn

\* (112 & 112Z) & (38-5HB-4)RS-3.5W

USER NAME = plietschr DESIGNED - DRAWN - PLOT SCALE = 10.0000" / 1' PLOT DATE = 12/15/2021	DESIGNED - DRAWN - CHECKED - DATE -	REVISED - REVISED - REVISED - REVISED -	<b>STATE OF ILLINOIS</b> <b>DEPARTMENT OF TRANSPORTATION</b>	<b>ADA DETAILS</b> <b>WALNUT STREET SE QUADRANT</b>				F.A.P. RTE.	SECTION	COUNTY	TOTAL SHEETS	SHEET NO.
				71	*	IROQUOIS	40	34				
				SCALE:	SHEET	OF	SHEETS	STA.	TO	STA.	ILLINOIS FED. AID PROJECT	

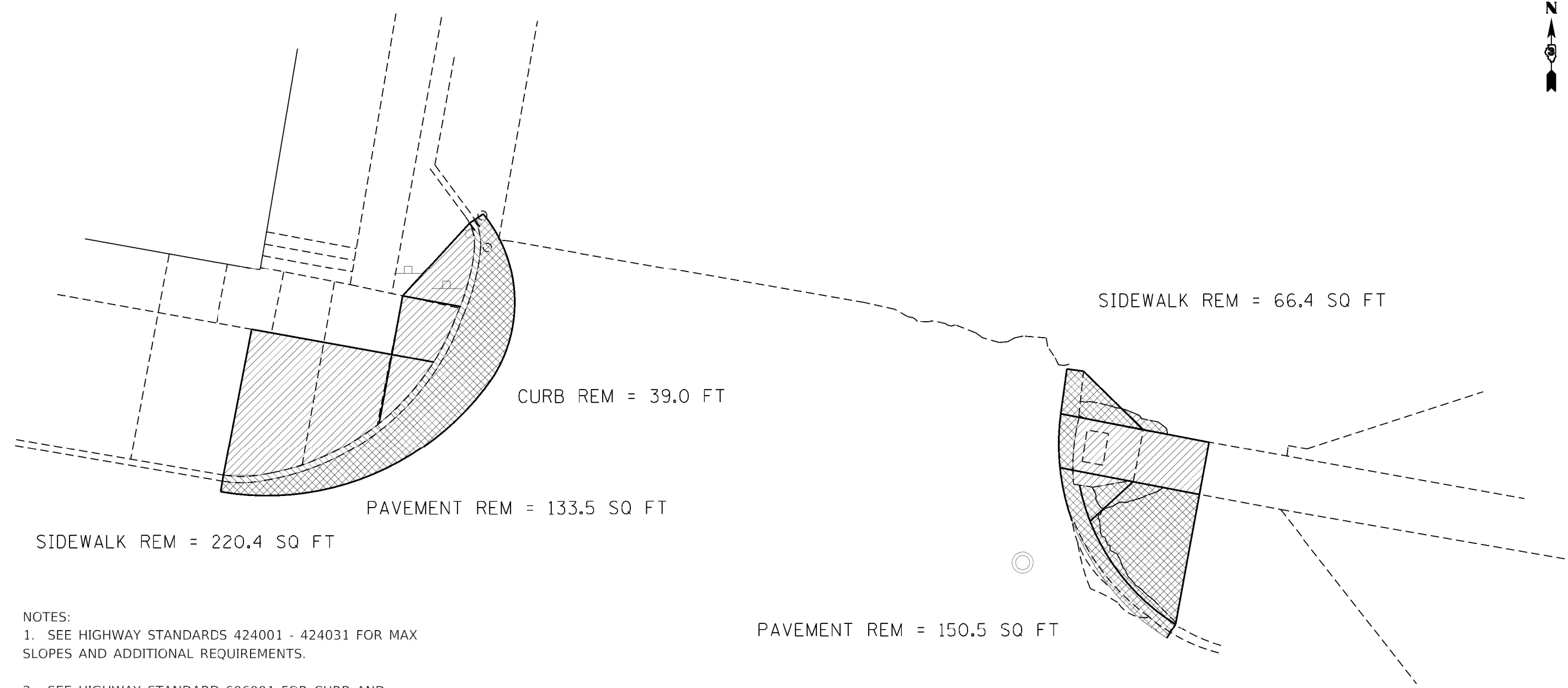

- NOTES:
1. SEE HIGHWAY STANDARDS 424001 - 424031 FOR MAX SLOPES AND ADDITIONAL REQUIREMENTS.
  2. SEE HIGHWAY STANDARD 606001 FOR CURB AND GUTTER REQUIREMENTS NEXT TO ADA RAMPS.
  3. ALL CROSS-SLOPES IN THE DIRECTION OF TRAVEL ARE AN ABSOLUTE MAXIMUM OF 2% LAYOUT SHOULD BE AT 1.5% TO ALLOW FOR ERROR WHILE REMAINING WITH THE MAXIMUM SLOPE.
  4. SIDEWALK CURBS ARE SHOW ONLY AS REQUIRED BY FIELD CONDITIONS AND MAY BE OMITTED IF FOUND TO BE UNNECESSARY.
  5. PEDESTRIAN PUSH BUTTON SIGN PAY ITEM TO BE INCIDENTAL TO THE PDESTRIAN PUSH BUTTON PAY ITEM.

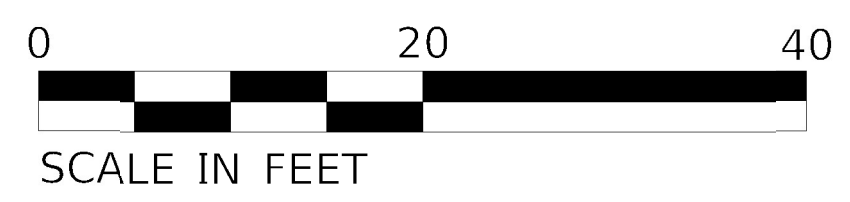

- CURB AND GUTTER REMOVAL
- SIDEWALK REMOVAL
- PAVEMENT REMOVAL

MODEL: Default  
 FILE: \\miller-pw-bentley.com\PWD\DOT\Documents\DOT\_Offices\District\_3\Project\10366427\10366427\10366427\_Proj\_ADA\_Plan.dgn

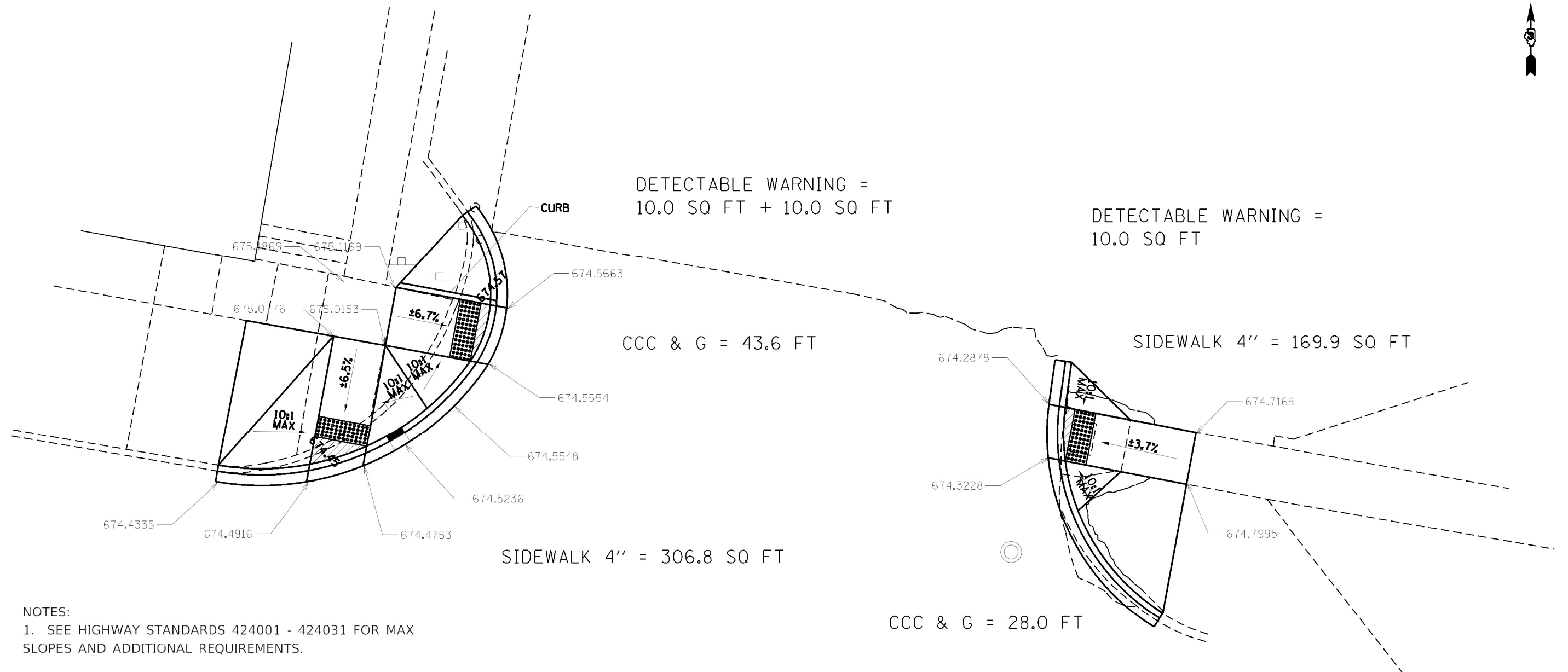

\*(112 & 112Z) & (38-5HB-4)RS-3.5W

	USER NAME = plietschr	DESIGNED -	REVISED -	<b>STATE OF ILLINOIS DEPARTMENT OF TRANSPORTATION</b>	<b>ADA DETAILS CHESTNUT STREET NW &amp; NE QUADRANTS</b>				F.A.P. RTE.	SECTION	COUNTY	TOTAL SHEETS	SHEET NO.
	PLOT SCALE = 10.0000" / 1'	CHECKED -	REVISED -		71	*	IROQUOIS	40	35				
	PLOT DATE = 12/15/2021	DATE -	REVISED -		SCALE:	SHEET	OF	SHEETS	STA.	TO	STA.	ILLINOIS FED. AID PROJECT CONTRACT NO. 66K77	



**NOTES:**

1. SEE HIGHWAY STANDARDS 424001 - 424031 FOR MAX SLOPES AND ADDITIONAL REQUIREMENTS.
2. SEE HIGHWAY STANDARD 606001 FOR CURB AND GUTTER REQUIREMENTS NEXT TO ADA RAMP.
3. ALL CROSS-SLOPES IN THE DIRECTION OF TRAVEL ARE AN ABSOLUTE MAXIMUM OF 2% LAYOUT SHOULD BE AT 1.5% TO ALLOW FOR ERROR WHILE REMAINING WITH THE MAXIMUM SLOPE.
4. SIDEWALK CURBS ARE SHOW ONLY AS REQUIRED BY FIELD CONDITIONS AND MAY BE OMITTED IF FOUND TO BE UNNECESSARY.
5. PEDESTRIAN PUSH BUTTON SIGN PAY ITEM TO BE INCIDENTAL TO THE PDESTRIAN PUSH BUTTON PAY ITEM.

-  DETECTABLE WARNING
-  TURNING SPACE / LEVEL LANDING  
15% CROSS-SLOPE BOTH DIRECTION
-  SODDING AREA INCLUDED IN SW WORK

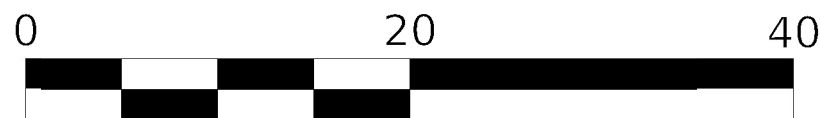

SCALE IN FEET

MODEL: Default  
 FILE: \\miller-pw-bentley.com\PWD\DOT\Documents\DOT\_Offices\Director\_3\Project\10366427\CADD\Info\CAD\Sheet\10366427\_Proj\_ADA\_Plan.dgn

\*( 112 & 112Z ) & ( 38-5HB-4 ) RS-3.5W

USER NAME = plietschr DRAWN - PLOT SCALE = 10.0000" / 1' PLOT DATE = 12/15/2021	DESIGNED - CHECKED - DATE -	REVISED - REVISED - REVISED - REVISED -	<b>STATE OF ILLINOIS</b> <b>DEPARTMENT OF TRANSPORTATION</b>	<b>ADA DETAILS</b> <b>CHESTNUT STREET NW &amp; NE QUADRANTS</b>				F.A.P. RTE.	SECTION	COUNTY	TOTAL SHEETS	SHEET NO.
				71	*	IROQUOIS	40	36				
SCALE: SHEET OF SHEETS STA. TO STA.										ILLINOIS FED. AID PROJECT CONTRACT NO. 66K77		

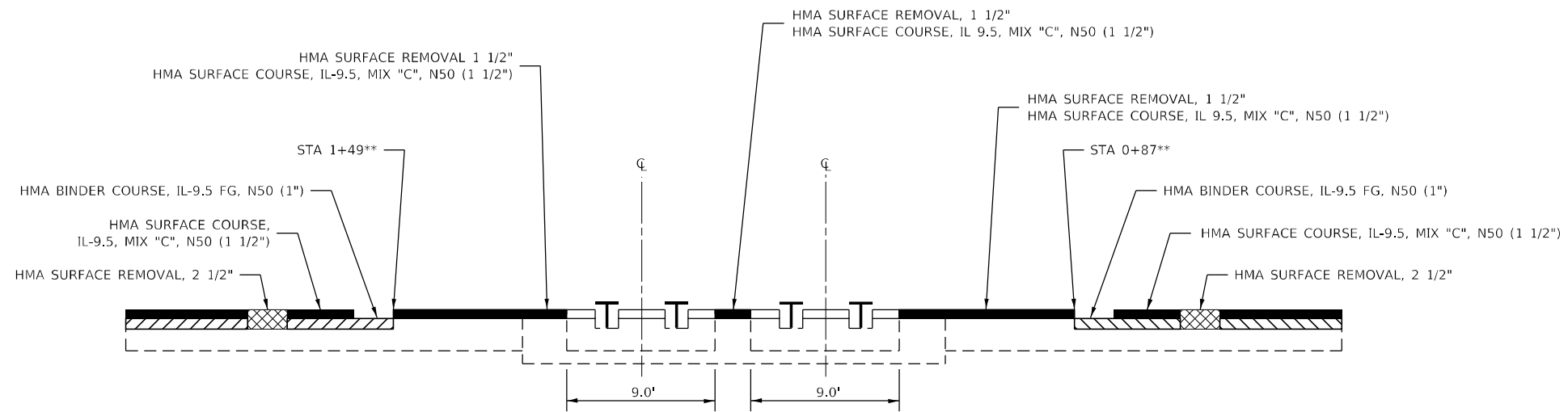

**MILLING DETAIL AT ILLINOIS CENTRAL RR CROSSING\*  
IL 54 /SEMINARY AVE.**

\* DETAILS ARE NOT TO SCALE

\*\* BUTT JOINT TO BE MINIMUM 20' FROM THE OUTSIDE EDGE OF RAILS.

\* FAS 323 / FAP 71  
\*\* (112&112Z)&(38-5HB-4)RS-3,SW

FILE NAME =	USER NAME = pletschr	DESIGNED - _____	REVISED - _____
pw:\idot-pw\berkeley.com\PWIDOT\Documents\IDOT Office\District 3\Projects\I366K77\CADData\CADSheets\I366K77-4		DRAWN - _____	REVISED - _____
Default	PLOT SCALE = 100,0000' / in.	CHECKED - _____	REVISED - _____
	PLOT DATE = 12/15/2021	DATE - _____	REVISED - _____

**STATE OF ILLINOIS  
DEPARTMENT OF TRANSPORTATION**

**DETAILS**

SCALE: \_\_\_\_\_ SHEET \_\_\_\_\_ OF \_\_\_\_\_ SHEETS STA. \_\_\_\_\_ TO STA. \_\_\_\_\_

F.A. RTE.	SECTION	COUNTY	TOTAL SHEETS	SHEET NO.
*	**	IROQUOIS	40	37
CONTRACT NO. 66K77				
ILLINOIS FED. AID PROJECT				

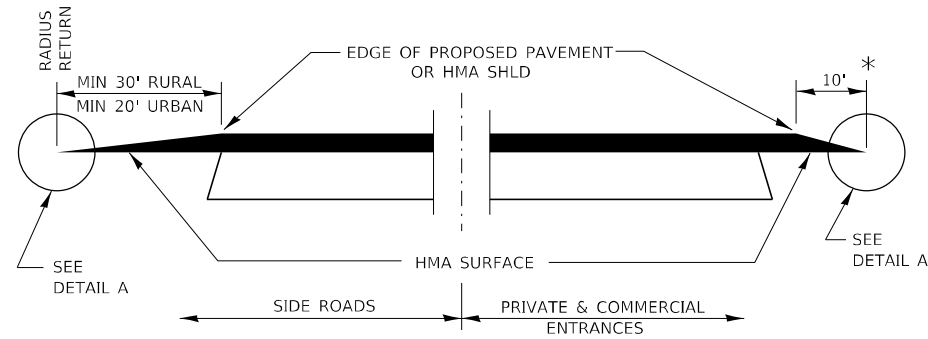

**SECTION A-A**  
**DETAILS AT ENTRANCES & SIDE ROADS**

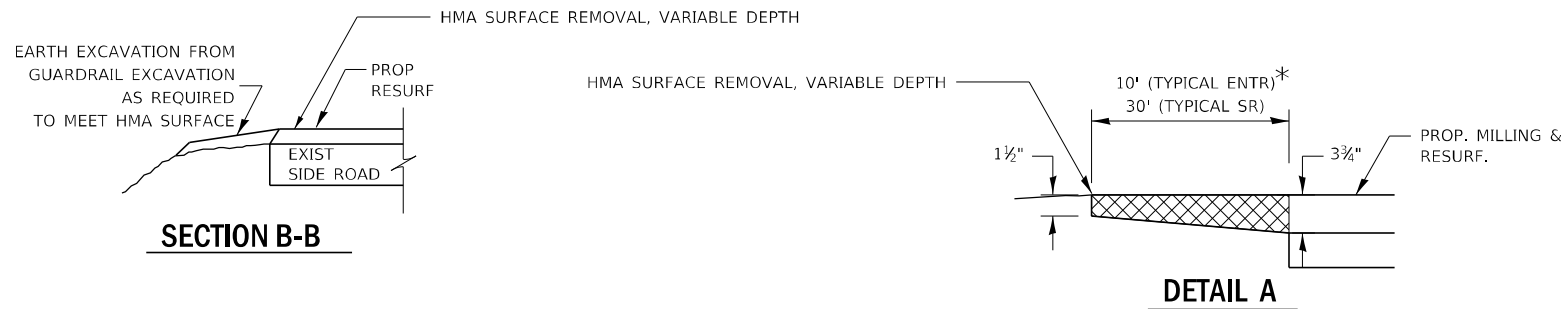

**SECTION B-B**

**DETAIL A**

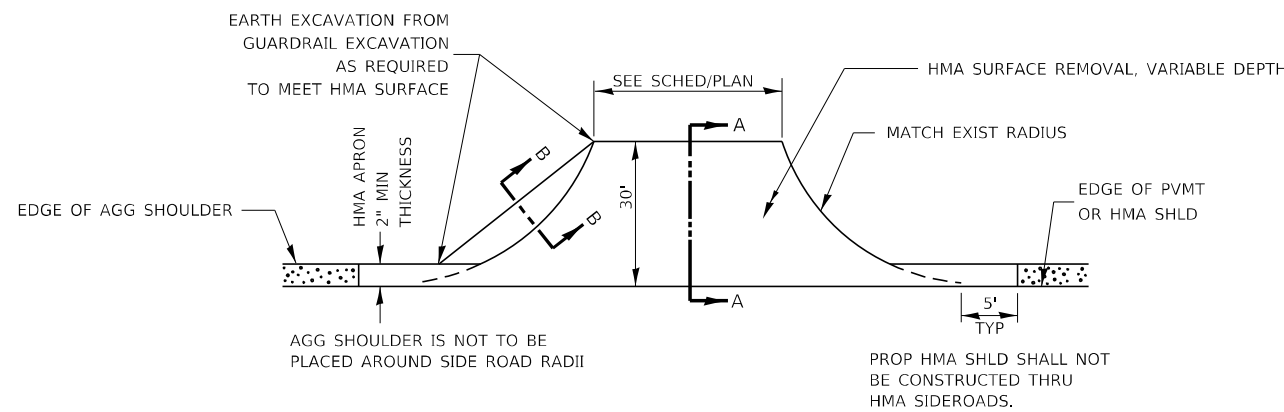

**PLAN AT SIDE ROADS**

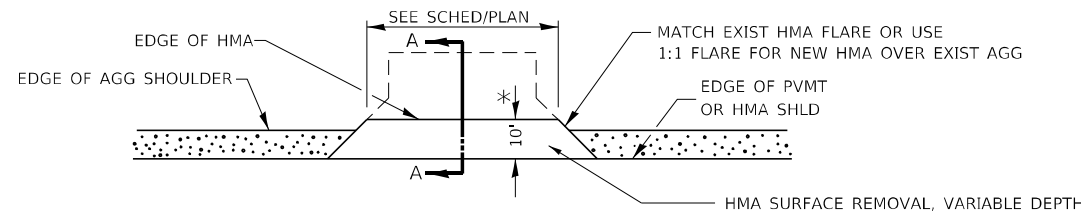

**PLAN AT PRIVATE & COMMERCIAL ENTRANCES**

(DO NOT RESURFACE FIELD ENTRANCES)

\* PROPOSED HMA RESURFACING AT PUBLIC EDUCATIONAL FACILITY ENTRANCES SHALL BE EXTENDED TO THE RIGHT-OF-WAY LIMITS.

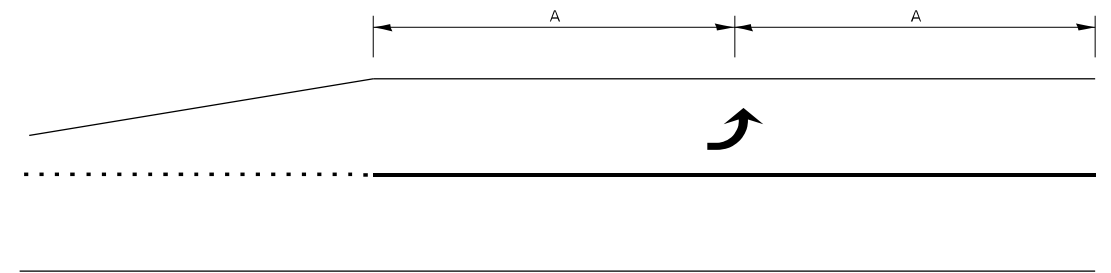

**99' AND UNDER**

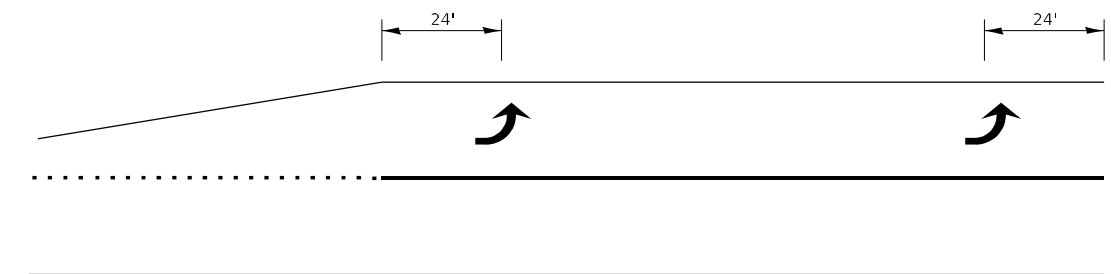

**100' TO 149'**

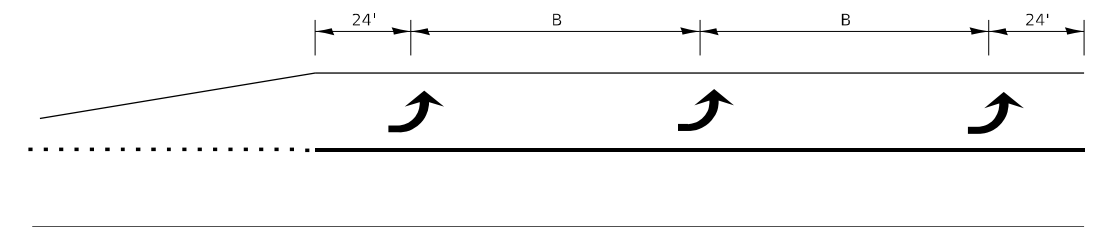

**150' AND LONGER**

**TYPICAL PLACEMENT OF ARROWS IN TURN LANES**

FILE NAME =	USER NAME = pletschr	DESIGNED -	REVISED -
pw:\idot\pw\berkeley.com\PWIDOT\Documents\IDOT Office\District 3\Projects\I366K77\CADData\CADSheets\I366K77-4		DRAWN -	REVISED -
Default	PLOT SCALE = 100,0000' / in.	CHECKED -	REVISED -
	PLOT DATE = 12/15/2021	DATE -	REVISED -

**STATE OF ILLINOIS**  
**DEPARTMENT OF TRANSPORTATION**

<b>DETAILS</b>	
SCALE: _____	SHEET _____ OF _____ SHEETS
STA. _____	TO STA. _____

F.A.* RTE.	SECTION	COUNTY	TOTAL SHEETS	SHEET NO.
-	**	IROQUOIS	40	38
CONTRACT NO. 66K77				
ILLINOIS FED. AID PROJECT				

\* FAS 323 / FAP 71  
\*\* (112&112Z)&(38-5HB-4)RS-3,SW



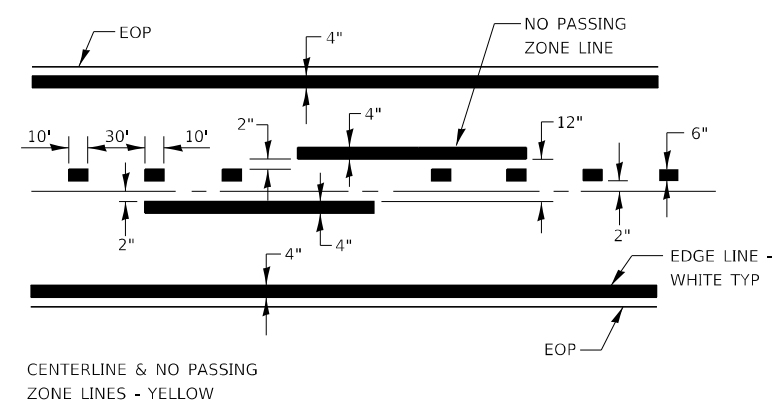

**PAVEMENT MARKING**

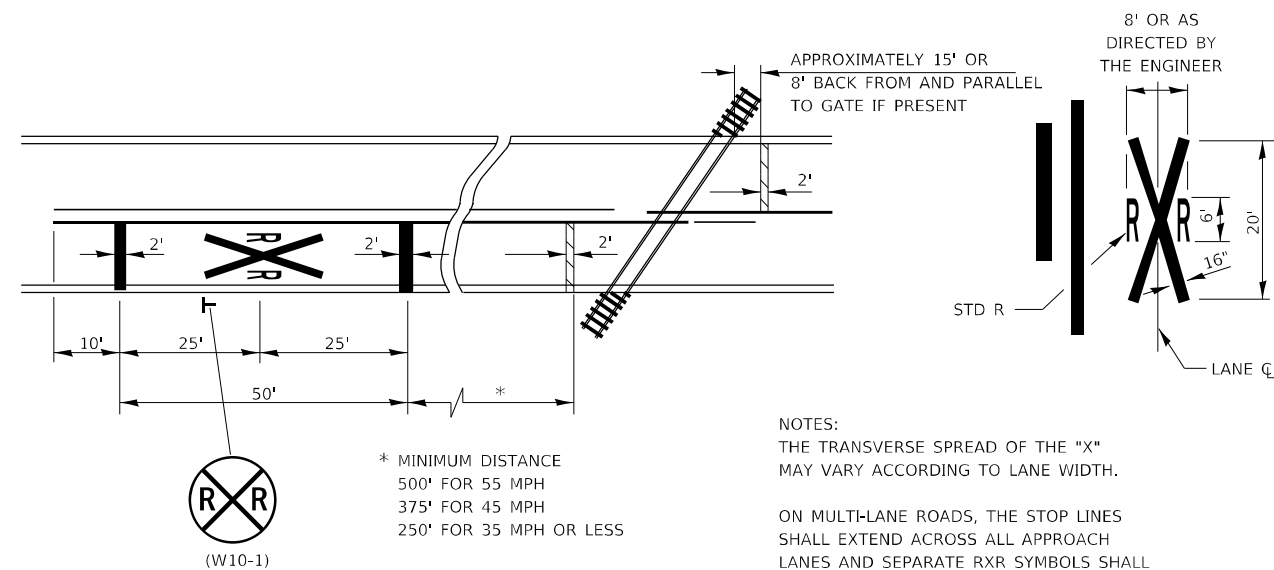

**PAVEMENT MARKINGS AT RAILROAD-HIGHWAY GRADE CROSSING**

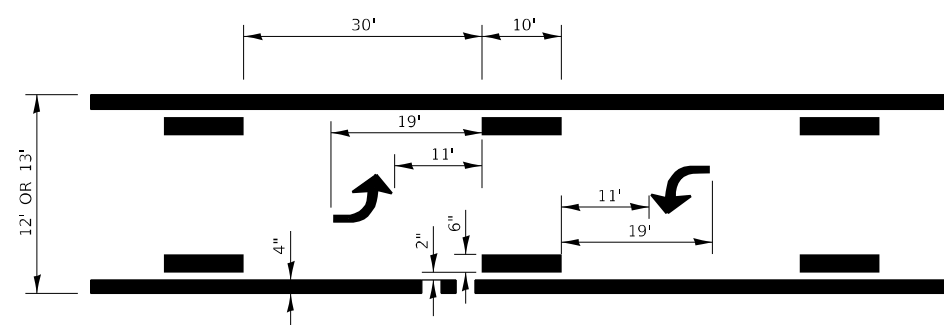

**TYPICAL APPLICATION @ BI-DIRECTIONAL TURN LANE**

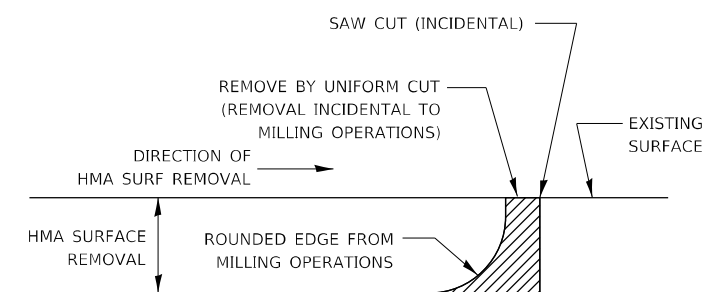

**NOTE:**  
WHEN MILLING OPERATIONS PRODUCE A ROUNDED EDGE, THEN A SAW CUT SHALL BE USED TO MANUFACTURE A PERPENDICULAR EDGE AS SHOWN IN THE DETAIL. THE ENGINEER SHALL BE THE SOLE JUDGE CONCERNING THE USE OF THIS DETAIL

**HMA DETAIL AT BUTT JOINTS**

MODEL: Default  
FILE: hma.dwg  
PROJECT: p:\public\paw.bentley.com\p\illinois\Documents\DOT Office\Drawings\Project\31\Project\10366677\10366677\10366677-dwg-details.dgn

USER NAME = pletschtr	DESIGNED - _____	REVISED - _____
DRAWN - _____	REVISIONS - _____	
PLOT SCALE = 100,0000' / in.	CHECKED - _____	REVISIONS - _____
PLOT DATE = 12/15/2021	DATE - _____	REVISIONS - _____

**STATE OF ILLINOIS  
DEPARTMENT OF TRANSPORTATION**

SCALE: \_\_\_\_\_ SHEET \_\_\_ OF \_\_\_ SHEETS STA. \_\_\_\_\_ TO STA. \_\_\_\_\_

* FAS 323 / FAP 71 ** (112&112Z)&(38-5H-4)RS-3,SW					
F.A.* RTE.	SECTION	COUNTY	TOTAL SHEETS	SHEET NO.	
**	**	IROQUOIS	40	39	
CONTRACT NO. 66K77					
			ILLINOIS FED. AID PROJECT		

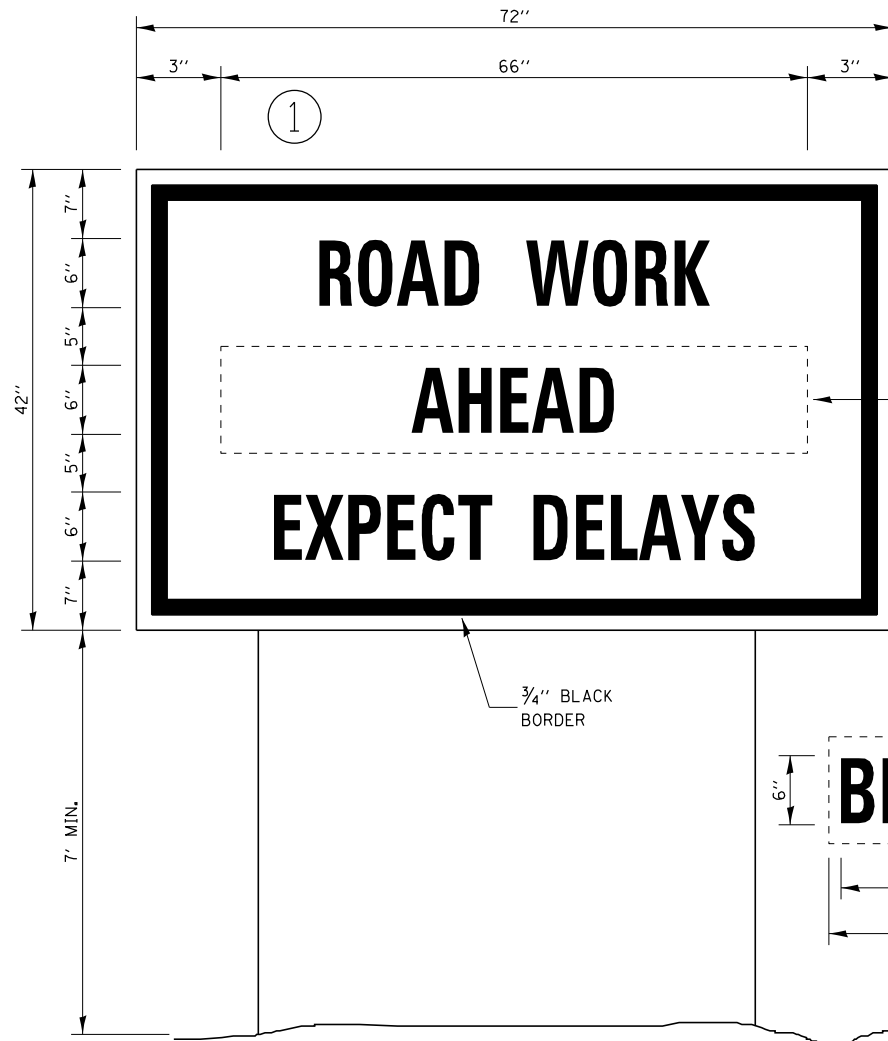

**TEMPORARY INFORMATION SIGNING**

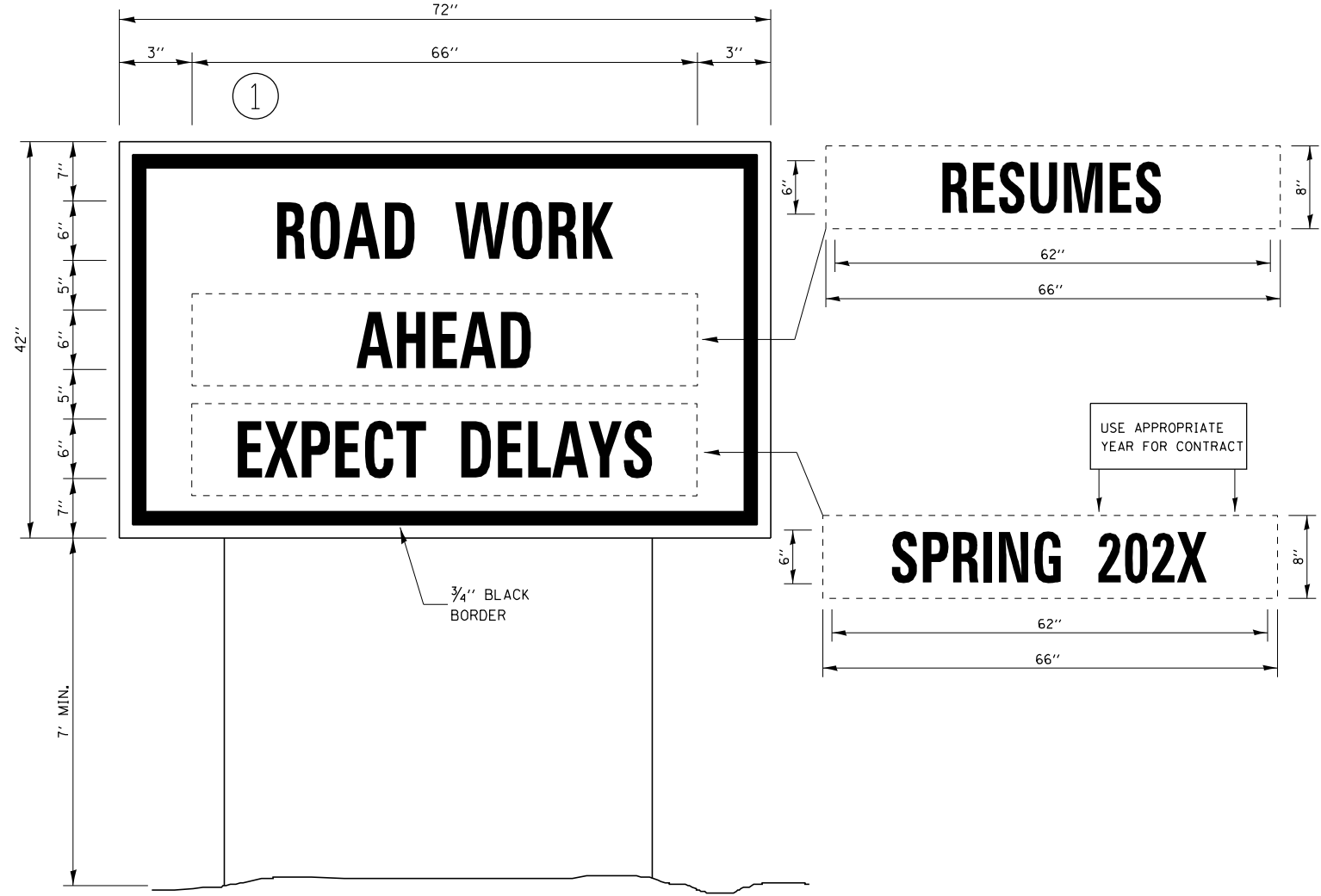

**WINTER CLOSURE SIGNING**

**NOTES:**

1. USE 6" D BLACK LETTERING ON FLOURESENT ORANGE BACKGROUND.
2. ERECT SIGNS AT LOCATIONS IN ADVANCE OF THE "ROAD CONSTRUCTION AHEAD" SIGNS AS DIRECTED BY THE ENGINEER.
3. ERECT SIGN ① WITH INSTALLED PANEL ② A MINIMUM OF ONE WEEK PRIOR TO THE START OF THE LANE CLOSURE.
4. REMOVE PANEL ② ON THAT DATE.
5. SEE SPECIAL PROVISION "TEMPORARY INFORMATION SIGNING" FOR ADDITIONAL INFORMATION.
6. WILL BE PAID FOR PER SQ FT AS "TEMPORARY INFORMATION SIGNING". EACH SIGN = 21 SQ FT AND THE DATE PANEL ② WILL NOT BE MEASURED SEPARATELY FOR PAYMENT.

MODEL: Default  
 FILE: \\na11c:\pub\subject-pw\benefit\com\PI\INDOT\Documents\1\DOT\Office\Dir\drct\_3\Project\1\366677\CADD\data\CAD\Sheet\366677-4-1b-detailed.dgn

\* FAS 323 / FAP 71  
 \*\* (112&112Z)&(38-5HB-4)RS-3,SW

USER NAME = pletschr	DESIGNED - _____	REVISED - _____
PLOT SCALE = 100,0000' / in.	DRAWN - _____	REVISED - _____
PLOT DATE = 12/15/2021	CHECKED - _____	REVISED - _____
	DATE - _____	REVISED - _____

**STATE OF ILLINOIS  
 DEPARTMENT OF TRANSPORTATION**

**DETAILS**

SCALE: \_\_\_\_\_ SHEET \_\_\_\_\_ OF \_\_\_\_\_ SHEETS STA. \_\_\_\_\_ TO STA. \_\_\_\_\_

F.A.* RTE.	SECTION	COUNTY	TOTAL SHEETS	SHEET NO.
*	**	IROQUOIS	40	40
CONTRACT NO. 66K77				
ILLINOIS FED. AID PROJECT				