

STATE OF ILLINOIS
DEPARTMENT OF TRANSPORTATION

ROUTE NO.	SECTION	COUNTY	TOTAL SHEETS	SHEET NO.
F.A.I-72	58-63HVB	MACON	57	55
FED. ROAD DIST. NO. 7	ILLINOIS	FED. AID PROJECT		

SHEET NO. 16
26 SHEETS

9B

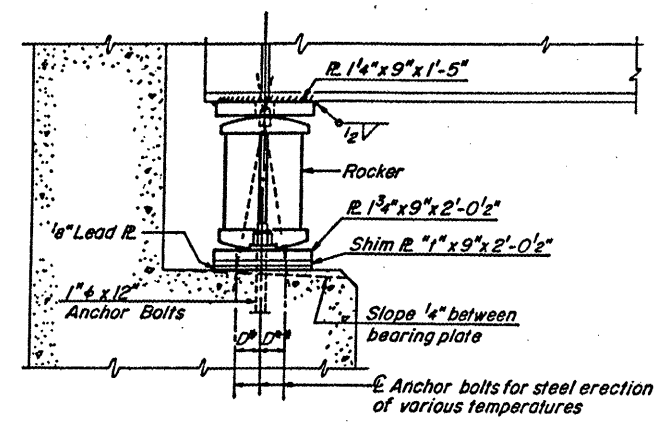

ELEVATION SOUTH ABUT.

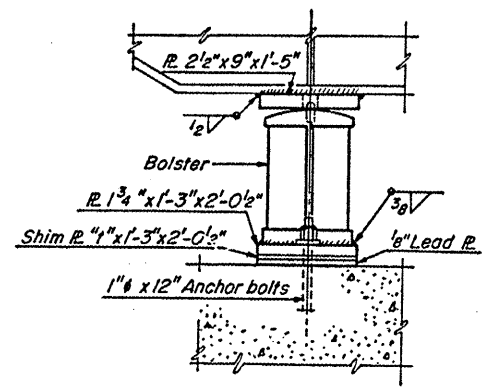

ELEVATION PIER #1

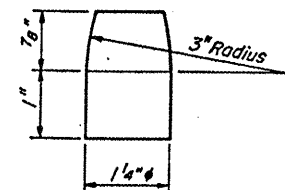

PINTLE

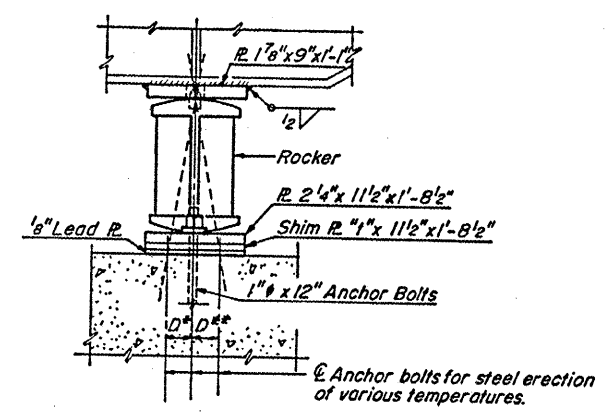

ELEVATION PIER #2

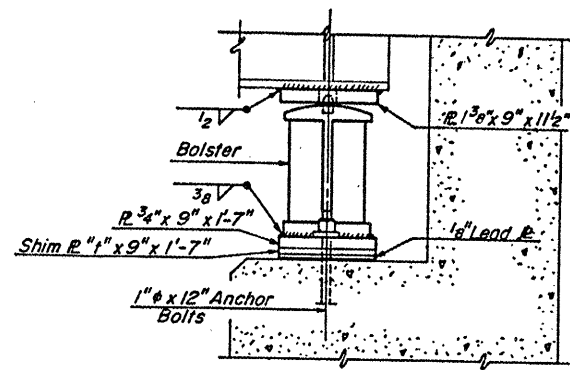

ELEVATION NORTH ABUT.

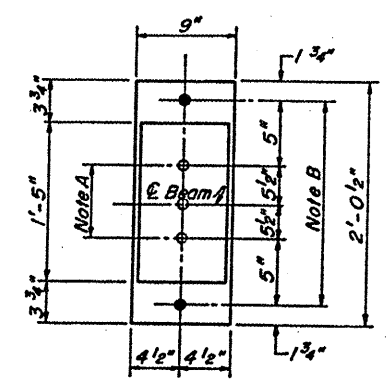

PLAN

NOTE A
1 3/8" ϕ Holes - 1" deep in top R for pintles. Thread or press fit pintles into bottom R.

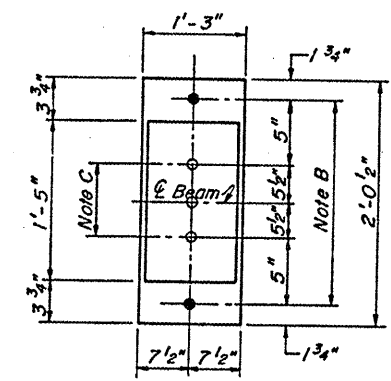

PLAN

NOTE B
1 1/2" ϕ Holes for 1" ϕ anchor bolts. 5/16" x 2 1/2" x 2 1/2" R Washers under nut.

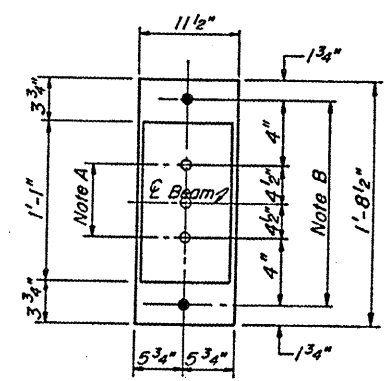

PLAN

NOTE C
1 3/8" ϕ Holes 1" deep in top R only for 1 1/4" ϕ pintles.

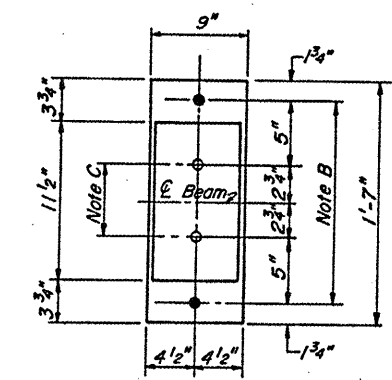

PLAN

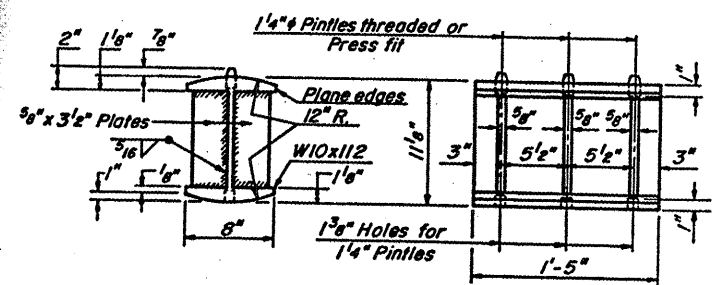

ROCKER SOUTH ABUT.

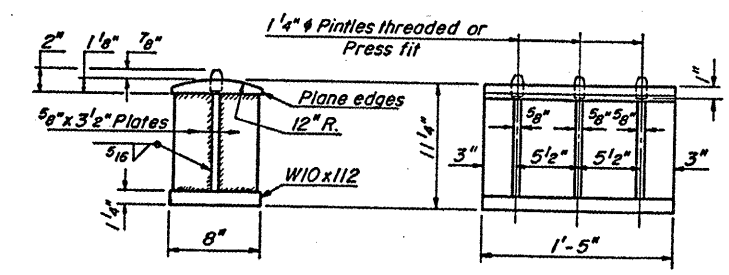

BOLSTER PIER #1

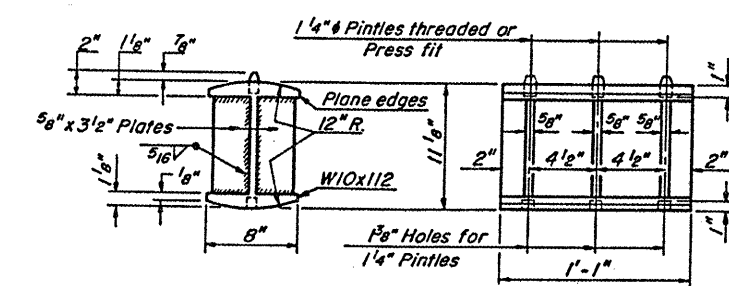

ROCKER PIER #2

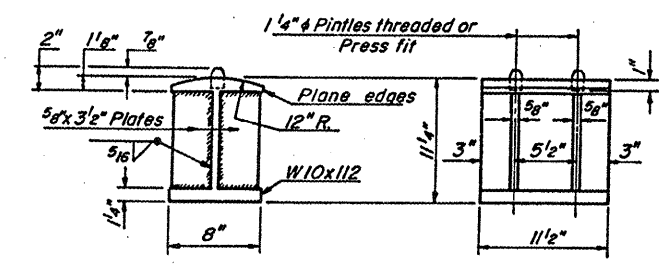

BOLSTER NORTH ABUT.

DESIGNED	D.V.K.
CHECKED	G.E.P.
DRAWN	R.H.H.
CHECKED	G.E.P.

NOTE: Bearing seat surfaces shall be constructed or adjusted to the designed elevations within a tolerance of $\pm 1/8$ ". Adjustment shall be made either by grinding the surface or by shimming the bearing. Two 1/8" adjust shims, of the dimensions of the bottom bearing plate, shall be provided for each bearing in addition to all other plates or shims.

NOTES ON SETTING OF ANCHOR BOLTS AT EXP. BRGS.

- (a) D* (Side of brg. away from fixed brg.) = 1/8" per each 100' of expansion for every 15° fall below the normal temp. of 50° F. D** (Side of brg. toward fixed brg.) = 1/8" per each 100' of expansion for every 15° rise above the normal temp. of 50° F.
- (b) After beams have been erected and dimensions D* or D** determined, holes shall be drilled and anchor bolts shall be grouted in place. All fixed anchor bolts may be built into the masonry.

Location	Su. Abut.	Pier 1	Pier 2	No. Abut.
Gdr. 2		5/8"		
7	5/8"	5/8"		
15	3/8"	1/2"	1/2"	3/8"
19			5/8"	

Provide Shim Plates of the same dimensions of the bottom bearing plate and thickness shown. See Shim Table.

BEARING DETAILS
F.A.I-72 over ILL. RTE. 121
& ILL. CENT-GULF R.R.
MACON COUNTY
SEC. 58-63HVB
STA. 724+45.63