

F.A.I.	SECTION	COUNTY	TOTAL SHEETS	SHEET NO.
57	1919.2B	COOK	119	1
FED. ROAD DIST. NO.		ILLINOIS	FED. AID PROJECT	
D-91-276-97		CONTRACT 60371		

FOR INDEX OF SHEETS, SEE SHEET NO. 2

PROJECT LOCATED IN CITY OF CHICAGO

**TRAFFIC DATA**

115th STREET WEST OF MARSHFIELD

ADT = 8,100 (1994) 9,123 (2008) 10,000 (2020)

115th STREET ACROSS BRIDGE

ADT = 9,700 (1994) 10,938 (2008) 12,000 (2020)

115th STREET EAST OF ASHLAND

ADT = 11,000 (1994) 12,077 (2008) 13,000 (2020)

TRUCK PERCENTAGE = 5.0 %

F.A.I. 57

ADT = 114,500 (1996) BRIDGE

**POSTED SPEED LIMITS:**

115th STREET = 50KPH (30MPH)

I-57 = 90KPH (55MPH)

**DESIGN DESIGNATION**

1200 (20) COLLECTOR URBAN

1.27 (COMPOSITE - 20)

**DESCRIPTION OF IMPROVEMENT**

THE BRIDGE WORK CONSISTS OF REMOVAL AND REPLACEMENT OF THE EXISTING DECK.

THE ROADWAY WORK CONSISTS OF PAVEMENT WIDENING AND RESURFACING, STORM SEWER MODIFICATION, TRAFFIC SIGNAL MODERNIZATION AND PAVEMENT MARKING.

**METRIC RATIOS**

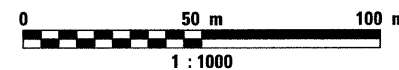
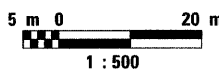
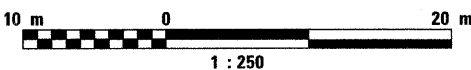
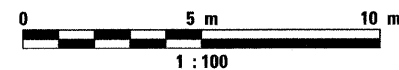
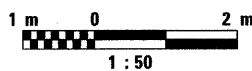

FULL SIZE PLANS HAVE BEEN PREPARED USING STANDARD ENGINEERING SCALES. REDUCED SIZED PLANS WILL NOT CONFORM TO STANDARD SCALES. IN MAKING MEASUREMENTS ON REDUCED PLANS, THE ABOVE SCALES MAY BE USED.

FOR UTILITY INFORMATION CONTACT CHICAGO UTILITY ALERT NETWORK AT 312-744-7000

CONTRACT NO. 60371

STATE OF ILLINOIS  
DEPARTMENT OF TRANSPORTATION  
DIVISION OF HIGHWAYS

**PROPOSED  
HIGHWAY PLANS**

FAI 57 OVER 115th STREET  
BRIDGE DECK REPLACEMENT  
SECTION 1919.2B  
PROJECT: ESP-057-7(280)356  
COOK COUNTY  
C-91-276-97



LOCATION MAP SCALE

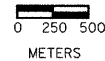

PROJECT BEGINS  
STATION 2+261.000  
115th STREET

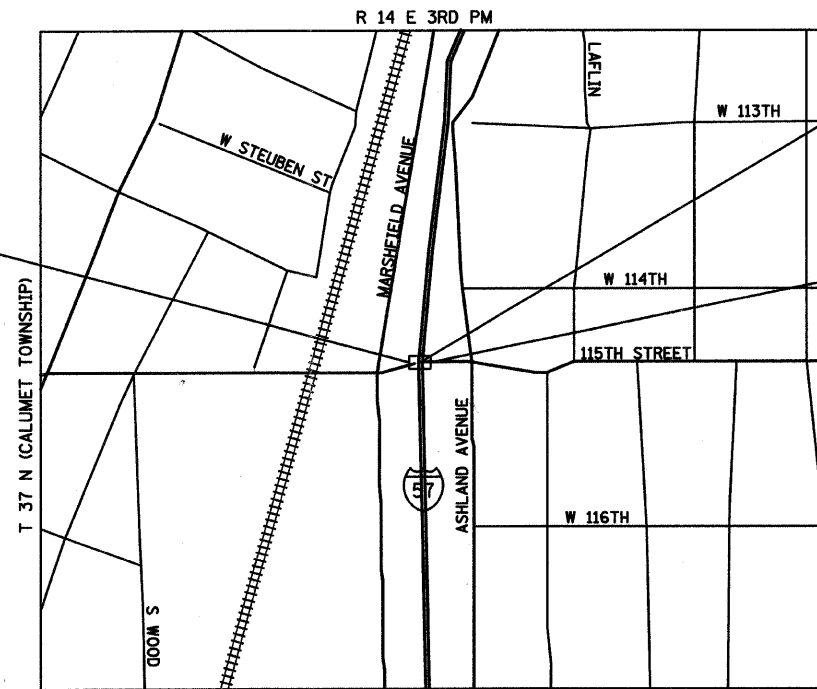

STATION 2+382.915  
S.N. 016-2037  
115th STREET OVER  
F.A.I. 57  
57.022 m BK-BK OF ABUTMENTS  
THE BRIDGE WORK CONSISTS OF REMOVAL  
AND REPLACEMENT OF THE EXISTING DECK.

PROJECT ENDS  
STATION 2+538.812  
115th STREET

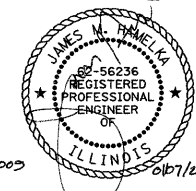
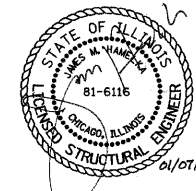

COLLINS ENGINEERS, INC.  
JAMES M. HAMELKA, S.E., P.E.  
NO. 81-6116 (S.E.)  
EXP.: 11/30/2010 (S.E.)  
NO. 62-56236 (P.E.)  
EXP.: 11/30/2011 (P.E.)

STATE OF ILLINOIS  
DEPARTMENT OF TRANSPORTATION  
DIVISION OF HIGHWAYS

SUBMITTED: JANUARY 12, 20 09

*Diana M. O'Neil* or  
DEPUTY DIRECTOR OF HIGHWAYS, REGION ENGINEER

March 13, 20 09  
*Charles G. Ingerson*  
ENGINEER OF DESIGN AND ENVIRONMENT

March 13, 20 09  
*Christine M. Reed*  
DIRECTOR OF HIGHWAYS, CHIEF ENGINEER

PRINTED BY THE AUTHORITY  
OF THE STATE OF ILLINOIS

COLLINS ENGINEERS, INC.  
123 North Wacker Drive  
Suite 300  
Chicago, IL 60606  
(312) 704-9300  
www.collinseng.com  
ILLINOIS PROFESSIONAL DESIGN FIRM LICENSE NO. 184-00093

IDOT DESIGN-CONSULTANT PROJECT MANAGER - MR. BRIAN KUTTAB, P.E. - (847)705-4431  
 FILE: g:\2904\civil\exhib\11\2904001.dgn  
 DATE: 19-Aug-08 14:24

F.A.I.	SECTION	COUNTY	TOTAL SHEETS	SHEET NO.
57	1919.2B	COOK	119	2
FED. ROAD DIST. NO.		ILLINOIS FED. AID PROJECT		

CONTRACT 60371

INDEX OF SHEETS

SHEET NO.	DESCRIPTION
1	TITLE SHEET
2	INDEX OF SHEETS AND CITY OF CHICAGO NOTES
3	STATE STANDARDS, GENERAL NOTES AND COMMITMENTS
4-8	SUMMARY OF QUANTITIES
9	TYPICAL SECTIONS
11	SCHEDULE OF QUANTITIES
17	ALIGNMENT, TIES AND BENCHMARKS
18	EXISTING ROADWAY AND EROSION CONTROL PLAN-115th STREET AND MARSHFIELD AVENUE
19	EXISTING ROADWAY AND EROSION CONTROL PLAN-115th STREET AND ASHLAND AVENUE
20	PROPOSED ROADWAY PLAN-115th STREET AND MARSHFIELD AVENUE
21	PROPOSED ROADWAY PLAN-115th STREET AND ASHLAND AVENUE
22	EXISTING AND PROPOSED ROADWAY PROFILE-115th STREET
23	SUGGESTED STAGES OF CONSTRUCTION AND TRAFFIC CONTROL TYPICAL SECTIONS
24	SUGGESTED STAGES OF CONSTRUCTION AND TRAFFIC CONTROL SHOULDER CLOSURE
25	SUGGESTED STAGES OF CONSTRUCTION AND TRAFFIC CONTROL STAGE I-A
26	SUGGESTED STAGES OF CONSTRUCTION AND TRAFFIC CONTROL STAGE I-B
27	SUGGESTED STAGES OF CONSTRUCTION AND TRAFFIC CONTROL STAGE I-A AND I-B
28	SUGGESTED STAGES OF CONSTRUCTION AND TRAFFIC CONTROL STAGE II-A
29	SUGGESTED STAGES OF CONSTRUCTION AND TRAFFIC CONTROL STAGE II-B
30	SUGGESTED STAGES OF CONSTRUCTION AND TRAFFIC CONTROL STAGE II-A AND II-B
31	SUGGESTED STAGES OF CONSTRUCTION AND TRAFFIC CONTROL STAGE III
32	SUGGESTED STAGES OF CONSTRUCTION AND TRAFFIC CONTROL STAGE III
33	EXISTING DRAINAGE AND UTILITY PLAN
34	PROPOSED DRAINAGE AND UTILITY PLAN
35	DRAINAGE SCHEDULE
36	PROPOSED INTERSECTION DETAIL PLAN-115th STREET AND MARSHFIELD AVENUE
37	PROPOSED INTERSECTION DETAIL PLAN-115th STREET AND ASHLAND AVENUE
38	ADA CURB RAMP DESIGN DETAILS
39	PAVEMENT MARKING AND LANDSCAPING PLAN
40	BRIDGE APPROACH PAVEMENT DETAILS I
41	BRIDGE APPROACH PAVEMENT DETAILS II
42	TRAFFIC SIGNAL AND LIGHTING PLANS
74-76	STRUCTURE PLANS
97	FRAMES AND LIDS ADJUSTMENT WITH MILLING AND FRAMES AND LIDS ADJUSTMENT WITHOUT MILLING, BD-8
98	CITY OF CHICAGO PC CONC. DRIVEWAY, ALLEY RETURN AND SIDEWALK, BD-17
99	PAVEMENT PATCHING FOR HMA SURFACED PAVEMENT, BD-22
100	CURB OR CURB AND GUTTER REMOVAL AND REPLACEMENT, BD-24
101	BUTT JOINTS AND HMA TAPER DETAILS, BD-32
102	HMA TAPER AT EDGE OF PCC PAVEMENT, BD-33
103	CITY OF CHICAGO CATCH BASINS, INLET AND MANHOLE DETAILS, BD-47
104	ENTRANCE AND EXIT RAMP CLOSURE DETAILS, TC-8
105	TRAFFIC CONTROL DETAILS FOR SINGLE LANE AND MULTI LANE WEAVE, TC-9
106	TRAFFIC CONTROL AND PROTECTION FOR SIDE ROADS, INTERSECTIONS AND DRIVEWAYS, TC-10
107	TRAFFIC CONTROL AND PROTECTION AT TURN BAYS (TO REMAIN OPEN TO TRAFFIC), TC-14
108	PAVEMENT MARKING LETTERS AND SYMBOLS FOR TRAFFIC STAGING, TC-16
109	TRAFFIC CONTROL FOR SHOULDER CLOSURES AND PARTIAL RAMP CLOSURES, TC-17
110	TEMPORARY INFORMATION SIGNING, TC-22
111	SIGNING AND PAVEMENT MARKINGS TREATMENT FOR RAILROAD CROSSING, TC-23
112	CITY OF CHICAGO TYPICAL PAVEMENT MARKINGS, TC-24 (SHEET 1 OF 2)
113	CITY OF CHICAGO TYPICAL PAVEMENT MARKINGS, TC-24 (SHEET 2 OF 2)
114-119	CROSS SECTIONS HIGHWAY STANDARDS

CITY OF CHICAGO- PLAN NOTES

ALL CATCH BASINS IN THE CITY OF CHICAGO MUST MEET THE DEPARTMENT OF SEWERS' STANDARDS.

SEWER SIZES 525 mm (21") DIAMETER OR SMALLER MUST BE EXTRA STRENGTH VITRIFIED CLAY PIPE C-700 OR DUCTILE IRON PIPE WITH PUSH-ON OR MECHANICAL JOINTS. SEWER SIZES 600 mm (24") DIAMETER OR LARGER MUST BE REINFORCED CONCRETE PIPE TYPE C-76, CLASS III, WALL "B" WITH "O-RING" JOINTS.

PERMITS FROM THE DEPARTMENT OF SEWERS ARE REQUIRED FOR ALL UNDERGROUND STORM, SANITARY OR COMBINED SEWER SYSTEM CONSTRUCTION AND FOR ALL WORK INVOLVING ADJUSTMENT OF SEWER STRUCTURES. THE DEPARTMENT OF SEWERS' PERMIT MUST BE OBTAINED BY A LICENSED SEWER DRAIN LAYER PRIOR TO START OF CONSTRUCTION. THE LICENSED SEWER CONTRACTOR/SUBCONTRACTOR MUST SUBMIT TWO SETS OF PLANS APPROVED BY THE DEPARTMENT OF SEWERS FOR THE ISSUE OF THE SEWER PERMIT TO SUITE 410, 333 SOUTH STATE STREET, CHICAGO, IL. 60604-3971. INSPECTION WILL BE PROVIDED BY THE DEPARTMENT OF SEWERS'.

IF THE SEWER PIPE COVER IS REDUCED TO LESS THAN 1 METER (3 FEET) CONCRETE ENCASEMENT OF THE SEWER OR REPLACEMENT OF THE SEWER WITH CLASS 52, DUCTILE IRON PIPE WILL BE REQUIRED.

IN CASE OF DAMAGE TO CITY OF CHICAGO SEWERS, PRIVATE AND PUBLIC DRAINS, SEWER STRUCTURES AND/OR BENCH MONUMENTS, THE CONTRACTOR SHALL IMMEDIATELY CONTACT THE DEPARTMENT OF SEWERS AT (312) 747-7892 OR (312) 747-7893.

CITY OF CHICAGO- PLAN NOTES (CONTINUED)

PERFORATED LIDS SHALL BE PLACED ON ALL MANHOLES AND CATCH BASINS.

BENCH MONUMENT LOCATIONS WITHIN THE LIMITS OF THE IMPROVEMENTS CAN BE OBTAINED FROM THE DEPARTMENT OF SEWERS AT SUITE 410, 333 SOUTH STATE STREET, CHICAGO, IL. 60604-3971. THE CONTRACTOR IS RESPONSIBLE FOR THE COST OF REPLACING ANY BENCH MONUMENT DAMAGED OR DESTROYED DURING CONSTRUCTION.

SIDEWALK ACCESSIBILITY RAMPS SHALL NOT BE CONSTRUCTED DIRECTLY OVER EXISTING OR PROPOSED DRAINAGE STRUCTURES.

ALL BROKEN, CRACKED, WORN OR OTHERWISE DAMAGED OR BICYCLE UNSAFE FRAMES AND GRATES OR LIDS ON SEWER STRUCTURES SHALL BE REPLACED WITH NEW DEPARTMENT OF SEWERS' STANDARD FRAMES AND GRATES OR LIDS. OLD FRAMES AND GRATES OR LIDS SHALL BE DELIVERED TO THE DEPARTMENT OF SEWERS AT 39TH STREET AND ASHLAND AVENUE.

CITY OF CHICAGO WATER VALVE VAULTS AND SEWER STRUCTURES SHALL NOT BE CLOSED, COVERED OR OTHERWISE OBSTRUCTED DURING CONSTRUCTION WITHOUT WRITTEN PERMISSION FROM THE CITY OF CHICAGO DEPARTMENT OF WATER AND/OR DEPARTMENT OF SEWERS.

CURB AND GUTTER CONSTRUCTION SHALL PROVIDE A MINIMUM CURB HEIGHT OF 75 mm (3").

BACK FILL MATERIAL UNDER SIDEWALKS SHALL BE FA-2.

PAVEMENT REPLACEMENT AROUND FRAMES AND GRATES OR LIDS WHERE DRAINAGE, WATER MAIN OR ELECTRICAL STRUCTURES ARE ADJUSTED OR RECONSTRUCTED, SHALL BE WITH CLASS SI CONCRETE.

ALL PAVEMENT PATCHING SHALL BE CLASS C.

EXISTING LATERALS TO BE REUSED MUST BE RODDED AND FLUSHED IN THE PRESENCE OF THE SEWER INSPECTOR. A NEW CONNECTION TO THE MAIN SEWER IS REQUIRED IF THE EXISTING LATERAL IS NOT APPROVED BY THE INSPECTOR.

IN THE LOCATIONS WHERE THE MAIN SEWER IS NOT BEING REPLACED AND THE EXISTING DRAINAGE FACILITIES ARE DISTURBED OR DAMAGED DURING CONSTRUCTION BY THE CONTRACTOR, IT WILL BE THE CONTRACTOR'S RESPONSIBILITY TO RESTORE AND REPLACE THE DAMAGED FACILITIES AT HIS/HER EXPENSE TO THE SATISFACTION OF THE DEPARTMENT OF SEWERS. THE SEWER FLOW MUST BE MAINTAINED AT ALL TIMES.

AS-BUILT PLANS MUST BE SUBMITTED SOON AFTER WORK COMPLETION, FINAL PAYMENT SHALL NOT BE MADE TO THE CONTRACTOR UNTIL THE DEPARTMENT OF SEWERS ACKNOWLEDGES RECEIPT OF AS-BUILT PLANS.

LOCAL ROADS, RESIDENTIAL DRIVEWAYS AND PROPERTY ACCESS DRIVES MUST REMAIN OPEN TO TRAFFIC AT ALL TIMES. SHOULD A TEMPORARY CLOSURE BE NECESSARY, THE CONTRACTOR SHALL NOTIFY THE CITY OF CHICAGO AND/OR THE AFFECTED PROPERTY OWNER TWENTY FOUR (24) HOURS IN ADVANCE OF SUCH CLOSURE. CONSTRUCTION ACTIVITIES SHALL BE EXPEDITED AND ACCESS RESTORED WITHIN AN ADEQUATE TIME FRAME OR AS DIRECTED BY THE ENGINEER, CITY OF CHICAGO.

PRIOR TO WORK AND UPON WORK COMPLETION, THE CONTRACTOR SHALL PROVIDE TO THE DEPARTMENT OF SEWERS, FOR REVIEW AND ACCEPTANCE, A VIDEOTAPE OF THE SEWER MAINS ALONG THE PROJECT EXTENTS. THIS WORK SHALL BE PAID UNDER THE PAY ITEM VIDEO, TAPING STORM SEWER.

DURING CONSTRUCTION, THE CONTRACTOR SHALL MAINTAIN ALL SURFACE DRAINAGE WITHIN THE PROJECT LIMITS. ALL STORM SEWER FLOW MUST BE MAINTAINED AT ALL TIMES, UNLESS OTHERWISE DIRECTED BY THE ENGINEER. PLATING OF THE DRAINAGE STRUCTURES FOR STRUCTURE ADJUSTMENT SHALL NOT BE PERMITTED.

THE CONTRACTOR SHALL FEATHER THE BITUMINOUS LAYERS AROUND THE DRAINAGE STRUCTURES TO PREVENT A BUMP. THIS WORK SHALL BE INCLUDED IN THE COST FOR HOT-MIX ASPHALT SURFACE REMOVAL, 60 mm.

REVISIONS		ILLINOIS DEPARTMENT OF TRANSPORTATION INDEX OF SHEETS AND CITY OF CHICAGO NOTES 115th STREET
NAME	DATE	
		DRAWN BY: PRH CHECKED BY: JMH DATE: JANUARY 16, 2009

**COLLINS ENGINEERS**  
123 North Wacker Drive  
Suite 300  
Chicago, IL 60606  
(312) 704-9300  
www.collinsengr.com  
ILLINOIS PROFESSIONAL DESIGN FIRM LICENSE NO. 184-000993

F.A.I.	SECTION	COUNTY	TOTAL SHEETS	SHEET NO.
57	1919.2B	COOK	119	3
FED. ROAD DIST. NO.		ILLINOIS FED. AID PROJECT	CONTRACT 60371	

STATE STANDARDS

SHEET NO.	DESCRIPTION
000001-05	STANDARD SYMBOLS, ABBREVIATIONS AND PATTERNS
001001-02	AREAS OF REINFORCEMENT REBARS
001006	DECIMAL OF AN INCH AND OF A FOOT
280001-04	TEMPORARY EROSION CONTROL SYSTEMS
420001-07	PAVEMENT JOINTS
420111-02	PCC PAVEMENT ROUNDOUTS
424001-05	SIDEWALK RAMPS ACCESSIBLE TO THE DISABLED
442201-03	CLASS C AND D PATCHES
515001-03	NAME PLATE FOR BRIDGES
606001-04	CONCRETE CURB TYPE B AND COMBINATION CONCRETE CURB AND GUTTER
664001-02	CHAIN LINK FENCE
701101-02	MULTILANE OFF-ROAD OPERATIONS
701106-02	OFF ROAD OPERATIONS, MULTILANE MORE THAN 4.5 m AWAY FOR SPEEDS >= 45MPH
701301-03	LANE CLOSURE, 2L 2W, SHORT TIME OPERATIONS
701306-02	LANE CLOSURE, 2L 2W, SLOW MOVING OPERATIONS - DAY ONLY FOR SPEEDS >= 45MPH
701321-10	LANE CLOSURE, 2L 2W, BRIDGE REPAIR WITH BARRIER
701400-03	APPROACH TO LANE CLOSURE, FREEWAY/EXPRESSWAY
701401-05	LANE CLOSURE, FREEWAY/EXPRESSWAY
701411-05	LANE CLOSURE, MULTILANE AT ENTRANCE OR EXIT RAMPS FOR SPEEDS > 45MPH
701446-01	TWO LANE CLOSURE, FREEWAY/EXPRESSWAY
701501-05	URBAN LANE CLOSURE, 2L 2W, UNDIVIDED
701601-04	URBAN LANE CLOSURE, MULTILANE 1W OR 2W WITH NON TRAVERSABLE MEDIAN
701606-06	URBAN LANE CLOSURE, MULTILANE 2W WITH MOUNTABLE MEDIAN
701701-06	URBAN LANE CLOSURE, MULTILANE INTERSECTION
701801-04	LANE CLOSURE, MULTILANE 1W OR 2W CROSSWALK OR SIDEWALK CLOSURE
701901-01	TRAFFIC CONTROL DEVICES
704001-05	TEMPORARY CONCRETE BARRIER
720001-01	SIGN PANEL MOUNTING DETAILS
720006-02	SIGN PANEL ERECTION DETAILS
720011-01	METAL POSTS (SIGNS, MARKERS, AND DELINEATORS)
720016-02	MAST ARM MOUNTED STREET NAME SIGNS

GENERAL NOTES (CONTINUED)

EXTREME CAUTION IS TO BE TAKEN TO ENSURE THAT NO FACILITY OWNED AND MAINTAINED BY THE DEPARTMENT IS DAMAGED DURING CONSTRUCTION. IF ANY DAMAGE OCCURS TO ANY FACILITIES, THE DEVELOPER AND CONTRACTOR WILL BE HELD RESPONSIBLE FOR THE COST OF REPAIRING OR REPLACING THEM.

THE CONTRACTOR'S ATTENTION IS CALLED TO THE FACT THAT THE PRESERVATION OF EXISTING TREES IS OF UTMOST IMPORTANCE TO THE CITY OF CHICAGO. ALL TREE PROTECTION, TREE REMOVAL, PRUNING AND ROOT PRUNING SHALL BE COMPLETED BEFORE CONSTRUCTION OPERATIONS COMMENCE IN ANY AREA. AT NO TIME SHALL THE CONTRACTOR PRUNE OR REMOVE ANY TREES UNLESS SPECIFICALLY DIRECTED BY THE ENGINEER.

TEMPORARY FENCE SHALL BE ERECTED ALONG THE DRIP LINE OF EXISTING TREES AND IS TO REMAIN WITHIN THE LIMITS OF CONSTRUCTION. AFTER TREES ARE SAFELY FENCED NOTHING IS TO BE STORED, DRIVEN, OR DISTURBED INSIDE THE FENCE. REMOVE PROTECTIVE TEMPORARY FENCE ONLY AFTER ALL CONSTRUCTION WORK HAS BEEN COMPLETED.

THE CONTRACTOR SHALL TAKE EXTRA CARE IN GRADING AND EXCAVATING NEAR TREES WHICH ARE NOT MARKED FOR REMOVAL SO AS NOT TO CAUSE INJURY TO THE ROOT SYSTEM OR TRUNKS. HAND EXCAVATION SHALL BE PERFORMED IF MAJOR ROOTS ARE PRESENT. MAJOR ROOTS OF A TREE THAT ARE TO REMAIN IN PLACE EXTENDING INTO THE EXCAVATION AREAS AT AN ELEVATION THAT WOULD INTERFERE WITH ANY PORTION OF THE PLANNED CONSTRUCTION SHALL BE SEVERED AT A POINT IMMEDIATELY OUTSIDE OF THE EXCAVATION AREA IN A MANNER THAT WILL CAUSE THE LEAST AMOUNT OF SYSTEMIC DAMAGE TO THE REMAINING TREE STRUCTURE. THE EXPENSE OF ANY REQUIRED HAND EXCAVATION AS DESCRIBED ABOVE, SHALL BE CONSIDERED INCLUDED IN THE COST OF THE CONTRACT LINE ITEM BEING REMOVED OR INSTALLED AT THAT LOCATION.

TREE ROOT PRUNING IS TO BE USED ON EXISTING TREES TO PREVENT THE RIPPING UP OF ROOTS WHEN TRENCHING OR EXCAVATION IS WITHIN THE ROOT ZONE OF ADJACENT TREES TO REMAIN TO REMAIN. SUPPLEMENTAL WATERING OF TREES SHOULD BEGIN IMMEDIATELY AFTER ROOT PRUNING OF THE TREES HAS OCCURRED.

THE CONTRACTOR SHALL USE CARE IN GRADING OR EXCAVATING NEAR ANY AND ALL EXISTING TREES WHICH WILL NOT BE REMOVED. ANY DAMAGE TO EXISTING ITEMS BY THE CONTRACTOR SHALL BE REPAIRED BY THE CONTRACTOR AT THE CONTRACTOR'S OWN EXPENSE.

USE NO. 25 (#8) EPOXY-COATED TIE BARS CONFORMING TO ARTICLE. 1006.10(B)(2) OF THE STANDARD SPECIFICATIONS FOR LONGITUDINAL CONSTRUCTION JOINT GROUTED-IN-PLACE TIE BAR AS SHOWN ON STATE STANDARD 420001 AND FOR TIEING PC CONCRETE WIDENING TO EXISTING CONCRETE PAVEMENT AS SHOWN ON THE PLANS. THE TIE BARS WILL NOT BE PAID FOR SEPARATELY BUT SHALL BE INCLUDED IN THE COST OF THE PAVEMENT ITEMS BEING CONSTRUCTED.

WHEN MILLED PAVEMENT IS OPEN TO TRAFFIC THE MAXIMUM GRADE DEFERENTIAL BETWEEN PASSES OF THE MILLING MACHINE SHALL NOT EXCEED 40 mm (1 1/2 INCHES) WHERE THE SPEED LIMIT IS 80 KM/H (45 MPH) OR LESS AND 25 mm (1 INCH) WHERE THE SPEED LIMIT IS GREATER THAN 80 KM/H (45 MPH). WITH WRITTEN APPROVAL FROM THE ENGINEER, A MAXIMUM GRADE DIFFERENTIAL OF 75 mm (3 INCHES) MAY BE ALLOWED IF THE EDGE OF THE MILLING IS SLOPED A MINIMUM 1:3 (V:H).

BUTT JOINTS WILL BE INSTALLED AT THE ENDS OF ALL RESURFACING (WHERE RESURFACING MEETS EXISTING PAVEMENT), IN ACCORDANCE WITH THE "BUTT JOINT AND HMA TAPER DETAILS" SHEET INCLUDED IN THE PLANS, UNLESS OTHERWISE SPECIFIED.

ALL DIMENSIONS ARE SHOWN IN MILLIMETERS UNLESS OTHERWISE NOTED.

THE LOCATIONS AND ELEVATIONS OF EXISTING SEWERS AND SEWER STRUCTURES SHOWN ON THE PLANS AND PROFILES HAVE BEEN OBTAINED FROM DRAWINGS AND ATLASES AND THE INFORMATION IS NOT GUARANTEED. THE CONTRACTOR IS RESPONSIBLE FOR FIELD VERIFYING AND PROTECTING ALL SEWER AND STRUCTURES.

SAW CUTS REQUIRED FOR PAVEMENT REMOVAL OR HOT-MIX ASPHALT SURFACE REMOVAL WILL NOT BE PAID FOR SEPARATELY, BUT SHALL BE INCLUDED IN THE COST OF PAVEMENT REMOVAL AND HOT-MIX ASPHALT SURFACE REMOVAL- BUTT JOINT.

3 METER TRANSITIONS SHALL BE USED TO MATCH PROPOSED ITEMS OF WORK TO THE EXISTING ITEMS IN THE FIELD, UNLESS OTHERWISE SHOWN. THE TRANSITIONS SHALL BE PAID FOR AT THE CONTRACT UNIT PRICE FOR THE PROPOSED ITEM OF WORK SPECIFIED.

ALL DIMENSIONS SHOWN ON THE PLANS ARE TO THE EDGE OF PAVEMENT UNLESS OTHERWISE NOTED.

WHERE NEEDED, THE CONTRACTOR SHALL DETERMINE THE ELEVATIONS AT THE PERSPECTIVE PROPERTY LINES BEFORE SETTING THE TOP OF CURB ELEVATIONS AND, ADJUST THE CURB EXPOSURE AND/OR GUTTER ELEVATIONS IN ORDER TO PROVIDE ADEQUATE GRADES AS APPROVED BY THE ENGINEER.

GENERAL NOTES (CONTINUED)

THE DEPARTMENT DOES NOT GUARANTEE THE COMPLETENESS OR ACCURACY OF THE INFORMATION SHOWN ON THE PLANS REGARDING PUBLIC AND PRIVATE UTILITIES, SUCH AS SEWERS, MANHOLES, CATCH BASINS, INLETS, GAS LINES, WATER MAINS, TELEPHONE LINES, ELECTRICAL DUCTS LINES AND OTHER UTILITY SYSTEMS. THE CONTRACTOR SHALL VERIFY THE EXACT LOCATION OF ALL UTILITIES THAT MAY INTERFERE WITH CONSTRUCTION OPERATIONS AND REPORT TO THE DEPARTMENT ANY OMISSIONS AND DIFFERENCES FROM THE LOCATIONS SHOWN ON THE PLANS. THIS WORK WILL BE INCLUDED IN THE COST OF THE CONTRACT.

THE CONTRACTOR SHALL PROTECT EXISTING AND NEW UTILITIES USING METHODS APPROVED OF BY THE ENGINEER. THE CONTRACTOR SHALL BRACE AND SUPPORT THE UTILITIES PROPERLY TO PREVENT SETTLEMENT DISPLACEMENT OR CHANGE TO THE UTILITIES. THE PROTECTION OF THE UTILITIES WILL BE INCLUDED IN THE COST OF THE CONTRACT.

PRIOR TO CONSTRUCTION, AND AS DIRECTED BY THE ENGINEER THE CONTRACTOR SHALL MAINTAIN ALL SURFACE DRAINAGE WITHIN THE PROJECT LIMITS. ALL STORM SEWER FLOW MUST BE MAINTAINED AT ALL TIMES, UNLESS OTHERWISE DIRECTED BY THE ENGINEER.

PRIOR TO CONSTRUCTION OPERATIONS, TEMPORARY FILTER MUST BE PROVIDED AT MANHOLES, CATCH BASINS AND INLETS TO PREVENT ENTRY OF ASPHALT/DEBRIS INTO THE SEWER SYSTEM.

THE IMPROVEMENT IMPACTS CTA BUS ROUTE #111. DURING CONSTRUCTION, A MINIMUM OF ONE LANE OF TRAFFIC IN EACH DIRECTION SHALL BE MAINTAINED. CONTRACTOR IS TO INFORM THE CTA/RTA 28 DAYS IN ADVANCE OF THE START OF CONSTRUCTION.

ALL UTILITY RELOCATIONS OR ADJUSTMENTS SHALL BE PERFORMED BY THE RESPECTIVE UTILITY OWNERS AT THEIR EXPENSE AND SHALL NOT BE CONSIDERED AS PART OF THIS CONTRACT UNLESS OTHERWISE SHOWN, THE CONTRACTOR SHALL NOTIFY THE AFFECTED UTILITIES AND SCHEDULE WORK ACCORDINGLY. THIS COORDINATION WILL BE INCLUDED IN THE COST OF THE CONTRACT.

DURING HOT-MIX ASPHALT SURFACE REMOVAL AND SUBSEQUENT RESURFACING, THE MILLING MACHINE SHALL HAVE AN EFFECTIVE MEANS FOR REMOVING ALL LOOSE AND EXCESS MATERIAL FROM THE SURFACE, WHILE PREVENTING DUST FROM ESCAPING INTO THE AIR. THIS WORK SHALL BE INCLUDED IN THE COST FOR HMA SURFACE REMOVAL.

A QUANTITY FOR PAVEMENT PATCHING, CLASS C, HAS BEEN ESTIMATED AT THE RATE THAT IS SHOWN ON THE SCHEDULE OF QUANTITIES. ALL AREAS OF PAVEMENT PATCHING SHALL BE PERFORMED BY THE CONTRACTOR AND APPROVED BY THE ENGINEER BEFORE AND AFTER PLACEMENT. ALL PAVEMENT PATCHING SHALL BE COMPLETED PRIOR TO MILLING OPERATIONS.

COMMITMENTS

BEFORE UNDERGROUND SEWER WORK IS STARTED, A PERMIT FROM THE CHICAGO DEPARTMENT OF SEWERS WILL BE OBTAINED.

GENERAL NOTES

THE CONTRACTOR SHALL COORDINATE CONSTRUCTION ACTIVITIES WITH UTILITY COMPANIES, THE CITY OF CHICAGO AND THE CTA/RTA.

BEFORE STARTING ANY EXCAVATION, THE CONTRACTOR SHALL CALL C.U.A.N. AT (312) 744-7000 FOR FIELD LOCATIONS OF BURIED ELECTRIC, TELEPHONE AND GAS FACILITIES. IN ADDITION, THE CONTRACTOR SHALL CONTACT THE CITY OF CHICAGO FOR FIELD LOCATIONS OF WATER MAIN, SANITARY SEWER AND ALL CITY UTILITIES. (48 HOURS NOTIFICATION SHALL BE REQUIRED.)

THE CONTRACTOR SHALL COORDINATE ANY LANE CLOSURES ON I-57 WITH OTHER CONCURRENT (I-57) PROJECTS AND THE BUREAU OF TRAFFIC AT IDOT.

THE CONTRACTOR WILL NOT BE ALLOWED TO SET UP A YARD OR FIELD OFFICE ON STATE PROPERTY WITHOUT WRITTEN CONSENT FROM THE DEPARTMENT.

WHEN ARTIFICIAL LIGHTING IS UTILIZED IN NIGHT OPERATIONS, THE CONTRACTOR SHALL EXERCISE THE UTMOST PRECAUTIONS PREVENTING ADVERSE VISIBILITY TO THE MOTORING PUBLIC AND ADJOINING RESIDENTIAL AREAS.

ALL ELEVATIONS REFER TO U.S.G.S. MEAN SEA LEVEL DATUM.

THE CONTRACTOR SHALL SUBTRACT 176.574 m FROM THE ELEVATIONS SHOWN ON THE PLANS TO OBTAIN CITY OF CHICAGO DATUM (CCD).

THE RESIDENT ENGINEER AND THE CONTRACTOR SHALL FIELD-VERIFY THE CITY'S EXISTING SEWER FACILITIES INCLUDING PUBLIC AND PRIVATE DRAIN CONNECTIONS IN THE LIMITS OF THE REFERENCED PROJECT FOR ANY CONFLICTS DUE TO PROPOSED IMPROVEMENTS. ANY CONFLICT SHOULD BE RESOLVED WITH THE DEPARTMENT OF WATER MANAGEMENT PRIOR TO THE START OF CONSTRUCTION.

THERE ARE NUMEROUS MANHOLES, CATCH BASINS AND INLETS WHICH MUST BE PROTECTED FROM ENTRY OF ASPHALT/DEBRIS INTO THE SEWER SYSTEM DURING CONSTRUCTION. THE CONTRACTOR MUST MARK LOCATIONS OF ALL SEWER STRUCTURES ON THE SIDEWALK BEFORE STARTING PAVEMENT REMOVAL/REPLACEMENT. A PERMIT FROM THE DEPARTMENT OF WATER MANAGEMENT SHOULD BE OBTAINED IN ADVANCE FOR ANY UNDERGROUND SEWER WORK INCLUDING ADJUSTMENT OF STRUCTURES, REMOVAL OR REPLACEMENT OF FRAMES AND LIDS, TELEVISION SURVEYS, CLEANING, LINING AND INSPECTIONS BY A LICENSED SEWER CONTRACTOR AT 333 S. STATE STREET, SUITE 410, CHICAGO, ILLINOIS 60604.

REVISIONS

NAME	DATE

ILLINOIS DEPARTMENT OF TRANSPORTATION  
STATE STANDARDS,  
GENERAL NOTES AND COMMITMENTS  
115th STREET

DRAWN BY: PRH

DATE: JANUARY 16, 2009

CHECKED BY: JMH



FILE: g:\2904\civil\exhib\1\2904003.dgn DATE: 20-AUG-08 14:24

LOCATION OF WORK:  
 FAU ROUTE 1584 (115th STREET)  
 OVER FAI ROUTE 57  
 COOK COUNTY

F.A.I.	SECTION	COUNTY	TOTAL SHEETS	SHEET NO.
57	1919.2B	COOK	119	4
FED. ROAD DIST. NO.		ILLINOIS	FED. AID PROJECT	
		CONTRACT 60371		

SUMMARY OF QUANTITIES				CONSTRUCTION TYPE CODES			
CODE NO.	PAY ITEM	UNIT	100% FED. URBAN TOTAL QUANTITY	ROADWAY 1000	BRIDGE X731-2A	TRAFFIC SIGNAL- Y031-1F	HIGHWAY LIGHTING Y030-1E
• 20101200	TREE ROOT PRUNING	EACH	2	2			
• M2011350	TREE PRUNING (OVER 250MM DIAMETER)	EACH	3	3			
28000510	INLET FILTERS	EACH	8	8			
50104720	REMOVAL OF EXISTING CONCRETE DECK	EACH	1		1		
50500715	JACK AND REMOVE EXISTING BEARINGS	EACH	28		28		
50800515	BAR SPLICERS	EACH	714		714		
51500100	NAME PLATES	EACH	1		1		
52100010	ELASTOMERIC BEARING ASSEMBLY, TYPE I	EACH	28		28		
60300305	FRAMES AND LIDS TO BE ADJUSTED	EACH	26	26			
60300310	FRAMES AND LIDS TO BE ADJUSTED (SPECIAL)	EACH	15	15			
67000400	ENGINEER'S FIELD OFFICE, TYPE A	CAL MO	12	12			
67100100	MOBILIZATION	L SUM	1	0.5	0.5		
70101800	TRAFFIC CONTROL AND PROTECTION, (SPECIAL)	L SUM	1	0.5	0.5		
70103815	TRAFFIC CONTROL SURVEILLANCE	CAL DA	100	100			
70106800	CHANGEABLE MESSAGE SIGN	CAL MO	4	4			
• 82107200	UNDERPASS LUMINAIRE, 100 WATT, HIGH PRESSURE SODIUM VAPOR	EACH	8				8
• 82107300	UNDERPASS LUMINAIRE, 150 WATT, HIGH PRESSURE SODIUM VAPOR	EACH	8				8
• 84200600	REMOVAL OF EXISTING LIGHTING UNIT, NO SALVAGE	EACH	12				12
• 84400105	RELOCATE EXISTING LIGHTING UNIT	EACH	3				3
• 88010180	SIGNAL HEAD, ALUMINUM, 1-FACE, 3-SECTION, BRACKET MOUNTED	EACH	4			4	
• 88010190	SIGNAL HEAD, ALUMINUM, 1-FACE, 3-SECTION, MAST ARM MOUNTED	EACH	10			10	
• 88010220	SIGNAL HEAD, ALUMINUM, 1-FACE, 4-SECTION, BRACKET MOUNTED	EACH	2			2	
• 88010230	SIGNAL HEAD, ALUMINUM, 1-FACE, 4-SECTION, MAST ARM MOUNTED	EACH	2			2	
• 88100200	PEDESTRIAN SIGNAL HEAD, 1-FACE, BRACKET MOUNTED	EACH	12			12	
• 89000100	TEMPORARY TRAFFIC SIGNAL INSTALLATION	EACH	2			2	
• 89502375	REMOVE EXISTING TRAFFIC SIGNAL EQUIPMENT	EACH	2			2	
• 89502385	REMOVE EXISTING CONCRETE FOUNDATION	EACH	5			5	
• E20200G1	VINE - PARTHENOCISSUS QUINQUEFOLIA (VIRGINIA CREEPER), 1 - GALLON POT	EACH	100	100			
• M2011000	TEMPORARY FENCE	METER	436	436			
• M2011700	SUPPLEMENTAL WATERING	UNIT	8.0	8.0			
• M2020010	EARTH EXCAVATION	CU M	65	65			
• M2070400	POROUS GRANULAR EMBANKMENT, SPECIAL	CU M	86		86		
• M2080150	TRENCH BACKFILL	CU M	15	15			
• M2113100	TOPSOIL FURNISH AND PLACE, 100MM	SO M	132	132			
• M2500210	SEEDING, CLASS 2A	HA	0.1	0.1			
• M2500400	NITROGEN FERTILIZER NUTRIENT	KG	5	5			
• M2500500	PHOSPHORUS FERTILIZER NUTRIENT	KG	5	5			
• M2500600	POTASSIUM FERTILIZER NUTRIENT	KG	5	5			
• M2510630	EROSION CONTROL BLANKET	SO M	333	333			

•= SPECIALTY ITEM  
 += NON PARTICIPATING ITEM

REVISIONS		ILLINOIS DEPARTMENT OF TRANSPORTATION  SUMMARY OF QUANTITIES  DRAWN BY: PRH CHECKED BY: JMH DATE: JANUARY 16, 2009
NAME	DATE	

**COLLINS ENGINEERS**  
 123 North Wacker Drive  
 Suite 300  
 Chicago, IL 60606  
 (312) 704-9300  
 www.collinsengr.com  
 ILLINOIS PROFESSIONAL DESIGN FIRM LICENSE NO. 184-000993

FILE: g:\2904\civil\exhibit\2904004.dgn  
 DATE: 19-Nov-07 15:55

SUMMARY OF QUANTITIES		100% FED. URBAN		CONSTRUCTION TYPE CODES			
CODE NO.	PAY ITEM	UNIT	TOTAL QUANTITY	ROADWAY 1000	BRIDGE X731-2A	TRAFFIC SIGNAL-Y031-1F	HIGHWAY LIGHTING Y030-1E
M2520110	SODDING, SALT TOLERANT	SO M	132	132			
M2800250	TEMPORARY EROSION CONTROL SEEDING	KG	4	4			
M2800400	PERIMETER EROSION BARRIER	METER	338	338			
M3111100	SUB-BASE GRANULAR MATERIAL, TYPE B 100MM	SO M	12	12			
M3530230	PORTLAND CEMENT CONCRETE BASE COURSE 230MM	SO M	12	12			
M4030200	BITUMINOUS MATERIALS (PRIME COAT)	M TON	1.7	1.7			
M4060300	AGGREGATE (PRIME COAT)	M TON	11	11			
M4060400	MIXTURE FOR CRACKS, JOINTS, AND FLANGEWAYS	M TON	1.2	1.2			
M4060982	HOT-MIX ASPHALT SURFACE REMOVAL - BUTT JOINT	SO M	98	98			
M4060990	TEMPORARY RAMP	SO M	164	164			
M4061005	HOT-MIX ASPHALT REPLACEMENT OVER PATCHES	M TON	21	21			
M4062135	LEVELING BINDER (MACHINE METHOD), N70	M TON	215	215			
M4063085	HOT-MIX ASPHALT BINDER COURSE, IL-19.0, N70	M TON	223	223			
M4063340	HOT-MIX ASPHALT SURFACE COURSE, MIX "D", N70	M TON	328	328			
M4200260	PORTLAND CEMENT CONCRETE PAVEMENT 260MM	SO M	103	103			
M4205050	BRIDGE APPROACH PAVEMENT (SPECIAL)	SO M	366	366			
M4230200	PORTLAND CEMENT CONCRETE DRIVEWAY PAVEMENT, 200MM	SO M	108	108			
M4240125	PORTLAND CEMENT CONCRETE SIDEWALK 125MM	SO M	659	659			
M4245000	TEMPORARY SIDEWALK	SO M	109	109			
M4248000	DETECTABLE WARNINGS	SO M	43	43			
M4400760	HOT-MIX ASPHALT SURFACE REMOVAL, 60MM	SO M	3272	3272			
M4401160	HOT-MIX ASPHALT REMOVAL OVER PATCHES, 60MM	SO M	232	232			
M4402000	PAVEMENT REMOVAL	SO M	285	285			
M4402010	DRIVEWAY PAVEMENT REMOVAL	SO M	108	108			
M4402040	COMBINATION CURB AND GUTTER REMOVAL	METER	416	416			
M4402050	SIDEWALK REMOVAL	SO M	500	500			
M4402060	APPROACH SLAB REMOVAL	SO M	234	234			
M4427020	CLASS C PATCHES, TYPE I, 225MM	SO M	85	85			
M4427220	CLASS C PATCHES, TYPE II, 225MM	SO M	69	69			
M4427320	CLASS C PATCHES, TYPE III, 225MM	SO M	78	78			
M4430020	STRIP REFLECTIVE CRACK CONTROL TREATMENT	METER	795	795			
M5010240	CONCRETE REMOVAL	CU M	30.3		30.3		
M5010570	PROTECTIVE SHIELD	SO M	1475		1475		
M5020100	STRUCTURE EXCAVATION	CU M	136		136		
M5030350	CONCRETE STRUCTURES	CU M	24.8		24.8		
M5030360	CONCRETE SUPERSTRUCTURE	CU M	477.7		477.7		
M5030390	BRIDGE DECK GROOVING	SO M	1087		1087		
M5030450	PROTECTIVE COAT	SO M	2218	641	1577		
M5050405	FURNISHING AND ERECTING STRUCTURAL STEEL	KG	6520		6520		

== SPECIALTY ITEM  
 += NON PARTICIPATING ITEM

REVISIONS	
NAME	DATE

ILLINOIS DEPARTMENT OF TRANSPORTATION

SUMMARY OF QUANTITIES

**COLLINS ENGINEERS**  
 123 North Wacker Drive  
 Suite 300  
 Chicago, IL 60606  
 (312) 704-9300  
 www.collinsengr.com  
 ILLINOIS PROFESSIONAL DESIGN FIRM LICENSE NO. 184-000993

DRAWN BY: PRH  
 CHECKED BY: JMH  
 DATE: JANUARY 16, 2009

SUMMARY OF QUANTITIES				CONSTRUCTION TYPE CODES			
CODE NO.	PAY ITEM	UNIT	TOTAL QUANTITY	100% FED. URBAN			
				ROADWAY 1000	BRIDGE X731-2A	TRAFFIC SIGNAL-Y031-1F	HIGHWAY LIGHTING Y030-1E
M5050410	STRUCTURAL STEEL REMOVAL	KG	3140		3140		
M5080205	REINFORCEMENT BARS, EPOXY COATED	KG	56600		56600		
M5090520	BRIDGE FENCE RAILING	METER	145.5		145.5		
M5120900	TEMPORARY SHEET PILING	SO M	28.4		28.4		
M5200225	PREFORMED JOINT STRIP SEAL	METER	50.9		50.9		
+ M5504800	STORM SEWERS TO BE CLEANED	METER	698	698			
M5870300	CONCRETE SEALER	SO M	37		37		
M5900200	EPOXY CRACK INJECTION	METER	70		70		
M6060070	CONCRETE CURB, TYPE B	METER	24.0	24.0			
M6060500	COMBINATION CONCRETE CURB AND GUTTER, TYPE B-15.30	METER	398	398			
M7030100	SHORT-TERM PAVEMENT MARKING	METER	176	176			
M7030210	TEMPORARY PAVEMENT MARKING - LETTERS AND SYMBOLS	SO M	8	8			
M7030220	TEMPORARY PAVEMENT MARKING - LINE 100MM	METER	964	964			
M7030240	TEMPORARY PAVEMENT MARKING - LINE 150MM	METER	61	61			
M7030270	TEMPORARY PAVEMENT MARKING - LINE 400MM	METER	12	12			
M7030280	TEMPORARY PAVEMENT MARKING - LINE 600MM	METER	50	50			
M7031000	WORK ZONE PAVEMENT MARKING REMOVAL	SO M	397	397			
M7040100	TEMPORARY CONCRETE BARRIER	METER	253.15	253.15			
M7040200	RELOCATE TEMPORARY CONCRETE BARRIER	METER	81	81			
M7800100	THERMOPLASTIC PAVEMENT MARKING - LETTERS AND SYMBOLS	SO M	1	1			
M7800105	THERMOPLASTIC PAVEMENT MARKING - LINE 100MM	METER	1194	1194			
M7800115	THERMOPLASTIC PAVEMENT MARKING - LINE 150MM	METER	191	191			
M7800125	THERMOPLASTIC PAVEMENT MARKING - LINE 300MM	METER	61	61			
M7800130	THERMOPLASTIC PAVEMENT MARKING - LINE 400MM	METER	25	25			
M7800140	THERMOPLASTIC PAVEMENT MARKING - LINE 600MM	METER	55	55			
M7802000	POLYUREA PAVEMENT MARKING TYPE I - LETTERS AND SYMBOLS	SO M	7	7			
M7802010	POLYUREA PAVEMENT MARKING TYPE I - LINE 100MM	METER	313	313			
M7802015	POLYUREA PAVEMENT MARKING TYPE I - LINE 150MM	METER	57	57			
M7802030	POLYUREA PAVEMENT MARKING TYPE I - LINE 300MM	METER	65	65			
M7802060	POLYUREA PAVEMENT MARKING TYPE I - LINE 600MM	METER	20	20			
M7830100	PAVEMENT MARKING REMOVAL	SO M	160	160			
• M8080110	TEMPORARY WOOD POLE, 12.19 METER, CLASS 4	EACH	2				2
• M8100070	CONDUIT IN TRENCH, 65MM DIA., GALVANIZED STEEL	METER	73				73
• M8130120	JUNCTION BOX, STAINLESS STEEL, ATTACHED TO STRUCTURE, 150 MM X 150 MM X 100 MM	EACH	8				8
• M8130185	JUNCTION BOX, STAINLESS STEEL, ATTACHED TO STRUCTURE, 300 MM X 250 MM X 150 MM	EACH	4				4
• M8130220	JUNCTION BOX, STAINLESS STEEL, ATTACHED TO STRUCTURE, 400 MM X 300 MM X 150 MM	EACH	4				4
• M8130645	JUNCTION BOX, CAST IRON, ATTACHED TO STRUCTURE, 250 MM X 250 MM X 150 MM	EACH	4				4
• M8160400	UNIT DUCT, WITH 3-1/2 NO. 4 AND 1/2 NO. 6 GROUND, 600V (EPR-TYPE RHW), 30MM DIA., POLYETHYLENE	METER	150				150
• M8170415	ELECTRIC CABLE IN CONDUIT, 600V (EPR-TYPE RHW) 1/2 NO.6	METER	56				56
• M8170425	ELECTRIC CABLE IN CONDUIT, 600V (EPR-TYPE RHW) 1/2 NO. 10	METER	483				483

• = SPECIALTY ITEM  
 += NON PARTICIPATING ITEM

REVISIONS		ILLINOIS DEPARTMENT OF TRANSPORTATION
NAME	DATE	
		SUMMARY OF QUANTITIES

**COLLINS ENGINEERS**  
 123 North Wacker Drive  
 Suite 300  
 Chicago, IL 60606  
 (312) 794-9300  
 www.collinsengr.com  
 ILLINOIS PROFESSIONAL DESIGN FIRM LICENSE NO. 184-000993

DATE: JANUARY 16, 2009  
 DRAWN BY: PRH  
 CHECKED BY: JMH

FILE: g:\2904\civil\exhibit\2904006.dgn  
 DATE: 19-Nov-07 15:52

SUMMARY OF QUANTITIES				CONSTRUCTION TYPE CODES			
CODE NO.	PAY ITEM	UNIT	TOTAL QUANTITY	100% FED. URBAN			
				ROADWAY 1000	BRIDGE X731-2A	TRAFFIC SIGNAL-Y031-1F	HIGHWAY LIGHTING Y030-1E
M8170435	ELECTRIC CABLE IN CONDUIT, 600V (EPR-TYPE RHW) 2-1/C NO. 2	METER	80			80	
M8170470	ELECTRIC CABLE IN CONDUIT, 600V (EPR-TYPE RHW) 3-1/C NO. 4	METER	56				56
M8170820	ELECTRIC CABLE IN CONDUIT, 600V (EPR-TYPE USE) 3-1/C NO. 2/0	METER	157				157
M8180120	AERIAL CABLE, 3-1/C NO. 2 WITH MESSENGER WIRE	METER	215				215
M8180240	AERIAL CABLE, 4-1/C NO. 8 WITH MESSENGER WIRE	METER	135				135
M8190200	TRENCH AND BACKFILL FOR ELECTRICAL WORK	METER	140				140
M8190302	TRENCH AND BACKFILL WITH SCREENINGS OR SAND	METER	123				123
M8360100	LIGHT POLE FOUNDATION, 600MM DIAMETER	METER	8.4			4.2	4.2
M8360200	LIGHT POLE FOUNDATION, 750MM DIAMETER	METER	19.5			19.5	
M8731185	ELECTRIC CABLE IN CONDUIT, SIGNAL NO. 12 19C	METER	307			307	
M8780500	CONCRETE FOUNDATION (SPECIAL)	METER	3			3	
M8950230	REMOVE ELECTRIC CABLE FROM CONDUIT	METER	800			800	
MX030208	CONDUIT ATTACHED TO STRUCTURE, 65MM DIA. GALVANIZED STEEL, PVC COATED	METER	54				54
MX030300	CONDUIT ATTACHED TO STRUCTURE, 25MM DIA. GALVANIZED STEEL, PVC COATED	METER	132				132
MX032016	BRIDGE APPROACH PAVEMENT CONNECTOR (PCC) SPECIAL	SO M	73	73			
MX032178	TEMPORARY INFORMATION SIGNING	SO M	14	14			
MX032198	MAST ARM, STEEL, MONOTUBE 12.19 METER	EACH	3			3	
MX032309	ELECTRIC MANHOLE, 900MM X 1.2M X 1.2M, WITH 600MM FRAME AND LID	EACH	1				1
MX032313	MAST ARM, STEEL, MONOTUBE 10.70 METER	EACH	2			2	
MX032322	ADJUST <sup>ING</sup> EXISTING ELECTRICAL MANHOLE WITH 600MM FRAME AND LID	EACH	6			6	
MX032324	MAST ARM, STEEL, MONOTUBE 9.10 METER	EACH	1			1	
MX032634	PVC CONDUIT IN TRENCH 3-75MM (SCHEDULE #80)	METER	25.0			10.0	15.0
MX032680	WEED CONTROL, PRE-EMERGENT GRANULAR HERBICIDE	KG	14	14			
MX032750	MAST ARM, STEEL, STREET LIGHTING, 3.66 METER	EACH	2				2
MX032760	ELECTRICAL HANDHOLE, 760MM DIAMETER WITH 600MM FRAME AND LID	EACH	2				2
MX032767	CONCRETE FOUNDATION, 500MM DIAMETER	METER	1.5				1.5
MX032985	VIDEO TAPING STORM SEWERS	METER	698	698			
MX033100	REMOVAL OF ASBESTOS CEMENT CONDUIT	METER	228		228		
MX033364	TRENCH AND BACKFILL FOR 2 TO 4 DUCTS	METER	82			33	49
M8100280	CONDUIT IN TRENCH, 75MM DIA., PVC	METER	17.5				17.5
MX033367	PVC CONDUIT IN TRENCH 2-75MM (SCHEDULE #80)	METER	10			10	
M8120230	CONDUIT EMBEDDED IN STRUCTURE, 50MM DIA., PVC	METER	160				160
M8100260	CONDUIT IN TRENCH, 50MM DIA., PVC	METER	160				160
MX033694	STRUCTURAL REPAIR OF CONCRETE (DEPTH EQUAL TO OR LESS THAN 125MM)	SO M	43		43		
MX703200	WET TEMPORARY PAVEMENT MARKING TAPE, TYPE III	METER	3457	3457			
<del>MX810060</del>	<del>CONDUIT IN TRENCH, 50MM DIA., PVC, SCHEDULE 80</del>	<del>METER</del>	<del>5</del>				<del>5</del>
MX830101	LIGHT POLE, STEEL, 10.5M M.H., 3.65M MAST ARM, 7 GAUGE 254MM DIA., 381MM BOLT CIRCLE, 31.75MM ANCHOR RODS	EACH	2			2	
MX830104	LIGHT POLE, STEEL, 10.5M M.H., 3.65M MAST ARM, 3 GAUGE 318MM DIA., 419MM BOLT CIRCLE, 38.1MM ANCHOR RODS	EACH	5			5	
MX870010	ELECTRIC CABLE ASSEMBLY IN CONDUIT, 600V (EPR-TYPE TC) 2/C NO. 6 AND NO. 8 GROUND	METER	627				627

== SPECIALTY ITEM  
 += NON PARTICIPATING ITEM

REVISIONS		ILLINOIS DEPARTMENT OF TRANSPORTATION
NAME	DATE	
		SUMMARY OF QUANTITIES
		DRAWN BY: PRH CHECKED BY: JMH DATE: JANUARY 16, 2009

FILE: g:\2904\civil\exhibit\2904007.dgn  
 DATE: 19-Nov-07 15:59

SUMMARY OF QUANTITIES				CONSTRUCTION TYPE CODES			
CODE NO.	PAY ITEM	UNIT	TOTAL QUANTITY	100% FED. URBAN			
				ROADWAY 1000	BRIDGE X731-2A	TRAFFIC SIGNAL-Y031-IF	HIGHWAY LIGHTING Y030-1E
MZ037300	PAVEMENT GROOVING	SQ M	103	103			
X0320564	SOLID STATE PRETIMED CONTROLLER, 40 CIRCUIT, 24 INTERVAL, WITH ACTUATION INPUTS WITH FOUR CYCLE SOLID STATE TIME BASE COORDINATOR IN BASE INTO CABINET	EACH	2			2	
X0322424	TEMPORARY UNDERPASS LIGHTING INSTALLATION AND REMOVAL	L SUM	1				1
X0322425	CIRCUIT BREAKER, 1-POLE, 70 AMPERE, 480 VOLT IN EXISTING STREET LIGHT CONTROLLER	EACH	2			2	
X0323574	MAINTENANCE OF LIGHTING SYSTEM	CAL MO	9				9
X0324571	MAINTENANCE OF STREET LIGHTING SYSTEM (CITY OF CHICAGO)	L SUM	1				1
X0324893	BREAKDOWN HANDHOLE OR MANHOLE	EACH	3			1	2
X0329863	INTERCEPT EXISTING CONDUIT	EACH	3			2	1
X0329867	INSTALL LIGHT POLE MAST ARM & LUMINAIRE (MATERIAL PROVIDED BY THE CITY OF CHICAGO)	EACH	6				6
X0329888	REMOVE EXISTING STREET LIGHTING EQUIPMENT	L SUM	1				1
X0966500	SIGN, MESSAGE, ELECTRICALLY ILLUMINATED, MAST ARM MOUNTED	EACH	4			4	
X0966600	SIGN, MESSAGE, ELECTRICALLY ILLUMINATED, BRACKET MOUNTED	EACH	4			4	
X0966705	JUNCTION BOX, POLE OR POST MOUNTED, SPECIAL	EACH	8			8	
X4022000	TEMPORARY ACCESS (COMMERCIAL ENTRANCE)	EACH	4	4			
X4023000	TEMPORARY ACCESS (ROAD)	EACH	1	1			
X6040220	FRAMES AND LIDS, TYPE 1, OPEN LID (CITY OF CHICAGO)	EACH	1	1			
X7011015	TRAFFIC CONTROL AND PROTECTION (EXPRESSWAYS)	L SUM	1	1			
X8040100	ELECTRIC CONNECTION TO SIGN STRUCTURE	EACH	2				2
X8210451	LUMINAIRE, STREET LIGHTING, HIGH PRESSURE SODIUM VAPOR, 400 WATT, 240 VOLT	EACH	11				11
X8950090	RELOCATE EXISTING LIGHTING CONTROLLER	EACH	1				1
XX002293	REMOVE, STORE, AND RE-ERECT OVERHEAD SIGN STRUCTURE - BRIDGE MOUNTED	EACH	2		2		
XX005656	INLET FILTER CLEANING	EACH	16	16			
Z0013798	CONSTRUCTION LAYOUT	L SUM	1	0.5	0.5		
Z0018500	DRAINAGE STRUCTURES TO BE CLEANED	EACH	19	19			
Z0018940	DRILL EXISTING MANHOLE OR HANDHOLE	EACH	1			1	
Z0030250	IMPACT ATTENUATOR, TEMPORARY (NON-REDIRECTIVE) TEST LEVEL 3	EACH	4	4			
Z0030350	IMPACT ATTENUATOR, RELOCATE (NON-REDIRECTIVE) TEST LEVEL 3	EACH	2	2			
Z0048665	RAILROAD PROTECTIVE LIABILITY INSURANCE	L SUM	1	1			
Z0076600	TRAINEES	HOUR	1000	1000			
MX033763	ELECTRIC CABLE IN CONDUIT, SIGNAL NO. 12 10C	METER	140			140	
MX033765	LIGHT POLE, STEEL, 10.5M M.H., 3.65M MAST ARM, 3 GAUGE 279MM DIA., 438MM BOLT CIRCLE, 31.75MM ANCHOR RODS	EACH	1			1	
X8210454	LUMINAIRE, STREET LIGHTING, HIGH PRESSURE SODIUM VAPOR, 195 WATT, 240 VOLT	EACH	2				2
MX033766	MAST ARM, STEEL, STREET LIGHTING, 2.40 METER	EACH	3				3
MX033767	WET TEMPORARY PAVEMENT MARKING TAPE, TYPE III - LETTERS AND SYMBOLS	SO M	11	11			
MX033764	ROD AND CLEAN DUCT IN EXISTING CONDUIT SYSTEM	METER	440			440	
MX033468	STORM SEWER, DUCTILE IRON PIPE, TYPE 2, 200MM	METER	36	36			
A2005036	TREE, GYMNOCLADUS DIOICUS EXPRESSO (EXPRESSO KENTUCKY COFFEETREE), 1-3/4" CALIPER, BALLED AND BURLAPPED	EACH	11	11			

\*\* SPECIALTY ITEM  
 += NON PARTICIPATING ITEM  
 © Y080

REVISIONS	
NAME	DATE

ILLINOIS DEPARTMENT OF TRANSPORTATION

SUMMARY OF QUANTITIES

DRAWN BY: PRH  
 CHECKED BY: JMH

DATE: JANUARY 16, 2009



FILE: G:\2904\civil\exhibit\2904008.dgn  
 DATE: 19-NOV-07 15:59



F.A.I.	SECTION	COUNTY	TOTAL SHEETS	SHEET NO.
57	1919.2B	COOK	119	9
FED. ROAD DIST. NO.		ILLINOIS FED. AID PROJECT		

CONTRACT 60371

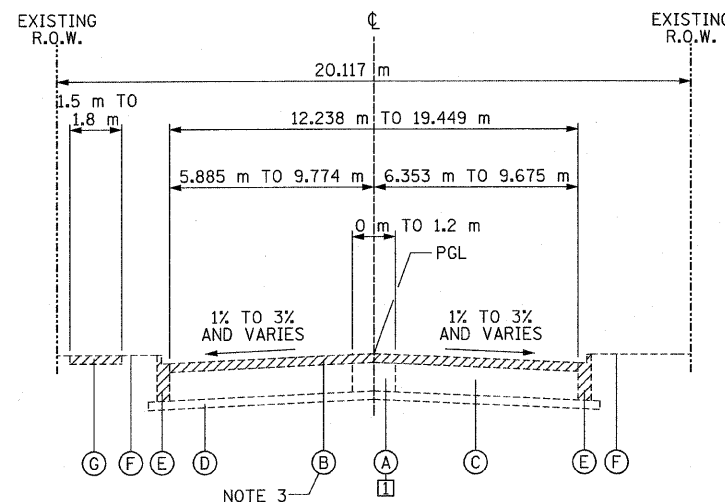

EXISTING TYPICAL SECTION

115TH STREET  
LOOKING EAST  
(STA. 2+261.000 TO STA. 2+317.460  
AND STA. 2+331.831 TO STA. 2+354.498)  
BACK OF WEST ABUTMENT STA. 2+354.404

1] STA. 2+295.049 TO STA. 2+324.914 AND  
STA. 2+345.927 TO 2+348.402

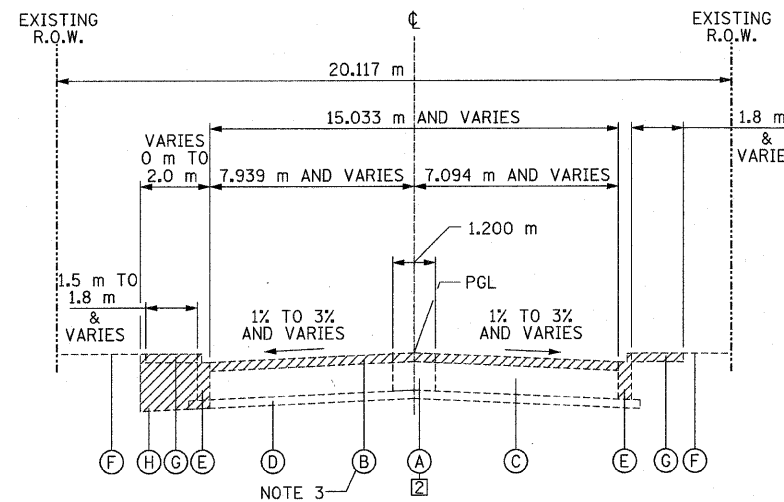

EXISTING TYPICAL SECTION

115TH STREET  
LOOKING EAST  
(STA. 2+317.460 TO STA. 2+324.914)

2] STA. 2+317.460 TO STA. 2+324.914

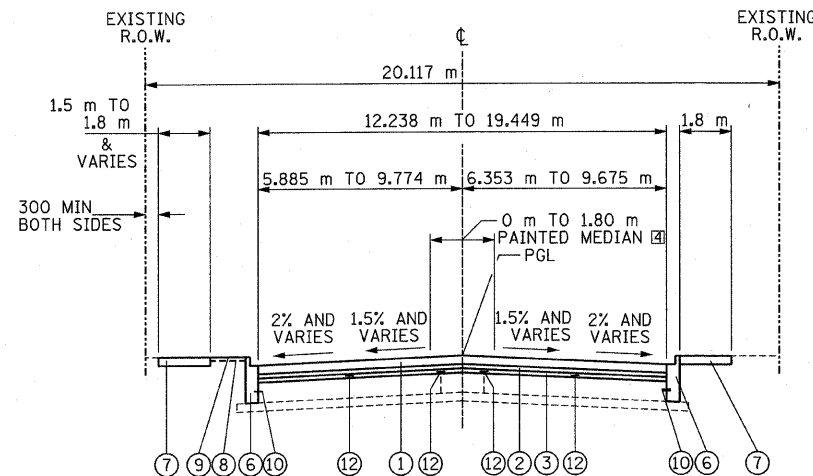

PROPOSED TYPICAL SECTION

115TH STREET  
LOOKING EAST  
(STA. 2+261.000 TO STA. 2+317.460  
AND STA. 2+331.831 TO STA. 2+354.498)  
BACK OF WEST ABUTMENT STA. 2+354.404

4] SEE PAVEMENT MARKING PLAN SHEET FOR LOCATION

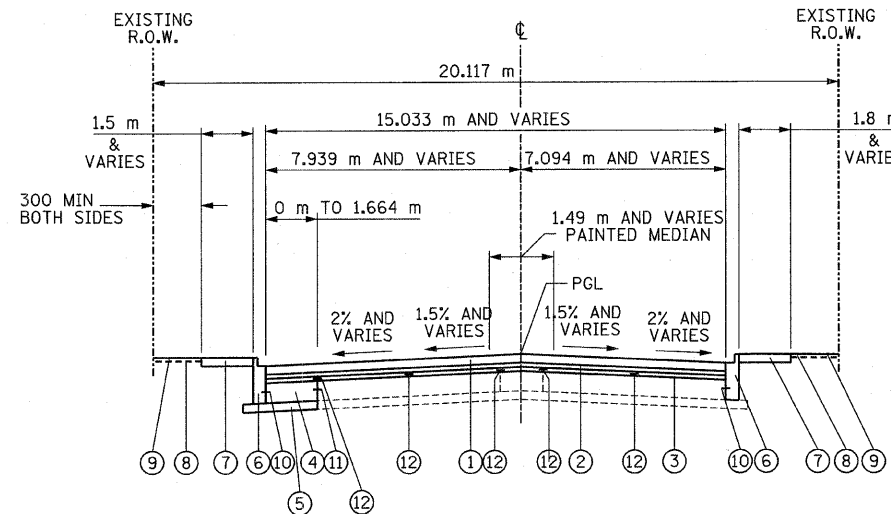

PROPOSED TYPICAL SECTION

115TH STREET  
LOOKING EAST  
(STA. 2+317.460 TO STA. 2+331.831)

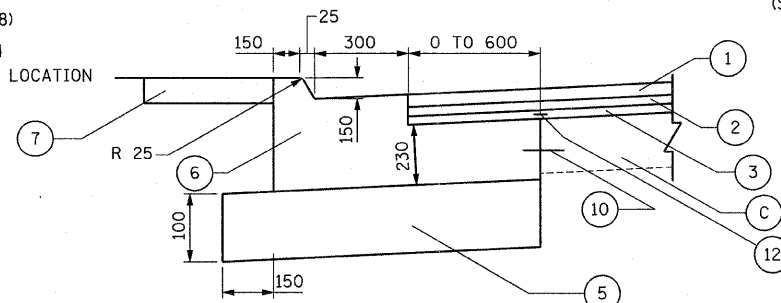

COMBINATION CONCRETE CURB AND  
GUTTER, TYPE B-15.30 (SPECIAL) DETAIL  
(SEE NOTE 2)

EXISTING TYPICAL SECTION LEGEND

- (A) CONCRETE MEDIAN (HAS BEEN SCARIFIED AND OVERLAID WITH HOT-MIX ASPHALT)
- (B) HOT-MIX ASPHALT BINDER AND SURFACE COURSE, 60 mm AND VARIES +/- 20 mm PAID AS HMA SURFACE REMOVAL, 60 mm
- (C) PORTLAND CEMENT CONCRETE BASE 230 AND VARIES
- (D) STABILIZED SUBBASE, 100
- (E) COMBINATION CURB AND GUTTER, TYPE B-15.30
- (F) TOPSOIL AND SODDING - TO BE REPLACED, AS REQUIRED
- (G) PORTLAND CEMENT CONCRETE SIDEWALK
- (H) EARTH EXCAVATION
- [Hatched Box] REMOVAL ITEM
- [Dashed Box] EXISTING ITEM

PROPOSED TYPICAL SECTION LEGEND

- 1] HOT-MIX ASPHALT SURFACE COURSE, MIX "D", N70, 38
- 2] POLYMERIZED HOT-MIX ASPHALT BINDER COURSE, IL-19.0, N70 (57 TO 206) (WHERE REQUIRED DUE TO RAISE IN PROFILE)
- 3] LEVELING BINDER (MACHINE METHOD), N70 (19 TO 57)
- 4] PORTLAND CEMENT CONCRETE BASE COURSE, 230
- 5] SUBBASE GRANULAR MATERIAL, TYPE B, 100
- 6] COMBINATION CONCRETE C & G, TYPE B-15.30
- 7] PORTLAND CEMENT CONCRETE SIDEWALK, 125
- 8] TOPSOIL FURNISH AND PLACE, 100 - AS REQUIRED
- 9] SODDING, SALT TOLERANT - AS REQUIRED
- 10] NO. 25 EPOXY COATED DEFORMED TIE BARS @ 600 mm C-C, 600 mm LONG, DRILLED AND GROUTED (WHERE REQUIRED). COST INCLUDED IN COMB. CONC. C & G, TYPE B-15.30
- 11] NO. 25 EPOXY COATED DEFORMED TIE BARS @ 600 mm C-C, 600 mm LONG, DRILLED AND GROUTED (WHERE REQUIRED). COST INCLUDED IN PORTLAND CEMENT CONC. BASE COURSE, 230
- 12] STRIP REFLECTIVE CRACK CONTROL TREATMENT (SEE NOTE 1)

- [Solid Box] PROPOSED ITEM
- [Dashed Box] EXISTING ITEM

NOTES:

1. ADDITIONAL CRACK CONTROL TREATMENT LOCATIONS MAY BE ADDED AS DIRECTED BY THE ENGINEER.
2. AREAS REQUIRING WIDENING 600 mm OR LESS SHOULD BE POURED MONOLITHICALLY WITH THE PROPOSED CURB AND GUTTER (SEE SPECIAL DETAIL). COMBINATION CONCRETE CURB AND GUTTER TYPE B-15.30 (SPECIAL) WILL NOT BE PAID FOR SEPARATELY, BUT WILL BE MEASURED AND PAID FOR AT THE CONTRACT UNIT PRICE FOR COMBINATION CONCRETE CURB AND GUTTER, TYPE B-15.30, IN ACCORDANCE WITH SECTION 606 OF THE STANDARD SPECIFICATIONS.
3. VARIABLE DEPTH MILLING WILL BE PAID FOR AS HOT-MIX ASPHALT SURFACE REMOVAL 60 mm IN SQUARE METERS. WHEN MILLING THE EXISTING HOT-MIX ASPHALT SURFACE, A MINIMUM OF 38 mm HOT-MIX ASPHALT LAYER SHOULD BE LEFT OVER THE EXISTING PCC PAVEMENT, UNLESS OTHERWISE DIRECTED BY THE ENGINEER. IF EXISTING HOT-MIX ASPHALT SURFACE, WHICH REMAINS AFTER MILLING IS LESS THAN 38 mm, ALL OF THE EXISTING HOT-MIX ASPHALT SURFACING SHALL BE REMOVED TO THE TOP OF THE CONCRETE PAVEMENT.
4. FOR DETAILS ON BRIDGE APPROACH PAVEMENT (SPECIAL) AND BRIDGE APPROACH PAVEMENT CONNECTOR (PCC) SPECIAL, SEE BRIDGE APPROACH PAVEMENT DETAILS SHEETS.
5. CROSS SLOPES WILL TRANSITION FROM ROADWAY CROSS SLOPES TO BRIDGE CROSS SLOPES AT THE BEGINNING AND END OF THE ROADWAY IMPROVEMENTS.

REVISIONS	
NAME	DATE

ILLINOIS DEPARTMENT OF TRANSPORTATION

TYPICAL SECTIONS

115TH STREET OVER I-57

DRAWN BY: PRH

DATE: JANUARY 16, 2009

CHECKED BY: JMH

**COLLINS ENGINEERS**  
123 North Wacker Drive  
Suite 300  
Chicago, IL 60606  
(312) 704-9300  
www.collinsengr.com  
ILLINOIS PROFESSIONAL DESIGN FIRM LICENSE NO. 184-000993

F.A.I.	SECTION	COUNTY	TOTAL SHEETS	SHEET NO.
57	1919.2B	COOK	119	10
FED. ROAD DIST. NO.		ILLINOIS FED. AID PROJECT	CONTRACT 60371	

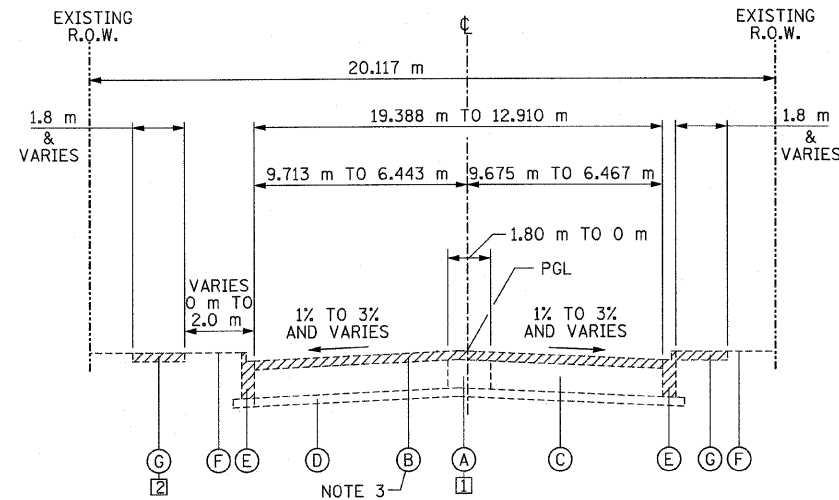

**EXISTING TYPICAL SECTION**  
 115TH STREET  
 LOOKING EAST  
 (STA. 2+411.332 TO STA. 2+445.700 AND STA. 2+475.600 TO STA. 2+519.400)  
 BACK OF EAST ABUTMENT 2+411.426  
 1 STA. 2+417.428 TO 2+420.687, STA. 2+442.254 TO STA. 2+445.700, AND STA. 2+475.600 TO STA. 2+501.090  
 2 PORTLAND CEMENT CONCRETE SIDEWALK EXTENDS TO STA. 2+538.812

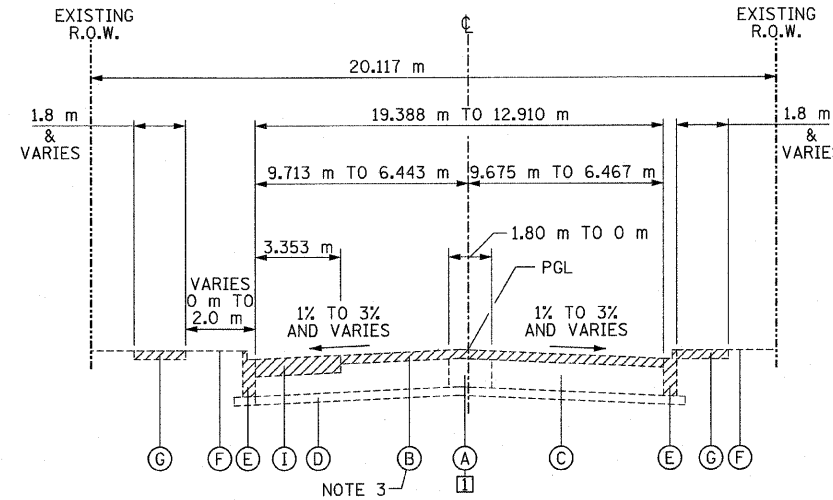

**EXISTING TYPICAL SECTION**  
 115TH STREET  
 LOOKING EAST  
 (STA. 2+445.700 TO STA. 2+475.600)  
 1 STA. 2+445.700 TO 2+475.600

**EXISTING TYPICAL SECTION LEGEND**

- (A) CONCRETE MEDIAN (HAS BEEN SCARIFIED AND OVERLAID WITH HOT-MIX ASPHALT)
  - (B) HOT-MIX ASPHALT BINDER AND SURFACE COURSE, 60 AND VARIES
  - (C) PORTLAND CEMENT CONCRETE BASE 230
  - (D) STABILIZED SUBBASE, 100
  - (E) COMBINATION CURB AND GUTTER, TYPE B-15.30
  - (F) TOPSOIL AND SODDING - TO BE REPLACED, AS REQUIRED
  - (G) PORTLAND CEMENT CONCRETE SIDEWALK
  - (H) EARTH EXCAVATION
  - (I) PORTLAND CEMENT CONCRETE PAVEMENT, 260 mm
- REMOVAL ITEM  
 EXISTING ITEM

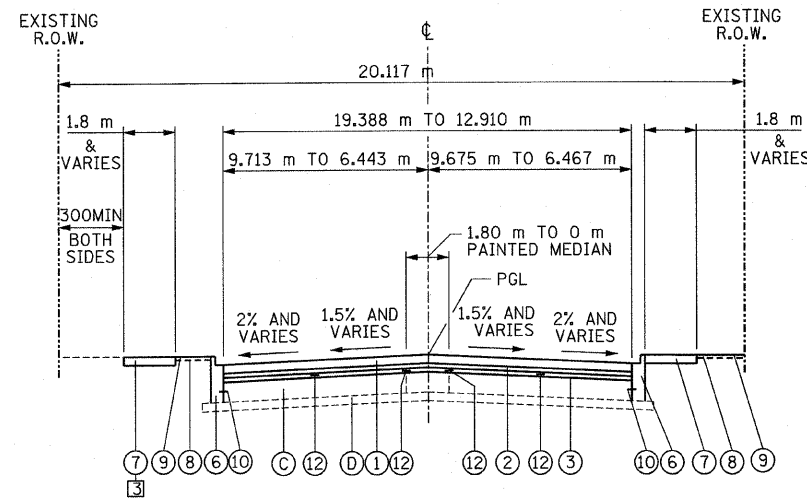

**PROPOSED TYPICAL SECTION**  
 115TH STREET  
 LOOKING EAST  
 (STA. 2+411.332 TO STA. 2+445.700 AND STA. 2+475.600 TO STA. 2+519.400)  
 BACK OF EAST ABUTMENT STA. 2+411.426  
 3 PORTLAND CEMENT CONCRETE SIDEWALK EXTENDS TO STA. 2+538.812

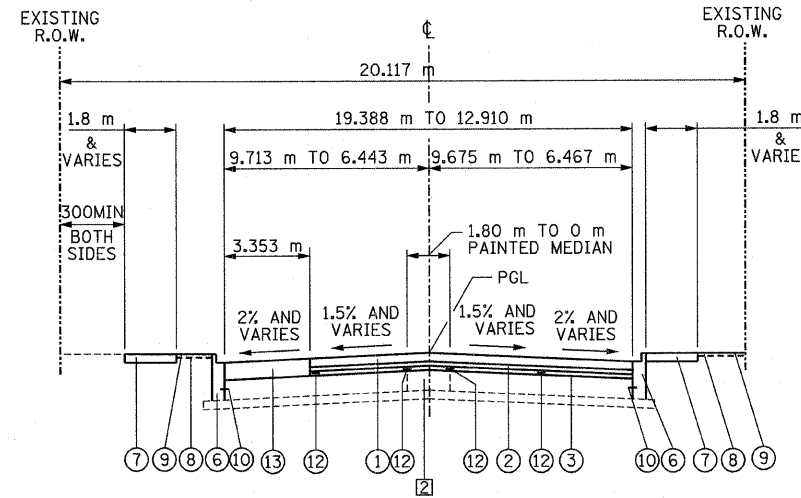

**PROPOSED TYPICAL SECTION**  
 115TH STREET  
 LOOKING EAST  
 (STA. 2+445.700 TO STA. 2+475.600)  
 BACK OF EAST ABUTMENT STA. 2+411.426  
 2 STA. 2+445.700 TO 2+475.600

**PROPOSED TYPICAL SECTION LEGEND**

- 1 HOT-MIX ASPHALT SURFACE COURSE, MIX "D", N70, 38
  - 2 HOT-MIX ASPHALT BINDER COURSE, IL19.0, N70 (57 TO 206) (WHERE REQUIRED DUE TO RAISE IN PROFILE)
  - 3 LEVELING BINDER (MACHINE METHOD), N70 (19 TO 57)
  - 4 PORTLAND CEMENT CONCRETE BASE COURSE, 230
  - 5 SUBBASE GRANULAR MATERIAL, TYPE B, 100
  - 6 COMBINATION CONCRETE C & G, TYPE B-15.30
  - 7 PORTLAND CEMENT CONCRETE SIDEWALK, 125
  - 8 TOPSOIL FURNISH AND PLACE, 100 - AS REQUIRED
  - 9 SODDING, SALT TOLERANT - AS REQUIRED
  - 10 NO. 25 EPOXY COATED DEFORMED TIE BARS @ 600 mm C-C, 600 mm LONG, DRILLED AND GROUTED (WHERE REQUIRED). COST INCLUDED IN COMB. CONC. C & G, TYPE B-15.30
  - 11 NO. 25 EPOXY COATED DEFORMED TIE BARS @ 600 mm C-C, 600 mm LONG, DRILLED AND GROUTED (WHERE REQUIRED). COST INCLUDED IN PORTLAND CEMENT CONC. BASE COURSE, 230
  - 12 STRIP REFLECTIVE CRACK CONTROL TREATMENT (SEE NOTE 1)
  - 13 PORTLAND CONCRETE CEMENT PAVEMENT, 260 mm
- PROPOSED ITEM  
 EXISTING ITEM

FOR NOTES SEE SHEET NUMBER 9

HOT-MIX ASPHALT REQUIREMENTS	AC TYPE	VOIDS	MAX RAP
HOT-MIX ASPHALT SURFACE COURSE, MIX "D", N70	PG 64-22	4% @ 70 GYR.	10% / 15%
HOT-MIX BINDER COURSE, IL-19.0, N70	PG 64-22/ PG 58-22	4% @ 70 GYR.	15% / 25%
LEVELING BINDER (MACHINE METHOD), N70	PG 64-22/ PG 58-22	4% @ 70 GYR.	15% / 25%
HOT-MIX ASPHALT REPLACEMENT OVER PATCHES	PG 64-22/ PG 58-22	4% @ 70 GYR.	15% / 25%

- NOTES:
- THE UNIT WEIGHT USED TO CALCULATE ALL HOT-MIX ASPHALT SURFACE MIXTURES IS 2.4 KG/M<sup>2</sup>/MM.
  - WHEN RAP EXCEEDS 20%, THE NEW ASPHALT BINDER IN THE MIX SHALL BE PG 58-22.

**COLLINS ENGINEERS**  
 123 North Wacker Drive  
 Suite 309  
 Chicago, IL 60606  
 (312) 704-9300  
 www.collinseng.com  
 ILLINOIS PROFESSIONAL DESIGN FIRM LICENSE NO. 184-000993

REVISIONS		ILLINOIS DEPARTMENT OF TRANSPORTATION
NAME	DATE	
		<b>TYPICAL SECTIONS</b>  <b>115TH STREET OVER I-57</b>  DRAWN BY: PRH CHECKED BY: JMH DATE: JANUARY 16, 2009

FILE: g:\2904\civil\exhib1\290400.dgn  
 DATE: 13-Jan-09 14:24

F.A.I.	SECTION	COUNTY	TOTAL SHEETS	SHEET NO.
57	1919.2B	COOK	119	11
FED. ROAD DIST. NO.		ILLINOIS	FED. AID PROJECT	

CONTRACT 60371

TEMPORARY FENCE					LENGTH (METER)
STA	OFFSET	STA	OFFSET		
115 TH STREET					
2+266.9	LT	2+280.8	LT		14.0
2+285.6	LT	2+327.3	LT		49.9
2+280.8	RT	2+327.9	RT		70.8
2+344.6	RT	2+355.3	RT		10.7
2+345.3	LT	2+356.5	LT		11.8
2+410.1	LT	2+421.1	LT		11.1
2+410.0	RT	2+421.3	RT		11.3
2+435.5	LT	2+439.6	LT		4.1
2+442.0	LT	2+454.7	LT		21.5
2+459.1	LT	2+463.8	LT		4.5
2+474.0	LT	2+538.8	LT		64.9
2+437.4	RT	2+442.3	RT		5.5
2+444.2	RT	2+455.4	RT		21.8
2+460.9	RT	2+468.1	RT		7.1
2+473.7	RT	2+520.7	RT		46.9
2+414.5	RT	2+414.5	RT		40.0
2+415.7	LT	2+415.7	LT		40.0
TOTAL =					436

SUPPLEMENTAL WATERING											
STA	OFFSET	OFFSET	STA	OFFSET	OFFSET	AREA (SQ. M)	VOLUME (1000 L)				
115 TH STREET											
2+266.8	6.37	LT	8.68	LT	2+278.4	6.78	LT	8.49	LT	22.36	1.01
2+287.3	7.15	LT	8.38	LT	2+309.8	8.10	LT	8.57	LT	19.73	0.89
2+435.5	11.74	LT	15.85	LT	2+439.7	11.74	LT	17.60	LT	19.51	0.88
2+441.3	8.14	LT	9.20	LT	2+454.0	7.18	LT	8.81	LT	15.98	0.72
2+459.5	7.71	LT	8.65	LT	2+463.6	7.24	LT	8.52	LT	3.63	0.16
2+474.3	7.79	LT	8.21	LT	2+519.3	6.95	LT	8.12	LT	33.56	1.51
2+519.3	6.95	LT	8.12	LT	2+528.8	6.76	LT	8.19	LT	12.30	0.55
2+529.8	6.79	LT	8.19	LT	2+536.4	6.81	LT	8.19	LT	8.96	0.40
2+537.4	6.80	LT	8.19	LT	2+538.9	6.80	LT	8.19	LT	2.15	0.10
2+537.5	14.90	RT	20.44	RT	2+542.2	14.90	RT	20.44	RT	25.20	1.13
TOTAL =										7	

EARTH EXCAVATION			VOLUME (CU. M)
STA	STA		
115 TH STREET			
2+261.0	2+519.4		65.0
TOTAL =			65

TOPSOIL FURNISH AND PLACE, 100MM										
STA	OFFSET	OFFSET	STA	OFFSET	OFFSET	AREA (SQ. M)				
115 TH STREET										
2+266.8	6.37	LT	8.68	LT	2+278.4	6.78	LT	8.49	LT	17.9
2+287.3	7.15	LT	8.38	LT	2+309.8	8.10	LT	8.57	LT	9.3
2+435.5	11.74	LT	15.85	LT	2+439.7	11.74	LT	17.60	LT	17.5
2+441.3	8.14	LT	9.20	LT	2+454.0	7.18	LT	8.81	LT	10.4
2+459.5	7.71	LT	8.65	LT	2+463.6	7.24	LT	8.52	LT	1.8
2+474.3	7.79	LT	8.21	LT	2+519.3	6.95	LT	8.12	LT	13.0
2+519.3	6.95	LT	8.12	LT	2+528.8	6.76	LT	8.19	LT	12.3
2+529.8	6.79	LT	8.19	LT	2+536.4	6.81	LT	8.19	LT	9.0
2+537.4	6.80	LT	8.19	LT	2+538.9	6.80	LT	8.19	LT	2.2
2+537.5	14.90	RT	20.44	RT	2+542.2	14.90	RT	20.44	RT	22.7
2+499.5	8.00	RT	8.50	RT	2+520.5	7.50	RT	8.50	RT	15.8
TOTAL =										132

SEEDING, CLASS 2A											
STA	OFFSET	OFFSET	STA	OFFSET	OFFSET	AREA	HECTARE				
115 TH STREET											
2+344.8	12.58	LT	22.82	LT	2+356.6	12.53	LT	22.79	LT	119.18	0.0119
2+344.6	12.57	RT	16.5	RT	2+355.5	12.26	RT	16.6	RT	43.7	0.0044
2+410.1	12.31	LT	20.18	LT	2+421.2	12.11	LT	20.19	LT	85.53	0.0086
2+410.0	12.51	RT	19.95	RT	2+421.5	12.55	RT	19.97	RT	84.84	0.0085
TOTAL =										0.1	

NITROGEN FERTILIZER NUTRIENT											
STA	OFFSET	OFFSET	STA	OFFSET	OFFSET	AREA	KG				
SEEDING											
2+344.8	12.58	LT	22.82	LT	2+356.6	12.53	LT	22.79	LT	119.18	1.19
2+344.6	12.57	RT	16.5	RT	2+355.5	12.26	RT	16.6	RT	43.70	0.44
2+410.1	12.31	LT	20.18	LT	2+421.2	12.11	LT	20.19	LT	85.53	0.86
2+410.0	12.51	RT	19.95	RT	2+421.5	12.55	RT	19.97	RT	84.84	0.85
SODDING											
2+266.8	6.37	LT	8.68	LT	2+278.4	6.78	LT	8.49	LT	22.36	0.16
2+287.3	7.15	LT	8.38	LT	2+309.8	8.10	LT	8.57	LT	19.73	0.14
2+435.5	11.74	LT	15.85	LT	2+439.7	11.74	LT	17.60	LT	19.51	0.14
2+441.3	8.14	LT	9.20	LT	2+454.0	7.18	LT	8.81	LT	15.98	0.11
2+459.5	7.71	LT	8.65	LT	2+463.6	7.24	LT	8.52	LT	3.63	0.03
2+474.3	7.79	LT	8.21	LT	2+519.3	6.95	LT	8.12	LT	33.56	0.23
2+519.3	6.95	LT	8.12	LT	2+528.8	6.76	LT	8.19	LT	12.30	0.09
2+529.8	6.79	LT	8.19	LT	2+536.4	6.81	LT	8.19	LT	8.96	0.06
2+537.4	6.80	LT	8.19	LT	2+538.9	6.80	LT	8.19	LT	2.15	0.02
2+537.5	14.90	RT	20.44	RT	2+542.2	14.90	RT	20.44	RT	25.20	0.18
TOTAL =										4	

PHOSPHORUS FERTILIZER NUTRIENT											
STA	OFFSET	OFFSET	STA	OFFSET	OFFSET	AREA	KG				
SEEDING											
2+344.8	12.58	LT	22.82	LT	2+356.6	12.53	LT	22.79	LT	119.18	1.19
2+344.6	12.57	RT	16.5	RT	2+355.5	12.26	RT	16.6	RT	43.70	0.44
2+410.1	12.31	LT	20.18	LT	2+421.2	12.11	LT	20.19	LT	85.53	0.86
2+410.0	12.51	RT	19.95	RT	2+421.5	12.55	RT	19.97	RT	84.84	0.85
SODDING											
2+266.8	6.37	LT	8.68	LT	2+278.4	6.78	LT	8.49	LT	22.36	0.16
2+287.3	7.15	LT	8.38	LT	2+309.8	8.10	LT	8.57	LT	19.73	0.14
2+435.5	11.74	LT	15.85	LT	2+439.7	11.74	LT	17.60	LT	19.51	0.14
2+441.3	8.14	LT	9.20	LT	2+454.0	7.18	LT	8.81	LT	15.98	0.11
2+459.5	7.71	LT	8.65	LT	2+463.6	7.24	LT	8.52	LT	3.63	0.03
2+474.3	7.79	LT	8.21	LT	2+519.3	6.95	LT	8.12	LT	33.56	0.23
2+519.3	6.95	LT	8.12	LT	2+528.8	6.76	LT	8.19	LT	12.30	0.09
2+529.8	6.79	LT	8.19	LT	2+536.4	6.81	LT	8.19	LT	8.96	0.06
2+537.4	6.80	LT	8.19	LT	2+538.9	6.80	LT	8.19	LT	2.15	0.02
2+537.5	14.90	RT	20.44	RT	2+542.2	14.90	RT	20.44	RT	25.20	0.18
TOTAL =										4	

POTASSIUM FERTILIZER NUTRIENT											
STA	OFFSET	OFFSET	STA	OFFSET	OFFSET	AREA	KG				
SEEDING											
2+344.8	12.58	LT	22.82	LT	2+356.6	12.53	LT	22.79	LT	119.18	1.19
2+344.6	12.57	RT	16.5	RT	2+355.5	12.26	RT	16.6	RT	43.70	0.44
2+410.1	12.31	LT	20.18	LT	2+421.2	12.11	LT	20.19	LT	85.53	0.86
2+410.0	12.51	RT	19.95	RT	2+421.5	12.55	RT	19.97	RT	84.84	0.85
SODDING											
2+266.8	6.37	LT	8.68	LT	2+278.4	6.78	LT	8.49	LT	22.36	0.16
2+287.3	7.15	LT	8.38	LT	2+309.8	8.10	LT	8.57	LT	19.73	0.14
2+435.5	11.74	LT	15.85	LT	2+439.7	11.74	LT	17.60	LT	19.51	0.14
2+441.3	8.14	LT	9.20	LT	2+454.0	7.18	LT	8.81	LT	15.98	0.11
2+459.5	7.71	LT	8.65	LT	2+463.6	7.24	LT	8.52	LT	3.63	0.03
2+474.3	7.79	LT	8.21	LT	2+519.3	6.95	LT	8.12	LT	33.56	0.23
2+519.3	6.95	LT	8.12	LT	2+528.8	6.76	LT	8.19	LT	12.30	0.09
2+529.8	6.79	LT	8.19	LT	2+536.4	6.81	LT	8.19	LT	8.96	0.06
2+537.4	6.80	LT	8.19	LT	2+538.9	6.80	LT	8.19	LT	2.15	0.02
2+537.5	14.90	RT	20.44	RT	2+542.2	14.90	RT	20.44	RT	25.20	0.18
TOTAL =										4	

EROSION CONTROL BLANKET										
STA	OFFSET	OFFSET	STA	OFFSET	OFFSET	AREA (SQ. M)				
115 TH STREET										
2+344.8	12.58	LT	22.82	LT	2+356.6	12.53	LT	22.79	LT	119.18
2+344.6	12.57	RT	16.5	RT	2+355.5	12.26	RT	16.6	RT	43.7
2+410.1	12.31	LT	20.18	LT	2+421.2	12.11	LT	20.19	LT	85.53
2+410.0	12.51	RT	19.95	RT	2+421.5	12.55	RT	19.97	RT	84.84
TOTAL =										333

SODDING, SALT TOLERANT										
STA	OFFSET	OFFSET	STA	OFFSET	OFFSET	AREA (SQ. M)				
115 TH STREET										
2+266.8	6.37	LT	8.68	LT	2+278.4	6.78	LT	8.49	LT	17.86
2+287.3	7.15	LT	8.38	LT	2+309.8	8.10	LT	8.57	LT	9.29
2+435.5	11.74	LT	15.85	LT	2+439.7	11.74	LT	17.60	LT	17.52
2+441.3	8.14	LT	9.20	LT	2+454.0	7.18	LT	8.81	LT	10.35
2+459.5	7.7									

F.A.I.	SECTION	COUNTY	TOTAL SHEETS	SHEET NO.
57	1919.2B	COOK	119	12
FED. ROAD DIST. NO.			ILLINOIS FED. AID PROJECT	

CONTRACT 60371

PORTLAND CEMENT CONCRETE BASE COURSE, 230 MM					AREA (SQ M)
STA	OFFSET	STA	OFFSET		
115 TH STREET					
2+321.4	8.12	LT	2+330.8	18.74	LT
TOTAL					12

BITUMINOUS MATERIALS (PRIME COAT)					AREA	M TON
STATION	STATION					
115 TH STREET						
2+261.00	2+345.50				1304.40	0.62
2+420.33	2+519.40				1569.82	0.75
MARSHFIELD AVENUE						
4+115.00	4+124.44				137.53	0.07
4+139.54	4+155.00				199.42	0.09
ASHLAND AVENUE						
6+112.22	6+124.58				197.17	0.09
6+139.60	6+152.66				181.13	0.09
TOTAL						2

AGGREGATE (PRIME COAT)					AREA	M TON
STATION	STATION					
115 TH STREET						
2+261.00	2+345.50				1304.40	3.91
2+420.33	2+519.00				1569.82	4.71
MARSHFIELD AVENUE						
4+115.00	4+124.44				137.53	0.41
4+139.54	4+155.00				199.42	0.80
ASHLAND AVENUE						
6+112.22	6+124.58				197.17	0.59
6+139.60	6+152.66				181.13	0.54
TOTAL						11

HOT-MIX ASPHALT SURFACE REMOVAL - BUTT JOINT							AREA (SQ M)
STA	OFFSET	OFFSET	STA	OFFSET	OFFSET		
115 TH STREET							
2+261.0	5.89	LT	6.35	RT	2+262.4	5.89	LT
2+518.1	6.44	LT	6.47	RT	2+519.4	6.44	LT
MARSHFIELD AVENUE							
4+115.0	5.53	RT	5.58	LT	4+116.4	5.53	RT
4+153.7	5.46	RT	5.36	LT	4+155.0	5.46	RT
ASHLAND AVENUE							
6+112.2	5.51	LT	7.95	RT	6+113.6	5.51	LT
6+151.3	5.53	RT	6.22	LT	6+152.7	5.48	RT
TOTAL							98

LEVELING BINDER (MACHINE METHOD), N70					AREA	M TON
STATION	STATION					
115 TH STREET						
2+261.00	2+345.50				1304.40	78.00
2+420.33	2+519.40				1569.82	93.88
MARSHFIELD AVENUE						
4+115.00	4+124.44				137.53	8.22
4+139.54	4+155.00				199.42	11.93
ASHLAND AVENUE						
6+112.00	6+124.58				197.17	11.79
6+139.60	6+152.50				181.13	10.83
TOTAL						215

HOT-MIX ASPHALT BINDER COURSE, IL-19.0, N70					AREA (SQ M)	M TON
STA	STA					
115 TH STREET						
2+321.7	2+331.8				932.9	133.9
2+420.3	2+436.0				623.5	89.5
TOTAL						223

HOT-MIX ASPHALT SURFACE COURSE, MIX "D", N70					AREA	M TON
STATION	STATION					
115 TH STREET						
2+261.00	2+345.50				1304.40	118.56
2+420.33	2+519.40				1569.82	142.69
MARSHFIELD AVENUE						
4+115.00	4+124.44				137.53	12.50
4+139.54	4+155.00				220.12	20.01
ASHLAND AVENUE						
6+112.00	6+124.58				197.17	17.92
6+139.60	6+152.66				181.13	16.46
TOTAL						328

PORTLAND CEMENT CONCRETE PAVEMENT 280MM							AREA
STA	OFFSET	OFFSET	STA	OFFSET	OFFSET		
115 STREET							
2+445.713	7.2	LT	4.6	LT	2+476.193	7.2	LT
TOTAL							103

PORTLAND CEMENT CONCRETE DRIVEWAY PAVEMENT, 200MM										AVG WIDTH	AREA (SQ M)
STA	OFFSET	OFFSET	STA	OFFSET	OFFSET						
115 TH STREET											
2+279.7	6.84	LT	9.95	LT	2+287.3	7.15	LT	9.98	LT	2.97	22.57
2+453.3	7.18	LT	10.46	LT	2+459.8	7.22	LT	10.59	LT	3.325	21.61
2+463.6	7.24	LT	10.32	LT	2+474.3	7.31	LT	9.94	LT	2.855	30.55
2+467.7	7.54	RT	9.83	RT	2+473.6	7.54	RT	9.83	RT	2.29	13.51
ASHLAND AVENUE											
6+147.9	6.09	RT	10.34	RT	6+152.5	5.97	RT	10.15	RT	4.215	19.46
TOTAL											108

PORTLAND CEMENT CONCRETE SIDEWALK 125MM							AREA (SQ M)
STATION	OFFSET	OFFSET	STATION	OFFSET	OFFSET		
115 TH STREET							
2+266.8	8.68	LT	10.18	LT	2+280.9	6.84	LT
2+285.7	8.38	LT	9.98	LT	2+331.0	19.84	LT
2+261.0	6.35	RT	8.63	RT	2+329.2	16.67	RT
2+343.1	12.72	LT	22.83	LT	2+345.6	10.15	LT
2+419.2	10.15	LT	11.81	LT	2+422.9	12.54	LT
2+420.1	10.15	RT	12.20	RT	2+423.1	12.71	RT
2+436.8	11.52	LT	11.52	LT	2+454.7	8.81	LT
2+459.1	8.65	LT	10.46	LT	2+463.8	8.52	LT
2+474.2	8.21	LT	9.94	LT	2+538.9	8.20	LT
2+437.7	14.90	RT	14.90	RT	2+467.9	8.02	RT
2+473.8	8.02	RT	9.79	RT	2+520.8	6.90	RT
TOTAL							659

PAVEMENT REMOVAL							AREA (SQ M)
STA	OFFSET	OFFSET	STA	OFFSET	OFFSET		
115 TH STREET							
2+343.7	9.8	LT	9.7	RT	2+348.4	9.8	LT
2+417.5	9.7	LT	9.7	RT	2+422.2	9.7	LT
2+445.7	7.2	LT	3.8	LT	2+476.2	7.2	LT
TOTAL							285

HOT-MIX ASPHALT SURFACE REMOVAL, 60MM										AREA (SQ M)
STATION	OFFSET	OFFSET	STATION	OFFSET	OFFSET					
115 TH STREET										
2+262.4	6.35	RT	5.89	LT	2+346.4	7.16	RT	8.12	LT	1191.66
2+419.2	7.59	RT	7.34	LT	2+518.1	6.47	RT	6.44	LT	1431.95
MARSHFIELD AVENUE										
4+116.4	5.55	RT	5.69	LT	4+123.5	9.66	RT	14.97	LT	121.50
4+140.4	9.54	RT	14.81	LT	4+153.7	5.53	RT	5.36	LT	179.66
ASHLAND AVENUE										
6+113.4	7.87	RT	5.68	LT	6+124.4	17.01	RT	10.18	LT	178.65
6+139.5	13.90	RT	10.21	LT	6+151.2	5.62	RT	6.18	LT	168.49
TOTAL										3272

DRIVEWAY PAVEMENT REMOVAL										AVG WIDTH	AREA (SQ M)
STA	OFFSET	OFFSET	STA	OFFSET	OFFSET						
115 TH STREET											
2+279.7	6.84	LT	9.95	LT	2+287.3	7.15	LT	9.98	LT	2.97	22.57
2+453.3	7.18	LT	10.46	LT	2+459.8	7.22	LT	10.59	LT	3.325	21.61
2+463.6	7.24	LT	10.32	LT	2+474.3	7.31	LT	9.94	LT	2.855	30.55
2+467.7	7.54	RT	9.83	RT	2+473.6	7.54	RT	9.83	RT	2.29	13.51
ASHLAND AVENUE											
6+147.9	6.09	RT	10.32	RT	6+152.5	5.97	RT	10.15	RT	4.205	19.34
TOTAL											108

COMBINATION CURB AND GUTTER REMOVAL				LENGTH (METER)
STA	STA			
115 TH STREET				
2+261.0	LT	2+329.0	LT	68.0
2+261.0	RT	2+327.6	RT	66.6
2+344.2	LT	2+354.4	LT	10.2
2+343.8	RT	2+354.4	RT	10.7
2+411.4	LT	2+421.1	LT	9.7
2+438.2	LT	2+519.4	LT	81.2
2+411.4	RT	2+421.9	RT	10.5
2+439.8	RT	2+519.4	RT	79.6
MARSHFIELD AVENUE				
4+115.0	LT	4+124.4	LT	9.4
4+115.0	RT	4+120.9	RT	5.9
4+143.9	LT	4+155.0	LT	11.1
4+142.4	RT	4+155.0	RT	12.6
ASHLAND AVENUE				
6+112.2	LT	6+121.8	LT	9.6
6+112.2	RT	6+121.8	RT	9.6
6+142.1	LT	6+152.7	LT	10.6
6+141.5	RT	6+152.7	RT	11.2
TOTAL				416

CONCRETE CURB, TYPE B				TOT LENGTH M
STA	OFFSET			
115 STREET				
2+345	12.0	LT		3.00
2+345	12.0	RT		3.00
2+421	12.0	LT		3.00
2+421	12.0	RT		3.00
2+440	11.0	LT		8.00
TOTAL				20

REVISIONS	
NAME	DATE

ILLINOIS DEPARTMENT OF TRANSPORTATION  
 SCHEDULE OF QUANTITIES  
 DRAWN BY: PRH  
 CHECKED BY: JMH  
 DATE: JANUARY 16, 2009

**COLLINS ENGINEERS**  
 123 North Wacker Drive  
 Suite 300  
 Chicago, IL 60606  
 (312) 704-9300  
 www.collinsengr.com  
 ILLINOIS PROFESSIONAL DESIGN FIRM LICENSE NO. 184-000993

FILE: g:\2904\civil\exhibit\2904012.dgn  
 DATE: 19-Nov-07 14:47

COMBINATION CONCRETE CURB AND GUTTER, TYPE B-15.30

STA	STA	LENGTH (METER)
115 TH STREET		
2+261.0 LT	2+317.5 LT	56.5
2+261.0 RT	2+322.1 RT	61.1
2+346.0 LT	2+348.5 LT	2.5
2+345.7 RT	2+348.5 RT	2.8
2+417.4 LT	2+419.8 LT	2.4
2+417.4 RT	2+420.4 RT	3.0
2+443.2 LT	2+519.0 LT	76.3
2+446.5 RT	2+479.1 RT	32.8
2+479.1 RT	2+519.0 RT	40.3
MARSHFIELD AVENUE		
4+115.0 LT	4+124.4 LT	14.8
4+115.0 RT	4+119.0 RT	4.0
4+119.0 RT	4+121.9 RT	4.8
4+139.5 LT	4+155.0 LT	22.2
4+141.3 RT	4+144.3 RT	4.8
4+144.3 RT	4+155.0 RT	10.1
ASHLAND AVENUE		
6+112.0 LT	6+119.3 LT	7.3
6+112.0 RT	6+115.3 RT	3.3
6+119.3 LT	6+122.5 LT	4.8
6+115.3 RT	6+124.7 RT	14.5
6+141.5 LT	6+144.5 LT	4.6
6+140.0 RT	6+148.3 RT	13.0
6+144.5 LT	6+152.5 LT	7.7
6+148.3 RT	6+152.5 RT	4.3
TOTAL	=	398

SHORT-TERM PAVEMENT MARKING

STA	OFFSET	STA	OFFSET	LENGTH M	LINE TYPE	TOT LENGTH M
100 MM						
115TH STREET						
2+134.0	3.20	RT	2+322.0	3.90	RT	188.00 SKIP/DASH 18.80
2+261.0	0.00		2+324.1	0.00		63.10 DBL YELLOW 6.31
2+291.7	0.00		2+324.1	0.00		32.40 DBL YELLOW 3.24
2+257.8	2.90	LT	2+322.0	4.50	LT	64.20 SKIP/DASH 6.42
2+443.5	4.10	RT	2+649.0	3.05	RT	205.50 SKIP/DASH 20.55
2+443.5	4.10	LT	2+649.0	3.05	LT	205.50 SKIP/DASH 20.55
2+442.2	0.00		2+511.7	0.00		69.50 DBL YELLOW 6.95
2+442.2	0.00		2+649.0	0.00		206.80 DBL YELLOW 20.68
2+349.0	5.02	LT	2+416.5	4.99	LT	67.50 SKIP/DASH 6.75
2+349.0	4.93	RT	2+416.5	4.93	RT	67.50 SKIP/DASH 6.75
2+351.0	1.39	RT	2+412.0	1.39	LT	61.50 DBL YELLOW 6.15
2+343.7	8.25	LT	2+422.1	8.25	LT	78.40 SOLID WHITE 7.84
2+343.7	8.25	RT	2+422.1	8.25	RT	78.40 SOLID WHITE 7.84
MARSHFIELD AVENUE						
4+115.0	1.90	RT	4+120.0	1.90	RT	5.00 SKIP/DASH 0.50
4+115.0	1.90	LT	4+120.0	1.90	LT	5.00 SKIP/DASH 0.50
4+144.0	1.70	LT	4+215.0	1.70	LT	71.00 SKIP/DASH 7.10
4+142.0	1.90	RT	4+209.3	5.50	RT	67.30 SOLID WHITE 6.73
ASHLAND AVENUE						
6+076.6	1.25	LT	6+117.5	1.95	LT	40.90 SKIP/DASH 4.09
6+076.6	2.35	RT	6+117.5	1.65	RT	40.90 SKIP/DASH 4.09
6+144.0	1.56	LT	6+152.7	1.82	LT	8.66 SKIP/DASH 0.87
6+144.0	2.04	RT	6+152.7	1.78	RT	8.66 SKIP/DASH 0.87
6+085.2	8.29	RT	6+118.9	7.09	RT	33.70 SOLID WHITE 3.37
150 MM						
115TH STREET						
2+349.0	1.66	LT	2+370.5	1.66	LT	21.50 SOLID WHITE 2.15
2+391.5	1.67	RT	2+416.5	1.67	RT	25.00 SOLID WHITE 2.50
2+370.5	1.66	LT	2+390.5	1.66	LT	20.00 DOTTED 2.00
2+371.5	1.67	RT	2+391.5	1.67	RT	20.00 DOTTED 2.00
TOTAL	=					176

TEMPORARY PAVEMENT MARKING - LETTERS AND SYMBOLS

STA	OFFSET	LETTER	TOT AREA SQ M
STAGE I			
115TH STREET			
2+358.7		RT	LT ARROW 1.47
2+366.5		RT	ONLY 2.13
2+399.0		RT	ONLY 2.13
2+407.1		RT	LT ARROW 1.47
2+272.5		RT	R 0.33
2+272.5		LT	R 0.33
TOTAL	=		8

TEMPORARY PAVEMENT MARKING - LINE 100 MM

STA	OFFSET	STA	OFFSET	LENGTH M	LINE TYPE	TOT LENGTH M
STAGE I						
115TH STREET						
2+261.0	2.80	LT	2+330.0	2.30	LT	69.00 SOLID WHITE 69.00
2+341.0	2.00	LT	2+426.0	2.00	LT	85.00 SOLID WHITE 85.00
2+437.0	2.00	LT	2+519.4	0.00		82.42 SOLID WHITE 82.42
2+346.0	6.70	RT	2+419.5	3.66	RT	73.56 DBL YELLOW 147.13
2+446.5	4.40	RT	2+519.4	4.10	RT	72.90 DBL YELLOW 145.80
2+261.0	0.30	RT	2+315.0	3.67	RT	47.11 SOLID YELLOW 47.11
2+261.0	3.30	RT	2+315.0	3.67	RT	47.00 SOLID YELLOW 47.00
2+315.0	3.65	RT	2+346.0	4.22	RT	31.01 DOTTED 7.75
2+419.5	3.70	RT	2+446.5	4.18	RT	27.00 DOTTED 6.75
MARSHFIELD AVENUE						
4+134.0	7.34	LT	4+155.0	5.40	LT	21.09 SOLID WHITE 21.09
4+146.0	1.78	LT	4+155.0	1.78	LT	9.00 SKIP/DASH 2.22
4+134.0	3.90	RT	4+155.0	2.00	RT	21.09 SOLID YELLOW 21.09
ASHLAND AVENUE						
6+134.0	7.34	RT	6+152.7	5.50	RT	18.75 SOLID WHITE 18.75
6+112.2	3.72	RT	6+119.0	3.72	RT	6.78 SKIP/DASH 1.67
6+112.2	0.50	RT	6+119.0	0.60	RT	6.78 SOLID YELLOW 6.78
6+134.0	3.16	LT	6+152.7	0.60	LT	18.83 SOLID YELLOW 18.83
6+112.2	0.50	RT	6+119.0	0.50	RT	6.78 SOLID WHITE 6.78
6+112.2	2.50	LT	6+119.0	2.50	LT	6.78 SKIP/DASH 1.67
STAGE II						
115 TH STREET						
2+261.0	3.30	RT	2+327.0	0.00		70.00 SOLID WHITE 70.00
2+442.0	0.00		2+519.4	0.00		84.00 SOLID WHITE 84.00
MARSHFIELD AVENUE						
4+115.0	5.60	LT	4+132.0	9.50	LT	17.44 SOLID WHITE 17.44
4+115.0	0.20	RT	4+132.0	4.00	RT	17.42 SOLID YELLOW 17.42
ASHLAND AVENUE						
6+112.2	7.70	RT	6+130.0	11.30	RT	18.14 SOLID WHITE 18.14
6+112.2	0.00		6+130.0	4.50	LT	18.34 SOLID YELLOW 18.34
6+112.2	3.75	RT	6+119.0	3.75	RT	6.78 SKIP/DASH 1.67
TOTAL	=					964

TEMPORARY PAVEMENT MARKING - LINE 150 MM

STA	OFFSET	STA	OFFSET	LENGTH M	LINE TYPE	TOT LENGTH M
STAGE I						
115TH STREET						
2+346.0	3.65	RT	2+370.0	3.65		24.00 SOLID WHITE 24.00
2+370.0	3.65	RT	2+395.0	3.65		25.00 SKIP/DASH 6.25
2+370.0	6.71	RT	2+395.0	6.71		25.00 SKIP/DASH 6.25
2+395.0	6.71	RT	2+419.5	6.71		24.50 SOLID WHITE 24.50
TOTAL	=					61

TEMPORARY PAVEMENT MARKING - LINE 400 MM

STA	OFFSET	STA	OFFSET	LENGTH M	LINE TYPE	TOT LENGTH M
115TH STREET						
2270.2	1.5	LT	2276.1	0.6	RT	6.2 SOLID WHITE 6.2
2270.2	0.6	RT	2276.1	1.5	LT	6.2 SOLID WHITE 6.2
TOTAL	=					12

WET TEMPORARY PAVEMENT MARKING TAPE, TYPE III - LETTERS AND SYMBOLS

STA	OFFSET	LETTER	TOT AREA SQ M
STAGE II & STAGE III			
115TH STREET			
2+280.7		LT	R 0.33
2+280.7		LT	R 0.33
2+359.8		LT	LT ARROW 1.47
2+367.2		LT	ONLY 2.13
2+399.0		LT	ONLY 2.13
2+407.0		LT	LT ARROW 1.47
STAGE III			
115 TH STREET			
2+397.9		RT	ONLY 2.13
2+404.9		RT	LT ARROW 1.47
TOTAL	=		11

TEMPORARY PAVEMENT MARKING - LINE 600 MM

STA	OFFSET	STA	OFFSET	LENGTH M	LINE TYPE	TOT LENGTH M
STAGE I-A						
115 TH STREET						
2+264.9	2.55	LT	0.50	RT	3.05 SOLID WHITE 3.05	
2+280.0	1.60	LT	1.45	RT	3.05 SOLID WHITE 3.05	
2+315.0	3.95	RT	7.00	RT	3.05 SOLID WHITE 3.05	
2+346.0	0.60	RT	3.70	RT	3.10 SOLID WHITE 3.10	
2+350.0	3.70	RT	6.80	RT	3.10 SOLID WHITE 3.10	
2+415.0	3.66	RT	6.76	RT	3.10 SOLID WHITE 3.10	
2+419.5	6.76	RT	9.86	RT	3.10 SOLID WHITE 3.10	
2+446.5	1.31	RT	4.36	RT	3.05 SOLID WHITE 3.05	
MARSHFIELD AVENUE						
4+146.0	5.10	LT	1.00	RT	6.10 SOLID WHITE 6.10	
ASHLAND AVENUE						
6+119.0	0.20	RT	7.50	RT	7.30 SOLID WHITE 7.30	
STAGE I-B						
115 TH STREET						
2+349.0	0.00		3.10	RT	3.10 SOLID WHITE 3.10	
2+353.0	3.10	RT	6.20	RT	3.10 SOLID WHITE 3.10	
ASHLAND AVENUE						
6+119.0	6.60	RT	0.50	RT	6.10 SOLID WHITE 6.10	
TOTAL	=					50

WET TEMPORARY PAVEMENT MARKING TAPE, TYPE III (LINE 150 MM)

STA	OFFSET	STA	OFFSET	LENGTH M	LINE TYPE	TOT LENGTH M
STAGE II						
115TH STREET						
2+346.0	6.55	LT	2+370.0	6.55	LT	24.00 SOLID WHITE 24.00
2+370.0	6.55	LT	2+395.0	6.55	LT	25.00 SKIP/DASH 6.25
2+370.0	3.50	LT	2+395.0	3.50	LT	25.00 SKIP/DASH 6.25
2+395.0	3.50	LT	2+419.5	3.50	LT	24.50 SOLID WHITE 24.50
TOTAL	=					122

WET TEMPORARY PAVEMENT MARKING TAPE, TYPE III (LINE 300 MM)

STA	OFFSET	STA	OFFSET	LENGTH M	LINE TYPE	TOT LENGTH M
STAGE II & STAGE III						
115TH STREET						
2+277.5	3.75	LT	2+283.9	6.38	LT	6.54 SOLID WHITE 6.54
2+277.5	6.16	LT	2+283.9	3.97	LT	6.54 SOLID WHITE 6.54
TOTAL	=					13

TEMPORARY CONCRETE BARRIER

STA	STA	LENGTH (METER)
115 ST STREET		
2+345.0	LT	2+423.0 LT 76.25
SHOULDER CLOSURE		
16+112.0	LT	16+204.0 LT 88.45
16+076.0	RT	16+169.0 RT 88.45
TOTAL	=	253

REVISIONS	
NAME	DATE

ILLINOIS DEPARTMENT OF TRANSPORTATION  
 SCHEDULE OF QUANTITIES  
 DRAWN BY: PRH  
 CHECKED BY: JMH  
 DATE: JANUARY 16, 2009



FILE: g:\2904\civil\exhibit\2904013.dgn  
 DATE: 19-Nov-07 14:47

F.A.I.	SECTION	COUNTY	TOTAL SHEETS	SHEET NO.
57	1919.2B	COOK	119	14
FED. ROAD DIST. NO.		ILLINOIS FED. AID PROJECT		

CONTRACT 60371

WET TEMPORARY PAVEMENT MARKING TAPE, TYPE III (LINE 100 MM)					
STA	OFFSET	STA	OFFSET	LENGTH M	TOT LENGTH M
<b>STAGE I</b>					
<b>115TH STREET</b>					
2+134.0	0.00	2+261.0	0.30	RT 91.00	SOLID YELLOW 91.00
2+134.0	0.00	2+261.0	3.30	RT 97.00	SOLID YELLOW 97.00
2+250.5	2.90	2+261.0	2.90	LT 10.50	SOLID WHITE 10.50
2+519.4	3.40	2+524.0	3.40	RT 4.75	DBLE YELLOW 9.50
2+519.4	0.40	2+637.0	6.10	LT 115.00	SOLID WHITE 115.00
2+540.0	3.00	2+615.0	0.00	59.00	SOLID YELLOW 59.00
2+540.0	3.00	2+625.0	3.20	RT 71.00	SOLID YELLOW 71.00
<b>MARSHFIELD AVENUE</b>					
4+155.0	2.00	4+235.0	5.40	RT 80.70	SOLID YELLOW 80.70
4+132.0	2.00	4+257.0	5.17	LT 116.00	SOLID WHITE 116.00
4+132.0	8.80	4+155.0	5.70	RT 26.00	SOLID YELLOW 26.00
<b>ASHLAND AVENUE</b>					
6+010.0	3.00	6+112.2	0.50	RT 102.25	SOLID YELLOW 102.25
6+010.0	8.00	6+112.2	1.00	RT 95.00	SOLID WHITE 95.00
6+132.0	8.00	6+152.7	6.50	LT 23.00	SOLID YELLOW 23.00
6+131.0	12.80	6+152.7	0.00	31.00	SOLID WHITE 31.00
<b>STAGE II</b>					
<b>115 TH STREET</b>					
2+169.0	6.00	2+261.0	3.24	RT 77.40	SOLID WHITE 77.40
2+250.0	2.90	2+318.5	4.90	LT 60.20	SOLID YELLOW 60.20
2+250.0	0.00	2+318.5	4.90	LT 56.20	SOLID YELLOW 56.20
2+318.5	5.00	2+346.0	3.45	LT 27.54	DOTTED 6.89
2+346.0	3.45	2+419.0	6.55	LT 74.00	DBLE YELLOW 148.00
2+419.0	6.55	2+443.0	4.48	LT 23.00	DOTTED 5.75
2+346.0	0.00	2+419.0	0.00	73.00	SOLID WHITE 73.00
2+443.0	4.50	2+545.0	3.13	LT 102.01	DBLE YELLOW 204.02
2+545.0	3.13	2+649.0	0.00	75.00	SOLID YELLOW 75.00
2+545.0	3.13	2+649.0	0.00	75.00	SOLID YELLOW 75.00
<b>MARSHFIELD AVENUE</b>					
4+145.5	2.00	4+235.0	5.40	RT 89.56	SOLID YELLOW 89.56
4+145.5	1.78	4+155.0	1.78	LT 9.50	SKIP/DASH 2.34
4+115.0	2.50	4+133.0	12.50	LT 29.00	SOLID WHITE 29.00
4+115.0	5.53	4+132.0	6.80	RT 17.05	SOLID YELLOW 17.05
4+145.5	2.60	4+257.0	5.20	LT 84.00	SOLID WHITE 84.00
<b>ASHLAND AVENUE</b>					
6+010.0	3.00	6+112.2	0.50	RT 102.25	SOLID YELLOW 102.25
6+010.0	8.00	6+133.0	8.50	RT 118.00	SOLID WHITE 118.00
6+120.0	5.60	6+132.0	8.00	LT 14.00	SOLID YELLOW 14.00
6+112.2	2.40	6+119.0	2.40	LT 6.78	SKIP/DASH 1.67
<b>STAGE III</b>					
<b>115 TH STREET</b>					
2+134.0	0.00	2+235.0	0.00	79.00	SOLID YELLOW 79.00
2+134.0	0.00	2+235.0	3.05	RT 84.00	SOLID YELLOW 84.00
2+250.5	2.90	2+328.0	0.00	80.00	SOLID YELLOW 80.00
2+248.5	3.00	2+328.0	0.00	83.00	SOLID YELLOW 83.00
2+346.0	0.00	2+420.0	0.00	81.00	SOLID YELLOW 81.00
2+346.0	0.00	2+420.0	0.00	81.00	SOLID YELLOW 81.00
2+441.0	0.00	2+569.0	0.00	131.00	SOLID YELLOW 131.00
2+441.0	0.00	2+569.0	0.00	131.00	SOLID YELLOW 131.00
2+569.0	0.00	2+600.0	0.00	31.00	DBLE YELLOW 62.00
2+323.0	7.50	2+334.0	8.34	RT 11.03	SOLID WHITE 11.03
2+318.0	7.95	2+335.0	9.35	LT 17.06	SOLID WHITE 17.06
2+431.0	9.23	2+446.0	7.42	RT 15.11	SOLID WHITE 15.11
2+431.0	8.86	2+443.0	7.51	LT 12.08	SOLID WHITE 12.08
<b>MARSHFIELD AVENUE</b>					
4+115.0	0.75	4+123.0	2.58	LT 8.21	SOLID WHITE 8.21
4+142.0	1.46	4+257.0	5.16	LT 99.00	SOLID WHITE 99.00
4+145.5	2.50	4+155.0	2.50	RT 9.50	SKIP/DASH 2.34
<b>ASHLAND AVENUE</b>					
6+010.0	8.04	6+123.0	2.95	RT 108.00	SOLID WHITE 108.00
6+142.0	1.75	6+152.7	0.00	10.80	SOLID WHITE 10.80
6+112.2	2.40	6+119.0	2.40	LT 6.78	SKIP/DASH 1.67
TOTAL = 3264					

RELOCATE TEMPORARY CONCRETE BARRIER		
STA	STA	LENGTH
<b>115 ST STREET</b>		
2+345.0	2+423.0	LT 80.51
TOTAL = 81		

WET TEMPORARY PAVEMENT MARKING TAPE, TYPE III (LINE 600 MM)						
STA	OFFSET	OFFSET	LENGTH M	LINE TYPE	TOT LENGTH M	
<b>STAGE I-B</b>						
<b>MARSHFIELD AVENUE</b>						
4+136.0	5.70	RT 2.04	3.66	SOLID WHITE	3.66	
<b>STAGE II</b>						
<b>115 TH STREET</b>						
2+273.0	3.30	LT 6.35	3.05	SOLID WHITE	3.05	
2+288.0	3.80	LT 6.85	3.05	SOLID WHITE	3.05	
2+318.0	1.85	LT 4.90	3.05	SOLID WHITE	3.05	
2+346.0	6.95	LT 10.00	3.05	SOLID WHITE	3.05	
2+350.0	6.95	LT 3.90	3.05	SOLID WHITE	3.05	
2+415.0	3.90	LT 6.95	3.05	SOLID WHITE	3.05	
2+419.0	0.85	LT 3.90	3.05	SOLID WHITE	3.05	
2+443.0	4.30	LT 7.35	3.05	SOLID WHITE	3.05	
<b>MARSHFIELD AVENUE</b>						
4+145.5	8.73	LT 1.97	10.70	SOLID WHITE	10.70	
<b>STAGE II-B</b>						
<b>MARSHFIELD AVENUE</b>						
4+145.5	2.67	RT 5.72	3.05	SOLID WHITE	3.05	
<b>ASHLAND AVENUE</b>						
6+119.0	0.44	RT 5.66	6.10	SOLID WHITE	6.10	
<b>STAGE III</b>						
<b>115 TH STREET</b>						
2+325.2	3.60	RT 7.50	3.90	SOLID WHITE	3.90	
2+419.5	3.50	RT 10.00	6.50	SOLID WHITE	6.50	
TOTAL = 58						
<b>THERMOPLASTIC PAVEMENT MARKING - LETTERS AND SYMBOLS</b>						
STA	OFFSET	LETTER	TOT AREA SQ M			
<b>115TH STREET</b>						
2+278.8	0.75	R	0.33			
2+278.8	2.58	R	0.33			
2+278.8	3.88	R	0.33			
2+278.8	5.74	R	0.33			
TOTAL = 1						
<b>THERMOPLASTIC PAVEMENT MARKING - LINE 100 MM</b>						
STA	OFFSET	STA	OFFSET	LENGTH M	LINE TYPE	TOT LENGTH M
<b>115TH STREET</b>						
2+134.0	3.20	RT 2+322.0	3.90	188.00	SKIP/DASH	188.00
2+261.0	0.00	RT 2+324.1	0.00	63.10	DBL YELLOW	126.20
2+291.7	0.00	RT 2+324.1	0.00	32.40	DBL YELLOW	64.80
2+257.8	2.90	LT 2+322.0	4.50	64.20	SKIP/DASH	15.83
2+443.5	4.10	RT 2+649.0	3.05	205.50	SKIP/DASH	50.67
2+443.5	4.10	LT 2+649.0	3.05	205.50	SKIP/DASH	50.67
2+442.2	0.00	RT 2+511.7	0.00	69.50	DBL YELLOW	139.00
2+442.2	0.00	RT 2+649.0	0.00	206.80	DBL YELLOW	413.60
<b>MARSHFIELD AVENUE</b>						
4+115.0	1.90	RT 4+120.0	1.90	5.00	SKIP/DASH	1.23
4+115.0	1.90	LT 4+120.0	1.90	5.00	SKIP/DASH	1.23
4+144.0	1.70	LT 4+215.0	1.70	71.00	SKIP/DASH	17.51
4+142.0	1.90	RT 4+209.3	5.50	67.30	SOLID WHITE	67.30
<b>ASHLAND AVENUE</b>						
6+076.6	1.25	LT 6+117.5	1.95	40.90	SKIP/DASH	10.08
6+076.6	2.35	RT 6+117.5	1.65	40.90	SKIP/DASH	10.08
6+144.0	1.56	LT 6+152.7	1.82	8.66	SKIP/DASH	2.14
6+144.0	2.04	RT 6+152.7	1.78	8.66	SKIP/DASH	2.14
6+085.2	8.29	RT 6+118.9	7.09	33.70	SOLID WHITE	33.70
TOTAL = 1194						

THERMOPLASTIC PAVEMENT MARKING - LINE 150 MM						
STA	OFFSET	OFFSET	LENGTH M	LINE TYPE	TOT LENGTH M	
<b>115TH STREET</b>						
2+323.4	9.36	LT 7.30	16.66	SOLID WHITE	16.66	
2+325.2	10.35	LT 7.80	18.15	SOLID WHITE	18.15	
2+439.6	8.29	LT 10.45	18.74	SOLID WHITE	18.74	
2+441.4	7.60	LT 8.99	16.59	SOLID WHITE	16.59	
<b>MARSHFIELD AVENUE</b>						
4+119.9	6.82	LT 5.59	12.41	SOLID WHITE	12.41	
4+121.7	8.15	LT 6.69	14.84	SOLID WHITE	14.84	
4+142.9	12.15	LT 6.80	18.95	SOLID WHITE	18.95	
4+144.7	9.81	LT 5.76	15.57	SOLID WHITE	15.57	
<b>ASHLAND AVENUE</b>						
6+119.1	5.58	LT 8.59	14.17	SOLID WHITE	14.17	
6+120.9	5.99	LT 9.54	15.53	SOLID WHITE	15.53	
6+142.2	7.70	LT 8.42	16.12	SOLID WHITE	16.12	
6+144.0	6.57	LT 6.90	13.47	SOLID WHITE	13.47	
TOTAL = 191						

THERMOPLASTIC PAVEMENT MARKING - LINE 300 MM				
STA	STA	LENGTH M	LINE TYPE	TOT LENGTH M
<b>115TH STREET</b>				
2+291.7	2+323.3	5.80	DIAGONAL YELLOW	5.80
2+442.8	2+511.7	9.90	DIAGONAL YELLOW	9.90
<b>MARSHFIELD AVENUE</b>				
4+144.0	RT 4+209.3	29.90	DIAGONAL WHITE	29.90
<b>ASHLAND AVENUE</b>				
6+085.0	RT 6+119.0	15.80	DIAGONAL WHITE	15.80
TOTAL = 61				

THERMOPLASTIC PAVEMENT MARKING - LINE 400 MM						
STA	OFFSET	OFFSET	LENGTH M	LINE TYPE	TOT LENGTH M	
<b>115TH STREET</b>						
2+276.4	5.82	LT 2+281.5	3.80	6.25	SOLID WHITE 6.25	
2+276.4	3.80	LT 2+281.5	5.82	6.25	SOLID WHITE 6.25	
2+276.4	2.71	LT 2+281.5	0.69	6.25	SOLID WHITE 6.25	
2+276.4	0.69	LT 2+281.5	2.71	6.25	SOLID WHITE 6.25	
TOTAL = 25						

THERMOPLASTIC PAVEMENT MARKING - LINE 600 MM						
STA	OFFSET	OFFSET	LENGTH M	LINE TYPE	TOT LENGTH M	
<b>115TH STREET</b>						
2+267.2	0.00	LT 5.95	5.95	SOLID WHITE	5.95	
2+272.4	0.00	LT 6.10	6.10	SOLID WHITE	6.10	
2+285.1	0.00	LT 6.77	6.77	SOLID WHITE	6.77	
2+322.0	0.80	RT 7.40	6.60	SOLID WHITE	6.60	
2+443.5	0.80	LT 7.40	6.60	SOLID WHITE	6.60	
<b>MARSHFIELD AVENUE</b>						
4+146.0	8.73	LT 1.96	10.50	SOLID WHITE	10.50	
<b>ASHLAND AVENUE</b>						
6+117.5	5.56	LT 6.26	12.00	SOLID WHITE	12.00	
TOTAL = 55						

FILE: g:\2904\civil\exhibit\2904014.dgn DATE: 19-Nov-07 14:48



REVISIONS		ILLINOIS DEPARTMENT OF TRANSPORTATION
NAME	DATE	
		SCHEDULE OF QUANTITIES

DRAWN BY: PRH  
CHECKED BY: JMH  
DATE: JANUARY 16, 2009

WORK ZONE PAVEMENT MARKING REMOVAL								
STA	OFFSET	STA	OFFSET	LENGTH M	LINE TYPE	TOT LENGTH M	TOT AREA SQ M	
LETTERS & SYMBOLS								
STAGE II								
115TH STREET								
2+280.7	LT				R		0.33	
2+280.7	LT				R		0.33	
2+359.8	LT				LT ARROW		1.47	
2+367.2	LT				ONLY		2.13	
2+399.0	LT				ONLY		2.13	
2+407.0	LT				LT ARROW		1.47	
STAGE III								
115 TH STREET								
2+361.0	LT				LT ARROW		1.47	
2+368.0	LT				ONLY		2.13	
2+397.9	RT				ONLY		2.13	
2+404.9	RT				LT ARROW		1.47	
100 MM								
STAGE I								
115TH STREET								
2+134.0	0.00	2+261.0	0.30	RT	91.00 SOLID YELLOW	91.00	9.10	
2+134.0	0.00	2+261.0	3.30	RT	97.00 SOLID YELLOW	97.00	9.70	
2+250.5	2.90	2+261.0	2.90	LT	10.50 SOLID WHITE	10.50	1.05	
2+519.4	3.40	2+524.0	3.40	RT	4.75 DBL YELLOW	9.50	0.95	
2+519.4	0.40	2+637.0	6.10	LT	115.00 SOLID WHITE	115.00	11.50	
2+540.0	3.00	2+615.0	0.00		59.00 SOLID YELLOW	59.00	5.90	
2+540.0	3.00	2+625.0	3.20	RT	71.00 SOLID YELLOW	71.00	7.10	
MARSHFIELD AVENUE								
4+155.0	2.00	4+235.0	5.40	RT	80.70 SOLID YELLOW	80.70	8.07	
4+132.0	8.30	4+257.0	5.17	LT	116.00 SOLID WHITE	116.00	11.60	
4+132.0	8.80	4+142.0	5.70	RT	13.00 SOLID YELLOW	13.00	1.30	
ASHLAND AVENUE								
6+010.0	3.00	6+112.2	0.50	RT	102.25 SOLID YELLOW	102.25	10.22	
6+010.0	8.00	6+112.2	1.00	RT	95.00 SOLID WHITE	95.00	9.50	
6+132.0	8.00	6+145.0	6.50	LT	15.00 SOLID YELLOW	15.00	1.50	
6+131.0	12.80	6+152.7	0.00		31.00 SOLID WHITE	31.00	3.10	
STAGE II								
115 TH STREET								
2+169.0	6.00	2+261.0	3.24	RT	77.40 SOLID WHITE	77.40	7.74	
2+250.0	2.90	2+318.5	4.90	LT	60.20 SOLID YELLOW	60.20	6.02	
2+250.0	0.00	2+318.5	4.90	LT	56.20 SOLID YELLOW	56.20	5.62	
2+318.5	5.00	2+346.0	3.45	LT	27.54 DOTTED	6.89	0.69	
2+346.0	3.45	2+419.0	6.55	LT	74.00 DBL YELLOW	148.00	14.80	
2+419.0	6.55	2+443.0	4.48	LT	23.00 DOTTED	5.75	0.58	
2+346.0	0.00	2+419.0	0.00		73.00 SOLID WHITE	73.00	7.30	
2+443.0	4.50	2+545.0	3.13	LT	102.01 DBL YELLOW	204.02	20.40	
2+545.0	3.13	2+649.0	0.00		75.00 SOLID YELLOW	75.00	7.50	
2+545.0	3.13	2+649.0	0.00		75.00 SOLID YELLOW	75.00	7.50	
MARSHFIELD AVENUE								
4+145.5	2.00	4+235.0	5.40	RT	89.56 SOLID YELLOW	89.56	8.96	
4+145.5	1.78	4+155.0	1.78	LT	9.50 SKIP/DASH	2.34	0.23	
4+115.0	2.50	4+133.0	12.50	LT	29.00 SOLID WHITE	29.00	2.90	
4+115.0	5.53	4+132.0	6.80	RT	17.05 SOLID YELLOW	17.05	1.70	
4+145.5	2.60	4+257.0	5.20	LT	84.00 SOLID WHITE	84.00	8.40	
ASHLAND AVENUE								
6+010.0	3.00	6+112.2	0.50	RT	102.25 SOLID YELLOW	102.25	10.22	
6+010.0	8.00	6+133.0	8.50	RT	118.00 SOLID WHITE	118.00	11.80	
6+120.0	5.60	6+132.0	8.00	LT	14.00 SOLID YELLOW	14.00	1.40	
6+112.2	2.40	6+119.0	2.40	LT	6.78 SKIP/DASH	1.67	0.17	
STAGE III								
115 TH STREET								
2+134.0	0.00	2+235.0	0.00		79.00 SOLID YELLOW	79.00	7.90	
2+134.0	0.00	2+235.0	3.05	RT	84.00 SOLID YELLOW	84.00	8.40	
2+250.5	2.90	2+328.0	0.00		80.00 SOLID YELLOW	80.00	8.00	
2+248.5	3.00	2+328.0	0.00		83.00 SOLID YELLOW	83.00	8.30	
2+346.0	0.00	2+420.0	0.00		81.00 SOLID YELLOW	81.00	8.10	
2+346.0	0.00	2+420.0	0.00		81.00 SOLID YELLOW	81.00	8.10	
2+441.0	0.00	2+569.0	0.00		131.00 SOLID YELLOW	131.00	13.10	
2+441.0	0.00	2+569.0	0.00		131.00 SOLID YELLOW	131.00	13.10	
2+569.0	0.00	2+600.0	0.00		31.00 DBL YELLOW	62.00	6.20	
2+323.0	7.50	2+334.0	8.34	RT	11.03 SOLID WHITE	11.03	1.10	
2+318.0	7.95	2+335.0	9.35	LT	17.06 SOLID WHITE	17.06	1.71	
2+431.0	9.23	2+446.0	7.42	RT	15.11 SOLID WHITE	15.11	1.51	
2+431.0	8.86	2+443.0	7.51	LT	12.08 SOLID WHITE	12.08	1.21	
MARSHFIELD AVENUE								
4+115.0	0.75	4+123.0	2.58	LT	8.21 SOLID WHITE	8.21	0.82	
4+142.0	1.46	4+257.0	5.16	LT	99.00 SOLID WHITE	99.00	9.90	
4+145.5	1.79	4+155.0	1.79	RT	9.50 SKIP/DASH	2.34	0.23	
ASHLAND AVENUE								
6+010.0	8.04	6+123.0	2.95	RT	108.00 SOLID WHITE	108.00	10.80	
6+142.0	1.75	6+152.7	0.00		10.80 SOLID WHITE	10.80	1.08	
6+112.2	2.40	6+119.0	2.40	LT	6.78 SKIP/DASH	1.67	0.17	

WORK ZONE PAVEMENT MARKING REMOVAL (CONTINUED)												
STA	OFFSET	STA	OFFSET	LENGTH M	LINE TYPE	TOT LENGTH M	TOT AREA SQ M					
150 MM												
115 TH STREET												
STAGE II												
115TH STREET												
2+346.0	6.55	LT	2+370.0	6.55	LT	24.00	SOLID WHITE	24.00	3.60			
2+370.0	6.55	LT	2+395.0	6.55	LT	25.00	SKIP/DASH	6.25	0.94			
2+370.0	3.50	LT	2+395.0	3.50	LT	25.00	SKIP/DASH	6.25	0.94			
2+395.0	3.50	LT	2+419.5	3.50	LT	24.50	SOLID WHITE	24.50	3.68			
STAGE III												
115 TH STREET												
2+346.0	7.10	LT	2+370.0	7.10	LT	24.00	SOLID WHITE	24.00	3.60			
2+370.0	7.10	LT	2+395.0	7.10	LT	25.00	SKIP/DASH	6.25	0.94			
2+370.0	6.55	RT	2+395.0	6.55	RT	25.00	SKIP/DASH	6.25	0.94			
2+395.0	6.55	RT	2+419.5	6.55	RT	24.50	SOLID WHITE	24.50	3.68			
300 MM												
STAGE II & STAGE III												
115TH STREET												
2+277.5	3.75	LT	2+283.9	6.38	LT	6.54	SOLID WHITE	6.54	1.96			
2+277.5	6.16	LT	2+283.9	3.97	LT	6.54	SOLID WHITE	6.54	1.96			
600 MM												
STAGE I-B												
MARSHFIELD AVENUE												
4+136.0	5.70	RT		2.04	RT	3.66	SOLID WHITE	3.66	2.20			
STAGE II												
115 TH STREET												
2+273.0	3.30	LT		6.35	LT	3.05	SOLID WHITE	3.05	1.83			
2+288.0	3.80	LT		6.85	LT	3.05	SOLID WHITE	3.05	1.83			
2+318.0	1.85	LT		4.90	LT	3.05	SOLID WHITE	3.05	1.83			
2+346.0	6.95	LT		10.00	LT	3.05	SOLID WHITE	3.05	1.83			
2+350.0	6.95	LT		3.90	LT	3.05	SOLID WHITE	3.05	1.83			
2+415.0	3.90	LT		6.95	LT	3.05	SOLID WHITE	3.05	1.83			
2+419.0	0.85	LT		3.90	LT	3.05	SOLID WHITE	3.05	1.83			
2+443.0	4.30	LT		7.35	LT	3.05	SOLID WHITE	3.05	1.83			
MARSHFIELD AVENUE												
4+145.5	8.73	LT		1.97	RT	10.70	SOLID WHITE	10.70	6.42			
STAGE II-B												
MARSHFIELD AVENUE												
4+145.5	2.67	RT		5.72	RT	3.05	SOLID WHITE	3.05	1.83			
ASHLAND AVENUE												
6+119.0	0.44	RT		5.66	LT	6.10	SOLID WHITE	6.10	3.66			
STAGE III												
115 TH STREET												
2+325.2	3.60	RT		7.50	RT	3.90	SOLID WHITE	3.90	2.34			
2+419.5	3.50	RT		10.00	RT	6.50	SOLID WHITE	6.50	3.90			
TOTAL										=	397	
POLYUREA PAVEMENT MARKING TYPE I - LETTERS AND SYMBOLS												
TOTAL LENGTH SQ M												
STA	OFFSET											
115TH STREET												
2+359.8	0.00				LT ARROW		1.47					
2+366.6	0.00				ONLY		2.13					
2+395.4	0.00				ONLY		2.13					
2+402.6	0.00				LT ARROW		1.47					
TOTAL										=	7	
POLYUREA PAVEMENT MARKING TYPE B - LINE 100 MM												
STA	OFFSET	STA	OFFSET	LENGTH M	LINE TYPE	TOT LENGTH M	TOT AREA SQ M					
115TH STREET												
2+349.0	5.02	LT	2+416.5	4.99	LT	67.50	SKIP/DASH	16.64				
2+349.0	4.93	RT	2+416.5	4.93	RT	67.50	SKIP/DASH	16.64				
2+351.0	1.39	RT	2+412.0	1.39	LT	61.50	DBL YELLOW	123.00				
2+343.7	8.25	LT	2+422.1	8.25	LT	78.40	SOLID WHITE	78.40				
2+343.7	8.25	RT	2+422.1	8.25	RT	78.40	SOLID WHITE	78.40				
TOTAL										=	313	

POLYUREA PAVEMENT MARKING TYPE B - LINE 100 MM											
STA	OFFSET	STA	OFFSET	LENGTH M	LINE TYPE	TOT LENGTH M	TOT AREA SQ M				
115TH STREET											
2+349.0	1.66	LT	2+370.5	1.66	LT	21.50	SOLID WHITE	21.50			
2+391.5	1.67	RT	2+416.5	1.67	RT	25.00	SOLID WHITE	25.00			
2+370.5	1.66	LT	2+390.5	1.66	LT	20.00	DOTTED	5.00			
2+371.5	1.67	RT	2+391.5	1.67	RT	20.00	DOTTED	5.00			
TOTAL										=	57

POLYUREA PAVEMENT MARKING TYPE B - LINE 300 MM										
STA	OFFSET	STA	OFFSET	LENGTH M	LINE TYPE	TOT LENGTH M	TOT AREA SQ M			
115TH STREET										
2+343.7	8.25	LT	2+422.1	8.25	LT	32.50	SOLID WHITE	32.50		
2+343.7	8.25									

F.A.I.	SECTION	COUNTY	TOTAL SHEETS	SHEET NO.
57	1919.2B	COOK	119	16
FED. ROAD DIST. NO.		ILLINOIS	FED. AID PROJECT	

PAVEMENT MARKING REMOVAL

STA	OFFSET	STA	OFFSET	LENGTH M	LINE TYPE	TOT LENGTH M	TOT AREA SQ M
<b>115TH STREET</b>							
2+134.0	RT	2+322.8	RT	188.80	LANE LINE	46.55	4.66
2+348.5	RT	2+415.8	RT	67.30	LANE LINE	16.59	1.66
2+443.2	RT	2+650.0	RT	206.80	LANE LINE	50.99	5.10
2+519.0	LT	2+650.0	LT	131.00	LANE LINE	32.30	3.23
2+370.0	RT	2+417.0	RT	47.00	SOLID WHITE	47.00	7.05
2+261.0		2+325.0	LT	64.00	DBLE YELLOW	128.00	12.80
2+343.0		2+425.0		82.00	DBLE YELLOW	164.00	16.40
2+519.0		2+650.0		131.00	DBLE YELLOW	262.00	26.20
2+257.5			LT	6.00	STOP BAR	6.00	3.60
2+272.7			LT	6.10	STOP BAR	6.10	3.66
2+285.2			LT	6.60	STOP BAR	6.60	3.96
2+322.0			RT	7.30	STOP BAR	7.30	4.38
2+420.0	RT		RT	8.50	STOP BAR	8.50	5.10
2+323.4	LT		RT	8.00	CROSS WALK	8.00	1.20
2+325.3	LT		RT	8.00	CROSS WALK	8.00	1.20
2+439.6	LT		RT	9.00	CROSS WALK	9.00	1.35
2+441.4	LT		RT	8.00	CROSS WALK	8.00	1.20
2+279.2	LT				R		0.33
2+279.2	LT				R		0.33
2+279.2	LT				R		0.33
2+279.2	LT			6.00	X	12.00	4.80
2+279.2	LT			6.00	X	12.00	4.80
2+360.0					ONLY		2.13
2+366.0					LT/ARROW		1.47
2+396.0					ONLY		2.13
2+402.0					LT/ARROW		1.47
<b>MARSHFIELD AVENUE</b>							
4+145.8	LT	4+220.0	LT	74.20	LANE LINE	18.30	1.83
4+145.8	RT	4+220.0	RT	74.20	LANE LINE	18.30	1.83
4+145.6	LT		RT	12.40	STOP BAR	12.40	7.44
4+119.9	LT		RT	13.60	CROSS WALK	13.60	2.04
4+121.8	LT		RT	15.00	CROSS WALK	15.00	2.25
4+142.4	LT		RT	15.00	CROSS WALK	15.00	2.25
4+144.2	LT		RT	14.00	CROSS WALK	14.00	2.10
<b>ASHLAND AVENUE</b>							
6+077.5	LT	6+120.0	LT	42.50	LANE LINE	10.48	1.05
6+077.5	RT	6+120.0	RT	42.50	LANE LINE	10.48	1.05
6+117.5	LT		RT	14.00	STOP BAR	14.00	8.40
6+119.2	LT		RT	14.00	CROSS WALK	14.00	2.10
6+120.9	LT		RT	15.00	CROSS WALK	15.00	2.25
6+142.2	LT		RT	16.00	CROSS WALK	16.00	2.40
6+143.6	LT		RT	14.00	CROSS WALK	14.00	2.10
TOTAL						=	160

STORM SEWERS TO BE CLEANED

STA	OFFSET	STA	OFFSET	SIZE (MM)	LENGTH		
<b>115 STREET</b>							
2+174.6	0.5	LT	2+291.4	0.4	RT	2300	115.8
2+192.6	6.0	LT	2+192.6	0.4	LT	300	3.8
2+192.8	6.4	RT	2+192.8	0.4	LT	300	5.0
2+289.3	6.7	RT	2+291.4	0.4	RT	200	5.4
2+291.8	6.0	LT	2+291.4	0.4	RT	300	5.2
2+293.8	6.5	LT	2+291.8	6.0	LT	300	0.9
2+323.8	11.9	LT	2+337.6	9.0	LT	250	12.9
2+335.7	9.6	RT	2+336.5	0.5	RT	700	7.3
2+336.5	0.5	RT	2+337.6	9.0	LT	700	7.8
2+335.7	9.6	RT	2+345.0	10.1	RT	300	8.1
2+337.6	9.0	LT	2+344.7	10.1	LT	300	6.0
2+291.4	0.4	RT	2+426.6	1.3	RT	2300	134.0
2+421.5	1.0	RT	2+421.9	9.9	RT	250	7.1
2+421.5	10.1	LT	2+428.0	9.5	LT	200	5.7
2+426.6	1.3	RT	2+427.0	21.0	RT	400	18.5
2+429.0	20.0	LT	2+548.5	0.3	LT	2300	120.7
2+479.0	0.6	RT	2+426.6	1.3	RT	400	20.2
2+479.1	7.8	RT	2+479.9	5.6	LT	250	4.5
2+479.9	5.6	LT	2+479.1	6.3	RT	250	0.3
2+479.1	6.3	RT	2+480.8	6.9	LT	250	0.7
2+525.0	6.5	LT	2+484.0	0.5	RT	250	5.8
2+525.0	0.0		2+525.0	0.0		250	4.7
2+525.0	0.0		2+525.0	7.5	RT	250	5.7
<b>MARSHFIELD AVENUE</b>							
4+058.0	0.0		4+058.0	5.0	LT	300	4.1
4+058.0	0.0		4+058.0	5.5	RT	250	5.0
4+070.0	0.0		4+122.0	1.5	LT	700	50.8
4+141.5	0.5	RT	4+190.0	0.0		700	47.3
4+167.5	0.0		4+170.0	6.5	LT	250	6.1
4+178.5	0.0		4+180.0	5.5	RT	250	4.8
<b>ASHLAND AVENUE</b>							
6+105.5	5.5	LT	6+105.5	1.5	LT	250	3.2
6+107.0	1.5	LT	6+107.0	6.5	RT	300	7.2
6+108.0	7.5	RT	6+107.0	6.5	RT	300	0.2
6+152.1	0.2	LT	6+208.0	0.5	LT	400	54.7
6+164.0	4.5	RT	6+164.5			300	3.7
6+165.0	0.0		6+165.0	6.0	LT	300	5.2
TOTAL =						698	

FILE: g:\2904\civil\exhibit\2904015a.dgn  
DATE: 19-Nov-07 14:48

REVISIONS	
NAME	DATE

ILLINOIS DEPARTMENT OF TRANSPORTATION  
SCHEDULE OF QUANTITIES  
DRAWN BY: PRH  
CHECKED BY: JMH  
DATE: JANUARY 16, 2009

**COLLINS ENGINEERS**  
123 North Wacker Drive  
Suite 300  
Chicago, IL 60606  
(312) 704-9300  
www.collinsengr.com  
ILLINOIS PROFESSIONAL DESIGN FIRM LICENSE NO. 184-000993



F.A.I.	SECTION	COUNTY	TOTAL SHEETS	SHEET NO.
57	1919.2B	COOK	119	17
FED. ROAD DIST. NO.		ILLINOIS FED. AID PROJECT	CONTRACT 60371	



BENCH MARK:

NO. 384 EL. 187.482 (615.098 FT.)  
120th STREET AND JUSTINE STREET  
2.682 m (8.8 FT.) WEST OF EAST LINE OF  
JUSTINE STREET AND 6.645m (21.8 FT.)  
SOUTH OF SOUTH LINE OF 120th STREET.

TP #124  
CUT X IN SIDEWALK  
N: 20978.446  
E: 19623.378

FIRE HYDRANT  
N.W. CORNER OF  
115th AND DAVOL  
6.02 m

CATCH BASIN  
NORTH SIDE OF  
115th STREET  
4.62 m

LIGHT POLE  
N.W. CORNER OF  
115th AND DAVOL  
2.32 m

CONSTRUCTION BEGINS  
115TH STREET  
STA. 2+261.000

LIMIT OF CONSTRUCTION  
MARSHFIELD AVENUE  
STA. 4+155.000

SOUTH FACE OF LIGHTPOLE  
NORTH SIDE OF  
115th STREET

STA. EQUATION  
2+337.127 115th ST.  
4+131.973 MARSHFIELD AVE.  
N: 20987.255  
E: 19803.167

LIMIT OF CONSTRUCTION  
MARSHFIELD AVENUE  
STA. 4+115.000

CATCH BASIN  
SOUTH SIDE OF  
115th STREET  
9.73 m

UTILITY POLE  
SOUTH SIDE OF  
115th STREET  
11.12 m

TP #126  
CUT X ON CURB  
N: 20960.863  
E: 19603.715

CUT X ON CURB  
NW CORNER OF  
115th AND  
MARSHFIELD AVE.  
3.64 m

CUT X ON CONC.  
BASE FOR LIGHTPOLE  
NW CORNER 115th ST.  
AND MARSHFIELD AVE.  
6.45 m

CUT X ON CURB  
NE CORNER OF  
115th AND  
MARSHFIELD AVE.

115th STREET

TP #123  
N: 20996.975  
E: 19792.680  
ELEV: 187.612

FAI 57

FAI 57

TP #113  
N: 21018.359  
E: 20041.191  
ELEV: 186.907

33.95 m  
CORNER OF BUILDING  
115th STREET

42.99 m  
CORNER OF BUILDING  
115th STREET

115th STREET

40.99 m  
SIGN

43.00 m  
TSCX 113

STA. 2+382.914

LIMIT OF CONSTRUCTION  
ASHLAND AVENUE  
STA. 6+152.660

LIMIT OF RESURFACING  
115TH STREET  
STA. 2+519.400

STA. 2+440.352  
N: 20997.446  
E: 19905.888

STA. EQUATION  
2+429.167 115th ST.  
6+132.217 ASHLAND AVE.  
N: 20996.342  
E: 19894.758

LIMIT OF CONSTRUCTION  
ASHLAND AVENUE  
STA. 6+112.218

CUT X ON SOUTH CURB  
OF 115th STREET 7.90 m

WEST FACE OF  
LIGHTPOLE  
SW CORNER 115th.  
AND LAFLIN AVE.  
4.39 m

S. LAFLIN AVE.

NE CORNER OF  
FENCE ON SW CORNER  
OF LAFLIN AVE. AND  
115th STREET

TP #111  
N: 21005.082  
E: 20079.980  
ELEV: 187.027

REVISIONS	
NAME	DATE

ILLINOIS DEPARTMENT OF TRANSPORTATION

ALIGNMENT, TIES AND  
BENCHMARKS

115th STREET OVER I-57

SCALE: 1:750

DATE: JANUARY 16, 2009

DRAWN BY: PRH

CHECKED BY: JMH

5 m 0 20 m  
GRAPHIC SCALE IN METERS

**COLLINS ENGINEERS**  
123 North Wacker Drive  
Suite 300  
Chicago, IL 60606  
(312) 704-9300  
www.collinsengr.com  
ILLINOIS PROFESSIONAL DESIGN FIRM LICENSE NO. 184-000993

FILE: g:\2904\civil\exhib1\2904016.dgn  
DATE: 21-AUG-08 14:48

F.A.I.	SECTION	COUNTY	TOTAL SHEETS	SHEET NO.
57	1919.2B	COOK	119	18
FED. ROAD DIST. NO.		ILLINOIS FED. AID PROJECT		

CONTRACT 60371



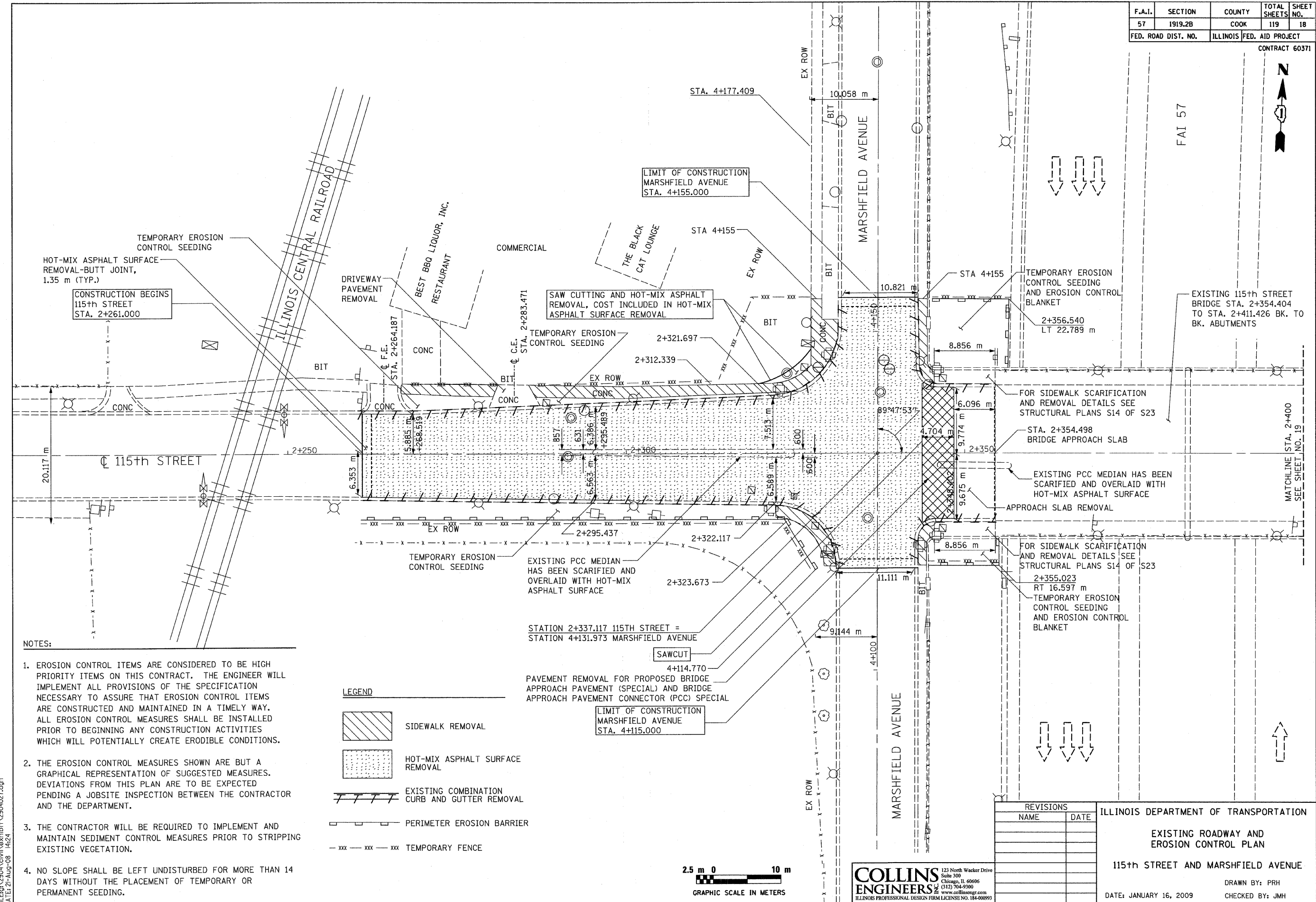

FAI 57



**NOTES:**

1. EROSION CONTROL ITEMS ARE CONSIDERED TO BE HIGH PRIORITY ITEMS ON THIS CONTRACT. THE ENGINEER WILL IMPLEMENT ALL PROVISIONS OF THE SPECIFICATION NECESSARY TO ASSURE THAT EROSION CONTROL ITEMS ARE CONSTRUCTED AND MAINTAINED IN A TIMELY WAY. ALL EROSION CONTROL MEASURES SHALL BE INSTALLED PRIOR TO BEGINNING ANY CONSTRUCTION ACTIVITIES WHICH WILL POTENTIALLY CREATE ERODIBLE CONDITIONS.
2. THE EROSION CONTROL MEASURES SHOWN ARE BUT A GRAPHICAL REPRESENTATION OF SUGGESTED MEASURES. DEVIATIONS FROM THIS PLAN ARE TO BE EXPECTED PENDING A JOBSITE INSPECTION BETWEEN THE CONTRACTOR AND THE DEPARTMENT.
3. THE CONTRACTOR WILL BE REQUIRED TO IMPLEMENT AND MAINTAIN SEDIMENT CONTROL MEASURES PRIOR TO STRIPPING EXISTING VEGETATION.
4. NO SLOPE SHALL BE LEFT UNDISTURBED FOR MORE THAN 14 DAYS WITHOUT THE PLACEMENT OF TEMPORARY OR PERMANENT SEEDING.

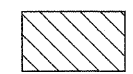
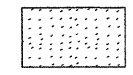
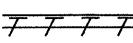
**LEGEND**

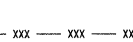
-  SIDEWALK REMOVAL
-  HOT-MIX ASPHALT SURFACE REMOVAL
-  EXISTING COMBINATION CURB AND GUTTER REMOVAL
-  PERIMETER EROSION BARRIER
-  TEMPORARY FENCE



**COLLINS ENGINEERS**  
 123 North Wacker Drive  
 Suite 300  
 Chicago, IL 60606  
 (312) 704-9300  
 www.collinsengr.com  
 ILLINOIS PROFESSIONAL DESIGN FIRM LICENSE NO. 184-000993

REVISIONS	
NAME	DATE

ILLINOIS DEPARTMENT OF TRANSPORTATION  
 EXISTING ROADWAY AND EROSION CONTROL PLAN  
 115th STREET AND MARSHFIELD AVENUE  
 DRAWN BY: PRH  
 CHECKED BY: JMH  
 DATE: JANUARY 16, 2009

FILE: g:\2904\civil\exhib\115\2904027.dgn  
 DATE: 21-AUG-08 14:24

F.A.I.	SECTION	COUNTY	TOTAL SHEETS	SHEET NO.
57	1919.2B	COOK	119	19
FED. ROAD DIST. NO.		ILLINOIS FED. AID PROJECT		
CONTRACT 60371				

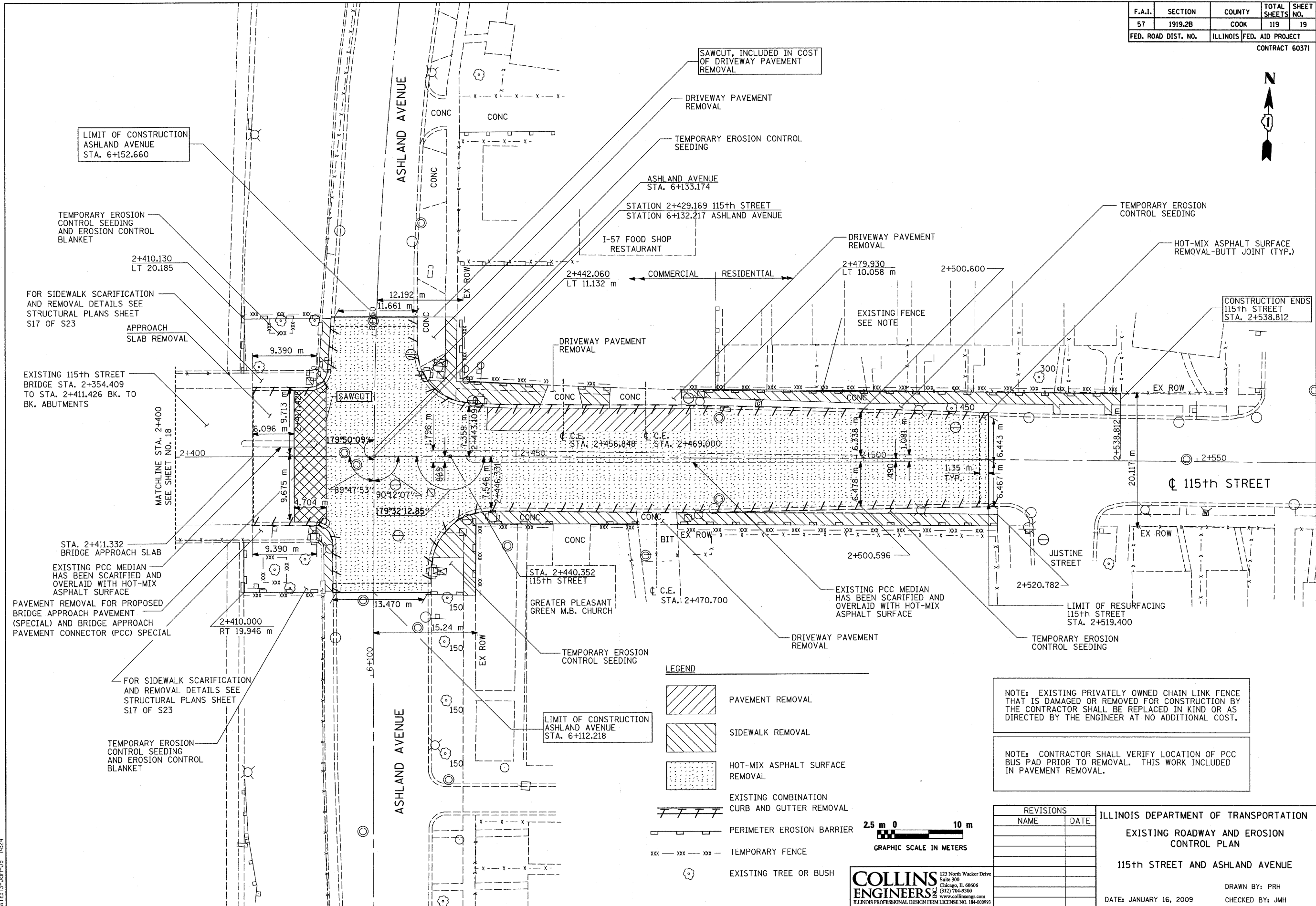

LIMIT OF CONSTRUCTION  
ASHLAND AVENUE  
STA. 6+152.660

TEMPORARY EROSION  
CONTROL SEEDING  
AND EROSION CONTROL  
BLANKET

FOR SIDEWALK SCARIFICATION  
AND REMOVAL DETAILS SEE  
STRUCTURAL PLANS SHEET  
S17 OF S23

EXISTING 115th STREET  
BRIDGE STA. 2+354.409  
TO STA. 2+411.426 BK. TO  
BK. ABUTMENTS

EXISTING PCC MEDIAN  
HAS BEEN SCARIFIED AND  
OVERLAID WITH HOT-MIX  
ASPHALT SURFACE

PAVEMENT REMOVAL FOR PROPOSED  
BRIDGE APPROACH PAVEMENT  
(SPECIAL) AND BRIDGE APPROACH  
PAVEMENT CONNECTOR (PCC) SPECIAL

FOR SIDEWALK SCARIFICATION  
AND REMOVAL DETAILS SEE  
STRUCTURAL PLANS SHEET  
S17 OF S23

TEMPORARY EROSION  
CONTROL SEEDING  
AND EROSION CONTROL  
BLANKET

SAWCUT, INCLUDED IN COST  
OF DRIVEWAY PAVEMENT  
REMOVAL

DRIVEWAY PAVEMENT  
REMOVAL

TEMPORARY EROSION CONTROL  
SEEDING

ASHLAND AVENUE  
STA. 6+133.174  
STATION 2+429.169 115th STREET  
STATION 6+132.217 ASHLAND AVENUE

I-57 FOOD SHOP  
RESTAURANT

DRIVEWAY PAVEMENT  
REMOVAL

TEMPORARY EROSION  
CONTROL SEEDING

HOT-MIX ASPHALT SURFACE  
REMOVAL-BUTT JOINT (TYP.)

CONSTRUCTION ENDS  
115th STREET  
STA. 2+538.812

DRIVEWAY PAVEMENT  
REMOVAL

EXISTING FENCE  
SEE NOTE

SAWCUT

C.C.E. STA. 2+456.848  
C.C.E. STA. 2+469.000

STA. 2+440.352  
115th STREET





GREATER PLEASANT  
GREEN M.B. CHURCH

C.C.E. STA. 2+470.700

EXISTING PCC MEDIAN  
HAS BEEN SCARIFIED AND  
OVERLAID WITH HOT-MIX  
ASPHALT SURFACE

LIMIT OF RESURFACING  
115th STREET  
STA. 2+519.400

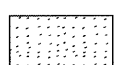
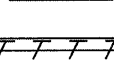
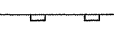
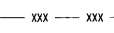
LEGEND

-  PAVEMENT REMOVAL
-  SIDEWALK REMOVAL
-  HOT-MIX ASPHALT SURFACE  
REMOVAL
-  EXISTING COMBINATION  
CURB AND GUTTER REMOVAL
-  PERIMETER EROSION BARRIER
-  TEMPORARY FENCE
-  EXISTING TREE OR BUSH

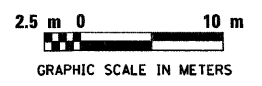

NOTE: EXISTING PRIVATELY OWNED CHAIN LINK FENCE  
THAT IS DAMAGED OR REMOVED FOR CONSTRUCTION BY  
THE CONTRACTOR SHALL BE REPLACED IN KIND OR AS  
DIRECTED BY THE ENGINEER AT NO ADDITIONAL COST.

NOTE: CONTRACTOR SHALL VERIFY LOCATION OF PCC  
BUS PAD PRIOR TO REMOVAL. THIS WORK INCLUDED  
IN PAVEMENT REMOVAL.

REVISIONS	
NAME	DATE

ILLINOIS DEPARTMENT OF TRANSPORTATION  
EXISTING ROADWAY AND EROSION  
CONTROL PLAN  
115th STREET AND ASHLAND AVENUE  
DRAWN BY: PRH  
CHECKED BY: JMH  
DATE: JANUARY 16, 2009

**COLLINS ENGINEERS**  
123 North Wacker Drive  
Suite 300  
Chicago, IL 60606  
(312) 704-9200  
www.collinsengr.com  
ILLINOIS PROFESSIONAL DESIGN FIRM LICENSE NO. 184-000993

FILE: g:\2904\civil\exhib\290402b.dgn  
DATE: 15-Jan-09 14:24

F.A.I.	SECTION	COUNTY	TOTAL SHEETS	SHEET NO.
57	1919.2B	COOK	119	20
FED. ROAD DIST. NO.		ILLINOIS FED. AID PROJECT	CONTRACT 60371	

FAI 57

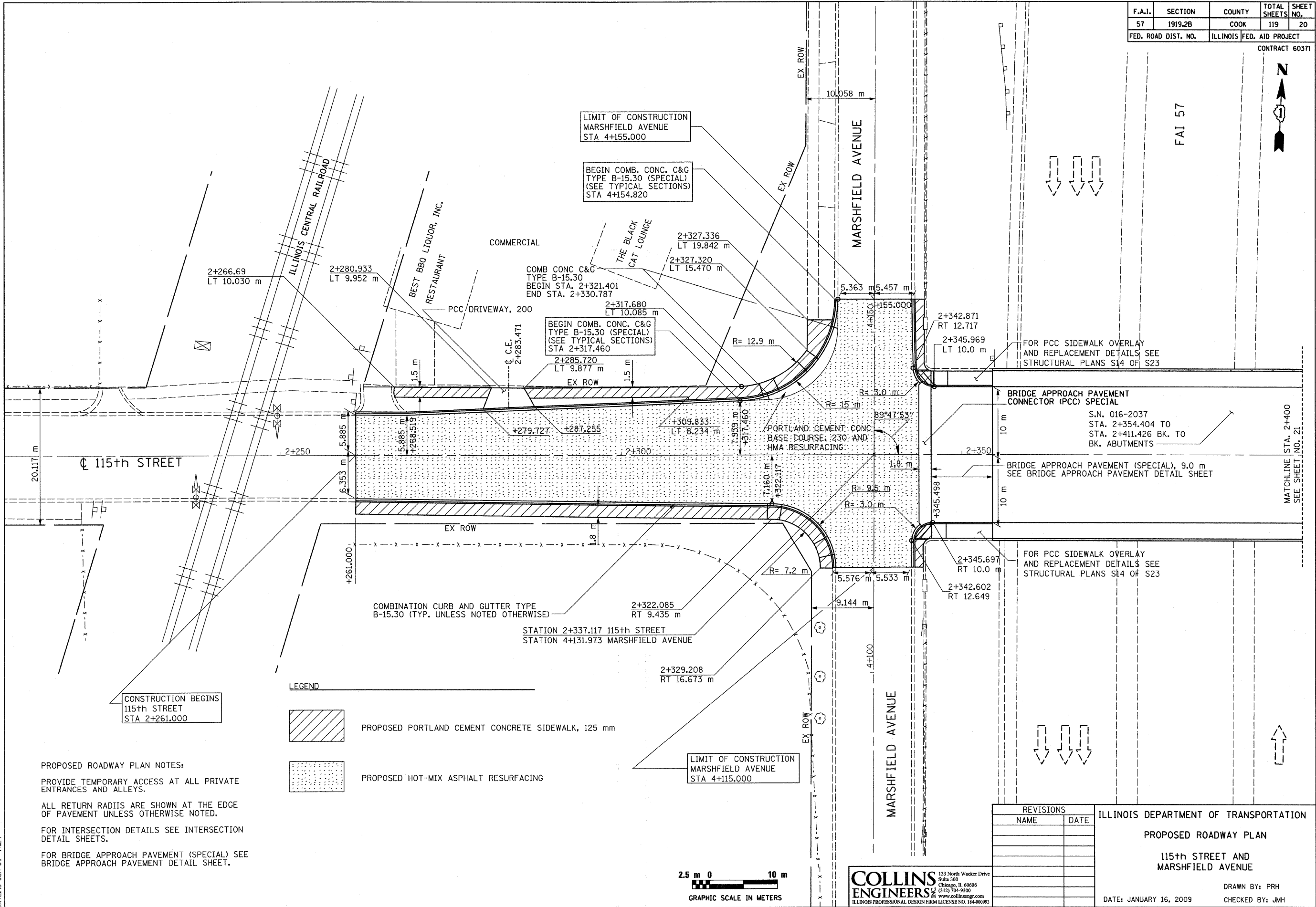
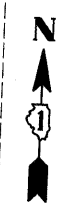

PROPOSED ROADWAY PLAN NOTES:  
 PROVIDE TEMPORARY ACCESS AT ALL PRIVATE ENTRANCES AND ALLEYS.  
 ALL RETURN RADII ARE SHOWN AT THE EDGE OF PAVEMENT UNLESS OTHERWISE NOTED.  
 FOR INTERSECTION DETAILS SEE INTERSECTION DETAIL SHEETS.  
 FOR BRIDGE APPROACH PAVEMENT (SPECIAL) SEE BRIDGE APPROACH PAVEMENT DETAIL SHEET.

LEGEND

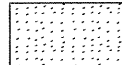
	PROPOSED PORTLAND CEMENT CONCRETE SIDEWALK, 125 mm
	PROPOSED HOT-MIX ASPHALT RESURFACING



**COLLINS ENGINEERS**  
 123 North Wacker Drive  
 Suite 300  
 Chicago, IL 60606  
 (312) 704-9300  
 www.collinsengr.com  
 ILLINOIS PROFESSIONAL DESIGN FIRM LICENSE NO. 184-000993

REVISIONS	
NAME	DATE

ILLINOIS DEPARTMENT OF TRANSPORTATION  
 PROPOSED ROADWAY PLAN  
 115th STREET AND  
 MARSHFIELD AVENUE  
 DATE: JANUARY 16, 2009  
 DRAWN BY: PRH  
 CHECKED BY: JMH

FILE: g:\2304\CIVIL\exhib1\2304023.dgn  
 DATE: 15-Jan-09 14:24

F.A.I.	SECTION	COUNTY	TOTAL SHEETS	SHEET NO.
57	1919.2B	COOK	119	21
FED. ROAD DIST. NO.		ILLINOIS FED. AID PROJECT		
CONTRACT 60371				

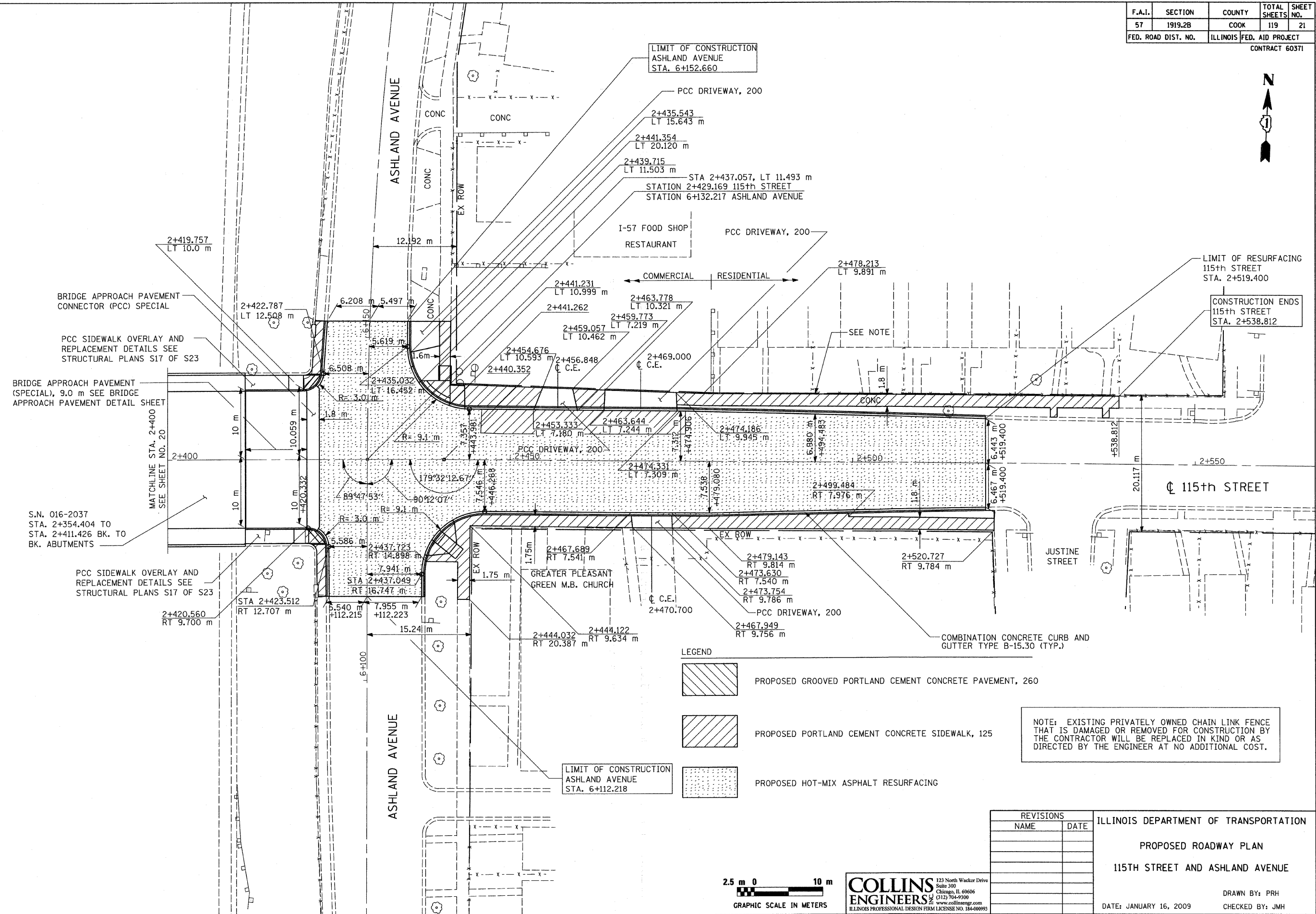

BRIDGE APPROACH PAVEMENT CONNECTOR (PCC) SPECIAL

PCC SIDEWALK OVERLAY AND REPLACEMENT DETAILS SEE STRUCTURAL PLANS S17 OF S23

BRIDGE APPROACH PAVEMENT (SPECIAL), 9.0 m SEE BRIDGE APPROACH PAVEMENT DETAIL SHEET

MATCHLINE STA. 2+400 SEE SHEET NO. 20

S.N. 016-2037 STA. 2+354.404 TO STA. 2+411.426 BK. TO BK. ABUTMENTS

PCC SIDEWALK OVERLAY AND REPLACEMENT DETAILS SEE STRUCTURAL PLANS S17 OF S23

- LEGEND**
- PROPOSED GROOVED PORTLAND CEMENT CONCRETE PAVEMENT, 260
  - PROPOSED PORTLAND CEMENT CONCRETE SIDEWALK, 125
  - PROPOSED HOT-MIX ASPHALT RESURFACING

NOTE: EXISTING PRIVATELY OWNED CHAIN LINK FENCE THAT IS DAMAGED OR REMOVED FOR CONSTRUCTION BY THE CONTRACTOR WILL BE REPLACED IN KIND OR AS DIRECTED BY THE ENGINEER AT NO ADDITIONAL COST.



**COLLINS ENGINEERS**  
 123 North Wacker Drive  
 Suite 300  
 Chicago, IL 60606  
 (312) 704-9300  
 www.collinsengr.com  
 ILLINOIS PROFESSIONAL DESIGN FIRM LICENSE NO. 184-000993

REVISIONS	
NAME	DATE

ILLINOIS DEPARTMENT OF TRANSPORTATION

PROPOSED ROADWAY PLAN

115TH STREET AND ASHLAND AVENUE

DATE: JANUARY 16, 2009

DRAWN BY: PRH  
 CHECKED BY: JMH

FILE: g:\2304\civil\exhibit\2304030.dgn  
 DATE: 21-Aug-08 14:24

F.A.I.	SECTION	COUNTY	TOTAL SHEETS	SHEET NO.
57	1919.2B	COOK	119	22
FED. ROAD DIST. NO.		ILLINOIS FED. AID PROJECT		CONTRACT 60371

BY	DATE
FINAL SURVEY PLOTTED	
NOTE BOOK TEMPLATE	
AREAS CHECKED	
NO.	

BY	DATE
ORIGINAL SURVEY PLOTTED	
NOTE BOOK TEMPLATE	
AREAS CHECKED	
NO.	

FILE: g:\2904\civil\exhib\1-290403.dgn  
DATE: 26-Aug-08 14:24

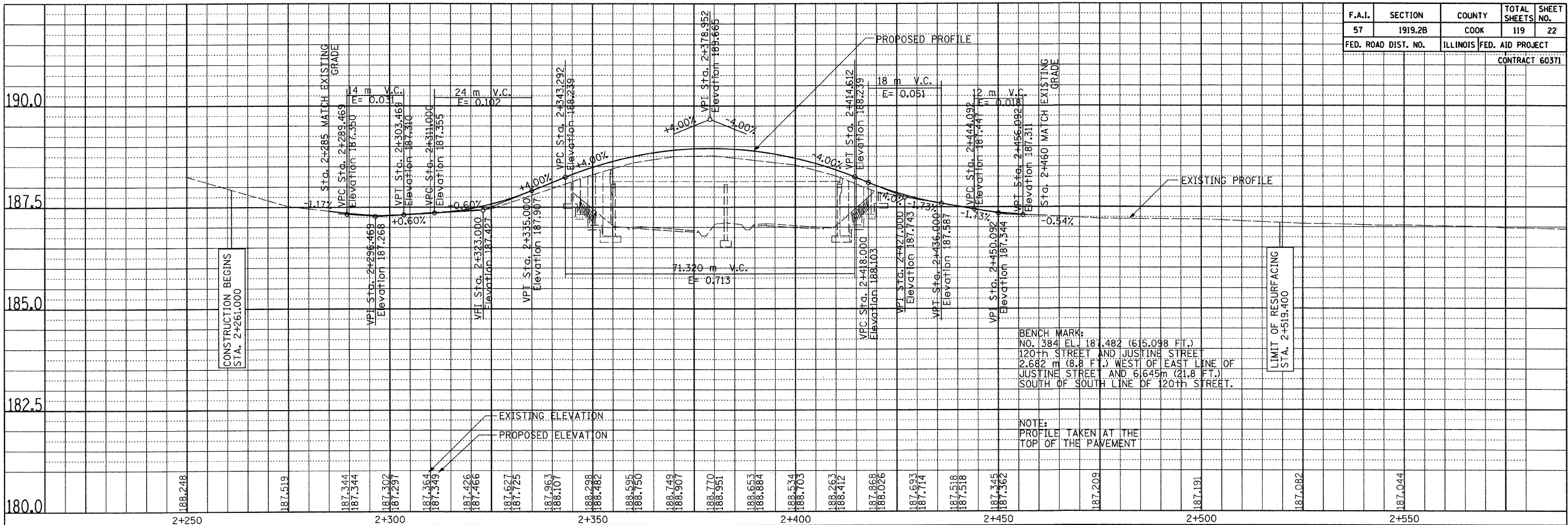

HORIZONTAL SCALE - 1:500  
VERTICAL SCALE - 1:50

REVISIONS		ILLINOIS DEPARTMENT OF TRANSPORTATION	
NAME	DATE		
		EXISTING AND PROPOSED PROFILE	
		115th OVER I-57	
		DRAWN BY ML	
		CHECKED BY: JMH	
		DATE: MARCH 2001	

**COLLINS ENGINEERS**  
123 North Wacker Drive  
Suite 300  
Chicago, IL 60606  
(312) 704-9300  
www.collinseng.com  
ILLINOIS PROFESSIONAL DESIGN FIRM LICENSE NO. 184-000993

F.A.I.	SECTION	COUNTY	TOTAL SHEETS	SHEET NO.
57	1919.2B	COOK	119	23
FED. ROAD DIST. NO.		ILLINOIS FED. AID PROJECT		
CONTRACT 60371				

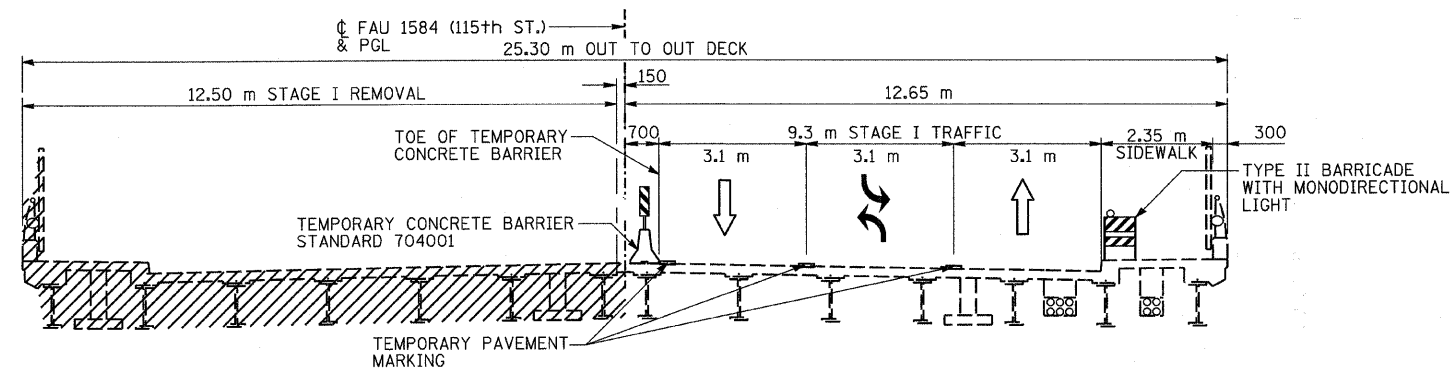

STAGE I TYPICAL BRIDGE SECTION  
(LOOKING EAST)

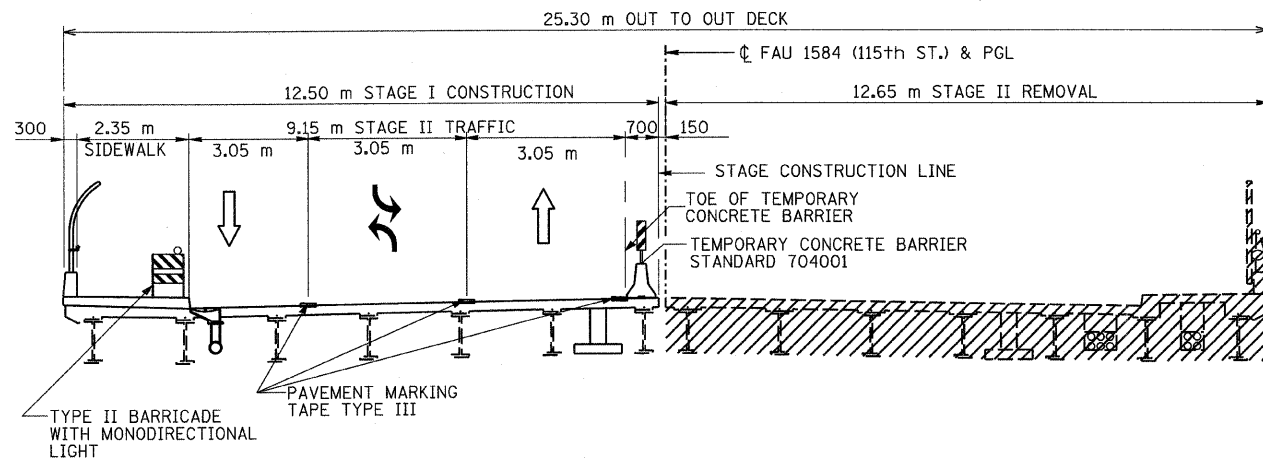

STAGE II TYPICAL BRIDGE SECTION  
(LOOKING EAST)

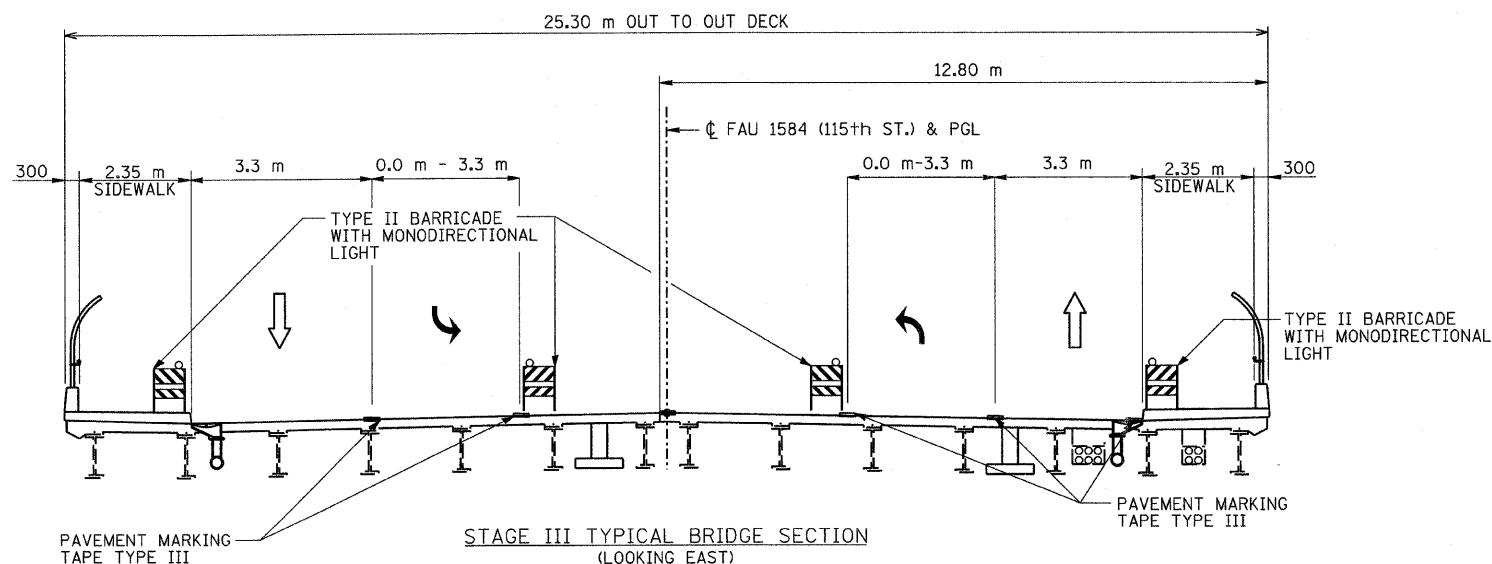

STAGE III TYPICAL BRIDGE SECTION  
(LOOKING EAST)

NOTE:  
REMOVE EXISTING PAVEMENT MARKINGS IN STAGES WHICH CONFLICT WITH TEMPORARY PAVEMENT MARKING OR PAVEMENT MARKING TAPE TYPE III FOR ALL CONSTRUCTION STAGES.

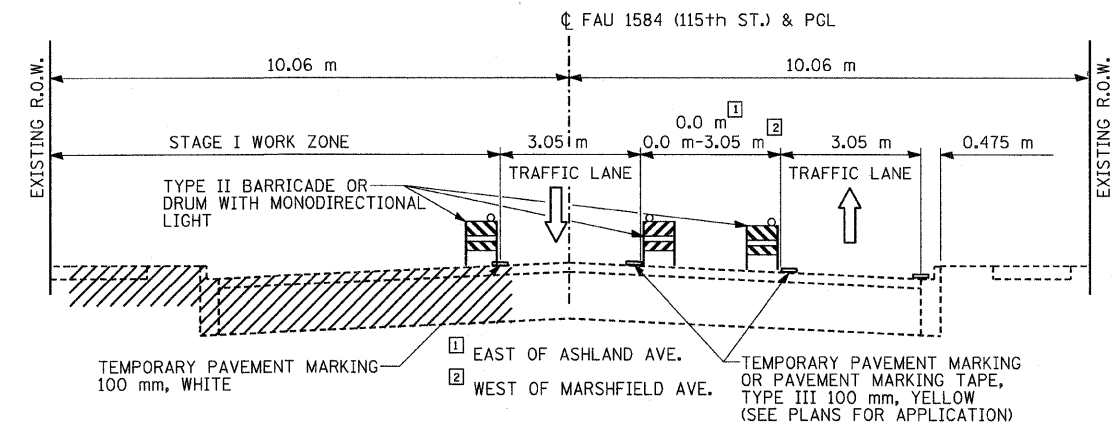

STAGE I TYPICAL ROADWAY SECTION  
(LOOKING EAST)

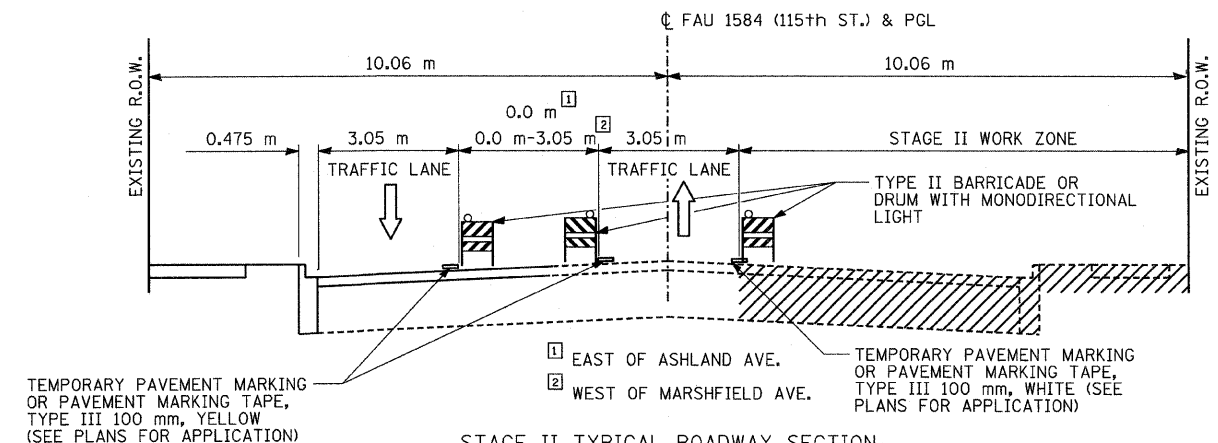

STAGE II TYPICAL ROADWAY SECTION  
(LOOKING EAST)

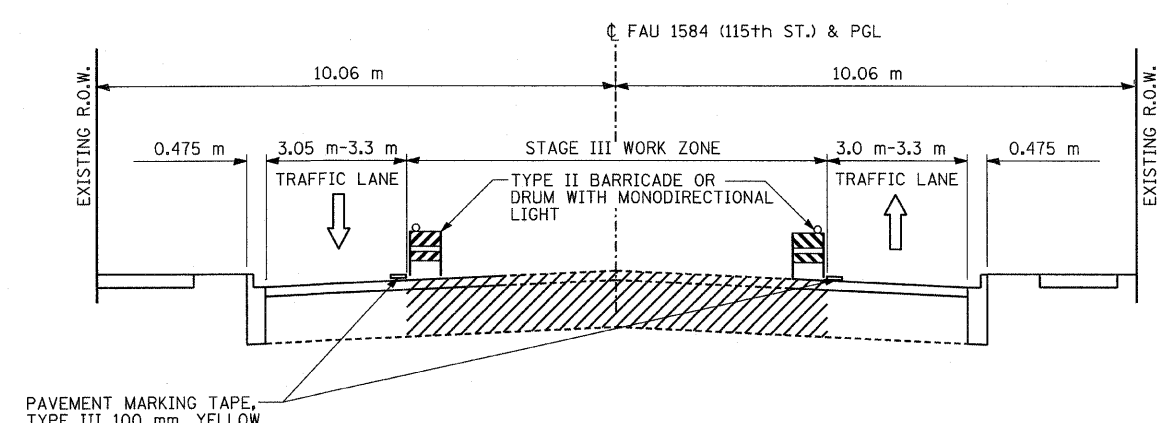

STAGE III TYPICAL ROADWAY SECTION  
(LOOKING EAST)

REVISIONS	
NAME	DATE

ILLINOIS DEPARTMENT OF TRANSPORTATION  
SUGGESTED STAGES OF CONSTRUCTION AND TRAFFIC CONTROL TYPICAL SECTIONS  
115th STREET  
SCALE: N.T.S.  
DATE: JANUARY 16, 2009  
DRAWN BY: PRH  
CHECKED BY: JMH

**COLLINS ENGINEERS**  
123 North Wacker Drive  
Suite 300  
Chicago, IL 60606  
(312) 704-9300  
www.collinsengr.com  
ILLINOIS PROFESSIONAL DESIGN FIRM LICENSE NO. 184-000993

FILE: g:\2904\civil\exhibt\2904017.dgn  
DATE: 12-Jan-09 14:48

F.A.I.	SECTION	COUNTY	TOTAL SHEETS	SHEET NO.
57	1919.2B	COOK	119	24
FED. ROAD DIST. NO.		ILLINOIS FED. AID PROJECT		CONTRACT 60371

NOTES:

- FOR ADDITIONAL DETAILS SEE "TRAFFIC CONTROL DETAILS FOR FREEWAY SHOULDER CLOSURES PARTIAL RAMP CLOSURES".
- PLACE ONE SET OF TRAFFIC CONTROL SIGNS ALONG ENTRANCE RAMP AND ANOTHER SET OF TRAFFIC CONTROL SIGNS ALONG I-57 MAINLINE.

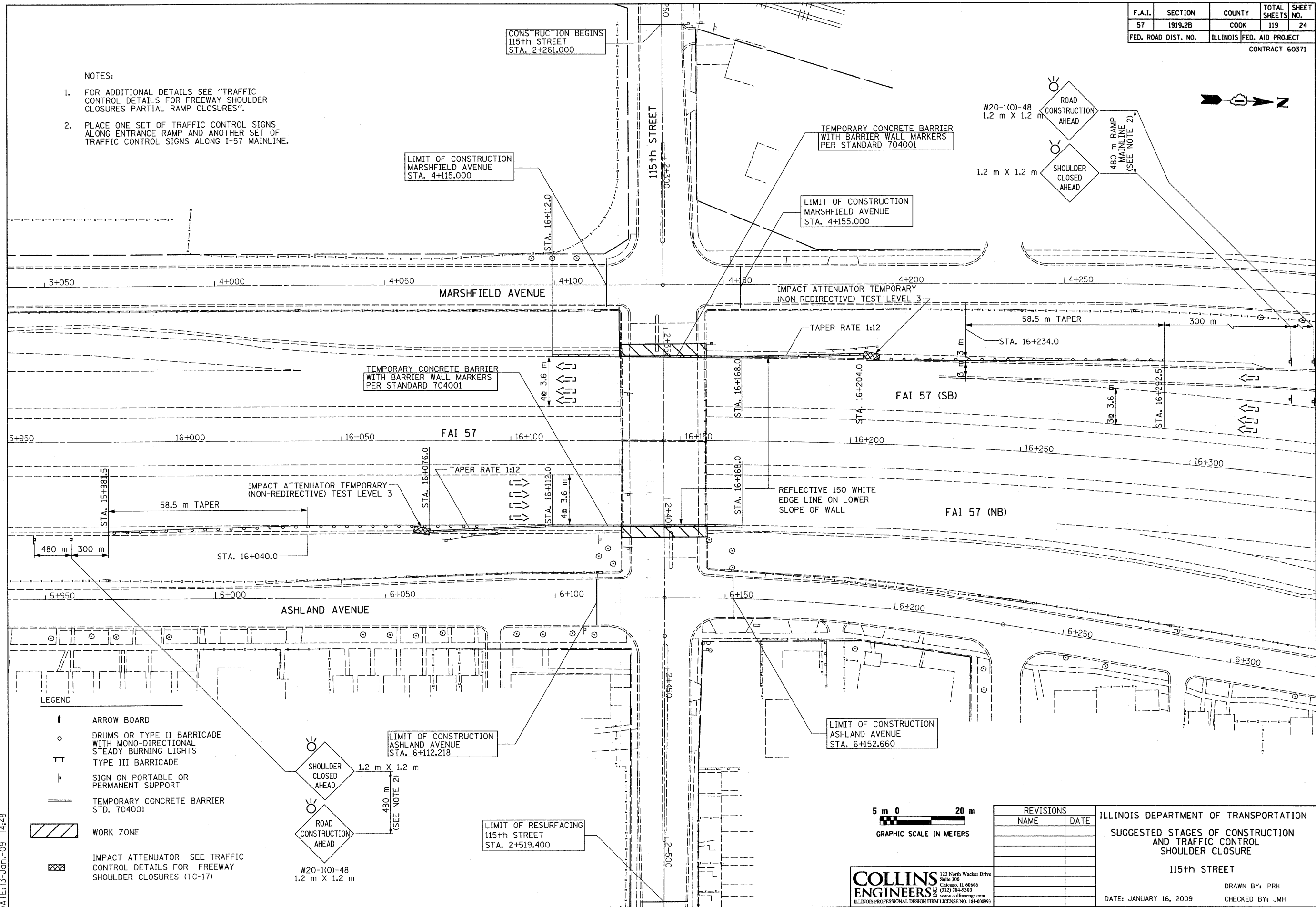

LEGEND

- ↑ ARROW BOARD
- DRUMS OR TYPE II BARRICADE WITH MONO-DIRECTIONAL STEADY BURNING LIGHTS
- ⊥ TYPE III BARRICADE
- ⊥ SIGN ON PORTABLE OR PERMANENT SUPPORT
- TEMPORARY CONCRETE BARRIER STD. 704001
- ▨ WORK ZONE
- ⊗ IMPACT ATTENUATOR SEE TRAFFIC CONTROL DETAILS FOR FREEWAY SHOULDER CLOSURES (TC-17)

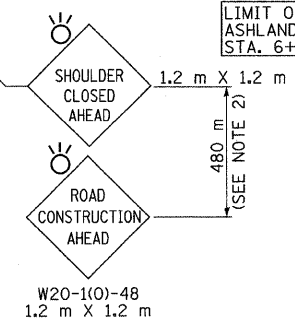

LIMIT OF CONSTRUCTION  
ASHLAND AVENUE  
STA. 6+112.218

LIMIT OF RESURFACING  
115th STREET  
STA. 2+519.400

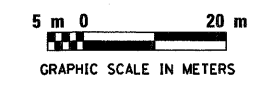

REVISIONS	
NAME	DATE

ILLINOIS DEPARTMENT OF TRANSPORTATION  
SUGGESTED STAGES OF CONSTRUCTION  
AND TRAFFIC CONTROL  
SHOULDER CLOSURE  
115th STREET  
DRAWN BY: PRH  
CHECKED BY: JMH  
DATE: JANUARY 16, 2009

**COLLINS ENGINEERS**  
123 North Wacker Drive  
Suite 300  
Chicago, IL 60606  
(312) 704-9300  
www.collinsengr.com  
ILLINOIS PROFESSIONAL DESIGN FIRM LICENSE NO. 184-000993

FILE: g:\2904\civil\exhib\1\2904018.dgn  
DATE: 13-Jan-09 14:48



F.A.I.	SECTION	COUNTY	TOTAL SHEETS	SHEET NO.
57	1919.2B	COOK	119	25
FED. ROAD DIST. NO.		ILLINOIS FED. AID PROJECT	CONTRACT 60371	

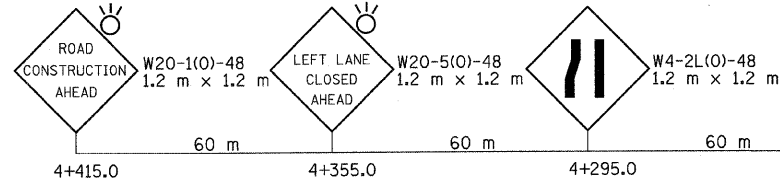

LEGEND

- ↑ ARROW BOARD
- DRUM, TYPE I, OR TYPE II BARRICADE
- ⊥ TYPE III BARRICADE (NUMBER REQUIRED AS DIRECTED BY ENGINEER FOR PROPER CLOSURE)
- ⊥ SIGN ON PORTABLE OR PERMANENT SUPPORT
- TEMPORARY CONCRETE BARRIER
- ▨ WORK ZONE
- ⊠ IMPACT ATTENUATOR SEE STANDARD 701321
- ▤ TEMPORARY SIDEWALK

PAVEMENT MARKING LEGEND

- ① TEMPORARY PAVEMENT MARKING, 100 mm SOLID WHITE
- ② TEMPORARY PAVEMENT MARKING, 100 mm DOUBLE YELLOW AT 200 mm C-C
- ③ TEMPORARY PAVEMENT MARKING, 150 mm SOLID WHITE
- ④ TEMPORARY PAVEMENT MARKING, 600 mm SOLID WHITE
- ⑤ TEMPORARY PAVEMENT MARKING, 100 mm SOLID WHITE (1.8 m DASH, 5.5 m SKIP)
- ⑥ TEMPORARY PAVEMENT MARKING, 100 mm SOLID YELLOW
- ⑦ TEMPORARY PAVEMENT MARKING, 400 mm SOLID WHITE
- ⑧ TEMPORARY PAVEMENT MARKING-LETTERS AND SYMBOLS
- ⑨ WET TEMPORARY PAVEMENT MARKING TAPE, TYPE III 100 mm SOLID WHITE
- ⑩ WET TEMPORARY PAVEMENT MARKING TAPE, TYPE III 100 mm SOLID YELLOW
- ⑪ WET TEMPORARY PAVEMENT MARKING TAPE, TYPE III 100 mm DOUBLE YELLOW @ 200 mm C-C
- ⑫ TEMPORARY PAVEMENT MARKING, 150 mm SOLID WHITE (600 mm DASH, 1.8 m SKIP)
- ⑬ WET TEMPORARY PAVEMENT MARKING TAPE, TYPE III 150 mm SOLID WHITE
- ⑭ TEMPORARY PAVEMENT MARKING, 100 mm SOLID YELLOW (600 mm DASH, 1.8 m SKIP)

NOTES:

1. MAINTAIN MINIMUM 3 m WIDE LANES.
2. PAVEMENT MARKINGS ARE PER LEGEND.
3. MAINTENANCE OF TRAFFIC AND ASSOCIATED TRAFFIC CONTROL DEVICES AND SIGNAGE SHALL BE ACCORDING TO STANDARDS 701321, 702001, 701606, 704001, 701601, 701301, 720001, 720006, 720011, 720016, 780001.
4. THE CONTRACTOR SHALL MAINTAIN ACCESS TO ONE SIDEWALK ACROSS THE BRIDGE AT ALL TIMES IN ALL STAGES. SEE STANDARD 701801.
5. TEMPORARY RAMPS SHALL BE CONSTRUCTED DURING OFF PEAK HOURS WITHIN THE INTERSECTIONS DURING AND AFTER STAGE I-A AND I-B CONSTRUCTION IN ORDER TO PROVIDE FOR ELEVATION ADJUSTMENTS DUE TO PAVEMENT RESURFACING THROUGH THE INTERSECTION.
6. CONTRACTOR TO PERFORM SUBSTRUCTURE WORK DURING STAGE I OR II BRIDGE REPAIR. CONTRACTOR MAY CLOSE THE LANE ADJACENT TO THE SHOULDER DURING OFF PEAK HOURS, AS REQUIRED.
7. ALL DRUMS AND TYPE I AND TYPE II BARRICADES SHALL BE SPACED AT 8 METERS CENTER TO CENTER ALONG ROADWAY AND 4 METERS CENTER TO CENTER AT INTERSECTIONS OR AS DIRECTED BY THE ENGINEER.
8. FOR TEMPORARY TRAFFIC SIGNAL INFORMATION SEE TEMPORARY TRAFFIC SIGNAL PLAN, SHEET NO. 45.
9. TEMPORARY SIDEWALK REMOVAL SHALL BE INCLUDED IN THE COST FOR THE PAY ITEM TEMPORARY SIDEWALK.

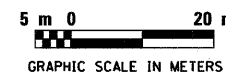
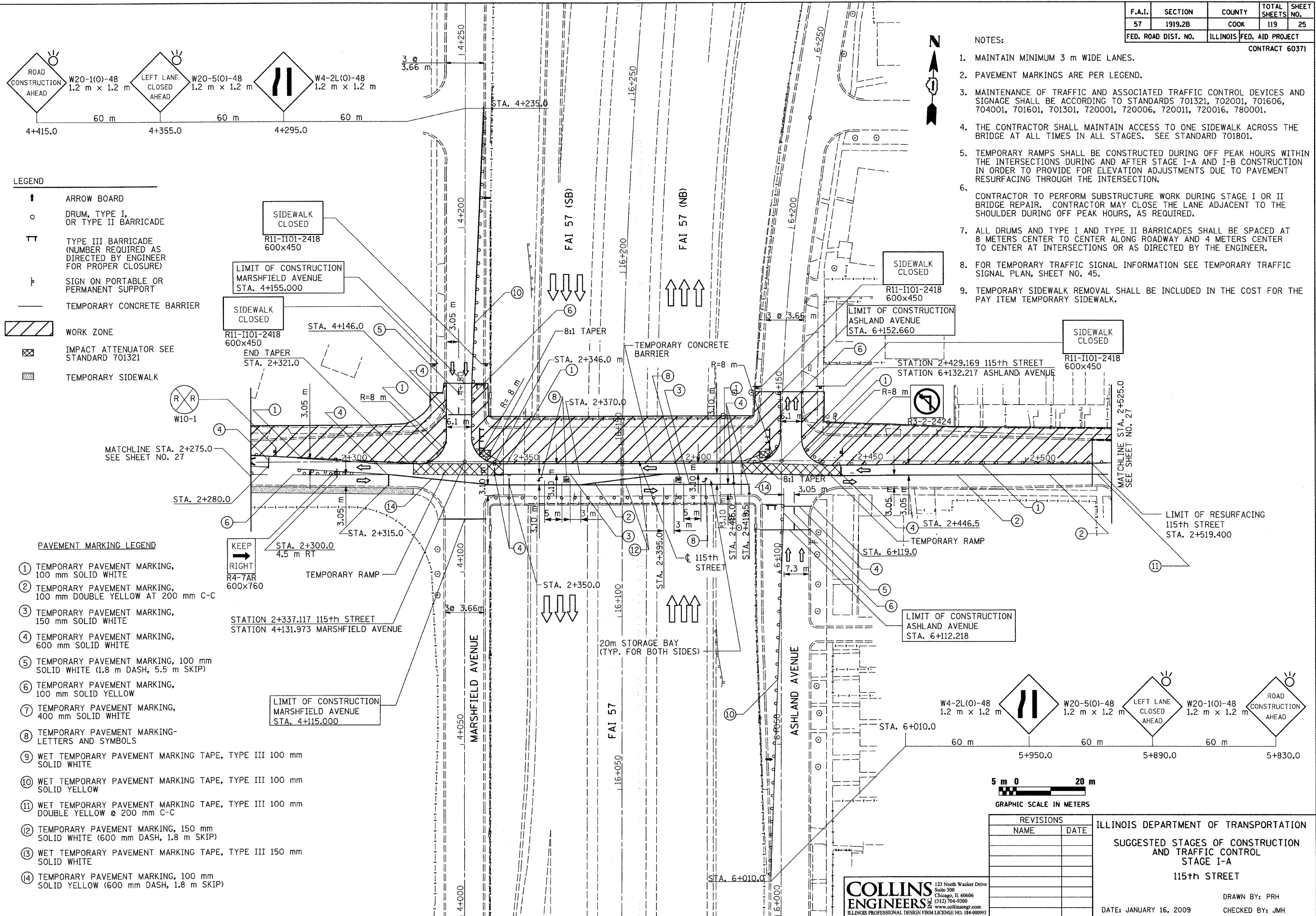

REVISIONS	
NAME	DATE

ILLINOIS DEPARTMENT OF TRANSPORTATION  
 SUGGESTED STAGES OF CONSTRUCTION  
 AND TRAFFIC CONTROL  
 STAGE I-A  
 115th STREET

DATE: JANUARY 16, 2009

DRAWN BY: PRH  
 CHECKED BY: JMH

**COLLINS ENGINEERS**  
 123 North Wacker Drive  
 Suite 300  
 Chicago, IL 60606  
 (312) 704-9300  
 www.collinsengr.com  
 ILLINOIS PROFESSIONAL DESIGN FIRM LICENSE NO. 184-000993

F.A.I.	SECTION	COUNTY	TOTAL SHEETS	SHEET NO.
57	1919.2B	COOK	119	26
FED. ROAD DIST. NO.		ILLINOIS FED. AID PROJECT	CONTRACT 60371	

NOTES:

1. MAINTAIN MINIMUM 3 m WIDE LANES.
2. PAVEMENT MARKINGS ARE PER LEGEND.
3. MAINTENANCE OF TRAFFIC AND ASSOCIATED TRAFFIC CONTROL DEVICES AND SIGNAGE SHALL BE ACCORDING TO STANDARDS 701321, 702001, 701606, 704001, 701601, 701301, 720001, 720006, 720011, 720016, 780001.
4. THE CONTRACTOR SHALL MAINTAIN ACCESS TO ONE SIDEWALK ACROSS THE BRIDGE AT ALL TIMES IN ALL STAGES. SEE STANDARD 701801.
5. TEMPORARY RAMPS SHALL BE CONSTRUCTED DURING OFF PEAK HOURS WITHIN THE INTERSECTIONS DURING AND AFTER STAGE I-A AND I-B CONSTRUCTION IN ORDER TO PROVIDE FOR ELEVATION ADJUSTMENTS DUE TO PAVEMENT RESURFACING THROUGH THE INTERSECTION.
6. CONTRACTOR TO PERFORM SUBSTRUCTURE WORK DURING STAGE I OR II BRIDGE REPAIR. CONTRACTOR MAY CLOSE THE LANE ADJACENT TO THE SHOULDER DURING OFF PEAK HOURS, AS REQUIRED.
7. ALL DRUMS AND TYPE I AND TYPE II BARRICADES SHALL BE SPACED AT 8 METERS CENTER TO CENTER ALONG ROADWAY AND 4 METERS CENTER TO CENTER AT INTERSECTIONS OR AS DIRECTED BY THE ENGINEER.
8. FOR TEMPORARY TRAFFIC SIGNAL INFORMATION SEE TEMPORARY TRAFFIC SIGNAL PLAN, SHEET NO. 45.
9. TEMPORARY SIDEWALK REMOVAL SHALL BE INCLUDED IN THE COST FOR THE PAY ITEM TEMPORARY SIDEWALK.

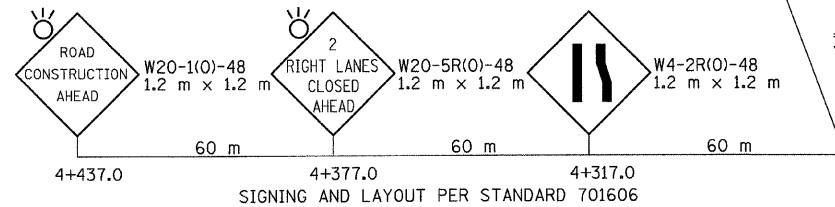

LEGEND

- ↑ ARROW BOARD
- DRUM, TYPE I, OR TYPE II BARRICADE
- TT TYPE III BARRICADE (NUMBER REQUIRED AS DIRECTED BY ENGINEER FOR PROPER CLOSURE)
- h SIGN ON PORTABLE OR PERMANENT SUPPORT
- TEMPORARY CONCRETE BARRIER
- ▨ WORK ZONE
- ⊠ IMPACT ATTENUATOR SEE STANDARD 701321
- ▤ TEMPORARY SIDEWALK

PAVEMENT MARKING LEGEND

- ① TEMPORARY PAVEMENT MARKING, 100 mm SOLID WHITE
- ② TEMPORARY PAVEMENT MARKING, 100 mm DOUBLE YELLOW AT 200 mm C-C
- ③ TEMPORARY PAVEMENT MARKING, 150 mm SOLID WHITE
- ④ TEMPORARY PAVEMENT MARKING, 600 mm SOLID WHITE
- ⑤ TEMPORARY PAVEMENT MARKING, 100 mm SOLID WHITE (1.8 m DASH, 5.5 m SKIP)
- ⑥ TEMPORARY PAVEMENT MARKING, 100 mm SOLID YELLOW
- ⑦ TEMPORARY PAVEMENT MARKING, 400 mm SOLID WHITE
- ⑧ TEMPORARY PAVEMENT MARKING-LETTERS AND SYMBOLS
- ⑨ WET TEMPORARY PAVEMENT MARKING TAPE, TYPE III 100 mm SOLID WHITE
- ⑩ WET TEMPORARY PAVEMENT MARKING TAPE, TYPE III 100 mm SOLID YELLOW
- ⑪ WET TEMPORARY PAVEMENT MARKING TAPE, TYPE III 100 mm DOUBLE YELLOW @ 200 mm C-C
- ⑫ TEMPORARY PAVEMENT MARKING, 150 mm SOLID WHITE (600 mm DASH, 1.8 m SKIP)
- ⑬ WET TEMPORARY PAVEMENT MARKING TAPE, TYPE III 150 mm SOLID WHITE
- ⑭ TEMPORARY PAVEMENT MARKING, 100 mm SOLID YELLOW (600 mm DASH, 1.8 m SKIP)
- ⑮ WET TEMPORARY PAVEMENT MARKING TAPE, TYPE III 600 mm, SOLID WHITE

MATCHLINE STA. 2+275.0  
SEE SHEET NO. 27

MATCHLINE STA. 2+525.0  
SEE SHEET NO. 27

STATION 2+337.117 115th STREET  
STATION 4+131.973 MARSHFIELD AVENUE

LIMIT OF CONSTRUCTION  
MARSHFIELD AVENUE  
STA. 4+115.000

LIMIT OF CONSTRUCTION  
ASHLAND AVENUE  
STA. 6+112.218

LIMIT OF RESURFACING  
115TH STREET  
STA. 2+519.400

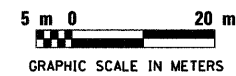
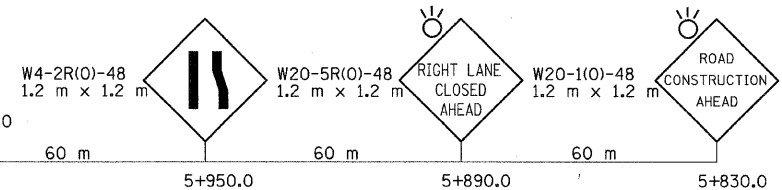

REVISIONS	
NAME	DATE

ILLINOIS DEPARTMENT OF TRANSPORTATION  
SUGGESTED STAGES OF CONSTRUCTION  
AND TRAFFIC CONTROL  
STAGE I-B  
115th STREET

DRAWN BY: PRH  
CHECKED BY: JMH

DATE: JANUARY 16, 2009

**COLLINS ENGINEERS**  
123 North Wacker Drive  
Suite 300  
Chicago, IL 60606  
(312) 704-9300  
www.collinsengr.com  
ILLINOIS PROFESSIONAL DESIGN FIRM LICENSE NO. 184-000993

FILE: g:\2904\civil\exhibit\2904020.dgn  
DATE: 13-Jan-09 14:48

F.A.I.	SECTION	COUNTY	TOTAL SHEETS	SHEET NO.
57	1919.2B	COOK	119	27
FED. ROAD DIST. NO.		ILLINOIS FED. AID PROJECT		CONTRACT 60371

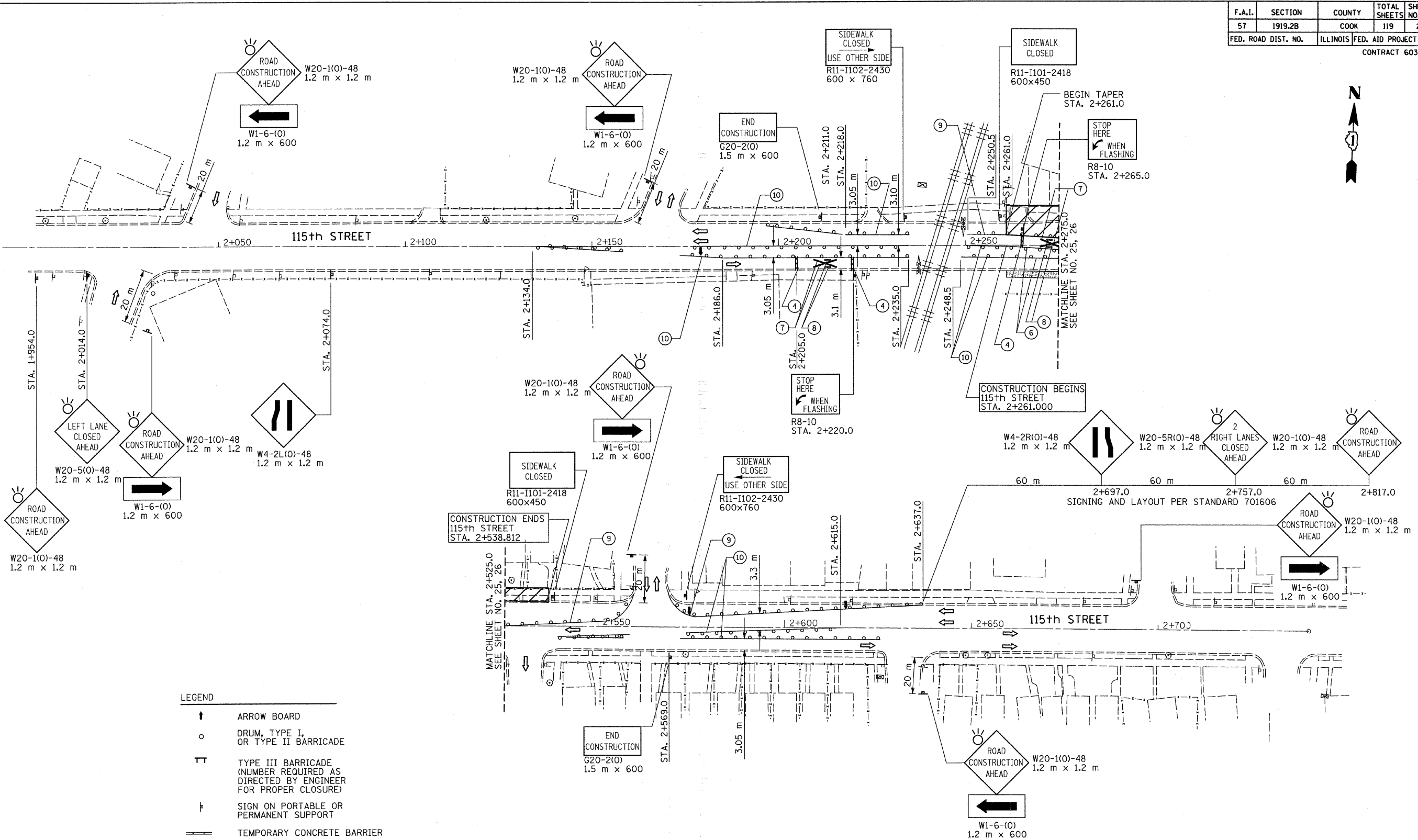

- LEGEND**
- ↑ ARROW BOARD
  - DRUM, TYPE I, OR TYPE II BARRICADE
  - ⊥ TYPE III BARRICADE (NUMBER REQUIRED AS DIRECTED BY ENGINEER FOR PROPER CLOSURE)
  - ⊥ SIGN ON PORTABLE OR PERMANENT SUPPORT
  - TEMPORARY CONCRETE BARRIER
  - ▨ WORK ZONE
  - ⊠ IMPACT ATTENUATOR SEE STANDARD 701321
  - ▨ TEMPORARY SIDEWALK

NOTE:  
FOR NOTES AND PAVEMENT MARKING  
LEGEND, SEE SHEET NO. 25, 26

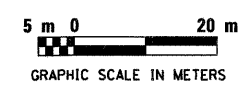

REVISIONS	
NAME	DATE

ILLINOIS DEPARTMENT OF TRANSPORTATION  
SUGGESTED STAGES OF CONSTRUCTION  
AND TRAFFIC CONTROL  
STAGE I-A & STAGE I-B  
**115th STREET**

DATE: JANUARY 16, 2009

DRAWN BY: PRH  
CHECKED BY: JMH

**COLLINS ENGINEERS**  
123 North Wacker Drive  
Suite 200  
Chicago, IL 60606  
(312) 704-9300  
www.collinsengr.com  
ILLINOIS PROFESSIONAL DESIGN FIRM LICENSE NO. 184-000993

FILE: g:\2904\civil\115th\115th\2904021.dgn  
DATE: 15-Jan-09 14:48

F.A.I.	SECTION	COUNTY	TOTAL SHEETS	SHEET NO.
57	1919.2B	COOK	119	28
FED. ROAD DIST. NO.		ILLINOIS FED. AID PROJECT		CONTRACT 60371

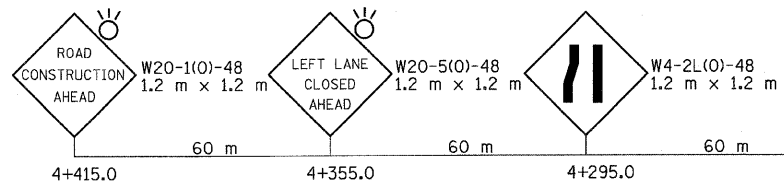

- LEGEND**
- ↑ ARROW BOARD
  - DRUM, TYPE I, OR TYPE II BARRICADE
  - TT TYPE III BARRICADE (NUMBER REQUIRED AS DIRECTED BY ENGINEER FOR PROPER CLOSURE)
  - h SIGN ON PORTABLE OR PERMANENT SUPPORT
  - TEMPORARY CONCRETE BARRIER
  - ▨ WORK ZONE
  - ⊠ IMPACT ATTENUATOR

- NOTES:**
- MAINTAIN MINIMUM 3 m WIDE LANES.
  - PAVEMENT MARKINGS ARE PER LEGEND.
  - MAINTENANCE OF TRAFFIC AND ASSOCIATED TRAFFIC CONTROL DEVICES AND SIGNAGE SHALL BE ACCORDING TO STANDARDS 701321, 702001, 701606, 704001, 701601, 701301, 720001, 720006, 720011, 720016, 780001.
  - THE CONTRACTOR SHALL MAINTAIN ACCESS TO ONE SIDEWALK ACROSS THE BRIDGE AT ALL TIMES IN ALL STAGES. SEE STANDARD 701801.
  - TEMPORARY RAMPS SHALL BE CONSTRUCTED DURING OFF PEAK HOURS WITHIN THE INTERSECTIONS DURING AND AFTER STAGE II-A AND II-B CONSTRUCTION IN ORDER TO PROVIDE FOR ELEVATION ADJUSTMENTS DUE TO PAVEMENT RESURFACING THROUGH THE INTERSECTION.
  - CONTRACTOR TO PERFORM SUBSTRUCTURE WORK DURING STAGE I OR II BRIDGE REPAIR. CONTRACTOR MAY CLOSE THE LANE ADJACENT TO THE SHOULDER DURING OFF PEAK HOURS, AS REQUIRED.
  - ALL DRUMS AND TYPE I AND TYPE II BARRICADES SHALL BE SPACED AT 8 METERS CENTER TO CENTER ALONG ROADWAY AND 4 METERS CENTER TO CENTER AT INTERSECTIONS OR AS DIRECTED BY THE ENGINEER.
  - FOR TEMPORARY TRAFFIC SIGNAL INFORMATION SEE TEMPORARY TRAFFIC SIGNAL PLAN, SHEET NO. 46.
  - TEMPORARY SIDEWALK REMOVAL SHALL BE INCLUDED IN THE COST FOR THE PAY ITEM TEMPORARY SIDEWALK.

**PAVEMENT MARKING LEGEND**

- TEMPORARY PAVEMENT MARKING, 100 mm SOLID WHITE
- TEMPORARY PAVEMENT MARKING, 100 mm DOUBLE YELLOW AT 200 mm C-C
- TEMPORARY PAVEMENT MARKING, 100 mm SOLID WHITE (1.8 m DASH, 5.5 m SKIP)
- TEMPORARY PAVEMENT MARKING, 600 mm SOLID WHITE
- TEMPORARY PAVEMENT MARKING, 100 mm SOLID WHITE (600 mm DASH, 1.8 m SKIP)
- TEMPORARY PAVEMENT MARKING, 100 mm SOLID YELLOW
- TEMPORARY PAVEMENT MARKING, 400 mm SOLID WHITE
- TEMPORARY PAVEMENT MARKING-LETTERS AND SYMBOLS
- WET TEMPORARY PAVEMENT MARKING TAPE, TYPE III 100 mm SOLID WHITE
- WET TEMPORARY PAVEMENT MARKING TAPE, TYPE III 100 mm SOLID YELLOW
- WET TEMPORARY PAVEMENT MARKING TAPE, TYPE III 100 mm DOUBLE YELLOW @ 200 mm C-C
- WET TEMPORARY PAVEMENT MARKING TAPE, TYPE III 150 mm SOLID WHITE (600 mm DASH, 1.8 m SKIP)
- WET TEMPORARY PAVEMENT MARKING TAPE, TYPE III 150 mm SOLID WHITE
- WET TEMPORARY PAVEMENT MARKING TAPE, TYPE III 100 mm SOLID YELLOW (600 mm DASH, 1.8 m SKIP)
- WET TEMPORARY PAVEMENT MARKING TAPE, TYPE III 600 mm SOLID WHITE
- WET TEMPORARY PAVEMENT MARKING TAPE, TYPE III LETTERS AND SYMBOLS
- WET TEMPORARY PAVEMENT MARKING TAPE, TYPE III 300 mm SOLID WHITE
- WET TEMPORARY PAVEMENT MARKING TAPE, TYPE III 100 mm SOLID WHITE (1.8 m DASH, 5.5 m SKIP)

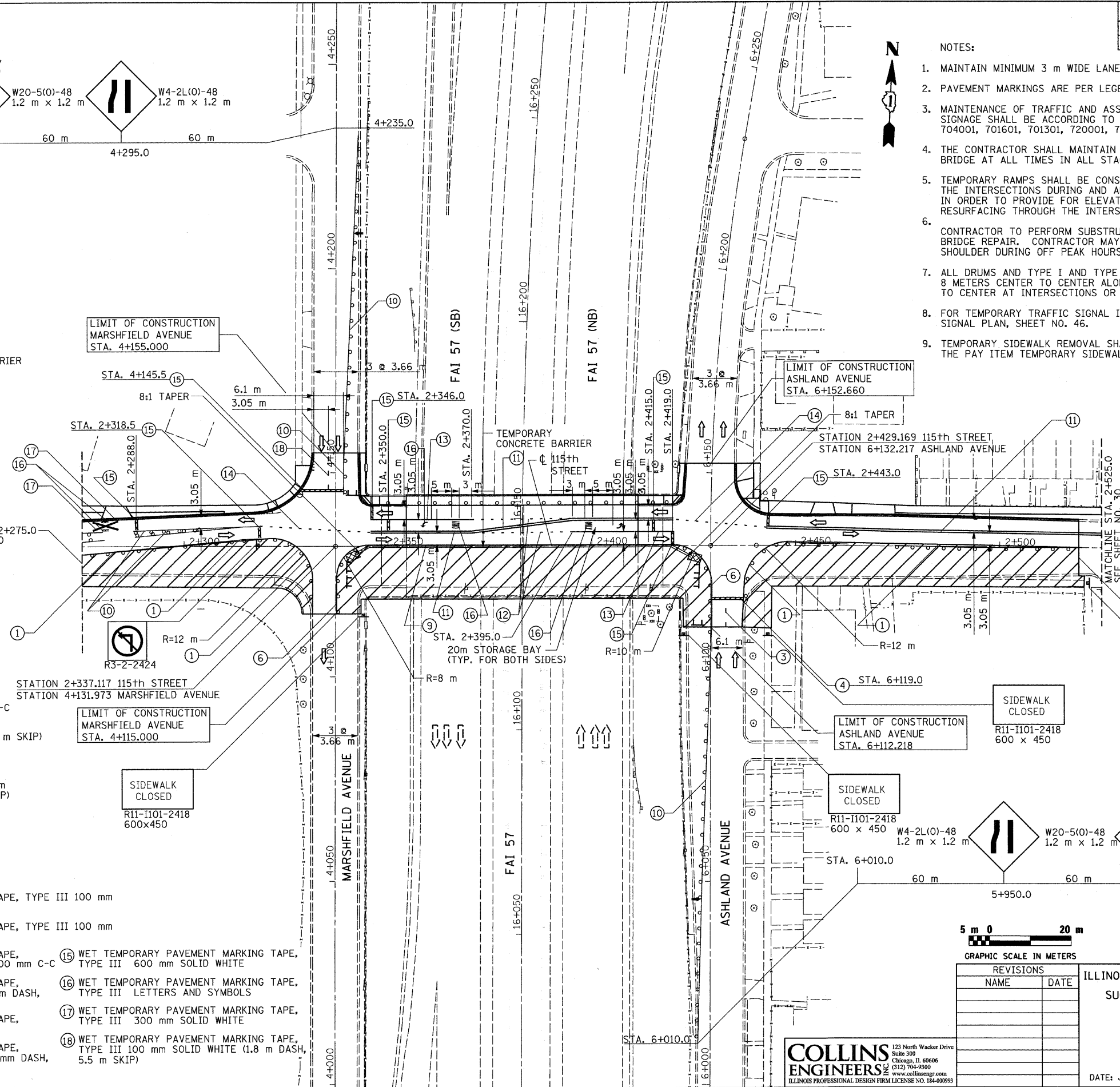

**COLLINS ENGINEERS**  
 123 North Wacker Drive  
 Suite 300  
 Chicago, IL 60606  
 (312) 704-9300  
 www.collinsengr.com  
 ILLINOIS PROFESSIONAL DESIGN FIRM LICENSE NO. 184-000993



REVISIONS	
NAME	DATE

ILLINOIS DEPARTMENT OF TRANSPORTATION  
 SUGGESTED STAGES OF CONSTRUCTION AND TRAFFIC CONTROL  
 STAGE II-A  
 115th STREET  
 DRAWN BY: PRH  
 CHECKED BY: JMH  
 DATE: JANUARY 16, 2009

FILE: g:\2904\civil\exhibits\2904022.dgn  
 DATE: 13-Jun-09 14:24

F.A.I.	SECTION	COUNTY	TOTAL SHEET
57	1919.2B	COOK	119
FED. ROAD DIST. NO.	ILLINOIS	FED. AID PROJECT	CONTRACT 60371

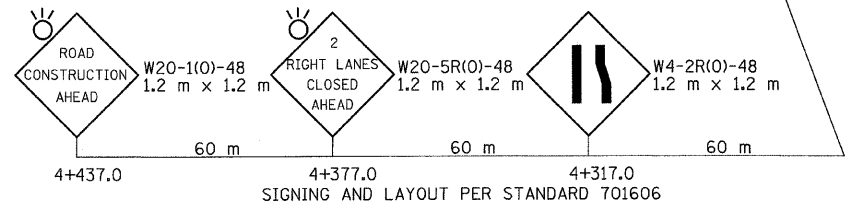

- LEGEND**
- ↑ ARROW BOARD
  - DRUM, TYPE I, OR TYPE II BARRICADE
  - ▭ TYPE III BARRICADE (NUMBER REQUIRED AS DIRECTED BY ENGINEER FOR PROPER CLOSURE)
  - ⊥ SIGN ON PORTABLE OR PERMANENT SUPPORT
  - ▬ TEMPORARY CONCRETE BARRIER
  - ▨ WORK ZONE
  - ⊠ IMPACT ATTENUATOR SEE STANDARD 701321

- NOTES:**
- MAINTAIN MINIMUM 3 m WIDE LANES.
  - PAVEMENT MARKINGS ARE PER LEGEND.
  - MAINTENANCE OF TRAFFIC AND ASSOCIATED TRAFFIC CONTROL DEVICES AND SIGNAGE SHALL BE ACCORDING TO STANDARDS 701321, 702001, 701606, 704001, 701601, 701301, 720001, 720006, 720011, 720016, 780001.
  - THE CONTRACTOR SHALL MAINTAIN ACCESS TO ONE SIDEWALK ACROSS THE BRIDGE AT ALL TIMES IN ALL STAGES. SEE STANDARD 701801.
  - TEMPORARY RAMPS SHALL BE CONSTRUCTED DURING OFF PEAK HOURS WITHIN THE INTERSECTIONS DURING AND AFTER STAGE II-A AND II-B CONSTRUCTION IN ORDER TO PROVIDE FOR ELEVATION ADJUSTMENTS DUE TO PAVEMENT RESURFACING THROUGH THE INTERSECTION.
  - CONTRACTOR TO PERFORM SUBSTRUCTURE WORK DURING STAGE I OR II BRIDGE REPAIR. CONTRACTOR MAY CLOSE THE LANE ADJACENT TO THE SHOULDER DURING OFF PEAK HOURS, AS REQUIRED.
  - ALL DRUMS AND TYPE I AND TYPE II BARRICADES SHALL BE SPACED AT 8 METERS CENTER TO CENTER ALONG ROADWAY AND 4 METERS CENTER TO CENTER AT INTERSECTIONS OR AS DIRECTED BY THE ENGINEER.
  - FOR TEMPORARY TRAFFIC SIGNAL INFORMATION SEE TEMPORARY TRAFFIC SIGNAL PLAN, SHEET NO. 46.

- PAVEMENT MARKING LEGEND**
- TEMPORARY PAVEMENT MARKING, 100 mm SOLID WHITE
  - TEMPORARY PAVEMENT MARKING, 100 mm DOUBLE YELLOW AT 200 mm C-C
  - TEMPORARY PAVEMENT MARKING, 100 mm SOLID WHITE (1.8 m DASH, 5.5 m SKIP)
  - TEMPORARY PAVEMENT MARKING, 600 mm SOLID WHITE
  - TEMPORARY PAVEMENT MARKING, 100 mm SOLID WHITE (600 mm DASH, 1.8 m SKIP)
  - TEMPORARY PAVEMENT MARKING, 100 mm SOLID YELLOW
  - TEMPORARY PAVEMENT MARKING, 400 mm SOLID WHITE
  - TEMPORARY PAVEMENT MARKING-LETTERS AND SYMBOLS
  - WET TEMPORARY PAVEMENT MARKING TAPE, TYPE III 100 mm SOLID WHITE
  - WET TEMPORARY PAVEMENT MARKING TAPE, TYPE III 100 mm SOLID YELLOW
  - WET TEMPORARY PAVEMENT MARKING TAPE, TYPE III 100 mm DOUBLE YELLOW @ 200 mm C-C
  - WET TEMPORARY PAVEMENT MARKING TAPE, TYPE III 150 mm SOLID WHITE (600 mm DASH, 1.8 m SKIP)
  - WET TEMPORARY PAVEMENT MARKING TAPE, TYPE III 150 mm SOLID WHITE
  - WET TEMPORARY PAVEMENT MARKING TAPE, TYPE III 100 mm SOLID WHITE (1.8 m DASH, 5.5 m SKIP)
  - WET TEMPORARY PAVEMENT MARKING TAPE, TYPE III 600 mm SOLID WHITE
  - WET TEMPORARY PAVEMENT MARKING TAPE, TYPE III LETTERS AND SYMBOLS
  - WET TEMPORARY PAVEMENT MARKING TAPE, TYPE III 300 mm SOLID WHITE
  - WET TEMPORARY PAVEMENT MARKING TAPE, TYPE III 100 mm SOLID WHITE (1.8 m DASH, 5.5 m SKIP)

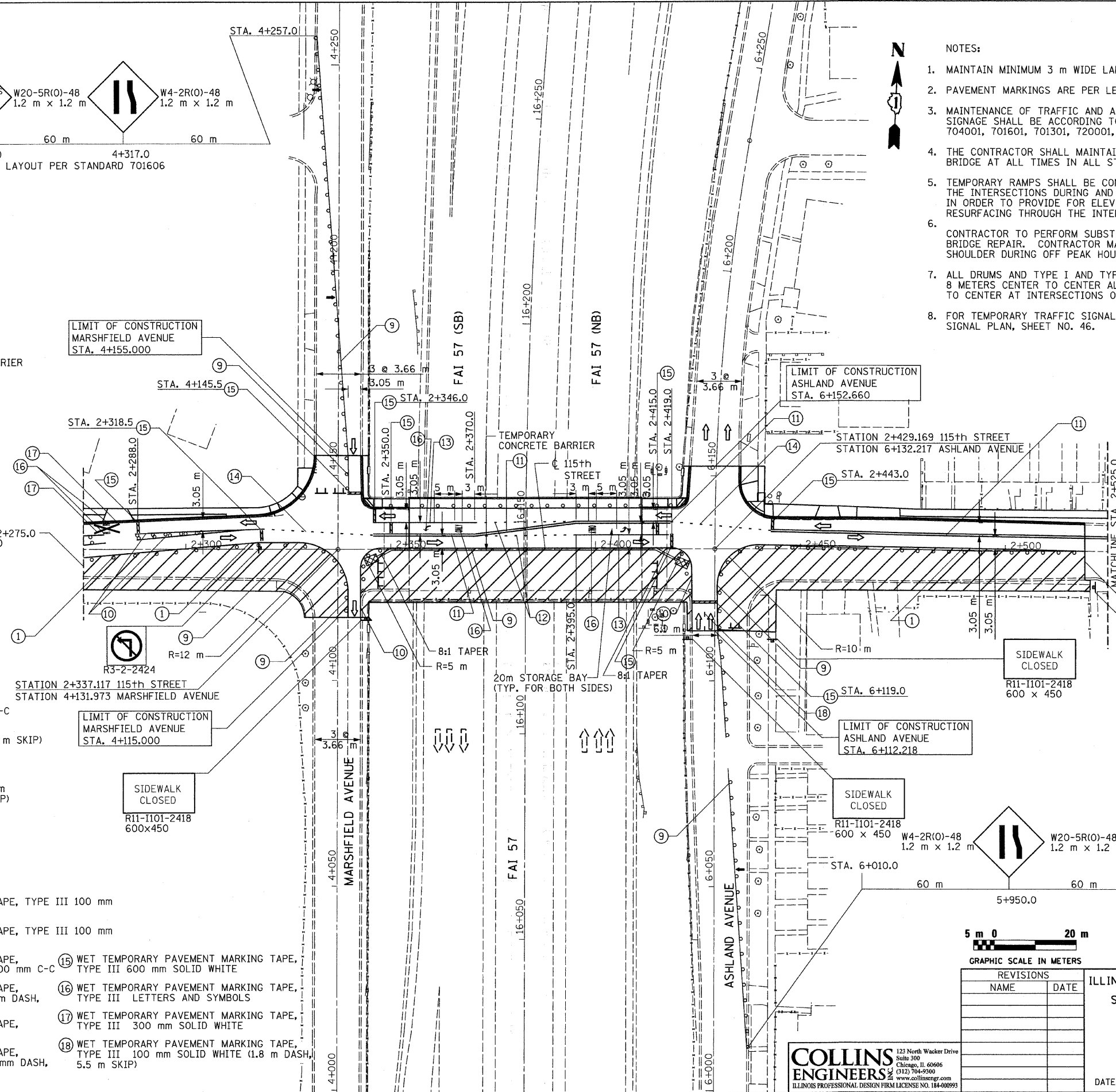

**COLLINS ENGINEERS**  
 123 North Wacker Drive  
 Suite 300  
 Chicago, IL 60606  
 (312) 704-9300  
 www.collinsengr.com  
 ILLINOIS PROFESSIONAL DESIGN FIRM LICENSE NO. 184-000993



REVISIONS	
NAME	DATE

ILLINOIS DEPARTMENT OF TRANSPORTATION  
 SUGGESTED STAGES OF CONSTRUCTION AND TRAFFIC CONTROL  
 STAGE II-B  
 115th STREET  
 DRAWN BY: PRH  
 CHECKED BY: JMH  
 DATE: JANUARY 16, 2009

FILE: g:\2304\civil\exhibit\2304023.dgn  
 DATE: 13-Jan-09 14:24

F.A.I.	SECTION	COUNTY	TOTAL SHEETS	SHEET NO.
57	1919.2B	COOK	119	30
FED. ROAD DIST. NO.		ILLINOIS	FED. AID PROJECT	
CONTRACT 60371				

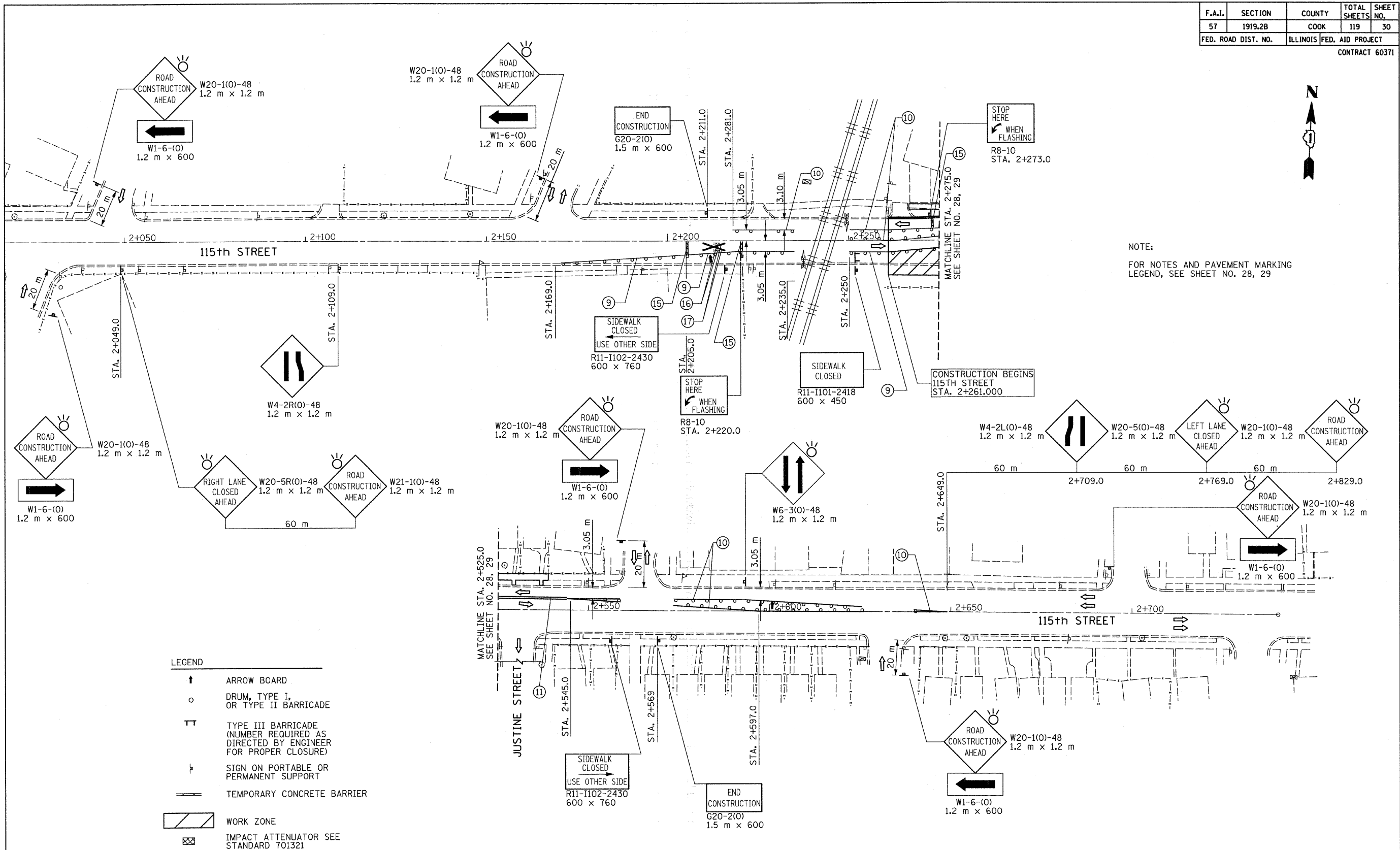

NOTE:  
FOR NOTES AND PAVEMENT MARKING  
LEGEND, SEE SHEET NO. 28, 29

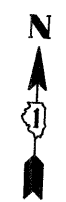

**LEGEND**

	ARROW BOARD
	DRUM, TYPE I, OR TYPE II BARRICADE
	TYPE III BARRICADE (NUMBER REQUIRED AS DIRECTED BY ENGINEER FOR PROPER CLOSURE)
	SIGN ON PORTABLE OR PERMANENT SUPPORT
	TEMPORARY CONCRETE BARRIER
	WORK ZONE
	IMPACT ATTENUATOR SEE STANDARD 701321

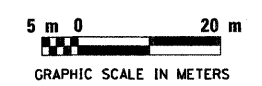

REVISIONS	
NAME	DATE

**COLLINS ENGINEERS**  
123 North Wacker Drive  
Suite 300  
Chicago, IL 60606  
(312) 704-9300  
www.collinsengr.com  
ILLINOIS PROFESSIONAL DESIGN FIRM LICENSE NO. 184-000993

ILLINOIS DEPARTMENT OF TRANSPORTATION  
SUGGESTED STAGES OF CONSTRUCTION  
AND TRAFFIC CONTROL  
STAGE II-A & STAGE II-B  
115th STREET

DATE: JANUARY 16, 2009

DRAWN BY: PRH  
CHECKED BY: JMH

FILE: g:\2804\civil\exhib\1\2804024.dgn  
DATE: 15-jan-09 14:24

F.A.I.	SECTION	COUNTY	TOTAL SHEETS	SHEET NO.
57	1919.2B	COOK	119	31
FED. ROAD DIST. NO.		ILLINOIS	FED. AID PROJECT	
CONTRACT 60371				



**NOTES:**

1. MAINTAIN MINIMUM 3 m WIDE LANES.
2. PAVEMENT MARKINGS ARE PER LEGEND.
3. MAINTENANCE OF TRAFFIC AND ASSOCIATED TRAFFIC CONTROL DEVICES AND SIGNAGE SHALL BE ACCORDING TO STANDARDS 701321, 702001, 701606, 704001, 701601, 701301, 720001, 720006, 720011, 720016, 780001.
4. THE CONTRACTOR SHALL MAINTAIN ACCESS TO ONE SIDEWALK ACROSS THE BRIDGE AT ALL TIMES IN ALL STAGES. SEE STANDARD 701801.
5. ALL DRUMS AND TYPE I AND TYPE II BARRICADES SHALL BE SPACED AT 8 METERS CENTER TO CENTER ALONG ROADWAY AND 4 METERS CENTER TO CENTER AT INTERSECTIONS OR AS DIRECTED BY THE ENGINEER.
6. FOR TEMPORARY TRAFFIC SIGNAL INFORMATION SEE TEMPORARY TRAFFIC SIGNAL PLAN, SHEET NO. 46.

**PAVEMENT MARKING LEGEND**

- ① TEMPORARY PAVEMENT MARKING, 100 mm SOLID WHITE
- ② TEMPORARY PAVEMENT MARKING, 100 mm DOUBLE YELLOW AT 200 mm C-C
- ③ TEMPORARY PAVEMENT MARKING, 150 mm SOLID WHITE
- ④ TEMPORARY PAVEMENT MARKING, 600 mm SOLID WHITE
- ⑤ TEMPORARY PAVEMENT MARKING, 100 mm SOLID WHITE (600 mm DASH, 1.8m SKIP)
- ⑥ TEMPORARY PAVEMENT MARKING, 100 mm SOLID YELLOW
- ⑦ TEMPORARY PAVEMENT MARKING, 400 mm SOLID WHITE
- ⑧ TEMPORARY PAVEMENT MARKING- LETTERS AND SYMBOLS
- ⑨ WET TEMPORARY PAVEMENT MARKING TAPE, TYPE III 100 mm SOLID WHITE
- ⑩ WET TEMPORARY PAVEMENT MARKING TAPE, TYPE III 100 mm SOLID YELLOW
- ⑪ WET TEMPORARY PAVEMENT MARKING TAPE, TYPE III 100 mm DOUBLE YELLOW @ 200 mm C-C
- ⑫ WET TEMPORARY PAVEMENT MARKING TAPE, TYPE III 100 mm SOLID WHITE (1.8 m DASH, 5.5 m SKIP)
- ⑬ WET TEMPORARY PAVEMENT MARKING TAPE, TYPE III 150 mm SOLID WHITE
- ⑭ WET TEMPORARY PAVEMENT MARKING TAPE, TYPE III 150 mm SOLID WHITE (600 mm DASH, 1.8 m SKIP)
- ⑮ WET TEMPORARY PAVEMENT MARKING TAPE, TYPE III 600 mm, SOLID WHITE
- ⑯ WET TEMPORARY PAVEMENT MARKING TAPE, TYPE III LETTERS AND SYMBOLS
- ⑰ WET TEMPORARY PAVEMENT MARKING TAPE, TYPE III 300 mm SOLID WHITE

**LEGEND**

- ↑ ARROW BOARD
- DRUM, TYPE I, OR TYPE II BARRICADE
- ⊥ TYPE III BARRICADE (NUMBER REQUIRED AS DIRECTED BY ENGINEER FOR PROPER CLOSURE)
- ⊥ SIGN ON PORTABLE OR PERMANENT SUPPORT
- ▬ TEMPORARY CONCRETE BARRIER
- ▨ WORK ZONE
- ⊠ IMPACT ATTENUATOR SEE STANDARD 701321

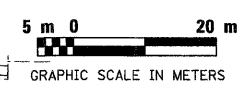

REVISIONS	
NAME	DATE

**COLLINS ENGINEERS**  
123 North Wacker Drive  
Suite 300  
Chicago, IL 60606  
(312) 704-9300  
www.collinsengr.com  
ILLINOIS PROFESSIONAL DESIGN FIRM LICENSE NO. 184-000993

ILLINOIS DEPARTMENT OF TRANSPORTATION  
SUGGESTED STAGES OF CONSTRUCTION  
AND TRAFFIC CONTROL  
STAGE III  
**115th STREET**  
DRAWN BY: PRH  
CHECKED BY: JMH  
DATE: JANUARY 16, 2009

FILE: C:\2904\civil\exhibit\2904025.dgn  
DATE: 15-JUN-09 14:24

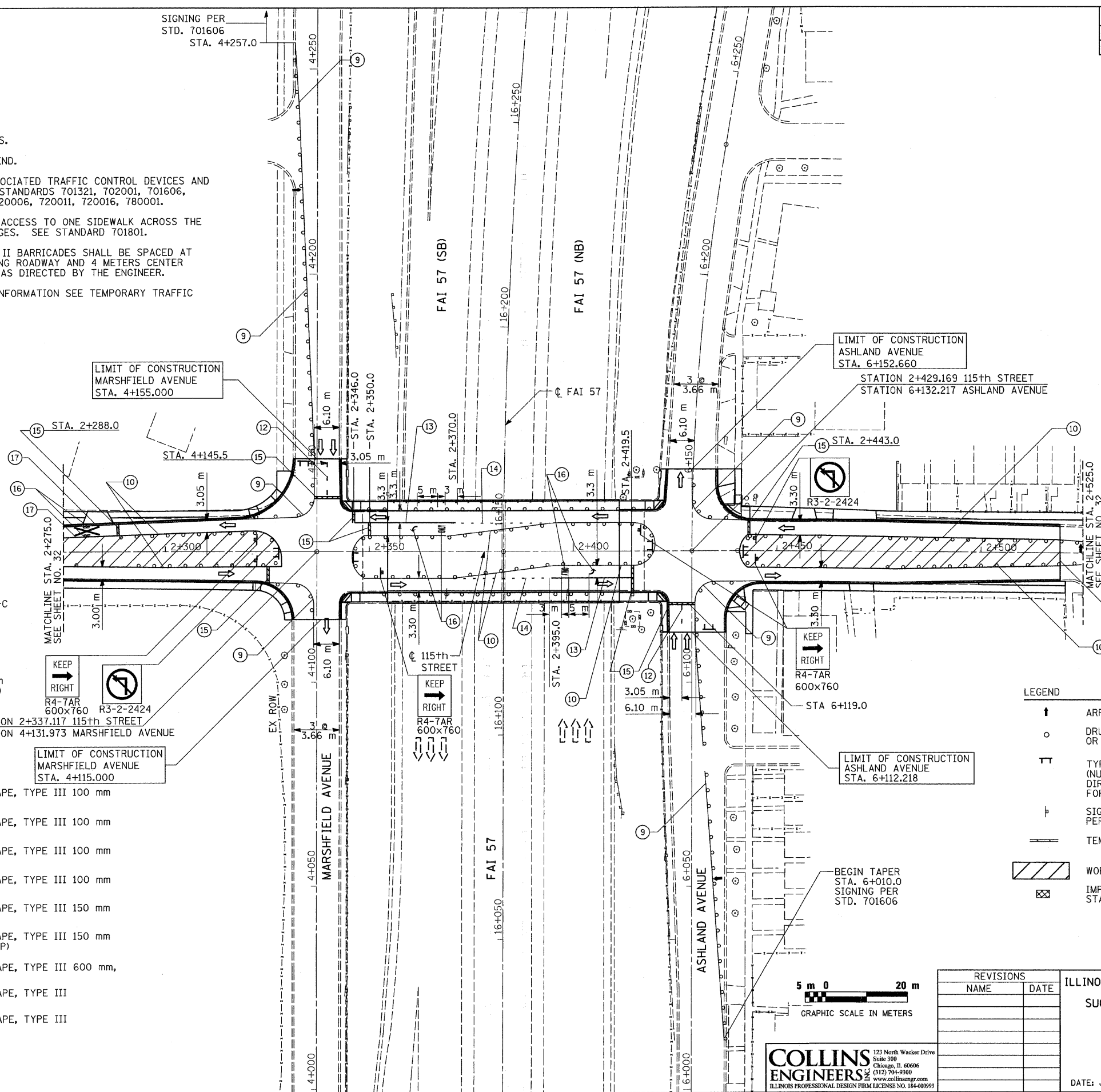

F.A.I.	SECTION	COUNTY	TOTAL SHEETS	SHEET NO.
57	1919.2B	COOK	119	32
FED. ROAD DIST. NO.		ILLINOIS FED. AID PROJECT		CONTRACT 60371

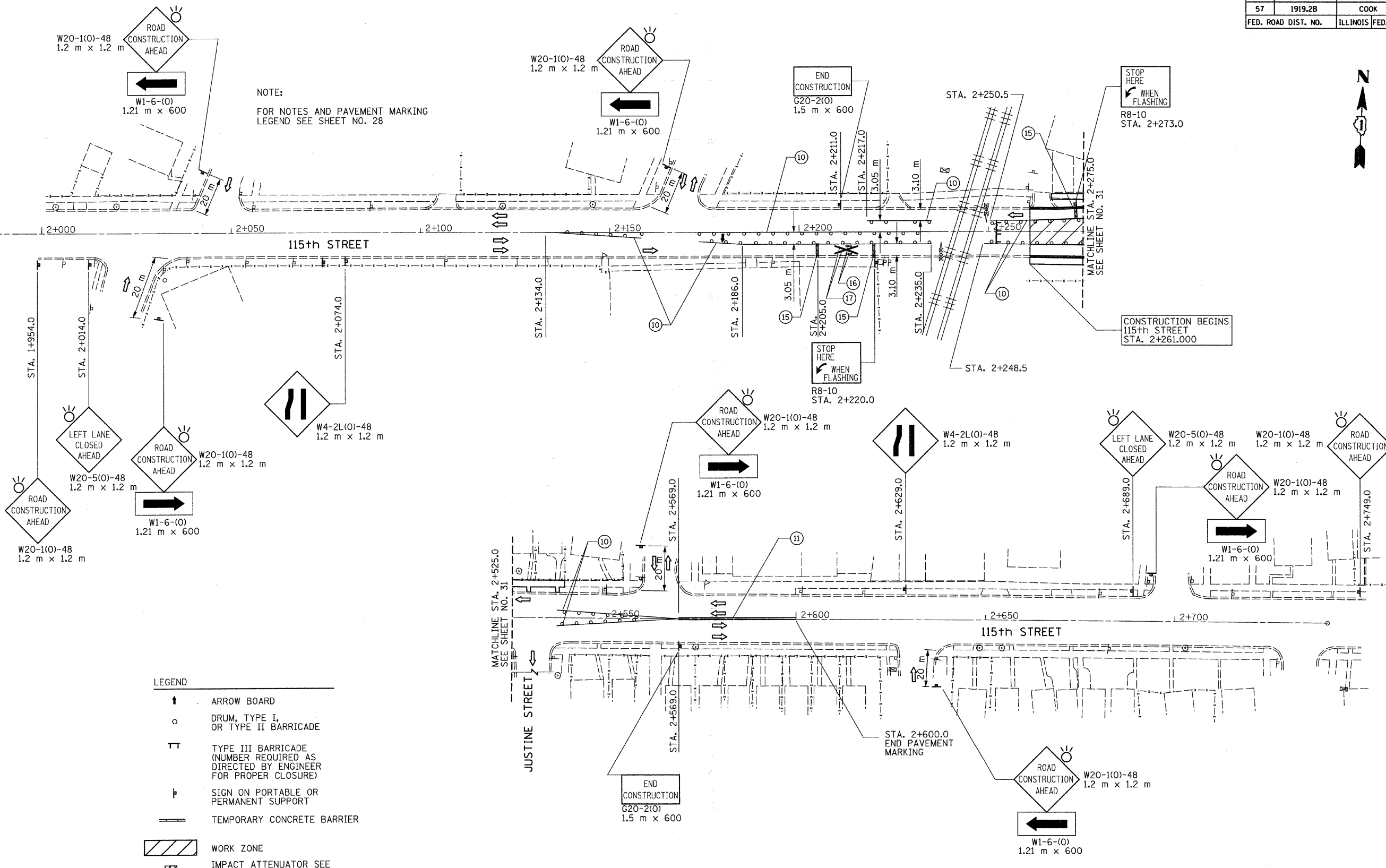

NOTE:  
FOR NOTES AND PAVEMENT MARKING  
LEGEND SEE SHEET NO. 28

**LEGEND**

	ARROW BOARD
	DRUM, TYPE I, OR TYPE II BARRICADE
	TYPE III BARRICADE (NUMBER REQUIRED AS DIRECTED BY ENGINEER FOR PROPER CLOSURE)
	SIGN ON PORTABLE OR PERMANENT SUPPORT
	TEMPORARY CONCRETE BARRIER
	WORK ZONE
	IMPACT ATTENUATOR SEE STANDARD 701321



REVISIONS	
NAME	DATE

ILLINOIS DEPARTMENT OF TRANSPORTATION  
SUGGESTED STAGES OF CONSTRUCTION  
AND TRAFFIC CONTROL  
STAGE III  
115th STREET

DATE: JANUARY 16, 2009

DRAWN BY: PRH  
CHECKED BY: JMH

**COLLINS ENGINEERS**  
123 North Wacker Drive  
Suite 300  
Chicago, IL 60606  
(312) 704-9300  
www.collinsengr.com  
ILLINOIS PROFESSIONAL DESIGN FIRM LICENSE NO. 184-000993

FILE: g:\2904\civil\exhibit\2904026.dgn  
DATE: 13-Jan-09 14:24



F.A.I.	SECTION	COUNTY	TOTAL SHEETS	SHEET NO.
57	1919.2B	COOK	119	33
FED. ROAD DIST. NO.		ILLINOIS	FED. AID PROJECT	

CONTRACT 60371

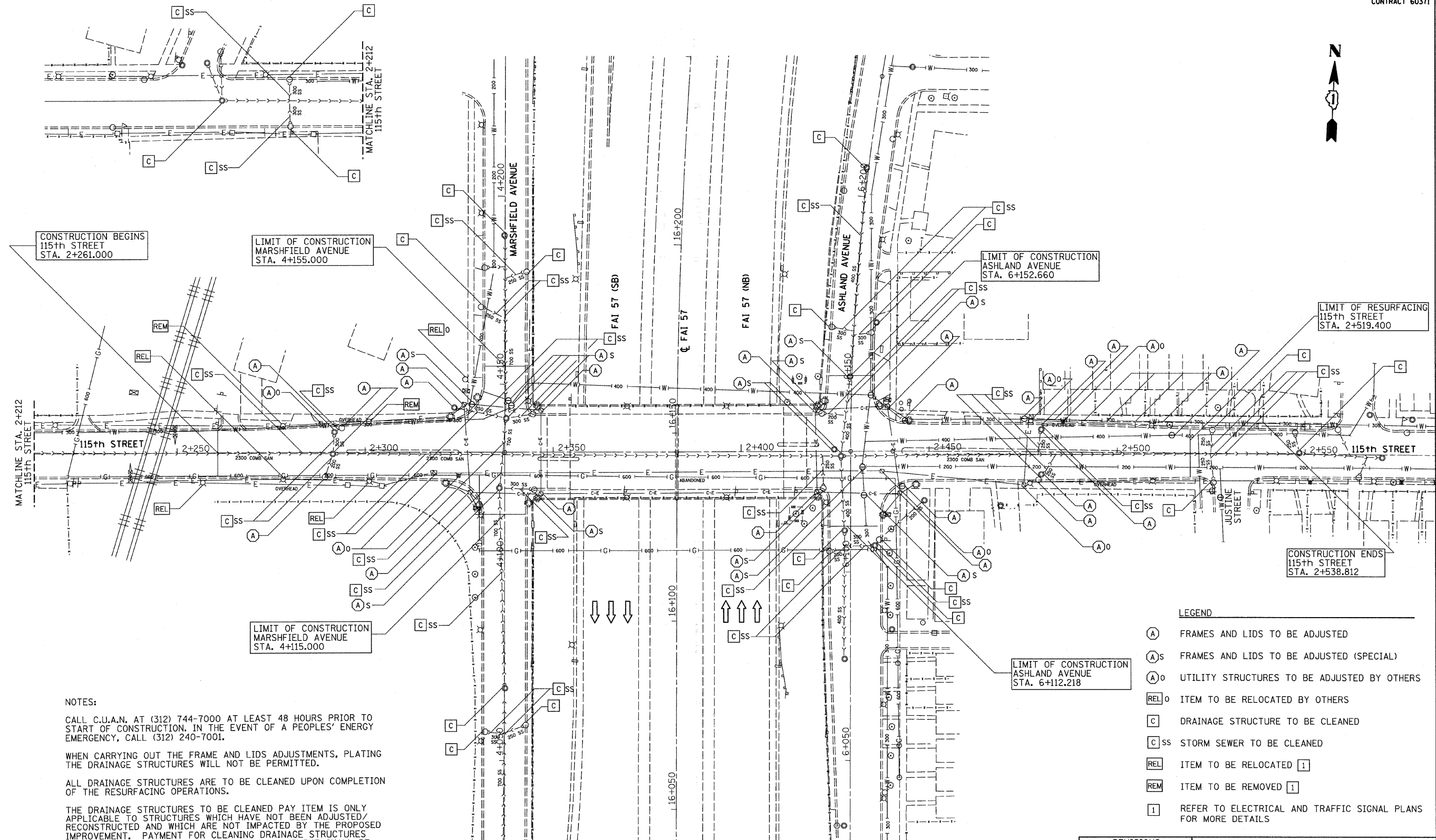

CONSTRUCTION BEGINS  
115th STREET  
STA. 2+261.000

LIMIT OF CONSTRUCTION  
MARSHFIELD AVENUE  
STA. 4+155.000

LIMIT OF CONSTRUCTION  
ASHLAND AVENUE  
STA. 6+152.660

LIMIT OF RESURFACING  
115th STREET  
STA. 2+519.400

LIMIT OF CONSTRUCTION  
MARSHFIELD AVENUE  
STA. 4+115.000

LIMIT OF CONSTRUCTION  
ASHLAND AVENUE  
STA. 6+112.218

CONSTRUCTION ENDS  
115th STREET  
STA. 2+538.812

**NOTES:**

CALL C.U.A.N. AT (312) 744-7000 AT LEAST 48 HOURS PRIOR TO START OF CONSTRUCTION. IN THE EVENT OF A PEOPLES' ENERGY EMERGENCY, CALL (312) 240-7001.

WHEN CARRYING OUT THE FRAME AND LIDS ADJUSTMENTS, PLATING THE DRAINAGE STRUCTURES WILL NOT BE PERMITTED.

ALL DRAINAGE STRUCTURES ARE TO BE CLEANED UPON COMPLETION OF THE RESURFACING OPERATIONS.

THE DRAINAGE STRUCTURES TO BE CLEANED PAY ITEM IS ONLY APPLICABLE TO STRUCTURES WHICH HAVE NOT BEEN ADJUSTED/RECONSTRUCTED AND WHICH ARE NOT IMPACTED BY THE PROPOSED IMPROVEMENT. PAYMENT FOR CLEANING DRAINAGE STRUCTURES THAT ARE IMPACTED BY THE PROPOSED IMPROVEMENT SHALL BE INCLUDED IN THE PAY ITEM FOR STRUCTURE ADJUSTMENT.

FOR FIRE HYDRANTS TO BE RELOCATED BY THE CITY OF CHICAGO, THE CONTRACTOR AND RESIDENT ENGINEER SHALL CONTACT AND COORDINATE WITH THE CITY OF CHICAGO DEPARTMENT OF WATER MANAGEMENT AT (312) 742-5919.

**LEGEND**

- (A) FRAMES AND LIDS TO BE ADJUSTED
- (A)S FRAMES AND LIDS TO BE ADJUSTED (SPECIAL)
- (A)O UTILITY STRUCTURES TO BE ADJUSTED BY OTHERS
- REL O ITEM TO BE RELOCATED BY OTHERS
- C DRAINAGE STRUCTURE TO BE CLEANED
- C SS STORM SEWER TO BE CLEANED
- REL ITEM TO BE RELOCATED [1]
- REM ITEM TO BE REMOVED [1]
- [1] REFER TO ELECTRICAL AND TRAFFIC SIGNAL PLANS FOR MORE DETAILS

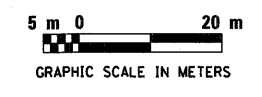

REVISIONS	
NAME	DATE

ILLINOIS DEPARTMENT OF TRANSPORTATION  
EXISTING DRAINAGE AND UTILITY PLAN  
115th STREET

DRAWN BY: PRH  
CHECKED BY: JMH

DATE: JANUARY 16, 2009

**COLLINS ENGINEERS**  
123 North Wacker Drive  
Suite 300  
Chicago, IL 60606  
(312) 704-9300  
www.collinseng.com  
ILLINOIS PROFESSIONAL DESIGN FIRM LICENSE NO. 184-000993

FILE: g:\2904\GMV\exhib1\2904032.dgn  
DATE: 13-Jan-09 14:24

F.A.I.	SECTION	COUNTY	TOTAL SHEETS	SHEET NO.
57	1919.2B	COOK	119	34
FED. ROAD DIST. NO.		ILLINOIS FED. AID PROJECT		
CONTRACT 60371				

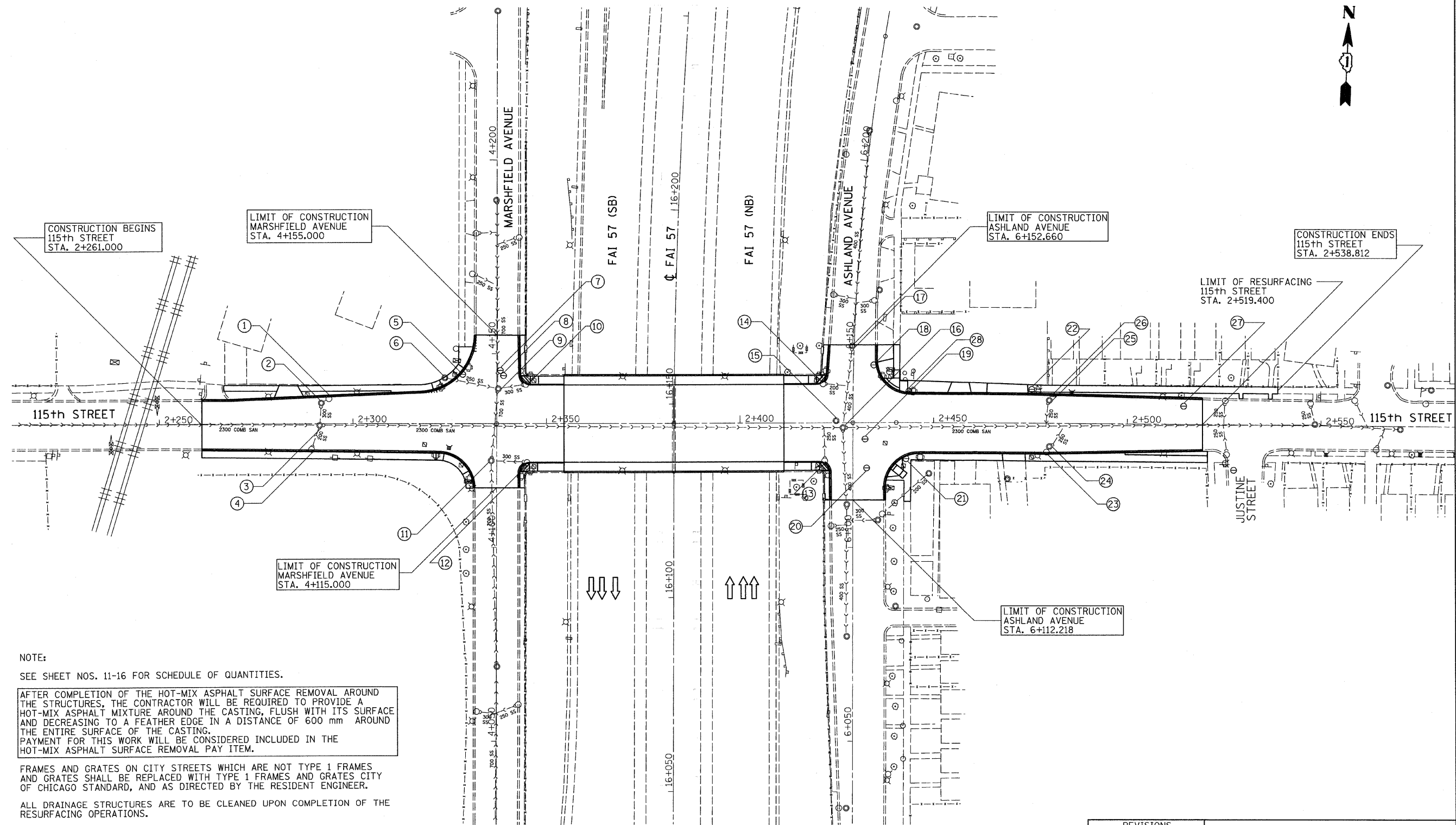

**NOTE:**

SEE SHEET NOS. 11-16 FOR SCHEDULE OF QUANTITIES.

AFTER COMPLETION OF THE HOT-MIX ASPHALT SURFACE REMOVAL AROUND THE STRUCTURES, THE CONTRACTOR WILL BE REQUIRED TO PROVIDE A HOT-MIX ASPHALT MIXTURE AROUND THE CASTING, FLUSH WITH ITS SURFACE AND DECREASING TO A FEATHER EDGE IN A DISTANCE OF 600 mm AROUND THE ENTIRE SURFACE OF THE CASTING. PAYMENT FOR THIS WORK WILL BE CONSIDERED INCLUDED IN THE HOT-MIX ASPHALT SURFACE REMOVAL PAY ITEM.

FRAMES AND GRATES ON CITY STREETS WHICH ARE NOT TYPE 1 FRAMES AND GRATES SHALL BE REPLACED WITH TYPE 1 FRAMES AND GRATES CITY OF CHICAGO STANDARD, AND AS DIRECTED BY THE RESIDENT ENGINEER.

ALL DRAINAGE STRUCTURES ARE TO BE CLEANED UPON COMPLETION OF THE RESURFACING OPERATIONS.

THE DRAINAGE STRUCTURES TO BE CLEANED PAY ITEM IS ONLY APPLICABLE TO STRUCTURES WHICH HAVE NOT BEEN ADJUSTED/RECONSTRUCTED AND WHICH ARE NOT IMPACTED BY THE PROPOSED IMPROVEMENT.

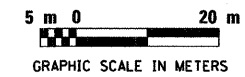

REVISIONS	
NAME	DATE

ILLINOIS DEPARTMENT OF TRANSPORTATION  
**PROPOSED DRAINAGE AND UTILITY PLAN**  
 115th STREET

**COLLINS ENGINEERS**  
 123 North Wacker Drive  
 Suite 300  
 Chicago, IL 60606  
 (312) 704-9300  
 www.collinsengr.com  
 ILLINOIS PROFESSIONAL DESIGN FIRM LICENSE NO. 184-000993

DATE: JANUARY 16, 2009  
 DRAWN BY: PRH  
 CHECKED BY: JMH

F.A.I.	SECTION	COUNTY	TOTAL SHEETS	SHEET NO.
57	1919.2B	COOK	119	35
FED. ROAD DIST. NO.		ILLINOIS	FED. AID PROJECT	

CONTRACT 60371

DRAINAGE SCHEDULE (115TH STREET AND ASHLAND AVENUE)						
STRUCTUE NUMBER	LOCATION		PROPOSED		NOTE	ACTION TAKEN
	STATION	OFFSET (METERS)	EXISTING RIM ELEVATION	RIM ELEVATION		
115TH STREET						
1	2+293.81	6.5 LT	187.17	187.199	CATCH BASIN, TYPE A	TO BE ADJUSTED
2	2+291.84	6.0 LT	187.19	187.224	MANHOLE, TYPE A	TO BE ADJUSTED
3	2+291.41	0.4 RT	187.29	187.324	MANHOLE, TYPE A	TO BE ADJUSTED
4	2+289.28	6.7 RT	187.14	187.236	CATCH BASIN, TYPE A	TO BE ADJUSTED
5	2+328.37	12.8 LT	187.14	187.440	WATER MAIN	TO BE ADJUSTED
6	2+323.76	11.9 LT	187.23	187.527	MANHOLE, TYPE A	TO BE ADJUSTED
7	2+338.09	13.8 LT	187.70	187.779	WATER MAIN	TO BE ADJUSTED
8	2+338.91	12.4 LT	187.76	187.839	WATER MAIN	TO BE ADJUSTED
9	2+337.55	9.0 LT	187.78	187.853	MANHOLE, TYPE A	TO BE ADJUSTED
10	2+344.66	10.1 LT	187.98	188.114	CATCH BASIN, TYPE A	TO BE ADJUSTED
11	2+335.68	9.6 RT	187.64	187.764	MANHOLE, TYPE A	TO BE ADJUSTED
12	2+344.94	10.1 RT	188.03	188.125	CATCH BASIN, TYPE A	TO BE ADJUSTED
13	2+421.85	0.5 LT	187.70	187.785	CATCH BASIN, TYPE A	TO BE ADJUSTED
14	2+421.46	1.3 RT	187.73	187.795	CATCH BASIN, TYPE A	TO BE ADJUSTED
15	2+424.82	4.2 RT	187.76	187.858	MANHOLE, TYPE A	TO BE ADJUSTED
16	2+426.59	11.7 RT	187.70	187.858	MANHOLE, TYPE A	TO BE ADJUSTED
19	2+432.29	4.2 RT	187.51	187.597	WATER MAIN	TO BE ADJUSTED
20	2+432.67	11.7 RT	187.42	187.441	WATER MAIN	TO BE ADJUSTED
21	2+442.84	9.4 RT	187.48	187.458	WATER MAIN	TO BE ADJUSTED
22	2+475.36	8.5 LT	187.20	187.213	WATER MAIN	TO BE ADJUSTED
23	2+479.08	7.8 RT	186.91	186.908	CATCH BASIN, TYPE A	TO BE ADJUSTED
24	2+479.09	6.3 RT	186.99	186.948	MANHOLE, TYPE A	TO BE ADJUSTED
25	2+479.86	5.6 LT	186.97	187.113	MANHOLE, TYPE A	TO BE ADJUSTED
26	2+480.77	6.9 LT	186.90	187.087	INLET, TYPE A	TO BE ADJUSTED
27	2+514.54	4.1 LT	187.05	187.051	WATER MAIN	TO BE ADJUSTED
28	2+443.57	8.9 LT	187.34	187.460	WATER MAIN	TO BE ADJUSTED
ASHLAND AVENUE						
17	6+152.08	0.2 LT	187.39	187.386	MANHOLE, TYPE A	TO BE ADJUSTED
18	6+147.17	5.4 RT	187.36	187.358	WATER MAIN	TO BE ADJUSTED

FILE:ep\2904\civil\exhibit\2904034.dgn  
DATE: 02-16-09 14:24

**COLLINS ENGINEERS**  
123 North Wacker Drive  
Suite 300  
Chicago, IL 60606  
(312) 704-9300  
www.collinsengr.com  
ILLINOIS PROFESSIONAL DESIGN FIRM LICENSE NO. 184-000993

REVISIONS	
NAME	DATE

ILLINOIS DEPARTMENT OF TRANSPORTATION  
  
DRAINAGE SCHEDULE  
115th STREET  
  
DRAWN BY: PRH  
CHECKED BY: JMH  
DATE: JANUARY 16, 2009

F.A.I.	SECTION	COUNTY	TOTAL SHEETS	SHEET NO.
57	1919.2B	COOK	119	36
FED. ROAD DIST. NO.		ILLINOIS FED. AID PROJECT	CONTRACT 60371	



FAI 57

16+100

16+150

MATCHLINE STA. 2+390.000  
SEE SHEET NO. 37

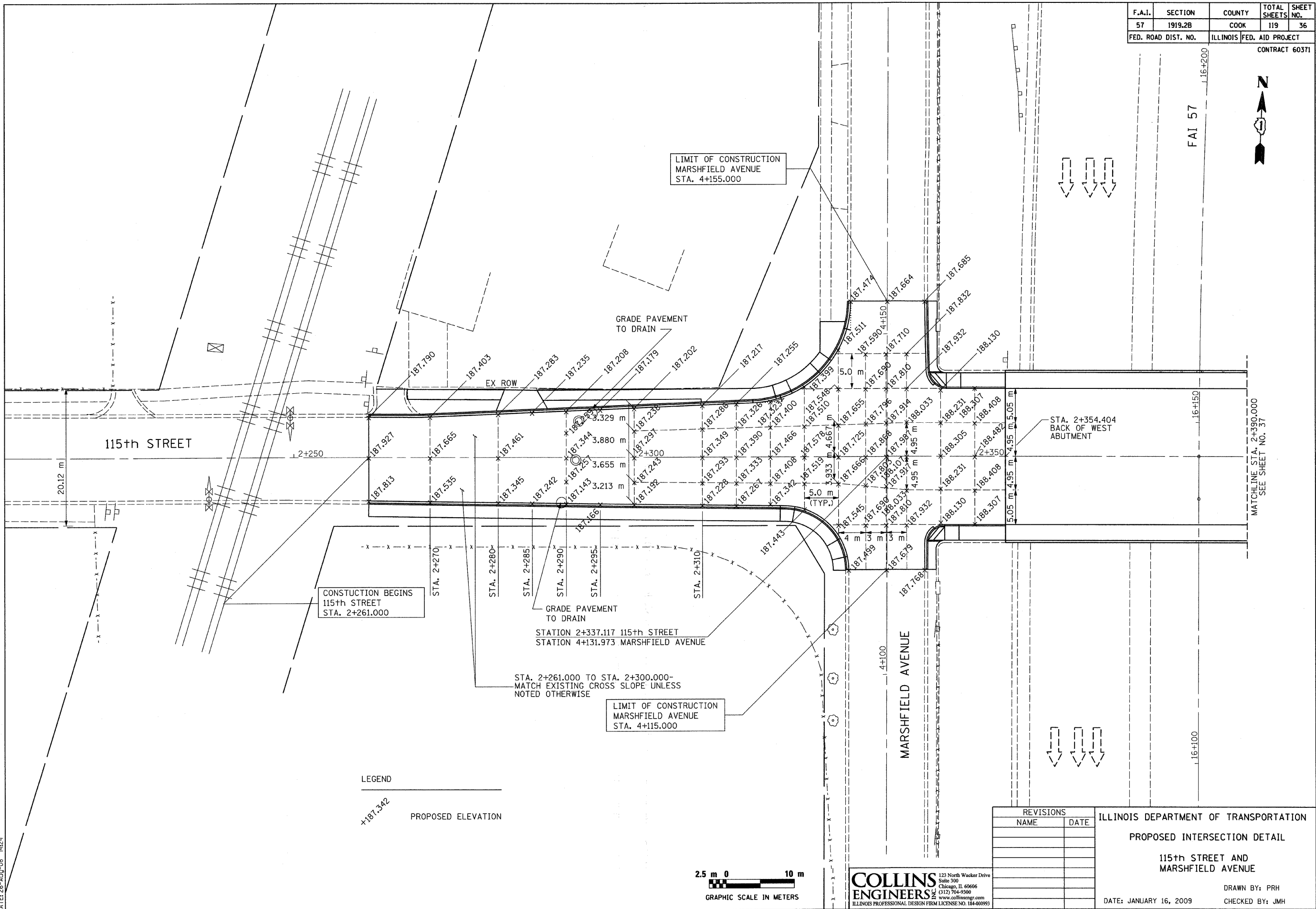

CONSTRUCTION BEGINS  
115th STREET  
STA. 2+261.000

LIMIT OF CONSTRUCTION  
MARSHFIELD AVENUE  
STA. 4+155.000

LIMIT OF CONSTRUCTION  
MARSHFIELD AVENUE  
STA. 4+115.000

LEGEND  
+187.342 PROPOSED ELEVATION

STA. 2+261.000 TO STA. 2+300.000-  
MATCH EXISTING CROSS SLOPE UNLESS  
NOTED OTHERWISE

GRADE PAVEMENT  
TO DRAIN  
STATION 2+337.117 115th STREET  
STATION 4+131.973 MARSHFIELD AVENUE

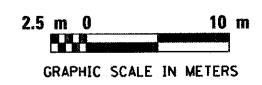

REVISIONS	
NAME	DATE

ILLINOIS DEPARTMENT OF TRANSPORTATION  
PROPOSED INTERSECTION DETAIL  
115th STREET AND  
MARSHFIELD AVENUE  
DRAWN BY: PRH  
CHECKED BY: JMH  
DATE: JANUARY 16, 2009

**COLLINS ENGINEERS**  
123 North Wacker Drive  
Suite 300  
Chicago, IL 60606  
(312) 704-9300  
www.collinsengr.com  
ILLINOIS PROFESSIONAL DESIGN FIRM LICENSE NO. 184-000993

FILE: g:\2304\civil\exhibit\2304035.dgn  
DATE: 26-AUG-08 14:24

F.A.I.	SECTION	COUNTY	TOTAL SHEETS	SHEET NO.
57	1919.2B	COOK	119	37
FED. ROAD DIST. NO.		ILLINOIS FED. AID PROJECT		

CONTRACT 60371

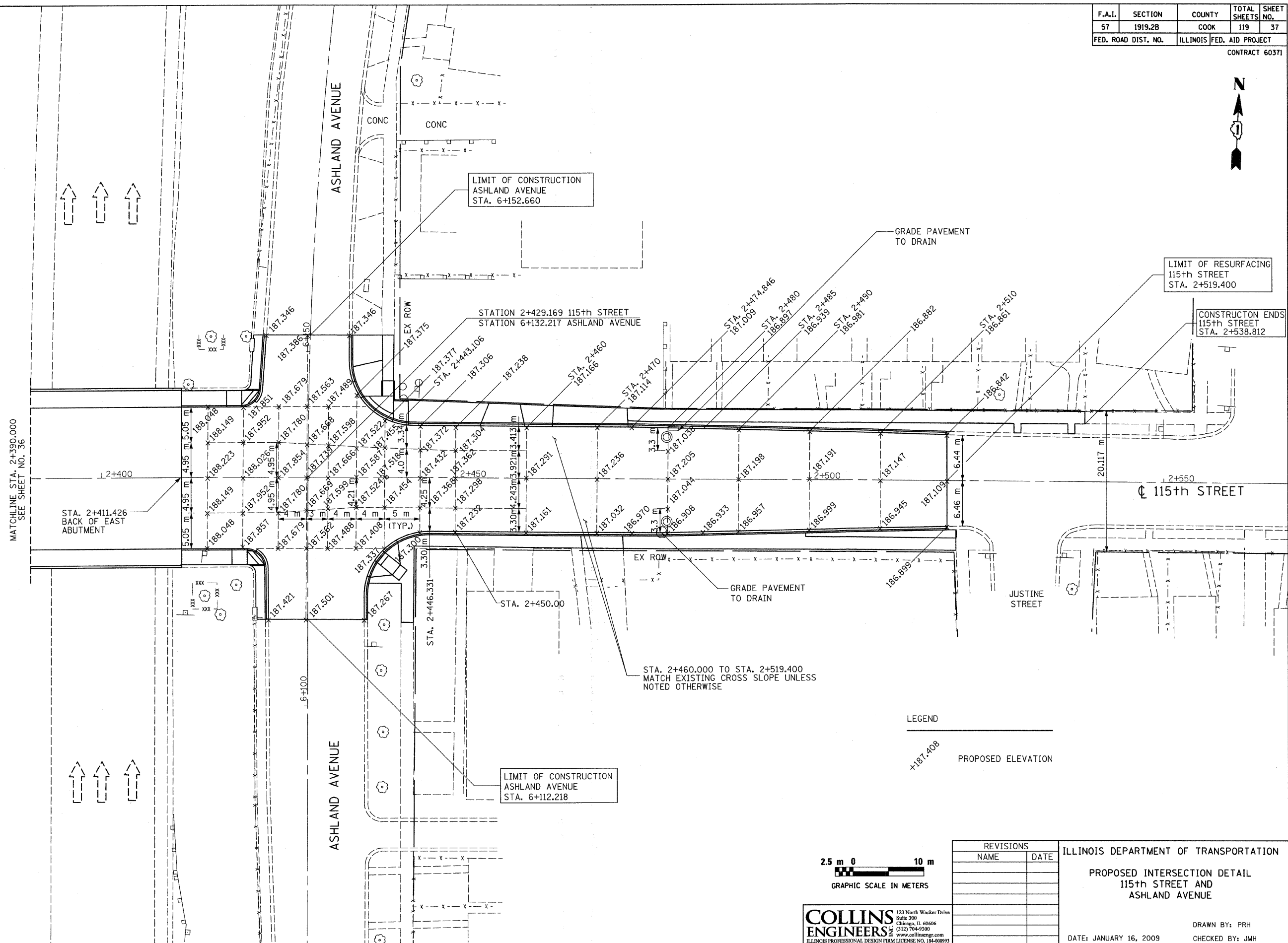

MATCHLINE STA. 2+390.000  
SEE SHEET NO. 36

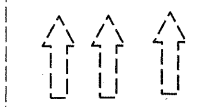

LEGEND  
- - - - - x - - - - -  
PROPOSED ELEVATION

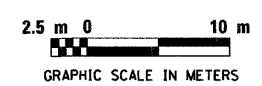

**COLLINS ENGINEERS**  
123 North Wacker Drive  
Suite 300  
Chicago, IL 60606  
(312) 794-9300  
www.collinseng.com  
ILLINOIS PROFESSIONAL DESIGN FIRM LICENSE NO. 184-000993

REVISIONS	
NAME	DATE

ILLINOIS DEPARTMENT OF TRANSPORTATION  
**PROPOSED INTERSECTION DETAIL  
115th STREET AND  
ASHLAND AVENUE**  
DRAWN BY: PRH  
CHECKED BY: JMH  
DATE: JANUARY 16, 2009

FILE: 2904\civil\exhib\2904036.dgn  
DATE: 26-Aug-08 14:24

F.A.I.	SECTION	COUNTY	TOTAL SHEETS	SHEET NO.
57	1919.2B	COOK	119	38
FED. ROAD DIST. NO.		ILLINOIS FED. AID PROJECT		
CONTRACT 60371				

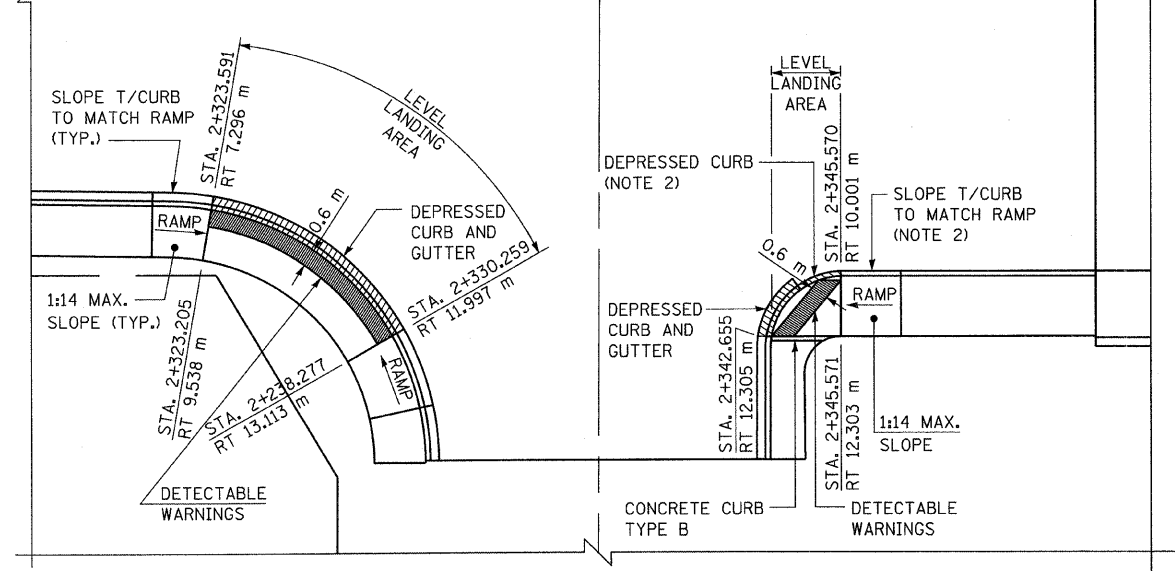
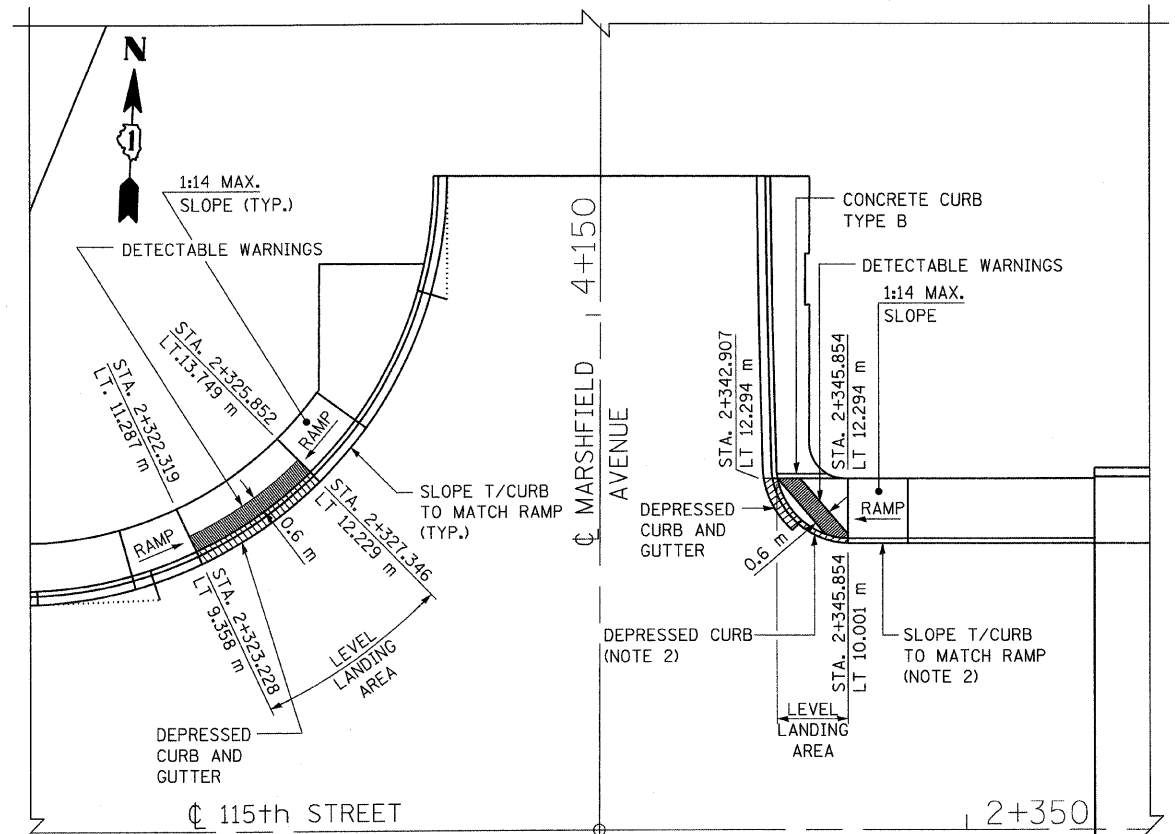

MARSHFIELD AVENUE

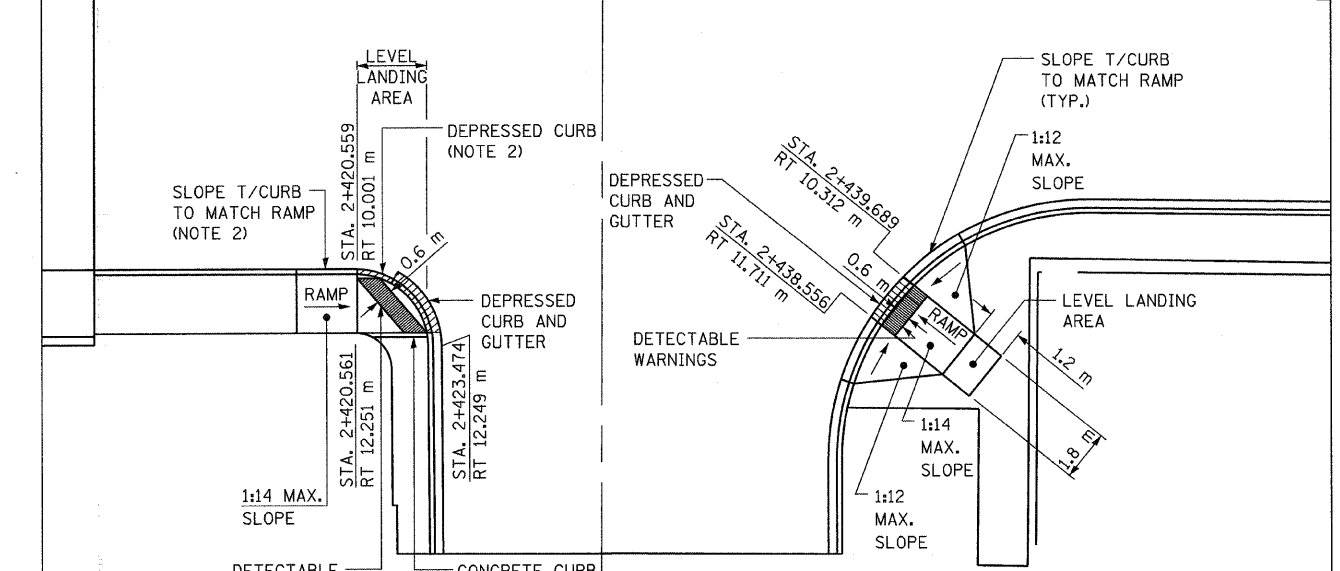
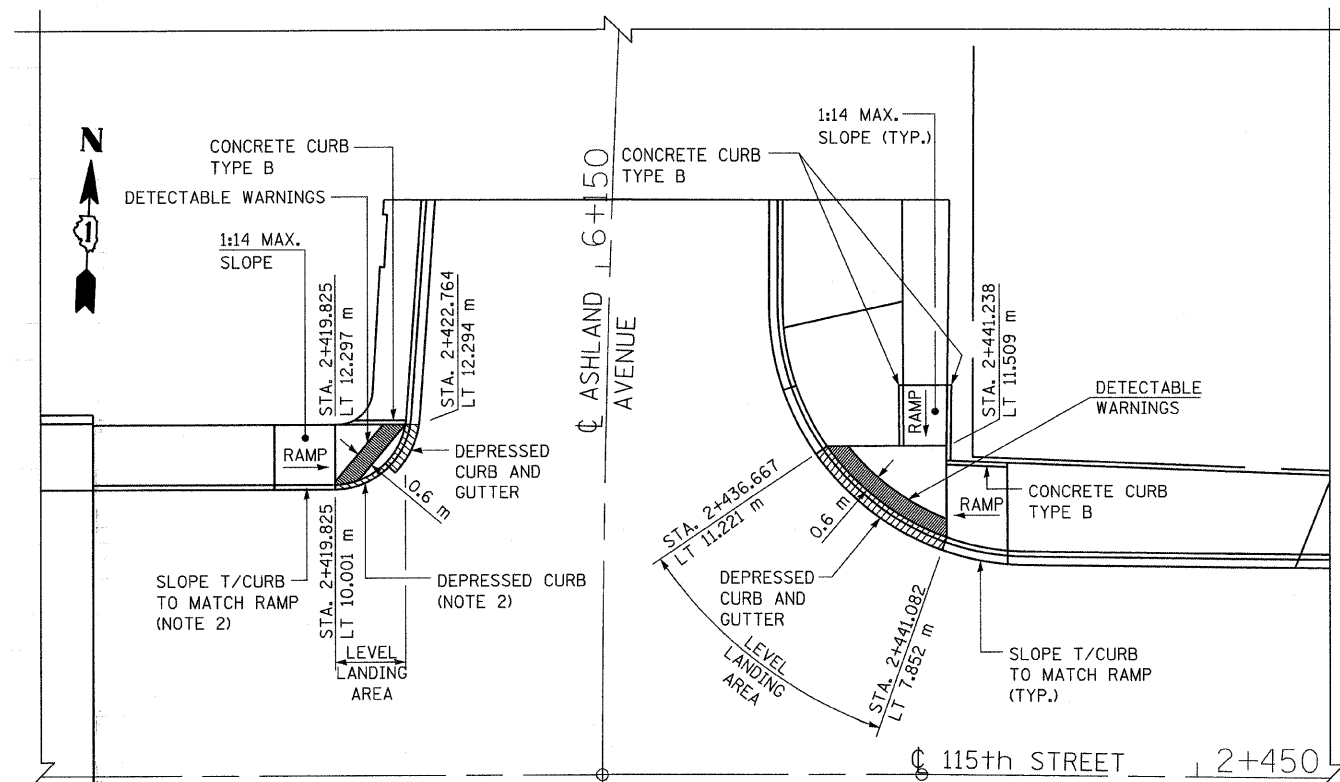

ASHLAND AVENUE

- NOTES:
1. DEPRESSURED CURB AND GUTTER SHALL BE MEASURED AND PAID FOR AS COMBINATION CONCRETE CURB AND GUTTER TYPE B15.30.
  2. WORK THESE DETAILS WITH BRIDGE APPROACH PAVEMENT DETAILS.

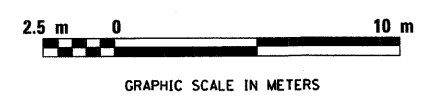

REVISIONS	
NAME	DATE

ILLINOIS DEPARTMENT OF TRANSPORTATION  
 ADA CURB RAMP DESIGN DETAILS  
 115th STREET AND  
 MARSHFIELD AVENUE AND ASHLAND AVENUE  
 DRAWN BY: PRH  
 CHECKED BY: JMH  
 DATE: JANUARY 16, 2009

**COLLINS ENGINEERS**  
 123 North Wacker Drive  
 Suite 300  
 Chicago, IL 60606  
 (312) 704-9300  
 www.collinsengr.com  
 ILLINOIS PROFESSIONAL DESIGN FIRM LICENSE NO. 184-000993

FILE: g:\2304\civil\exhibit\2304040.dgn  
 DATE: 15-JUN-09 14:24

F.A.I.	SECTION	COUNTY	TOTAL SHEETS	SHEET NO.
57	1919.2B	COOK	119	39
FED. ROAD DIST. NO.		ILLINOIS FED. AID PROJECT		

CONTRACT 60371

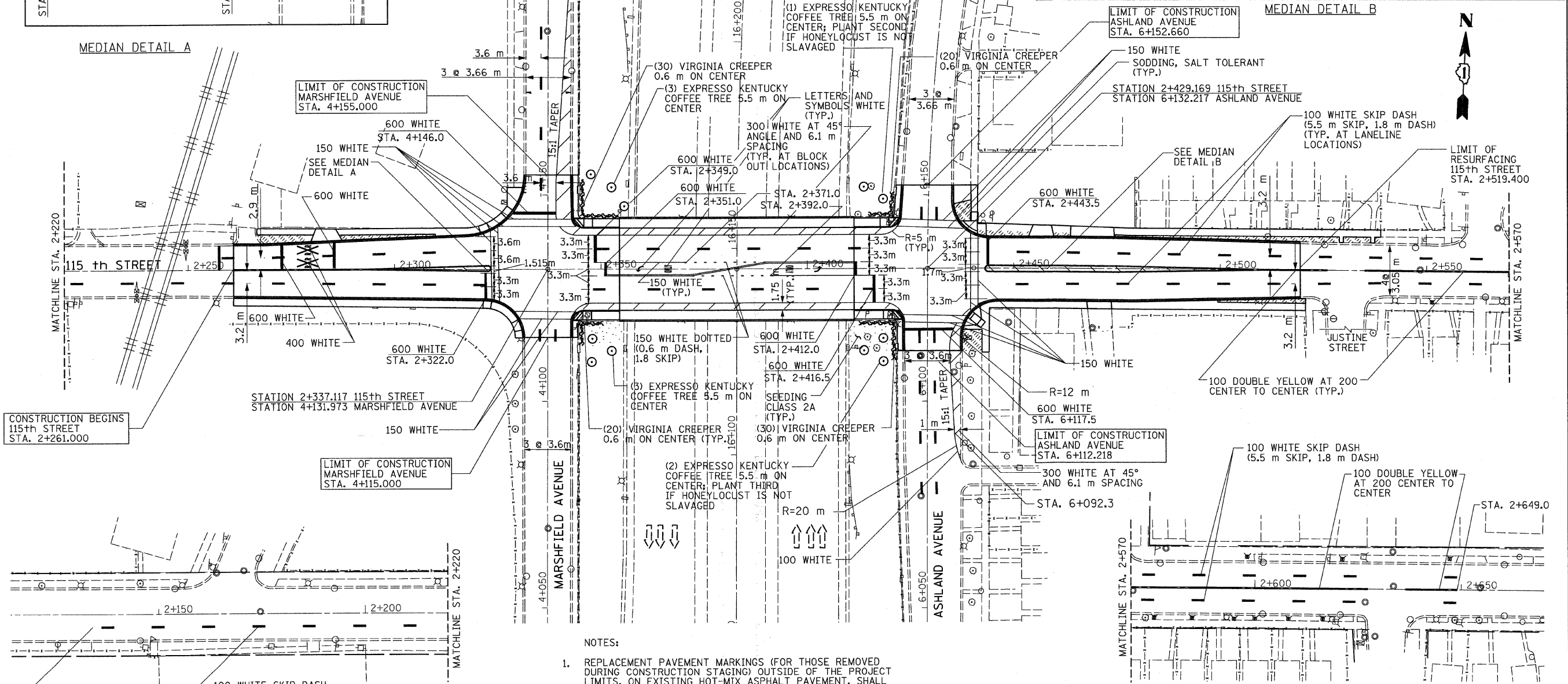
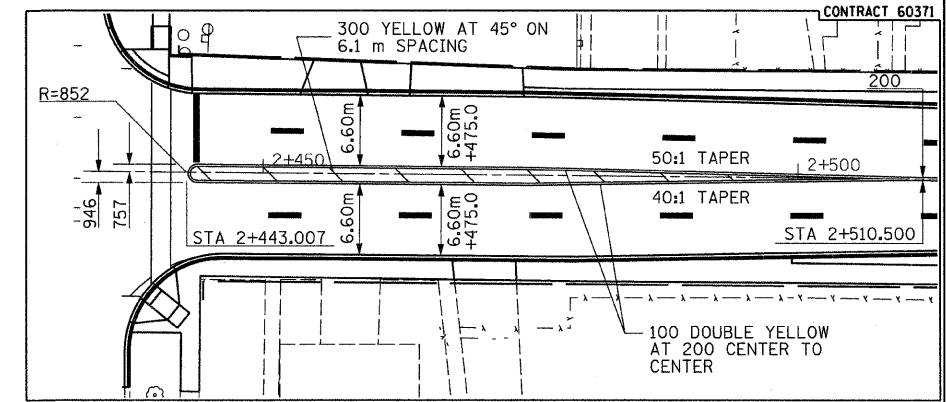
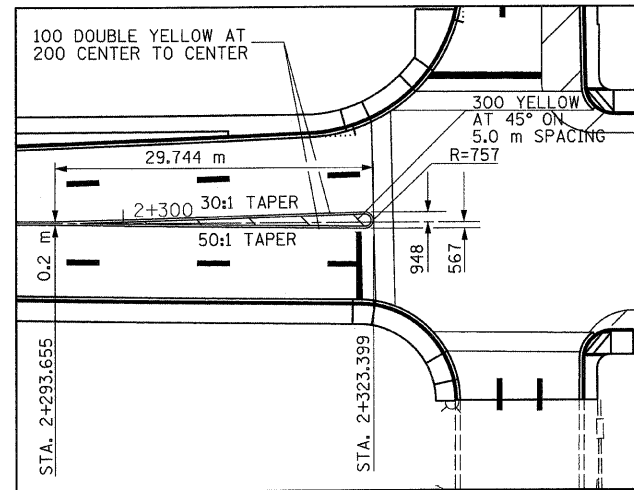

NOTES:

1. REPLACEMENT PAVEMENT MARKINGS (FOR THOSE REMOVED DURING CONSTRUCTION STAGING) OUTSIDE OF THE PROJECT LIMITS, ON EXISTING HOT-MIX ASPHALT PAVEMENT, SHALL BE THERMOPLASTIC.
2. ALL PAVEMENT MARKINGS SHALL CONFORM TO THE MANUAL ON UNIFORM TRAFFIC CONTROL DEVICES AND THE CITY OF CHICAGO TYPICAL PAVEMENT MARKINGS STANDARD, TC-24.
3. PAVEMENT MARKINGS INSTALLED ON HOT-MIX ASPHALT SURFACE SHALL BE THERMOPLASTIC. PAVEMENT MARKINGS INSTALLED ON CONCRETE SURFACES SHALL BE POLYUREA TYPE I.

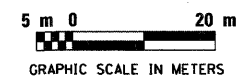

REVISIONS	
NAME	DATE

ILLINOIS DEPARTMENT OF TRANSPORTATION  
PAVEMENT MARKING AND LANDSCAPING PLAN  
115th STREET

1:500  
DATE: JANUARY 16, 2009  
DRAWN BY: PRH  
CHECKED BY: JMH

**COLLINS ENGINEERS**  
123 North Wacker Drive  
Suite 300  
Chicago, IL 60606  
(312) 704-9300  
www.collinseng.com  
ILLINOIS PROFESSIONAL DESIGN FIRM LICENSE NO. 184-000993

FILE: 2904\civil\exhibits\2904038.dgn  
DATE: 25-AUG-08 14:24

F.A.I.	SECTION	COUNTY	TOTAL SHEETS	SHEET NO.
57	1919.2B	COOK	119	40
FED. ROAD DIST. NO.		ILLINOIS FED. AID PROJECT		CONTRACT 60371

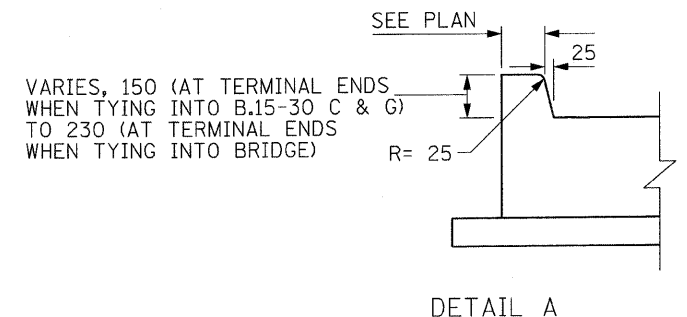
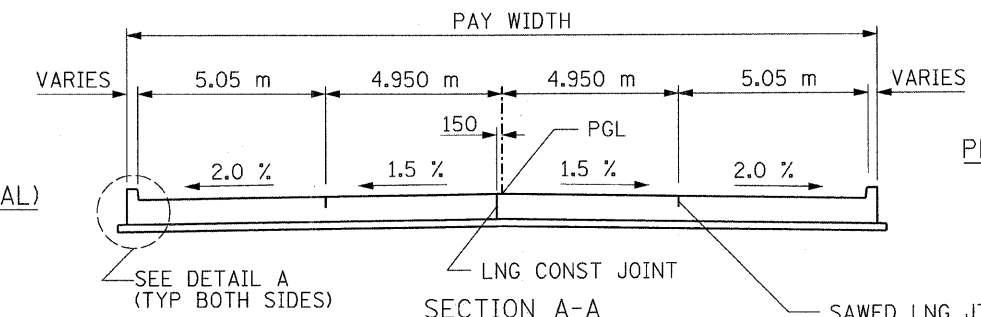
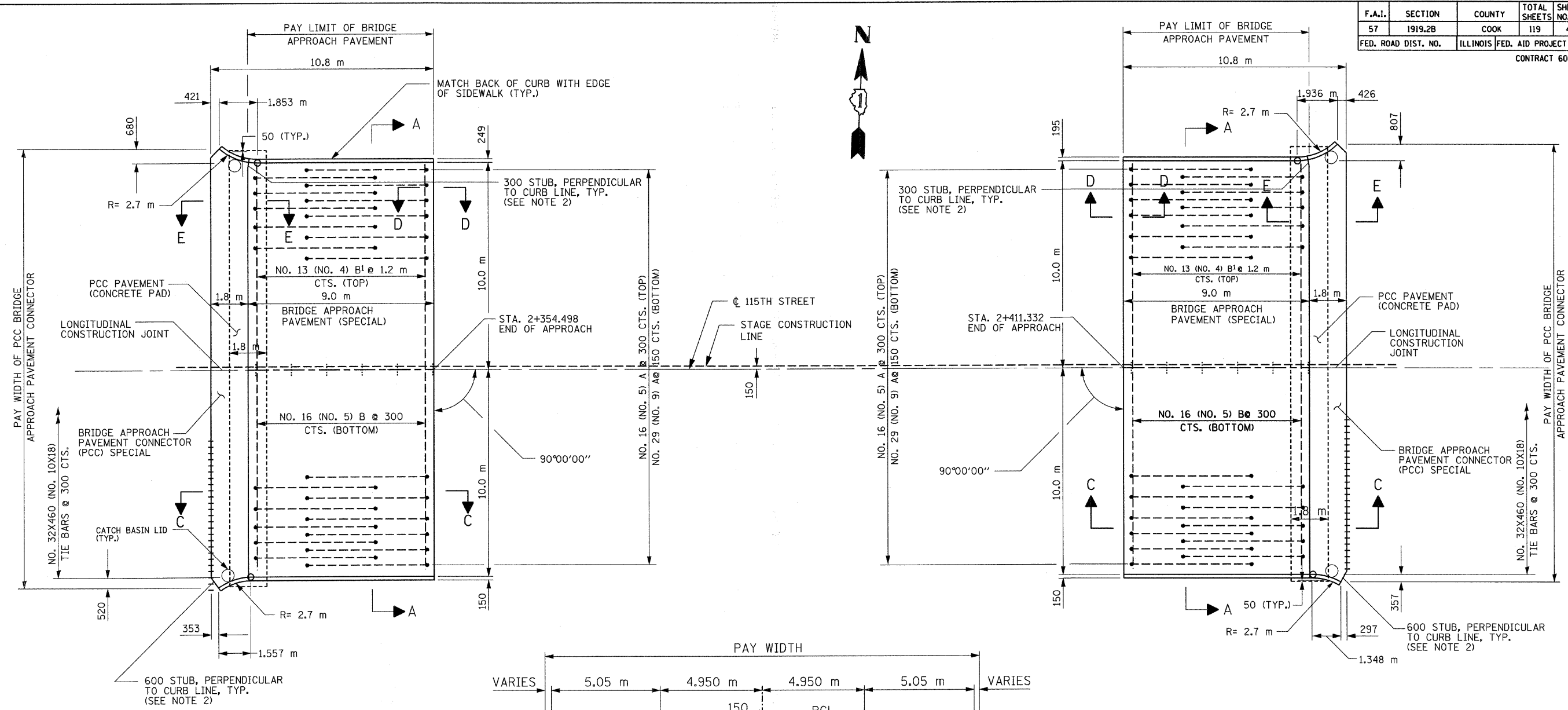

- NOTES:**
- WIDTH OF CURB AT APPROACH SLAB IS MODIFIED FROM 75 TO 200±. LENGTH OF REINFORCEMENT BARS SHALL BE ADJUSTED AS REQUIRED.
  - STUB DIMENSION DOES NOT INCLUDE WIDTH OF CURB
  - ALL DIMENSION SHALL BE VERIFIED IN THE FIELD PRIOR TO CONSTRUCTION.
  - SEE STRUCTURAL SHEET S14 AND S17 OF S23 FOR SIDEWALK DETAILS.
  - SEE SHEET 41 FOR SECTIONS C-C, D-D AND E-E.
  - REINFORCEMENT BARS, BAR SPLICERS, TIE BARS, PREFORMED JOINT SEAL, SUB-BASE, IMPROVED SUBGRADE, BOND BREAKER AND CONCRETE PAD (INCLUDING REINFORCEMENT) SHALL BE INCLUDED WITH "BRIDGE APPROACH PAVEMENT (SPECIAL)".
  - SEE STANDARD 421001 FOR REINFORCEMENT DETAILS NOT SHOWN.
  - SEE STANDARD 420001 FOR JOINT DETAILS NOT SHOWN.

**BILL OF MATERIAL**

ITEM	UNIT	TOTAL
APPROACH SLAB REMOVAL	SQ. M	234
PAVEMENT REMOVAL	SQ. M	182
BRIDGE APPROACH PAVEMENT (SPECIAL)	SQ. M	366
BRIDGE APPROACH PAVEMENT CONNECTOR (PCC SPECIAL)	SQ. M	73

REVISIONS		ILLINOIS DEPARTMENT OF TRANSPORTATION
NAME	DATE	
		<b>BRIDGE APPROACH PAVEMENT DETAILS I</b> <b>115th STREET</b> DRAWN BY: PRH CHECKED BY: JMH DATE: JANUARY 16, 2009

**COLLINS ENGINEERS**  
 123 North Wacker Drive  
 Suite 300  
 Chicago, IL 60606  
 (312) 704-9300  
 www.collinsengr.com  
 ILLINOIS PROFESSIONAL DESIGN FIRM LICENSE NO. 184-000993

FILE: 042904\civil\exhibit\2904037.dgn  
 DATE: 27-Aug-08 14:24



F.A.I.	SECTION	COUNTY	TOTAL SHEETS	SHEET NO.
57	1919.2B	COOK	119	41
FED. ROAD DIST. NO.		ILLINOIS FED. AID PROJECT		CONTRACT 60371

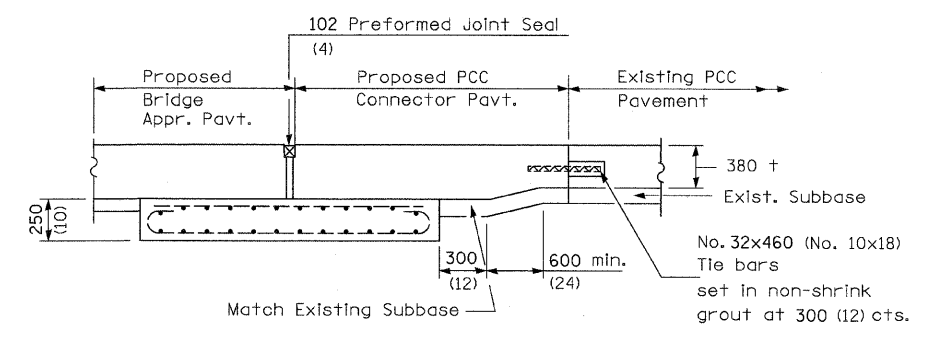
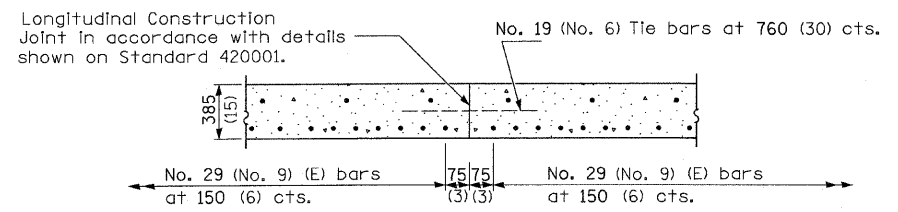
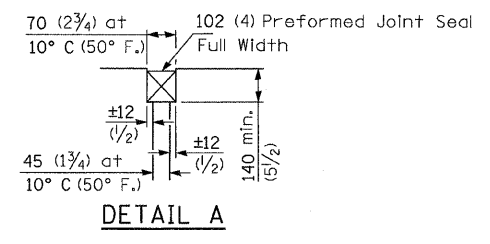
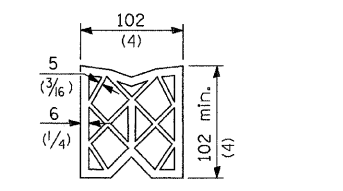
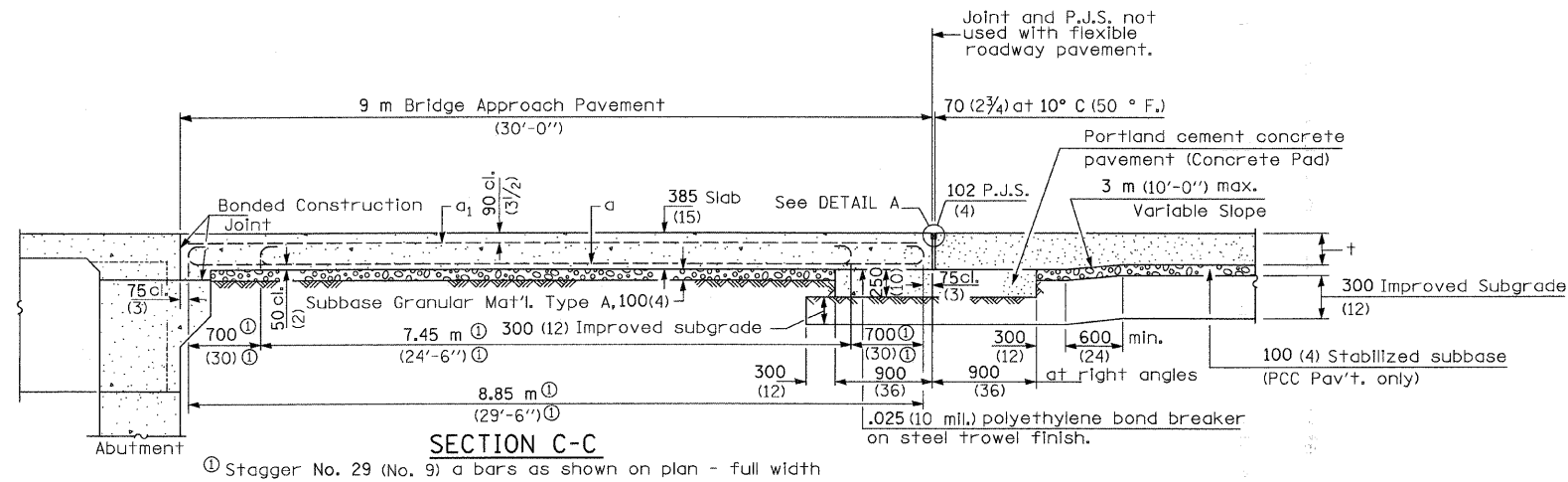

**STAGE CONSTRUCTION JOINT AND OPTIONAL LONGITUDINAL CONSTRUCTION JOINT**

As approved by the Engineer, the Contractor may elect to reduce the widths of pour by use of the Optional Longitudinal Construction Joint shown. Joints shall be located at the edge of a traffic lane.

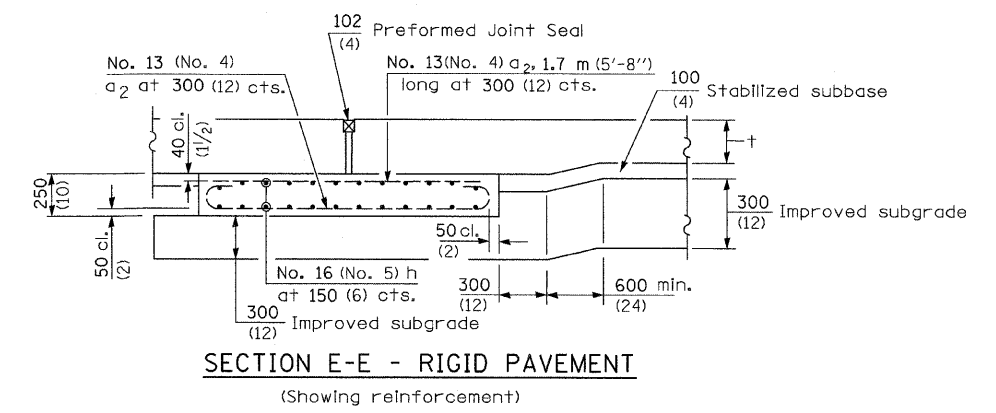
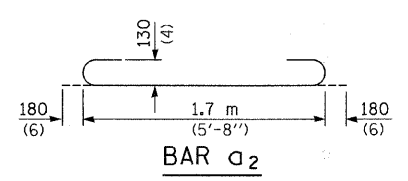
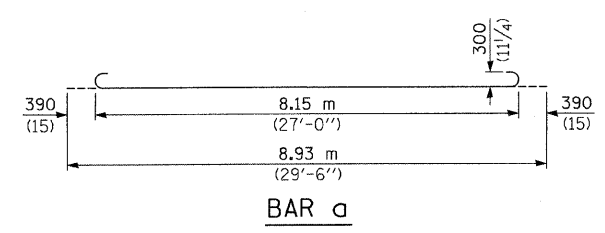

**DESIGN STRESSES**  
 fy = 400 MPa (60,000 p.s.i.)  
 fc = 24 MPa (3,500 p.s.i.)

**NOTES:**  
 See standard 420001 for joint details not shown.  
 All dimensions are in millimeters (Inches) unless otherwise noted.

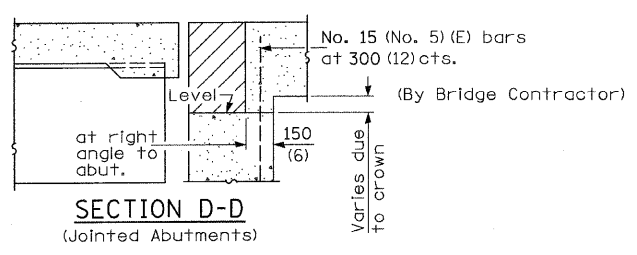

REVISIONS		ILLINOIS DEPARTMENT OF TRANSPORTATION
NAME	DATE	
		BRIDGE APPROACH PAVEMENT DETAILS II 115th STREET DRAWN BY: PRRH CHECKED BY: JMH

**COLLINS ENGINEERS**  
 123 North Wacker Drive  
 Suite 300  
 Chicago, IL 60606  
 (312) 704-9300  
 www.collinseng.com  
 ILLINOIS PROFESSIONAL DESIGN FIRM LICENSE NO. 184-000993

FILE: g:\2904\civil\exhibit\2904039.dgn  
 DATE: 28-Aug-08 14:24

F.A.I. RTE.	SECTION	COUNTY	TOTAL SHEETS	SHEET NO.
57	1919.2B	COOK	119	42
STA.		TO STA.		
FED. ROAD DIST. NO.		ILLINOIS FED. AID PROJECT		

CONTRACT #60371

PROPOSED	PRESENT	DESCRIPTION
		SIGNAL, TRAFFIC 3 SECTION 1-WAY ADJUSTABLE, 12" OR AS NOTED
		SIGNAL, TRAFFIC 3 SECTION 2-WAY ADJUSTABLE, 12" OR AS NOTED
		SIGNAL OPTICALLY PROGRAMMED
		SIGNAL, PEDESTRIAN, DON'T WALK/WALK
		SIGNAL FACE ARROW, 12" COLOR AS NOTED
		SIGNAL FACE, 1 SECTION YELLOW/GREEN ARROW DUAL INDICATION
		PUSH BUTTON, PEDESTRIAN
		SIGN, ILLUMINATED, WITH MESSAGE OR SYMBOL AS INDICATED
		MAST ARM, MONOTUBE, STEEL, SIZE AS INDICATED (SEE DWG. #870)
		MAST ARM, TRUSS, ALUMINUM, SIZE AS INDICATED
		CONTROLLER, TRAFFIC SIGNAL, PEDESTAL OR BASE MOUNTED AS INDICATED
		CONTROLLER, STREET LIGHTING, PEDESTAL OR BASE MOUNTED. (DWG. 876 OR 880)
		CONTROLLER, STREET LIGHTING, POLE MOUNTED (DWG. #11940)
		POLE, WOOD, COMMONWEALTH EDISON COMPANY SERVICE
		POLE, CITY STEEL, ANCHOR BASE, 34'-6", 7 GA., 10" DIA. AND 15" B.C. 24'x7' FND. W/1 1/4" ANCHOR RODS DRG. #818.
		POLE, CITY STEEL, ANCHOR BASE, 34'-6", 3 GA., 10" DIA. AND 15" B.C. 24'x9' FND. W/1 1/4" ANCHOR RODS DRG. #818 (16', 20' OR 26' M.A.)
		POLE, CITY STEEL, ANCHOR BASE, 34'-6", 3 GA., 11" DIA. AND 17 1/2" B.C. 30'x9' FND. W/1 1/4" ANCHOR RODS DRG. #816. (30' M.A.)
		POLE, CITY STEEL, ANCHOR BASE, 34'-6", 3 GA., 12 1/2" DIA. AND 16 1/2" B.C. 30'x11' FND. W/1 1/2" ANCHOR RODS DRG. #817. (35', 40' OR 44' M.A.)
		POLE, CITY STEEL, ANCHOR BASE, 32'-6", 3 GA., 10" DIA., WITH 3 GA. BAL. HSG. BASE AND 17 1/4" B.C. ON 30'x9' FND. W/ 11/4" ANCHOR RODS DRG. #816.
		POLE, CITY STEEL, ANCHOR BASE, 20', 27'-6", 29'-6", 7 GA., WITH STEEL BAL. HSG. BASE AND FND. W/10" D. B.C. AND 1" ANCHOR RODS DRG. #716.
		POLE, CITY STEEL, ANCHOR BASE, 20', 27'-6", 29'-6", 3 GA., WITH STEEL BAL. HSG. BASE AND FND. W/10" D. B.C. AND 1" ANCHOR RODS DRG. #719.
		POLE, CITY STEEL, ANCHOR BASE, 20', 27'-6", 29'-6" 7 GA., AND FND. WITH 10" B.C. AND 1" ANCHOR RODS DRG. #11408B.
		POLE, CITY STEEL, ANCHOR BASE, 20', 27'-6", 29'-6" 3 GA., AND FND. WITH 10" B.C. AND 1" ANCHOR RODS DRG. #11408B.
		POLE, CITY STEEL, ANCHOR BASE, 32'-6", 7 GA., AND FND. WITH 11 1/2" B.C. AND 1" ANCHOR RODS DRG. #753.
		POLE, CITY STEEL, ANCHOR BASE, 32'-6", 3 GA., AND FND. WITH 11 1/2" B.C. AND 1" ANCHOR RODS DRG. #753.
		POLE, CITY STEEL, ANCHOR BASE, 32'-6", 7 GA., ALUM. BHB AND FND. WITH 15" B.C.-24'x7' WITH 1" ANCHOR RODS DRG. #691.
		POLE, CITY STEEL, ANCHOR BASE, 32'-6", 3 GA., ALUM. BHB AND FND. WITH 15" B.C. 24'x7' WITH 1" ANCHOR RODS DRG. #691.
		POLE, CITY ALUMINUM, WITH ROUND BAL. HSG. BASE, 25', 28', OR 30' ON FND. WITH 14" B.C., ACQUIRED FROM CHICAGO PARK DISTRICT.
		POLE, CITY STEEL, EMBEDDED, 4"x 9"x 35' 7 GA., TAPERED TUBULAR. (DWG. #658)
		POLE, CITY STEEL, EMBEDDED, 4"x 9"x 35' 3 GA., TAPERED TUBULAR. (DWG. #658)
		POLE, CITY STEEL, EMBEDDED. (ACQUIRED FROM CTA)
		COLUMN, ELEVATED STRUCTURE
		POLE, WOOD. (SIZE AS NOTED)
		POLE, FOUNDATION WITH ELBOWS AS INDICATED. (SIZE AS NOTED)
		POLE, ORNAMENTAL OR OTHER, AS INDICATED ON THE PLANS

PROPOSED	PRESENT	DESCRIPTION
		HANDHOLE, HEAVY DUTY, 36" I.D. (DWG. #866)
		HANDHOLE, CIRCULAR WITH 24" FRAME & COVER, 30" I.D. (#867)
		MANHOLE, CITY 3'x4'x4' DWG. #729 OR 730; 4'x6'x6' DWG. #732 OR 733.
		FOUNDATION, CONTROLLER OR PEDESTAL, 13" B.C., 20"x5' (DWG. #709)
		FOUNDATION, TRAFFIC CONTROLLER DWG. #854. F.A. TERMINAL FND. DWG. #11972
		FOUNDATION, TRAFFIC TYPE "P", BASE MOUNT. (DWG. #888)
		FOUNDATION, CONTROLLER STREET LIGHT, SPECIAL, 100A & 200A. (DWG. #876 & #880)
		FOUNDATION, TRANSCLOSURE; TRANSCLOSURE HOUSING. (DWG. #583 & #891)
		CONTROLLER, UNDERPASS LIGHTING 120V. & 240V. (DWG. #860 & #861)
		MANHOLE, UTILITY, E=COMMONWEALTH EDISON; T=ILL. BELL TEL.; G=PEOPLES GAS; W=CITY WATER; P=CHGO PARK DISTRICT; CTA=C.T.A.; S=SEWER
		JUNCTION BOX, IN PAVEMENT (DWG. #815)
		DETECTOR LOOP IN PAVEMENT
		CONDUIT OR P.V.C., NUMBER, SIZE & TYPE. (AS NOTED)
		CONDUIT OR P.V.C. ENCASED IN CONCRETE. (SECTION OR NUMBER OF CONDUIT INDICATED)
		LUMINAIRE, H.P.S.V. 400W LAMP, 240V, SEMI-CUTOFF
		LUMINAIRE, H.P.S.V. 400W LAMP, 240V, CUTOFF
		LUMINAIRE, H.P.S.V. 310W LAMP, 240V
		LUMINAIRE, H.P.S.V. 310W LAMP, 240V, CUTOFF
		LUMINAIRE, H.P.S.V. 150W LAMP, 240V
		LUMINAIRE, H.P.S.V. 150W LAMP, 120V
		LUMINAIRE, H.P.S.V. 250W LAMP, 120V. (ALLEY LIGHT)
		LUMINAIRE, H.P.S.V. 250W LAMP, 120V
		TERMINAL, CABINET F.A. & P.C.
		FIRE ALARM BOX, MOUNTED
		FIRE ALARM BOX, POLE MOUNTED
		CABLE, TRAFFIC SIGNAL, COMMUNICATION, 1-PAIR #14 SHIELDED, IN CONDUIT
		CABLE, TRAFFIC SIGNAL POWER SUPPLY, 2/C-#4, 600 V. EPR. IN CONDUIT
		CABLE, TRAFFIC SIGNAL POWER SUPPLY, 2 1/C-#2 OR #1/0 600V. EPR IN CONDUIT
		CABLE, TRAFFIC SIGNAL POWER SUPPLY, 2/C-#10 OR #6, 600V NSRI, IN CONDUIT
		CABLE, TRAFFIC SIGNAL, 7/C-#12 OR #14, 600V, EPR IN CONDUIT
		CABLE, TRAFFIC SIGNAL, 10/C-#12 600V. EPR IN CONDUIT
		CABLE, TRAFFIC SIGNAL, 14/C-#14. 600V. EPR IN CONDUIT
		CABLE, TRAFFIC SIGNAL, 19/C-#12 600V, EPR IN CONDUIT
		CABLE, STREET LIGHT, 2 1/C-#6, 600V. RINS IN PARKWAY
		CABLE, STREET LIGHT, 2 1/C-#6, 600V. RINS IN CONDUIT
		CABLE, STREET LIGHT, 2 1/C-#6 EPRN 600V. & 1 1/C-#8 GREEN, TRIPLEXED, IN CONDUIT
		CABLE, STREET LIGHT, 3 1/C-#1/0, OR #2/0, OR #4, 600V. EPR IN CONDUIT
		WIRE, STREET LIGHT, 2 1/C-#6, HDNS. AERIAL
		WIRE, STREET LIGHT, 2 1/C-#6 & 1 1/C #8, HDNS. AERIAL
		CABLE, STREET LIGHT AERIAL, 3 1/C-#4 OR #2 SELF SUPPORTING, 600V EPR
		WIRE, F.A. & P.C. AERIAL, 1/C-#10, NUMERAL DENOTES QUANTITY
		CABLE, F.A. & P.C. AERIAL, W/ MESSENGER #19-(NUMBER OF PAIRS AS INDICATED)
		CABLE, F.A. & P.C. AERIAL, SELF SUPPORTING, #19-(NUMBER OF PAIRS AS INDICATED)
		CABLE, F.A. & P.C., IN CONDUIT, #19-(NUMBER OF PAIRS AS INDICATED)
		DOWNLIGHT ASSEMBLY. (DWG. #850)
		LIGHT, TRAFFIC SAFETY ISLAND
		FLASHING BEACON & DOWNLIGHT

PROPOSED	EXISTING	DESCRIPTION
		310W PENDANT (240V)
		400W PENDANT (240V)
		250W PENDANT (240V)
		150W ACORN (120V)
		150W ACORN (240V)
		50W ACORN (240V)
		100W ACORN (240V)
		150W GLOBE (240V)
		100W GLOBE (240V)
		50W GLOBE (240V)

C 04-01-02	REVISED/REDRAW	R. POOL/B. I.
B 12-4-01	ADDED ORNAMENTAL SYMBOLS	
A 8-6-96	REDRAWN	
DATE	REVISION	
<b>STANDARD CODE FOR TRAFFIC SIGNALS/ STREET LIGHTING</b>		
CITY OF CHICAGO DEPT. OF STREETS AND SANITATION BUREAU OF ELECTRICITY DIVISION OF ELECTRICAL ENGINEERING		
DRAFTSMAN R. IVY	CHIEF DRAFTSMAN R. CARTER	ENGINEER R. POOL/R.C./W.T.
SUPERVISING ENGINEER	ELEC. DESIGN ENGR.	
ENGINEER OF ELECTRICITY		DWG. NO. <b>826</b>
DEPT. SUFF. OF CONSTRUCTION		
DEPUTY COMMISSIONER		
SIZE: 22" x 36"	SCALE:	DATE:

\* CITY OF CHICAGO BUREAU OF ELECTRICITY STANDARD DRAWINGS ARE PROVIDED IN ENGLISH UNITS.

REVISIONS		ILLINOIS DEPARTMENT OF TRANSPORTATION 115TH STREET OVER I-57 CITY OF CHICAGO BUREAU OF ELECTRICITY STANDARD DRAWINGS
NAME	DATE	
		SCALE: NONE DATE: 01-16-09 DRAWN BY: VG CHECKED BY: PV

**SINGH** SINGH & ASSOCIATES, INC.  
CONSULTING ENGINEERS

F.A.I. RTE.	SECTION	COUNTY	TOTAL SHEETS	SHEET NO.
57	1919.2B	COOK	119	43
STA.	TO STA.			
FED. ROAD DIST. NO.	ILLINOIS FED. AID PROJECT			

CONTRACT #60371

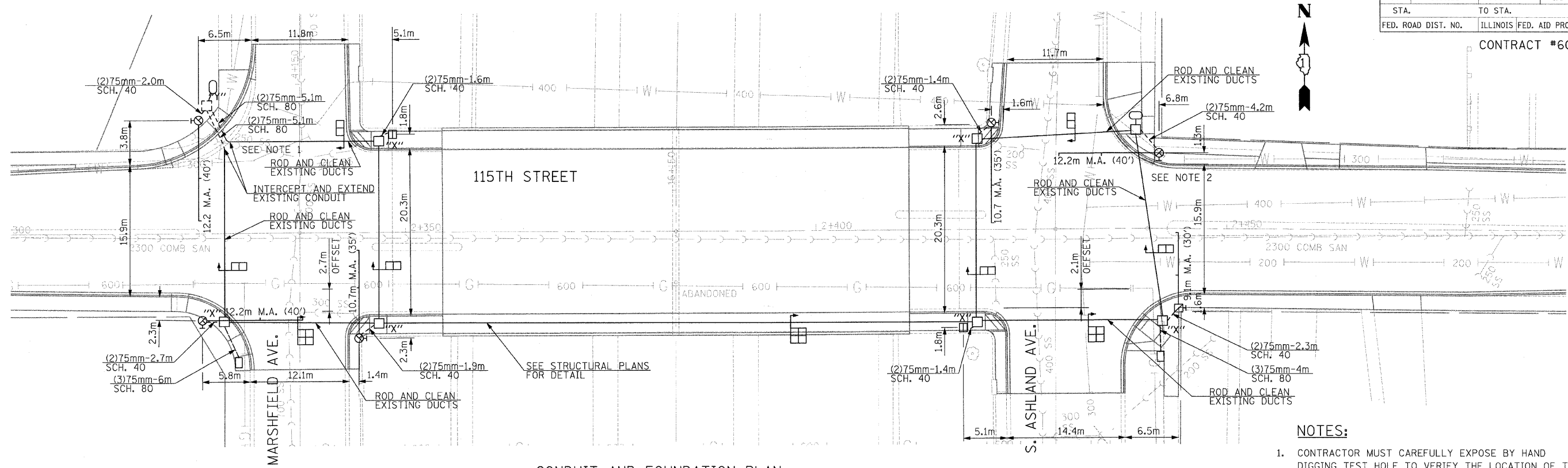
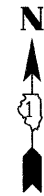

**NOTES:**

1. CONTRACTOR MUST CAREFULLY EXPOSE BY HAND DIGGING TEST HOLE TO VERIFY THE LOCATION OF THE EXISTING WATER MAIN BEFORE BREAKING DOWN AND REMOVING MANHOLE. CONTRACTOR MUST PROTECT EXISTING WATER MAIN DURING ALL CONSTRUCTION ACTIVITIES.
2. CONTRACTOR MUST CAREFULLY EXPOSE BY HAND DIGGING TEST HOLE TO VERIFY THE LOCATION OF THE EXISTING WATER MAIN BEFORE REMOVING EXISTING FOUNDATION AND EXCAVATING FOR PROPOSED FOUNDATION. IN NO CASE SHALL THE PROPOSED POLE FOUNDATION BE CLOSER THAN 460MM (OR EIGHTEEN INCHES) FROM THE EXTERIOR OF THE EXISTING WATER MAIN. CONTRACTOR MUST PROTECT EXISTING WATER MAIN DURING ALL CONSTRUCTION ACTIVITIES.

**CONSTRUCTION NOTES:**

- ALL FOUNDATIONS IN CONCRETE SIDE WALK TO BE PER DRAWING NO. 837.
- SEE DRAWING NO. 826 FOR TRAFFIC SIGNAL STANDARD CODES.
- ALL SIGNAL SECTION TO BE STANDARD 0.3m (12") SIZE
- ALL VEHICULAR SIGNAL TO BE 3 SECTION UNITS EXCEPT WHERE NOTED AND ALL PEDESTRIAN SIGNALS TO BE 1 SECTION UNITS WITH I.T.E. SYMBOLIC LENSES
- PEDESTRIAN SIGNALS TO BE INSTALLED BELOW VEHICULAR SIGNAL WHERE APPLICABLE
- FOREMAN TO SAW CUT A CLEAN JOINT BETWEEN CONCRETE SIDEWALK TO BE REMOVED AND THAT TO REMAIN IN PLACE.
- ROD AND CLEAN EXISTING CONDUITS WHEN REUSED.
- UNLESS OTHERWISE NOTED, ALL CONDUITS ARE POLYVINYLCHLORIDE (PVC)
- ALL DIMENSIONS ARE FROM FRONT FACE OF CURB UNLESS OTHERWISE INDICATED.
- FOREMAN TO CONTACT ALL UTILITIES PRIOR TO EXCAVATION FOR EXACT LOCATION OF THEIR UNDERGROUND FACILITIES.
- "X" - ADJUST FRAME AND LID
- "Y" - INSTALL 900mm x 1200mm x 1200mm (3' x 4' x 4') MANHOLE WITH 600mm (24") FRAME AND LID

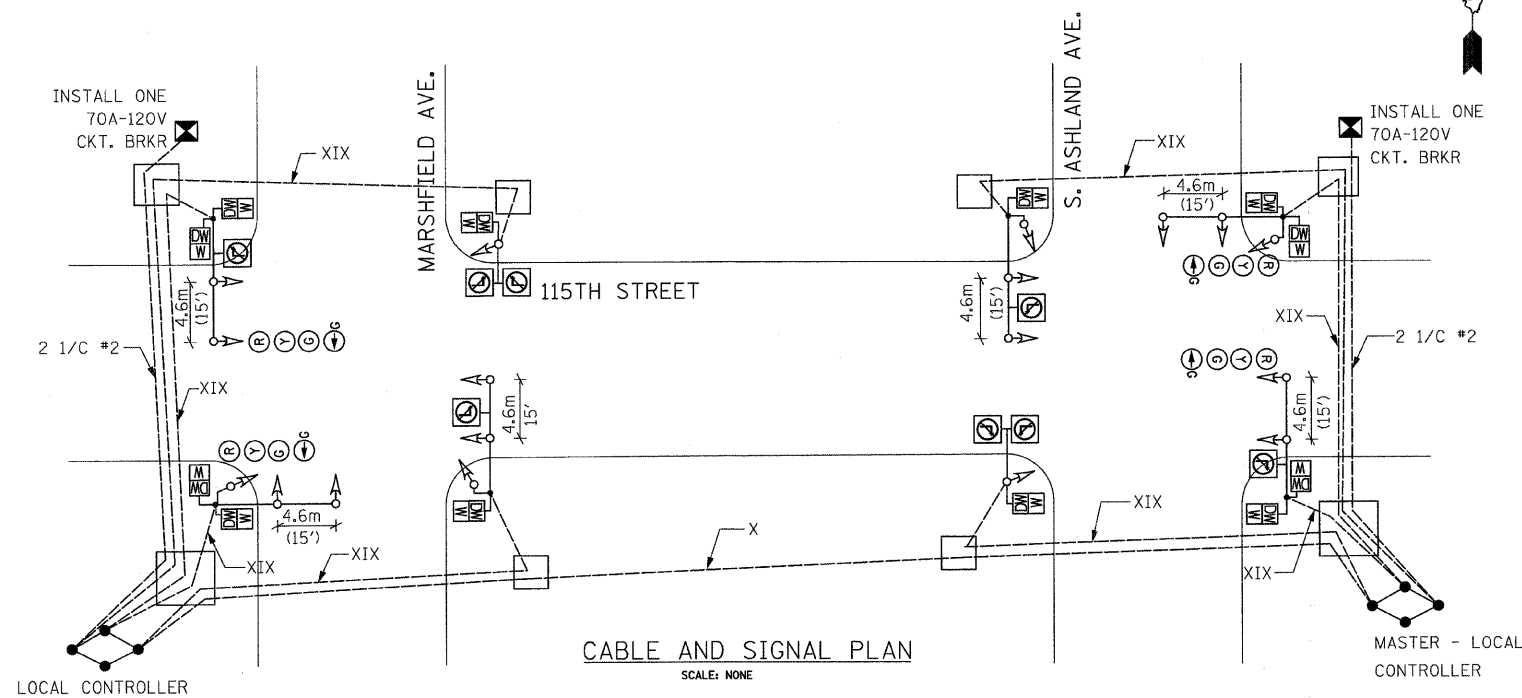

**SINGH SINGH & ASSOCIATES, INC.**  
CONSULTING ENGINEERS

A	DATE	REVISION
SUPERSEDES DWG. #		
WORK ORDER NO. _____		DATE _____
COST ALLOCATION ACCOUNT _____		
APPROPRIATION ACCOUNT _____		MATERIAL _____
		LABOR _____
<b>TRAFFIC CONTROL SIGNAL</b> <b>115TH ST. AT S. ASHLAND AVE.</b> <b>AND AT MARSHFIELD AVE.</b>		
<b>CITY OF CHICAGO</b> <small>DEPT. OF STREETS AND SANITATION</small> <small>BUREAU OF ELECTRICAL ENGINEERING</small>		
DRAFTSMAN:	CHIEF DRAFTSMAN:	ENGINEER:
SUPERVISING ENGINEER:	ELEC. DESIGN ENGR.	
ENGINEER OF ELECTRICITY:		DWG. NO.
GEN'L SUPT. OF ELECTRICITY:		22208
DEPUTY COMMISSIONER:		
SIZE:	SCALE: AS NOTED	DATE: 01-16-09

F.A.I. RTE.	SECTION	COUNTY	TOTAL SHEETS	SHEET NO.
57	1919.2B	COOK	119	44
STA.	TO STA.			
FED. ROAD DIST. NO.	ILLINOIS	FED. AID PROJECT		

**STREET LIGHTING REMOVAL NOTES**

- A - REMOVE STEEL POLE, ANCHOR BASE, 9m (29'-6"), 254mm (10") DIA. BOLT CIRCLE AND 3.6m (12') MAST ARM
- B - REMOVE STEEL POLE, ANCHOR BASE, 8.4m (27'-6"), 254mm (10") DIA. BOLT CIRCLE AND 3.6m (12') MAST ARM
- C - REMOVE STEEL POLE, ANCHOR BASE, 9m (29'-6") AND/OR 8.4m (27'-6") AND 3.6m (12') MAST ARM
- ( ) REMOVE ELECTRIC CABLE, TYPE AND LENGTH AS NOTED
- D - REMOVE 310W HPS AND/OR 195W HPS LUMINAIRE
- E - BREAK DOWN MANHOLE/HANDHOLE
- F - REMOVE STREET LIGHTING CONTROLLER & PEDESTAL, BREAK DOWN FOUNDATION
- G - REMOVE STREET LIGHTING SERVICE EQUIPMENT

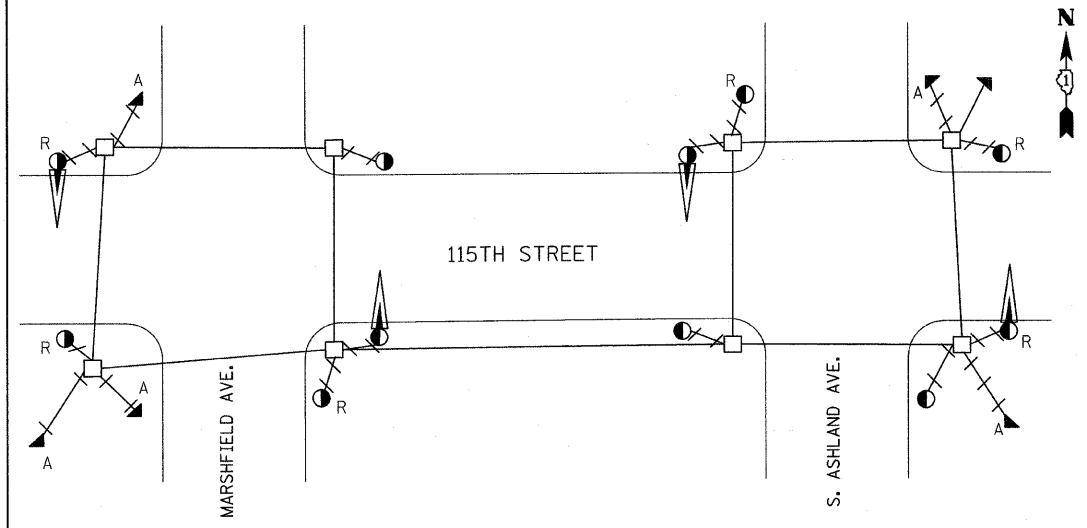

**TRAFFIC SIGNAL FOUNDATION REMOVAL**

**TRAFFIC SIGNAL REMOVAL NOTES**

- A - BREAKDOWN FOUNDATION TYPE A REMOVE CABLE AS SHOWN
- B - REMOVE TRAFFIC SIGNALS ( ) 2/C #6-90m
- C - REMOVE POST AND ATTACHED SIGNS ( ) 7/C #10-141m, 10/C #10&9#14-12m
- D - REMOVE CONTROLLER AND POST ( ) 14/C #10&13#14-158m
- E - BREAKDOWN HANDHOLE/MANHOLE ( ) 19/C 2#10&17#14-185m
- ( ) REMOVE FRAME COVER AND FILL IT WITH SAND ABANDON CONDUIT
- F - REMOVE ILLUMINATED SIGN
- G - REMOVE SERVICE EQUIPMENT
- H - REMOVE ALUMINUM MAST ARM ASSEMBLY
- R - BREAKDOWN LIGHTING FOUNDATION

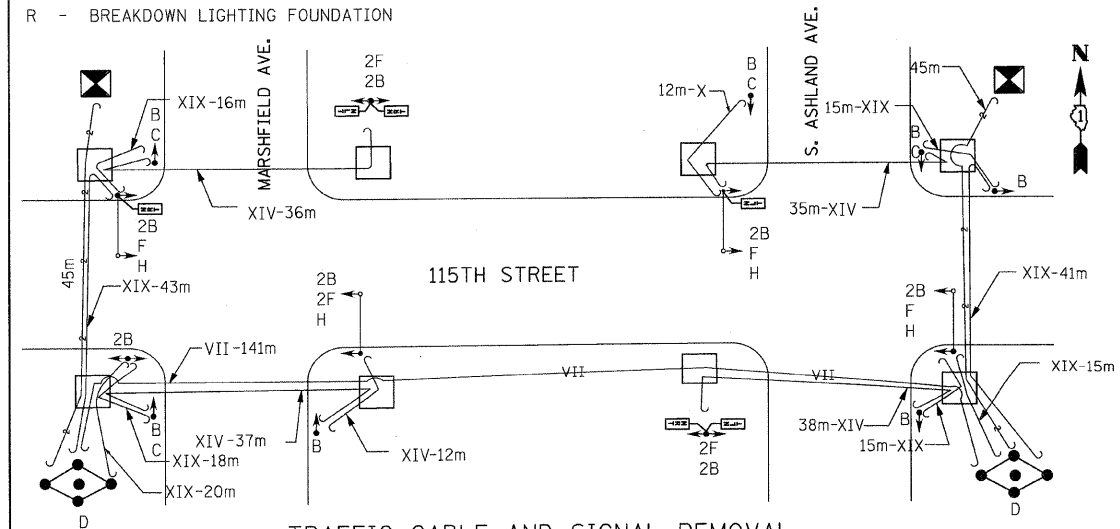

**TRAFFIC CABLE AND SIGNAL REMOVAL**

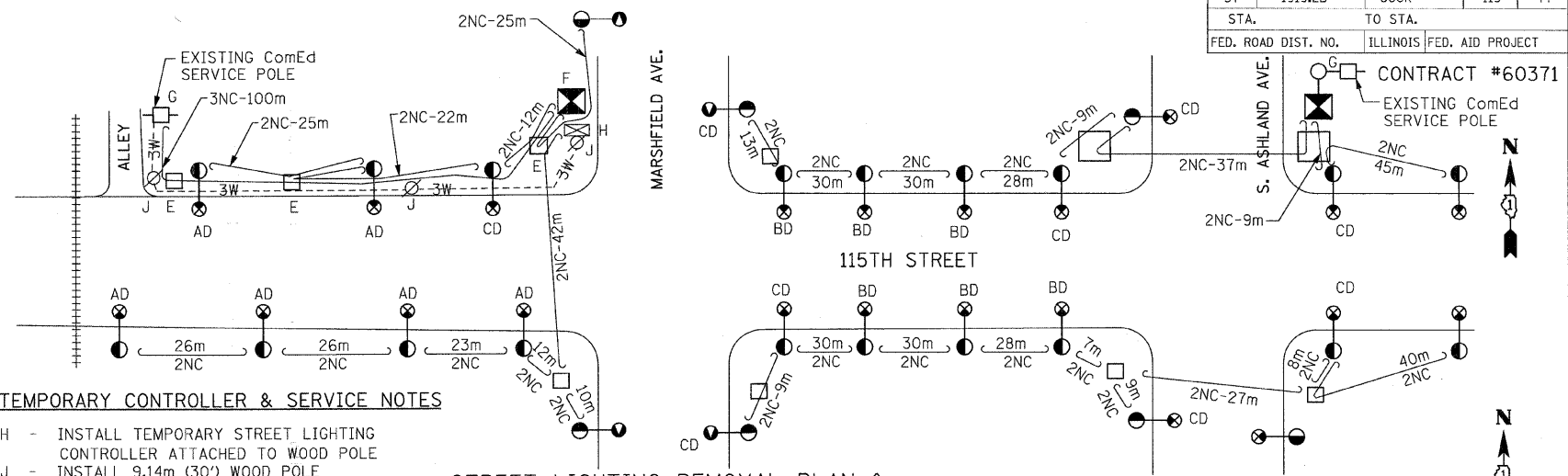

**TEMPORARY CONTROLLER & SERVICE NOTES**

- H - INSTALL TEMPORARY STREET LIGHTING CONTROLLER ATTACHED TO WOOD POLE
- J - INSTALL 9.14m (30') WOOD POLE
- 3W - INSTALL AERIAL WIRE 3-1/C NO. 2

**STREET LIGHTING REMOVAL PLAN & TEMPORARY CONTROLLER & SERVICE**

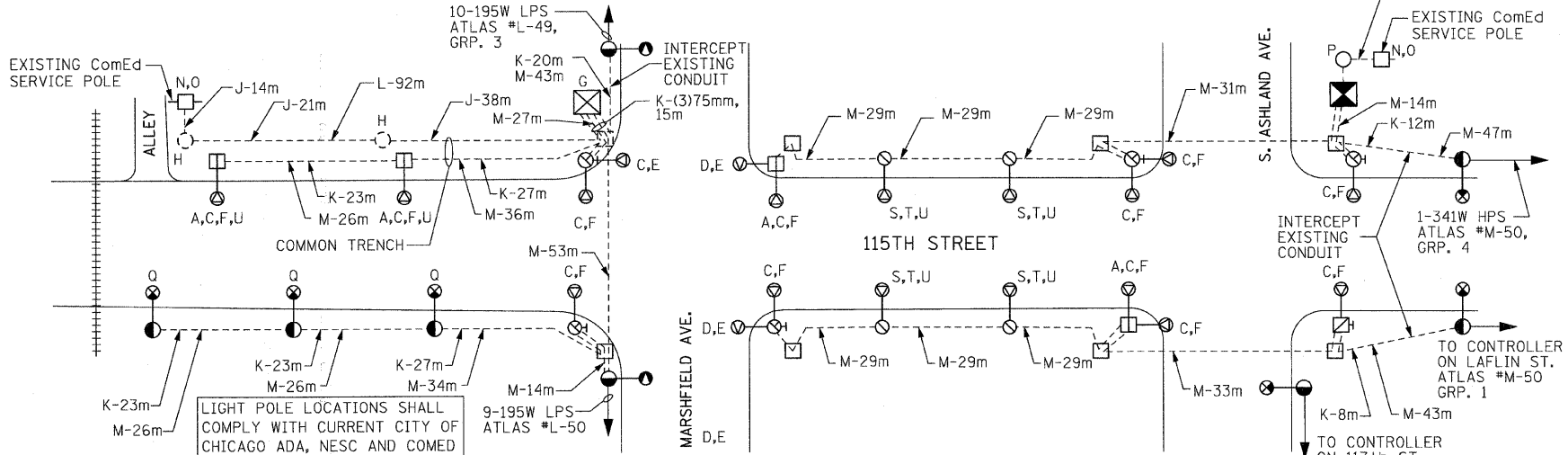

**STREET LIGHTING INSTALLATION PLAN**

**STREET LIGHTING INSTALLATION NOTES**

- A - INSTALL POLE, CITY STEEL, ANCHOR BASE, 10.5m (34'-6"), 7 GA. 254mm (10") DIA. AND 381mm (15") BOLT CIRCLE AND 600mmX2.7m (24"X9') FOUNDATION WITH 32mm (1 1/4") ANCHOR RODS, SEE BOE STANDARD DWG. #818.
- C - INSTALL LUMINAIRE, H.P.S.V. AND LAMP, 400W, 240V, WITH INTEGRAL BALLAST, M-C-III TYPE LIGHT DISTRIBUTION PATTERN.
- D - INSTALL LUMINAIRE, H.P.S.V. AND LAMP, 195W, 240V, WITH INTEGRAL BALLAST, M-C-III TYPE LIGHT DISTRIBUTION PATTERN.
- E - INSTALL 2.4m (8') MAST ARM.
- F - INSTALL 3.6m (12') MAST ARM.
- G - RELOCATE EXISTING STREET LIGHTING CONTROLLER ON NEW FOUNDATION.
- H - CONSTRUCT CIRCULAR HANDHOLE, 750mm (30") I.D. WITH 600mm (24") FRAME AND COVER, BOE STANDARD DWG. #867.
- J - INSTALL 65mm (2 1/2") GALVANIZED STEEL CONDUIT IN TRENCH, LENGTH AS INDICATED.
- K - INSTALL 50mm (2") SCH. 40 PVC CONDUIT IN TRENCH, OR AS INDICATED OTHERWISE, CONDUIT UNDER DRIVEWAYS SHALL BE SCH. 80, LENGTH AS INDICATED.
- L - INSTALL ELECTRIC SERVICE CABLE 3-1/C #2/0, 600V EPR IN CONDUIT, LENGTH AS INDICATED.
- M - INSTALL STREET LIGHTING CABLE, 3TC (2-1/C #6 & 1/C #8) IN CONDUIT, LENGTH AS INDICATED.
- N - INSTALL 50mm (2") CONDUIT RISER UP SERVICE POLE AND 50mm (2") SERVICE HEAD.
- O - INSTALL ELECTRIC SERVICE EQUIPMENT, BOE STANDARD DWG. #11925.
- P - DRILL/CLEAN EXISTING HANDHOLE/MANHOLE.
- Q - RELOCATE EXISTING LIGHT POLE, ARM AND LUMINAIRE ON NEW FOUNDATION, 1.6m (5'-6") BEHIND FACE OF CURB.
- S - INSTALL POLE, CITY STEEL, ANCHOR BASE, 9.90m (32'-6") M.H., 216mm (8 1/2") DIAMETER, AND 292mm (11 1/2") BOLT CIRCLE WITH 25mm (1") ANCHOR RODS, SEE BOE STANDARD DWG. #762.
- T - INSTALL 400W HPS LUMINAIRE AND 3.6m (12') MAST ARM. SEE BOE STANDARD DWG. #839.
- U - MATERIAL PROVIDED BY CITY OF CHICAGO

DATE	REVISION
SUPERSEDES DWG. #	
WORK ORDER NO.	DATE
COST ALLOCATION ACCOUNT	
APPROPRIATION ACCOUNT	MATERIAL LABOR
<b>TRAFFIC SIGNAL REMOVAL AND STREET LIGHTING REMOVAL AND INSTALLATION PLAN</b> 115TH ST. AT S. ASHLAND AVE. AND AT MARSHFIELD AVE.	
<b>CITY OF CHICAGO</b> DEPT. OF STREETS AND SANITATION BUREAU OF ELECTRICITY DIVISION OF ELECTRICAL ENGINEERING	
DRAFTSMAN:	CHIEF DRAFTSMAN: ENGINEER:
SUPERVISING ENGINEER:	ELEC. DESIGN ENGR.
ENGINEER OF ELECTRICITY:	DWG. NO.
GEN'L SUPT. OF ELECTRICITY:	
DEPUTY COMMISSIONER:	
SIZE:	SCALE: NONE DATE: 01-16-09

**SINGH SINGH & ASSOCIATES, INC.**  
CONSULTING ENGINEERS

F.A.I. RTE.	SECTION	COUNTY	TOTAL SHEETS	SHEET NO.
57	1919.2B	COOK	119	45
STA.		TO STA.		
FED. ROAD DIST. NO.		ILLINOIS FED. AID PROJECT		

CONTRACT #60371

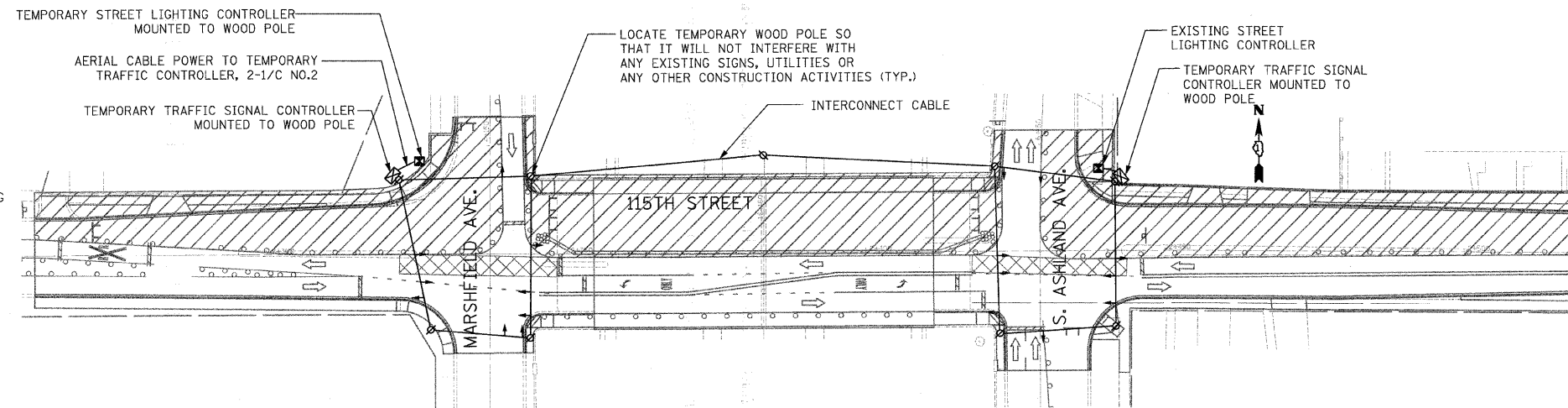
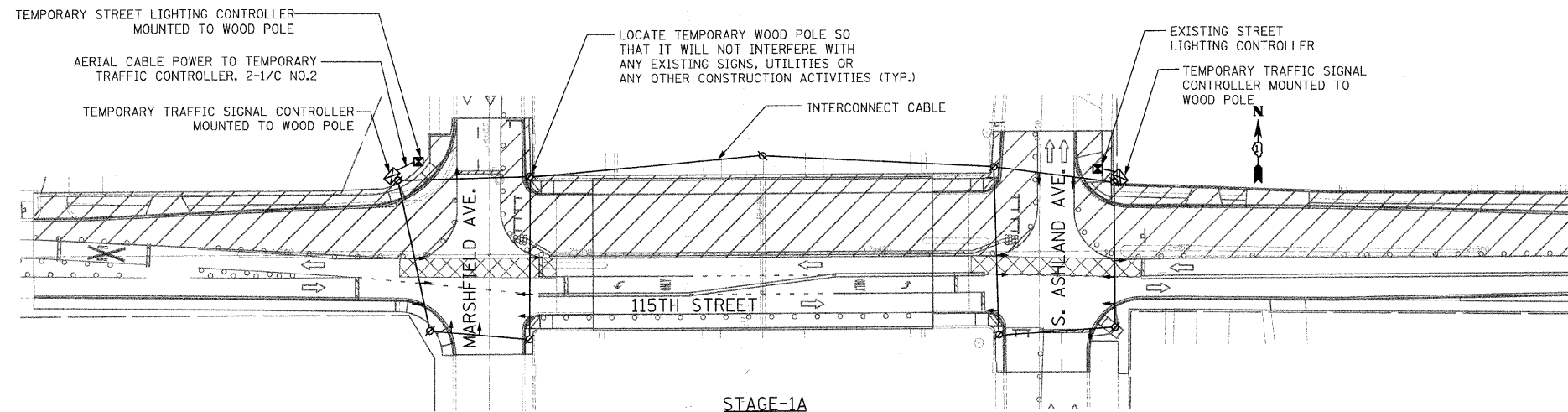

- TEMPORARY TRAFFIC SIGNAL LEGEND**
- ← TEMPORARY TRAFFIC SIGNAL HEAD SPAN, WIRE, LOCATION VARIES, BETWEEN STAGES 1A & 1B, 2A & 2B
  - ⊗ WOOD POLE, (CLASS 5 OR BETTER) 45' MINIMAL, INSTALLED IN STAGE 1A, TO REMAIN IN PLACE THROUGHOUT THE CONSTRUCTION PERIOD
  - ⊠ PROPOSED TEMPORARY TRAFFIC SIGNAL CONTROLLER
  - TEMPORARY SPAN WIRE, TETHER WIRE & CABLE
  - ⊙ TEMPORARY STREET LIGHT WITH 8' MAST ARM BRACKET MOUNTED, 310 WATT HPS
  - ⊠ EXISTING STREET LIGHTING CONTROLLER
  - ⊠ TEMPORARY STREET LIGHTING CONTROLLER MOUNTED TO WOOD POLE

**NOTE 1:**

THE CONTRACTOR SHALL OBTAIN ELECTRICAL SERVICE FOR THE TEMPORARY TRAFFIC SIGNAL CONTROLLER VIA THE EXISTING LIGHTING CONTROLLER. EXTRA PRECAUTION MUST BE TAKEN WHEN PLACING STRAPS, MOUNTING CONDUIT AND RUNNING CABLE. THE CONTRACTOR SHALL PROVIDE ALL NECESSARY EQUIPMENT, TOOLS, AND DEVICES AS REQUIRED FOR PROPER SERVICE CONNECTIONS. ANY DAMAGES TO THE EXISTING LIGHTING CONTROLLER OR OTHER EQUIPMENT SHALL BE REPAIRED OR REPLACED BY THE CONTRACTOR AT HIS/HER EXPENSE. ALL TEMPORARY SERVICE AND CONNECTIONS SHALL BE PAID FOR AT THE CONTRACT PRICE PER EACH FOR "TEMPORARY TRAFFIC SIGNAL INSTALLATION".

**NOTE 2:**

THE CONTRACTOR SHALL UTILIZE EXISTING LIGHTING DURING STAGE 1A & 1B CONSTRUCTION. PROVIDE AERIAL CABLES, SECONDARY RACKS, SPLICE KITS, ETC, AS REQUIRED TO CONTINUE THE EXISTING LIGHTING CIRCUIT AS SHOWN TO THE NEARBY FIXTURES. ALL TEMPORARY STREET LIGHTING SERVICES, FIELD INVESTIGATIONS, CONNECTIONS, CABLES ETC. SHALL BE PAID FOR AS PART OF THE CONTRACT UNIT PRICE PER LUMP SUM FOR "MAINTENANCE OF EXISTING STREET LIGHTING SYSTEM".

**NOTE 3:**

DURING STAGE 2A CONSTRUCTION, THE CONTRACTOR SHALL UTILIZE THE NEW STREET LIGHTS INSTALLED ON THE NORTH SIDE OF THE BRIDGE, REARRANGMENT OF THE TEMPORARY AERIAL WIRE AND CABLE MAY BE REQUIRED TO CONTINUE SERVICE TO ADJACENT STREET LIGHTING. ALL WORK SHALL BE PAID FROM UNDER THE CONTRACT UNIT PRICE PER LUMP SUM FOR "MAINTENANCE OF EXISTING STREET LIGHTING SYSTEM".

**NOTE 4:**

THE CONTRACTOR SHALL PROVIDE ALL NECESSARY MATERIAL, EQUIPMENT AND LABOR AS REQUIRED TO MAINTAIN POWER TO THE BRIDGE.

**NOTE 5:**

MAINTAIN A 6.1m VERTICAL CLEARANCE OF AERIAL ELECTRIC CABLE SPANNING THE EXPRESSWAY LANES OF TRAVEL.

REVISIONS		ILLINOIS DEPARTMENT OF TRANSPORTATION
NAME	DATE	
		<b>115TH STREET OVER I-57 TEMPORARY TRAFFIC SIGNALIZATION STAGES, 1A &amp; 1B</b>

**SINGH** SINGH & ASSOCIATES, INC.  
CONSULTING ENGINEERS

SCALE: 1:500  
DATE: 01-16-09

DRAWN BY: BD  
CHECKED BY: RD

F.A.I. RTE.	SECTION	COUNTY	TOTAL SHEETS	SHEET NO.
57	1919.2B	COOK	119	46
STA.		TO STA.		
FED. ROAD DIST. NO.		ILLINOIS FED. AID PROJECT		

CONTRACT #60371

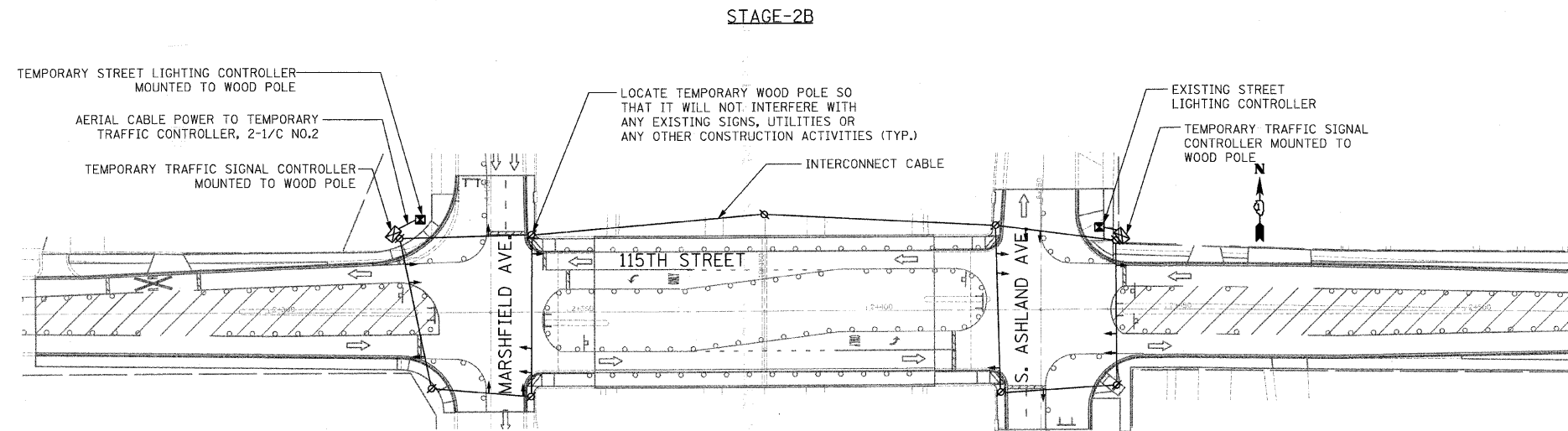
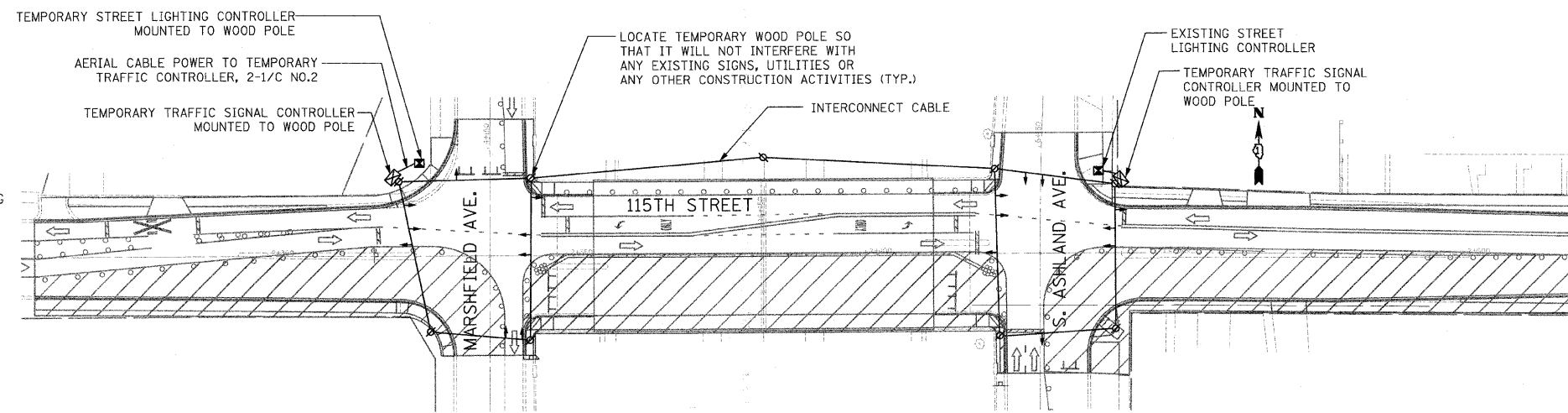
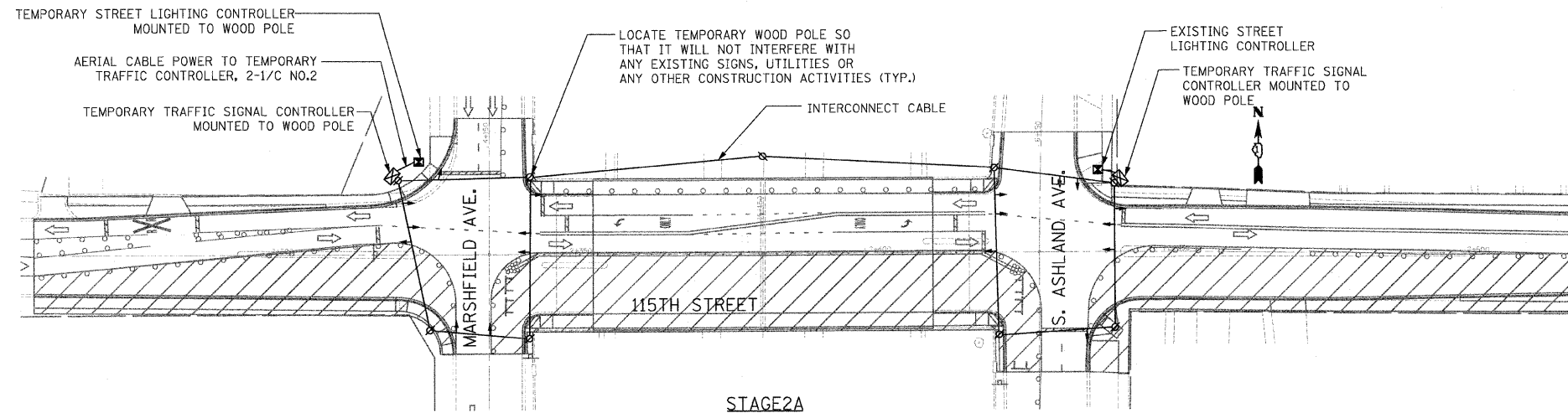

- TEMPORARY TRAFFIC SIGNAL LEGEND**
- ← TEMPORARY TRAFFIC SIGNAL HEAD SPAN, WIRE, LOCATION VARIES, BETWEEN STAGES 1A & 1B, 2A & 2B
  - ⊘ WOOD POLE, (CLASS 5 OR BETTER) 45' MINIMAL, INSTALLED IN STAGE 1A, TO REMAIN IN PLACE THROUGHOUT THE CONSTRUCTION PERIOD
  - ⊠ PROPOSED TEMPORARY TRAFFIC SIGNAL CONTROLLER
  - TEMPORARY SPAN WIRE, TETHER WIRE & CABLE
  - ⊙ TEMPORARY STREET LIGHT WITH 8' MAST ARM BRACKET MOUNTED, 310 WATT HPS
  - ⊠ EXISTING STREET LIGHTING CONTROLLER
  - ⊠ TEMPORARY STREET LIGHTING CONTROLLER MOUNTED TO WOOD POLE

**NOTE 1:**

THE CONTRACTOR SHALL OBTAIN ELECTRICAL SERVICE FOR THE TEMPORARY TRAFFIC SIGNAL CONTROLLER VIA THE EXISTING LIGHTING CONTROLLER. EXTRA PRECAUTION MUST BE TAKEN WHEN PLACING STRAPS, MOUNTING CONDUIT AND RUNNING CABLE. THE CONTRACTOR SHALL PROVIDE ALL NECESSARY EQUIPMENT, TOOLS, AND DEVICES AS REQUIRED FOR PROPER SERVICE CONNECTIONS. ANY DAMAGES TO THE EXISTING LIGHTING CONTROLLER OR OTHER EQUIPMENT SHALL BE REPAIRED OR REPLACED BY THE CONTRACTOR AT HIS/HER EXPENSE. ALL TEMPORARY SERVICE AND CONNECTIONS SHALL BE PAID FOR AT THE CONTRACT PRICE PER EACH FOR "TEMPORARY TRAFFIC SIGNAL INSTALLATION".

**NOTE 2:**

THE CONTRACTOR SHALL UTILIZE EXISTING LIGHTING DURING STAGE 1A & 1B CONSTRUCTION. PROVIDE AERIAL CABLES, SECONDARY RACKS, SPLICE KITS, ETC. AS REQUIRED TO CONTINUE THE EXISTING LIGHTING CIRCUIT AS SHOWN TO THE NEARBY FIXTURES. ALL TEMPORARY STREET LIGHTING SERVICES, FIELD INVESTIGATIONS, CONNECTIONS, CABLES ETC. SHALL BE PAID FOR AS PART OF THE CONTRACT UNIT PRICE PER LUMP SUM FOR "MAINTENANCE OF EXISTING STREET LIGHTING SYSTEM".

**NOTE 3:**

DURING STAGE 2A CONSTRUCTION, THE CONTRACTOR SHALL UTILIZE THE NEW STREET LIGHTS INSTALLED ON THE NORTH SIDE OF THE BRIDGE, REARRANGMENT OF THE TEMPORARY AERIAL WIRE AND CABLE MAY BE REQUIRED TO CONTINUE SERVICE TO ADJACENT STREET LIGHTING. ALL WORK SHALL BE PAID FROM UNDER THE CONTRACT UNIT PRICE PER LUMP SUM FOR "MAINTENANCE OF EXISTING STREET LIGHTING SYSTEM".

**NOTE 4:**

THE CONTRACTOR SHALL PROVIDE ALL NECESSARY MATERIAL, EQUIPMENT AND LABOR AS REQUIRED TO MAINTAIN POWER TO THE BRIDGE.

**NOTE 5:**

MAINTAIN A 6.1m VERTICAL CLEARANCE OF AERIAL ELECTRIC CABLE SPANNING THE EXPRESSWAY LANES OF TRAVEL.

REVISIONS	
NAME	DATE

ILLINOIS DEPARTMENT OF TRANSPORTATION  
 115TH STREET OVER I-57  
 TEMPORARY TRAFFIC SIGNALIZATION  
 STAGES, 2A, 2B & 3  
 SCALE: 1:500  
 DATE: 01-16-09  
 DRAWN BY: BD  
 CHECKED BY: RD

**SINGH** SINGH & ASSOCIATES, INC.  
 CONSULTING ENGINEERS

F.A.I. RTE.	SECTION	COUNTY	TOTAL SHEETS	SHEET NO.
57	1919.2B	COOK	119	47
STA.		TO STA.		
FED. ROAD DIST. NO.		ILLINOIS FED. AID PROJECT		

CONTRACT #60371

**NOTES:**

1. THE CONTROL EQUIPMENT FOR ALL THE TEMPORARY TRAFFIC SIGNAL(S) SHALL BE PROVIDED BY THE CONTRACTOR UNLESS OTHERWISE STATED IN THE PLANS. FOR PROJECTS WITH MULTIPLE TEMPORARY SIGNAL INSTALLATIONS, ALL CONTROLLERS SHALL BE MADE OF THE SAME MANUFACTURER, BRAND AND MODEL NUMBER WITH CURRENT SOFTWARE INSTALLED
2. TRAFFIC SIGNAL CONTROLLERS USED FOR TEMPORARY TRAFFIC SIGNALS SHALL BE ACTUATED NEMA PROCESSOR BASED INSTALLED IN THE CABINETS WITH 8 PHASE BACK PANELS CAPABLE OF SUPPLYING 255 SECONDS OF CYCLE LENGTH AND INDIVIDUAL PHASE LENGTH SETTING UP TO 90 SECONDS. THE TEMPORARY SIGNAL CONTROLLER SHALL BE CAPABLE OF PROVIDING ADJUSTABLE ALL RED CLEARANCE SETTING OF UP TO 30 SECONDS IN LENGTH.
3. ALL CONTROLLERS USED FOR TEMPORARY TRAFFIC SIGNALS SHALL MEET OR EXCEED THE REQUIREMENTS OF ARTICLE 1085.45 OF THE STANDARD SPECIFICATIONS FOR ROAD AND BRIDGE CONSTRUCTION WITH REGARDS TO INTERNAL TIME BASE COORDINATION AND PREEMPTION.
4. ALL TRAFFIC SIGNAL SECTIONS AND PEDESTRIAN SIGNAL SECTIONS SHALL BE OF THE 305MM TYPE. THE TEMPORARY TRAFFIC SIGNAL HEADS SHALL BE PLACED AS INDICATED ON THE TEMPORARY TRAFFIC SIGNAL PLAN OR AS DIRECTED BY THE ENGINEER. THE CONTRACTOR SHALL FURNISH ENOUGH CABLE SLACK TO RELOCATE HEADS TO ANY POSITION ON THE SPAN WIRE OR AT LOCATIONS ILLUSTRATED ON THE PLANS FOR CONSTRUCTION STAGING. TEMPORARY TRAFFIC SIGNAL SHALL REMAIN IN OPERATION DURING ALL SIGNAL HEAD RELOCATIONS. EACH TEMPORARY TRAFFIC SIGNAL HEAD SHALL HAVE ITS OWN CABLE FROM THE CONTROLLER TO THE SIGNAL HEAD.
5. THE CONTRACTOR SHALL REMOVE THE EXISTING STREET NAME AND INTERSECTION REGULATORY SIGNS FROM EXISTING POLES THAT ARE REQUIRED TO BE REMOVED OR RELOCATED DUE TO CONSTRUCTION. THE RELOCATED SIGNS SHALL BE SECURELY FASTENED TO THE TEMPORARY WOOD POLE AND/OR THE SIGNAL SPAN WIRE. THE BUREAU OF TRAFFIC, EXCLUSIVELY, WILL DETERMINE THE LOCATIONS OF ALL SIGNS THAT ARE DIRECTLY OR INDIRECTLY INVOLVED WITH THE PROJECT.
6. THE SPAN WIRE FOR TEMPORARY TRAFFIC SIGNAL HEAD AND CABLE SHALL BE 10MM NOMINAL DIAMETER, 7 STRAND, ZINC COATED WIRE CONFORMING ASTM A475, UTILITY GRADE OR BETTER
7. THE TEMPORARY WOOD POLES FURNISHED AND INSTALLED UNDER STAGES 1A & B, 2A & B SHALL BE LEFT IN PLACE THROUGHOUT EACH CONSTRUCTION STAGE. THE CONTRACTOR MUST LOCATE EACH WOOD POLE IN A LOCATION WHERE IT WOULD NOT RESTRICT THE PROPOSED CONSTRUCTION UNDER PRECEDING STAGES. THE CONTRACTOR IS RESPONSIBLE FOR COORDINATING AND SCHEDULING ALL TEMPORARY AND PERMANENT TRAFFIC SIGNAL INSTALLATIONS WITH HIS CONSTRUCTION SCHEDULE. FINAL COORDINATION AND SEQUENCING SHALL BE APPROVED BY THE CDOT MAINTENANCE OF TRAFFIC AND THE ENGINEER.
8. WOOD POLES SHALL BE FULL-TREATED SOUTHERN PINE, DOULAS FIR, OR WESTERN RED CEDAR CONFORMING TO THE AMERICAN NATIONAL STANDARD SPECIFICATIONS AND DIMENSIONS FOR WOOD POLES. THE PRESERVATIVE TREATMENT SHALL CONFORM TO THE AMERICAN PRESERVERS ASSOCIATION STANDARD C4. THE DOWN GUY FOR WOOD POLES SHALL MEET THE REQUIREMENT OF ASTM A 475 UTILITY GRADE OR BETTER.
9. ALL LABOR AND MATERIAL REQUIRED TO COMPLY WITH THESE REQUIREMENTS SHALL BE CONSIDERED INCIDENTAL TO THE CONTRACT UNIT PRICE EACH FOR TEMPORARY TRAFFIC SIGNAL INSTALLATION.
10. TEMPORARY TRAFFIC SIGNALS MUST BE IN PLACE, TESTED, AND FULLY OPERATIONAL PRIOR TO REMOVAL OF EXISTING SIGNALS. THE CITY USES COMBINATION TRAFFIC SIGNAL AND STREET LIGHTING POLES; THEREFORE, THE CONTRACTOR SHALL PROVIDE TEMPORARY PROVISIONS TO MAINTAIN POWER TO THE ROADWAY LIGHTING REMAINING IN THE SERVICE. ALL TRAFFIC SIGNAL EQUIPMENT REMOVED BY THE CONTRACTOR SHALL BE TURNED OVER TO THE CITY OF CHICAGO, BUREAU OF ELECTRICITY. PAYMENT FOR THIS WORK WILL BE MADE UNDER THE CONTRACT UNIT PRICE PER EACH FOR "TEMPORARY TRAFFIC SIGNAL INSTALLATION".

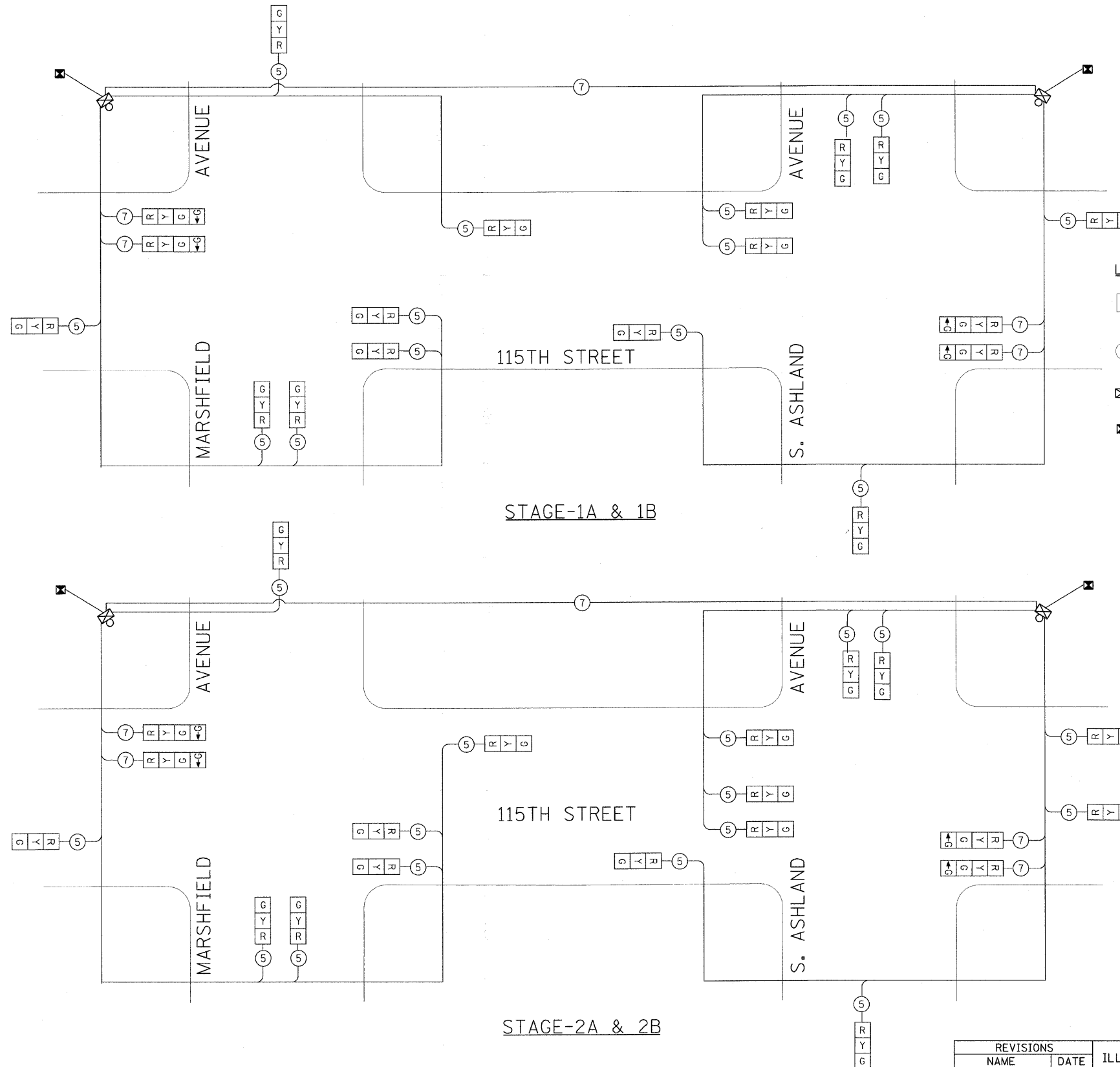

**LEGEND - TEMPORARY CABLE PLAN**

- R SIGNAL SECTION 300mm
- 2 INDICATES NUMBER OF CONDUCTORS IN CABLE, ALL CONDUCTORS SHALL BE NO. 14 A.W.G. WIRE UNLESS OTHERWISE NOTED
- X TEMPORARY CONTROLLER CABINET, SEE NOTE 2
- X EXISTING STREET LIGHTING CONTROLLER

REVISIONS	
NAME	DATE

ILLINOIS DEPARTMENT OF TRANSPORTATION  
 115TH STREET OVER I-57  
 TEMPORARY CABLE DIAGRAM AND  
 GENERAL NOTES  
 (STAGES-1A & 1B, STAGES-2A & 2B)  
 SCALE: NONE  
 DATE: 01-16-09  
 DRAWN BY: BD  
 CHECKED BY: RD

**SINGH** SINGH & ASSOCIATES, INC.  
 CONSULTING ENGINEERS

F.A.I. RTE.	SECTION	COUNTY	TOTAL SHEETS	SHEET NO.
57	1919.2B	COOK	119	48
STA.		TO STA.		
FED. ROAD DIST. NO.		ILLINOIS FED. AID PROJECT		

CONTRACT #60371

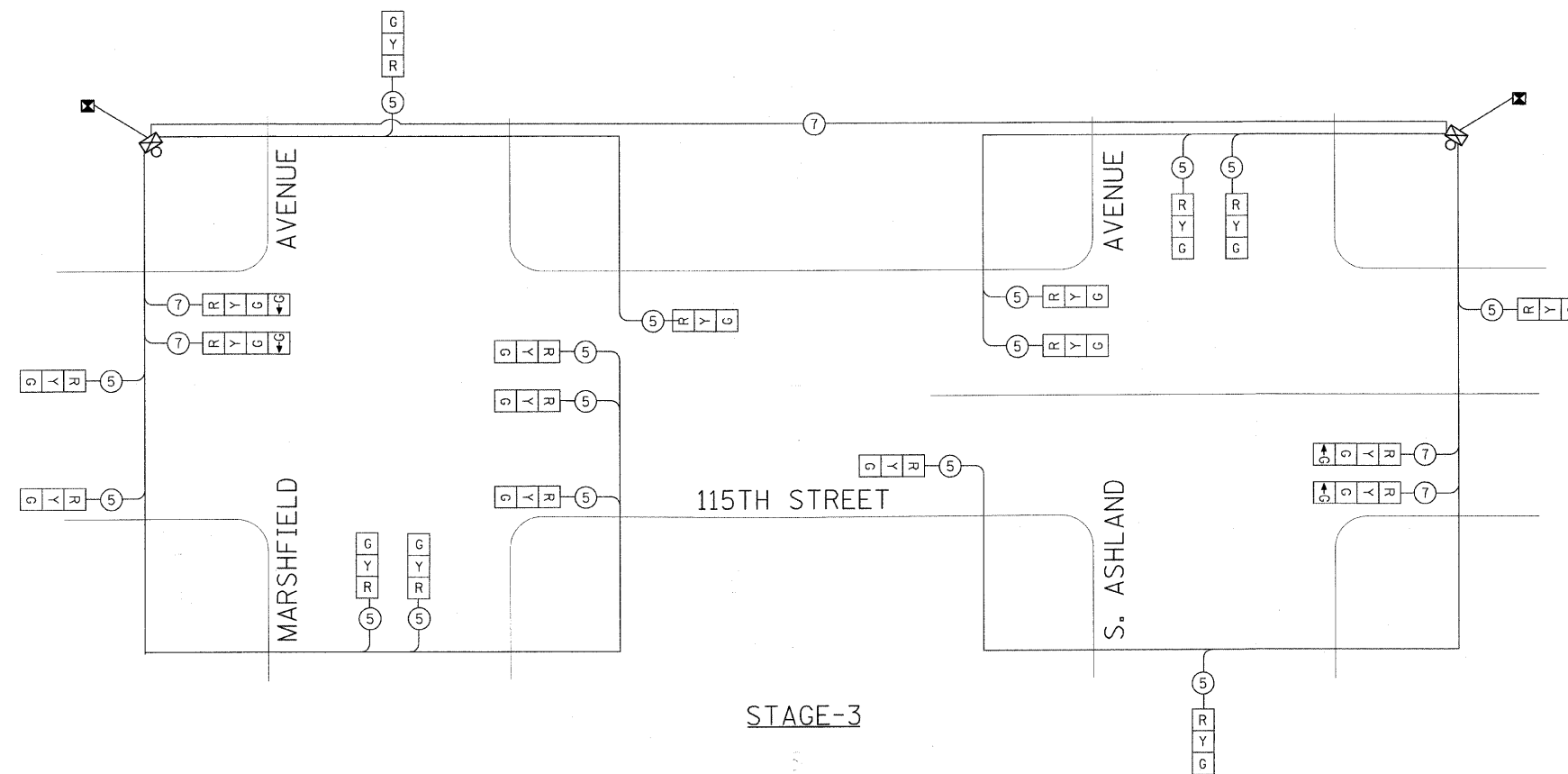

**LEGEND - TEMPORARY CABLE PLAN**

- R SIGNAL SECTION 300mm
- ② INDICATES NUMBER OF CONDUCTORS IN CABLE, ALL CONDUCTORS SHALL BE NO. 14 A.W.G. WIRE UNLESS OTHERWISE NOTED
- TEMPORARY CONTROLLER CABINET, SEE NOTE 2
- EXISTING STREET LIGHTING CONTROLLER

REVISIONS	
NAME	DATE

ILLINOIS DEPARTMENT OF TRANSPORTATION

115TH STREET OVER I-57  
TEMPORARY CABLE DIAGRAM  
AND GENERAL NOTES (STAGE-3)

SCALE: NONE  
DATE: 01-16-09

DRAWN BY: BD  
CHECKED BY: RD

**SINGH** SINGH & ASSOCIATES, INC.  
CONSULTING ENGINEERS



F.A.I. RTE.	SECTION	COUNTY	TOTAL SHEETS	SHEET NO.
57	1919.2B	COOK	119	49
STA.		TO STA.		
FED. ROAD DIST. NO.		ILLINOIS FED. AID PROJECT		

CONTRACT #60371

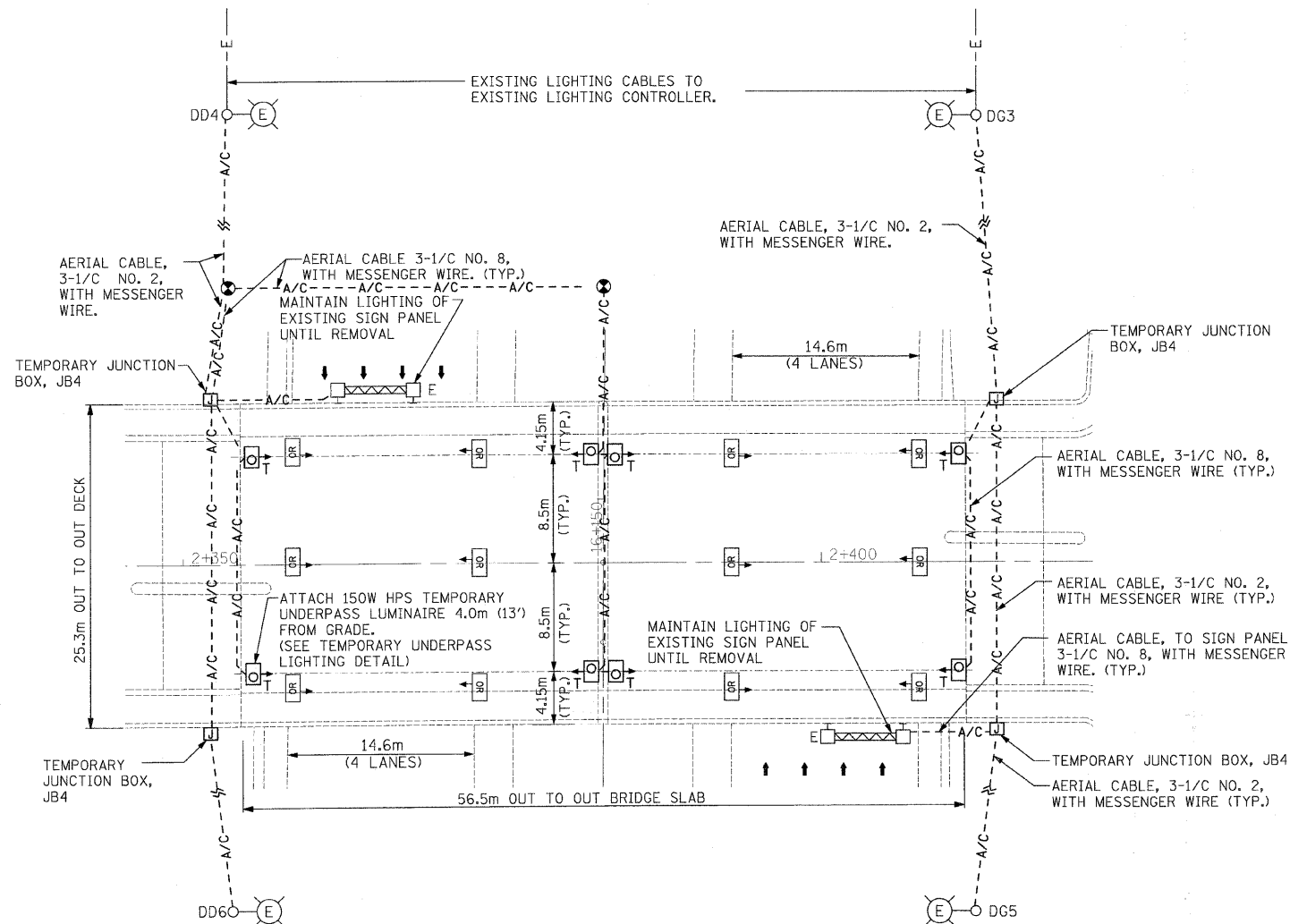

PROPOSED TEMPORARY AND REMOVAL OF EXISTING UNDERPASS LIGHTING

LEGEND

- PROPOSED    EXISTING
- INSTALL TEMPORARY LIGHTING LUMINAIRE, 150W HPS. ATTACH TO FACE OF PIER AND ABUTMENT.
  - JUNCTION BOX ATTACHED TO STRUCTURE, SIZE AS NOTED.
  - TEMPORARY WOOD POLE, 12.2m.
  - EXISTING LIGHTING UNIT TO REMAIN IN PLACE, CIRCUIT NUMBER AS NOTED.
  - EXISTING LIGHTED SIGN STRUCTURE - BRIDGE MOUNT TYPE.
  - EXISTING UNIT DUCT
  - TEMPORARY AERIAL CABLE, SIZE AS NOTED.

BILL OF MATERIALS

DESCRIPTION	UNIT	QUANTITY
JUNCTION BOX, CAST IRON, ATTACHED TO STRUCTURE, 250MM X 250MM X 150MM	EACH	4
AERIAL CABLE, 4-1/C NO. 8, WITH MESSENGER WIRE	METER	135
TEMPORARY WOOD POLE, 12.19 METER, CLASS 4	EACH	2
UNDERPASS LUMINAIRE, 150 WATT, HIGH PRESSURE SODIUM VAPOR	EACH	8
REMOVAL OF EXISTING LIGHTING UNIT, NO SALVAGE	EACH	12
AERIAL CABLE, 3-1/C NO. 2 WITH MESSENGER WIRE	METER	215
TEMPORARY UNDERPASS LIGHTING INSTALLATION AND REMOVAL	L SUM	1

JUNCTION BOX SCHEDULE

NO.	SIZE (MM)	DESCRIPTION	QUANTITY
JB4	250MM X 250MM X 150MM	CAST IRON, ATTACHED TO STRUCTURE	4

CONSTRUCTION NOTES:

- MAINTAIN A 6.1m VERTICAL CLEARANCE OF AERIAL ELECTRIC CABLE SPANNING THE EXPRESSWAY LANES OF TRAVEL.
- CONTRACTOR SHALL MAKE ANY ADJUSTMENTS NECESSARY TO PROTECTIVE SHIELDING TO ACCOMMODATE REMOVAL OF EXISTING UNDERPASS LUMINAIRES. THIS WORK SHALL BE CONSIDERED INCIDENTAL TO "REMOVAL OF EXISTING LIGHTING UNIT, NO SALVAGE" PAY ITEM.

SINGH SINGH & ASSOCIATES, INC. CONSULTING ENGINEERS

REVISIONS		ILLINOIS DEPARTMENT OF TRANSPORTATION
NAME	DATE	
		115TH STREET OVER I-57 TEMPORARY UNDERPASS LIGHTING PLAN  SCALE: 1:250 DATE: 01-16-09

SCALE: 1:250  
DATE: 01-16-09







DRAWN BY: BD  
CHECKED BY: RD

F.A.I. RTE.	SECTION	COUNTY	TOTAL SHEETS	SHEET NO.
57	1919.2B	COOK	119	50
STA.		TO STA.		
FED. ROAD DIST. NO.		ILLINOIS FED. AID PROJECT		

CONTRACT #60371

**LEGEND**

PROPOSED    EXISTING

-  UNDERPASS LIGHTING LUMINAIRE, 100W HPS, PENDANT MOUNTED, OFFSET 0.6m (2FT) FROM EDGE OF TRAVELED PAVEMENT, CIRCUIT NUMBER AS NOTED.
-  JUNCTION BOX ATTACHED TO STRUCTURE, SIZE AS NOTED.
-  CONDUIT ATTACHED TO STRUCTURE, GALVANIZED STEEL, PVC COATED, SIZE AS NOTED.
-  UNIT DUCT, WITH 3-1/2 NO. 4 AND 1/2 NO. 6 GROUND, 600V (EPR-TYPE RHW), 30 MM DIA. POLYETHYLENE
-  EXISTING LIGHTING UNIT TO REMAIN IN PLACE, CIRCUIT NUMBER AS NOTED.
-  EXISTING LIGHTED SIGN STRUCTURE-BRIDGE MOUNT TYPE.

**BILL OF MATERIALS**

DESCRIPTION	UNIT	QUANTITY
CONDUIT ATTACHED TO STRUCTURE, 25MM DIA. GALVANIZED STEEL, PVC COATED	METER	132
CONDUIT ATTACHED TO STRUCTURE, 65MM DIA. GALVANIZED STEEL, PVC COATED	METER	54
JUNCTION BOX, STAINLESS STEEL, ATTACHED TO STRUCTURE, 150MM X 150MM X 100MM	EACH	8
JUNCTION BOX, STAINLESS STEEL, ATTACHED TO STRUCTURE, 300MM X 250MM X 150MM	EACH	4
JUNCTION BOX, STAINLESS STEEL, ATTACHED TO STRUCTURE, 400MM X 300MM X 150MM	EACH	4
UNIT DUCT, WITH 3-1/2 NO. 4 AND 1/2 NO. 6 GROUND, 600V (EPR-TYPE RHW), 30MM DIA. POLYETHYLENE	METER	150
ELECTRIC CABLE IN CONDUIT, 600V (EPR-TYPE RHW) 1/2 NO. 6	METER	56
ELECTRIC CABLE IN CONDUIT, 600V (EPR-TYPE RHW) 1/2 NO. 10	METER	483
ELECTRIC CABLE IN CONDUIT, 600V (EPR-TYPE RHW) 3-1/2 NO. 4	METER	56
TRENCH AND BACKFILL FOR ELECTRICAL WORK	METER	140
ELECTRIC CONNECTION TO SIGN STRUCTURE	EACH	2
UNDERPASS LUMINAIRE, 100 WATT, HIGH PRESSURE SODIUM VAPOR	EACH	8
MAINTENANCE OF LIGHTING SYSTEM	CAL MO	9

JUNCTION BOX SCHEDULE			
NO.	SIZE (MM)	DESCRIPTION	QUANTITY
JB1	400MM X 300MM X 150MM	STAINLESS STEEL, ATTACHED TO STRUCTURE	4
JB2	300MM X 250MM X 150MM	STAINLESS STEEL, ATTACHED TO STRUCTURE	4
JB3	150MM X 150MM X 100MM	STAINLESS STEEL, ATTACHED TO STRUCTURE	8

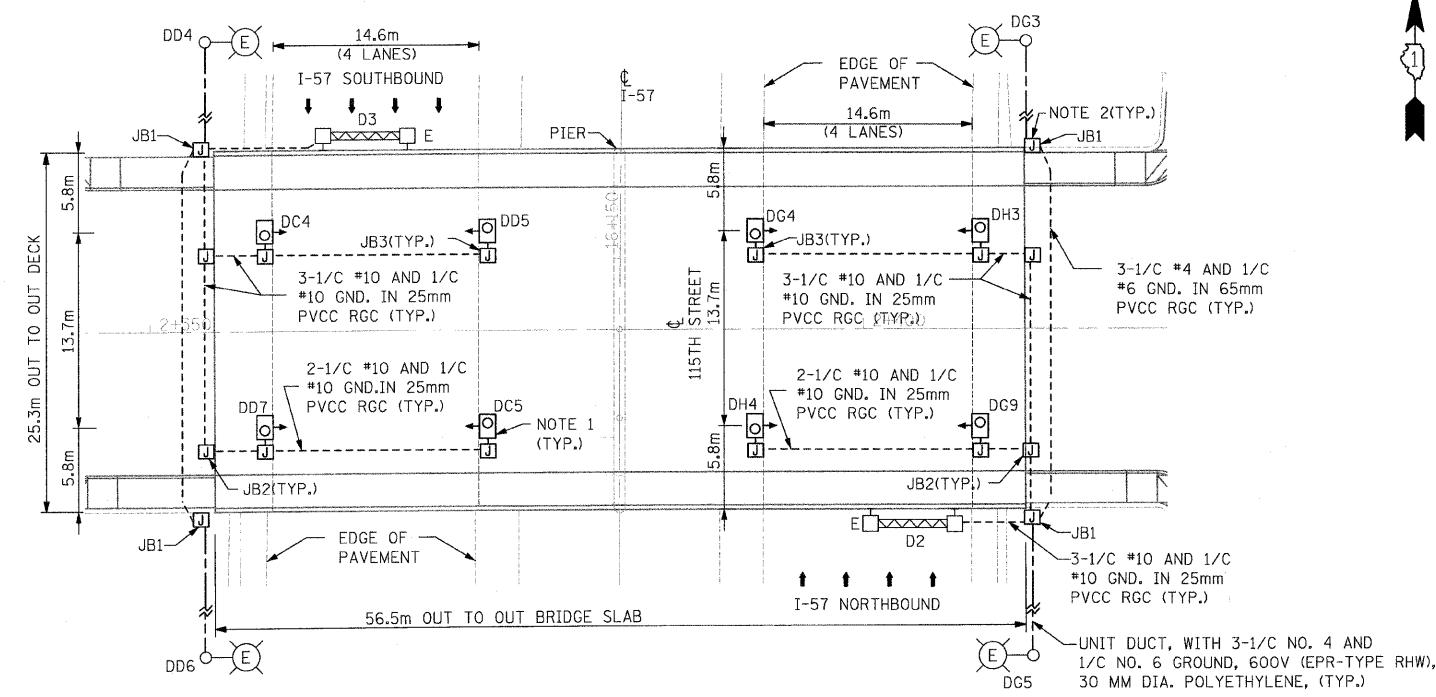

**PROPOSED UNDERPASS LIGHTING PLAN**

**CONSTRUCTION NOTES:**

- PROPOSED LUMINAIRES TO BE PENDANT MOUNTED, OFFSET 0.6m (2FT) FROM EDGE OF TRAVELED PAVEMENT. LUMINAIRES TO BE APPROXIMATELY CENTERED BETWEEN THE BEAMS.
- MOUNT JB1 1.5m ABOVE GRADE TO EXISTING ABUTMENT SIDE WALL. PROVIDE 65mm RSC RISER TO JUNCTION BOX TO ACCEPT NEW CABLE DUCT RUN FROM EXISTING LIGHT POLE TO REMAIN. SEE UNDERPASS LIGHTING DETAILS.
- CONTRACTOR SHALL MAKE ANY ADJUSTMENTS NECESSARY TO PROTECTIVE SHIELDING TO ACCOMMODATE INSTALLATION OF PROPOSED UNDERPASS LUMINAIRES. THIS WORK SHALL BE CONSIDERED INCIDENTAL TO "UNDERPASS LUMINAIRE, 100 WATT, HIGH PRESSURE SODIUM" PAY ITEM.

**REVISIONS**

NAME	DATE

ILLINOIS DEPARTMENT OF TRANSPORTATION  
115TH STREET OVER I-57  
PROPOSED UNDERPASS  
LIGHTING PLAN  
SCALE: 1:250  
DATE: 01-16-09  
DRAWN BY: BD  
CHECKED BY: RD

**SINGH** SINGH & ASSOCIATES, INC.  
CONSULTING ENGINEERS

F.A.I. RTE.	SECTION	COUNTY	TOTAL SHEETS	SHEET NO.
57	1919.2B	COOK	119	51
STA.		TO STA.		
FED. ROAD DIST. NO.		ILLINOIS FED. AID PROJECT		

CONTRACT #60371

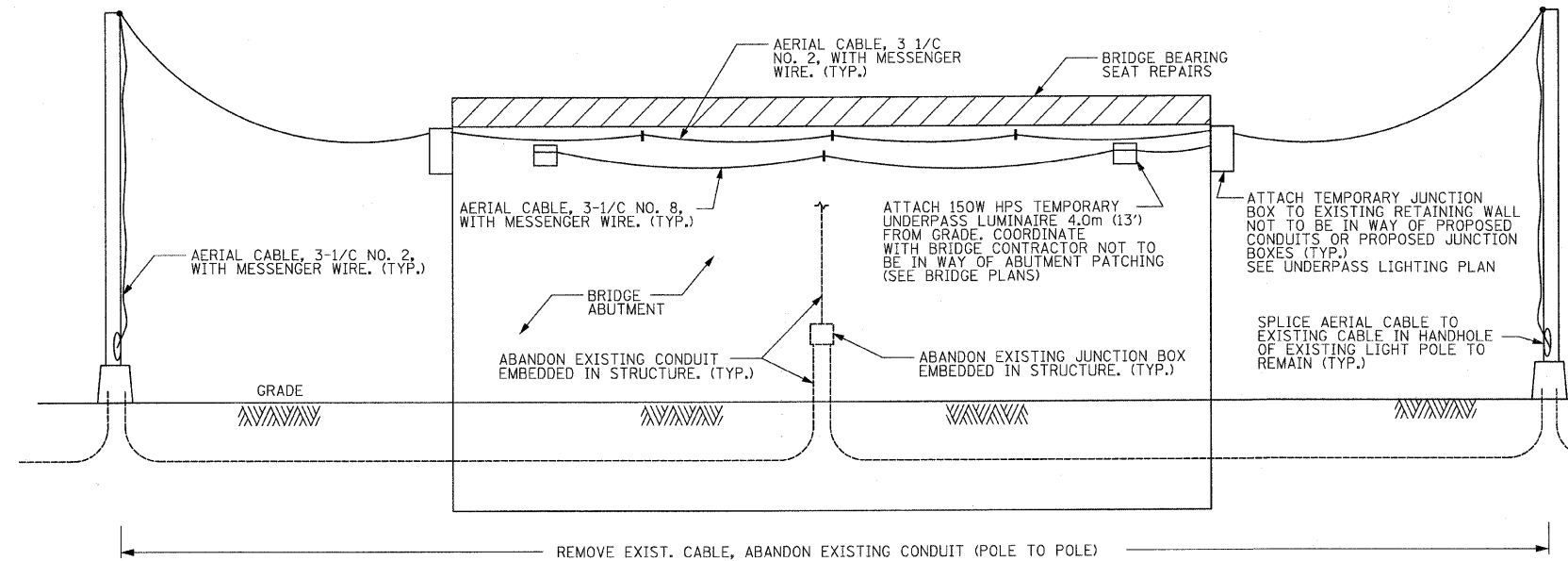

TEMPORARY UNDERPASS LIGHTING DETAIL (ELEVATION)

**CONSTRUCTION NOTES:**

1. SEE LIGHTING PLAN FOR LUMINAIRE SPACING.
2. CONTRACTOR SHALL COORDINATE WITH BRIDGE CONTRACTOR TO ESTABLISH MOUNTING HEIGHT OF LUMINAIRES TO ALLOW SUFFICIENT CLEARANCE FOR REPAIRS TO BRIDGE BEARING SEAT. CONTRACTOR SHALL NOT LOCATE TEMPORARY LUMINAIRES IN AREA OF SPALLED OR DELAMINATED CONCRETE AS SHOWN ON PLANS. SEE BRIDGE PLANS FOR DETAIL.
3. CONTRACTOR SHALL GROUT ANY HOLES IN "FINISHED" CONCRETE THAT WERE USED TO ATTACH TEMPORARY UNDERPASS LUMINAIRES. THIS WORK SHALL BE INCIDENTAL TO TEMPORARY UNDERPASS LIGHTING INSTALLATION AND REMOVAL.
4. ADDITIONAL WOOD POLES MAY BE NEEDED TO FACILITATE SPAN OF AERIAL WIRE.
5. INSTALLATION DETAILS FOR CENTER PIER MOUNTED LUMINAIRES ARE SIMILAR. SEE TEMPORARY UNDERPASS LIGHTING PLAN.
6. THE EXISTING LIGHTING CONTROLLER "D" POWERING THE UNDERPASS LUMINAIRES IS LOCATED ALONG I-57, NORTH EAST OF THE 115TH STREET BRIDGE.

REVISIONS	
NAME	DATE

ILLINOIS DEPARTMENT OF TRANSPORTATION  
115th STREET OVER I-57  
UNDERPASS LIGHTING DETAILS &  
SECTIONS 115TH STREET BRIDGE

SCALE: NTS  
DATE: 01-16-09

DRAWN BY: VG  
CHECKED BY: PV

**SINGH** SINGH & ASSOCIATES, INC.  
CONSULTING ENGINEERS

F.A.I. RTE.	SECTION	COUNTY	TOTAL SHEETS	SHEET NO.
57	1919.2B	COOK	119	52
STA.		TO STA.		
FED. ROAD DIST. NO.		ILLINOIS FED. AID PROJECT		

CONTRACT #60371

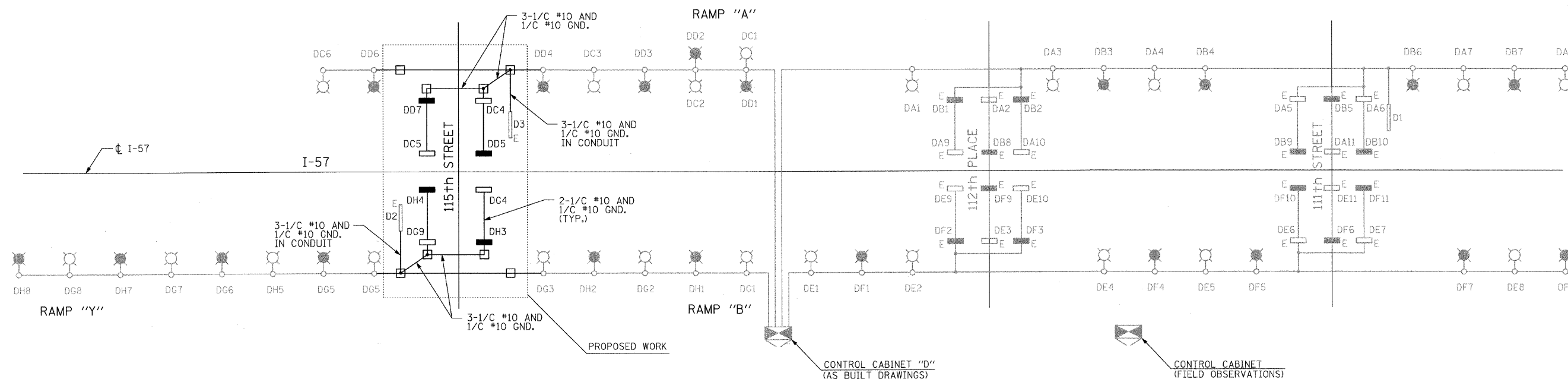
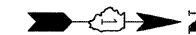

**LEGEND**

- EXISTING LUMINAIRE ON RED CABLE
- EXISTING LUMINAIRE ON BLACK CABLE
- EXISTING 55 WATT LPS, UNDERPASS LUMINAIRE ON RED CABLE
- EXISTING 55 WATT LPS, UNDERPASS LUMINAIRE ON BLACK CABLE
- PROPOSED 100 WATT HPS, UNDERPASS LUMINAIRE ON RED CABLE
- PROPOSED 100 WATT HPS, UNDERPASS LUMINAIRE ON BLACK CABLE
- EXISTING ILLUMINATED SIGN
- EXISTING LIGHTING CONTROLLER
- PROPOSED JUNCTION BOX ATTACHED TO STRUCTURE (SIZE PER PLANS)
- ELECTRIC CABLE, 3-1/C #4 AWG AND 1#6 GROUND IN UNIT DUCT UNLESS OTHERWISE NOTED

**NOTES:**

1. CONTRACTOR SHALL FIELD VERIFY ALL CIRCUITS, POLE NUMBERS AND WIRING.
2. CONTRACTOR SHALL FIELD VERIFY AND CORRECT CONTROLLER AND POLE LOCATIONS TO MATCH FIELD CONDITIONS. CONTRACTOR SHALL FIELD VERIFY CABLE AND CONDUIT CROSSINGS.
3. SHADED LINE WORK REPRESENTS EXISTING CONDITIONS.

REVISIONS		ILLINOIS DEPARTMENT OF TRANSPORTATION
NAME	DATE	
		115TH STREET OVER I-57 LIGHTING CONTROLLER "D" WIRING DIAGRAM

**SINGH** SINGH & ASSOCIATES, INC.  
CONSULTING ENGINEERS

SCALE: NONE  
DATE: 01-16-09

DRAWN BY: VG  
CHECKED BY: PV

W:\PROJECTS\1919.2B\1919.2B.DWG

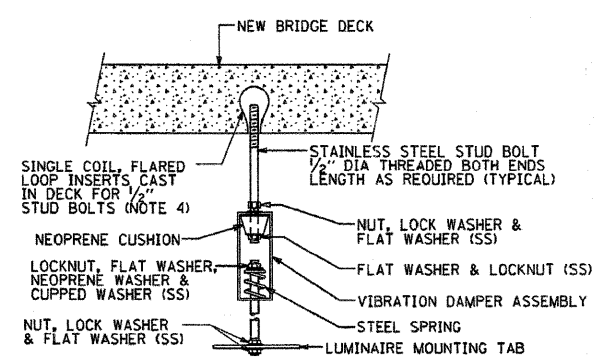
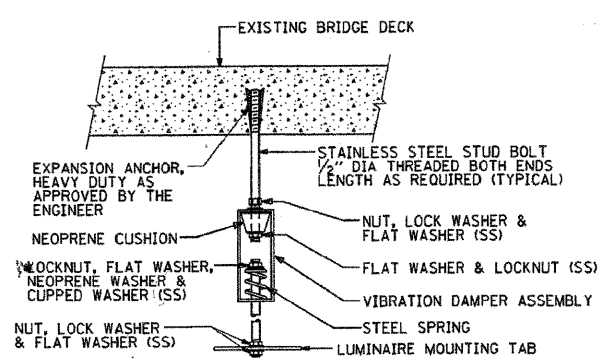
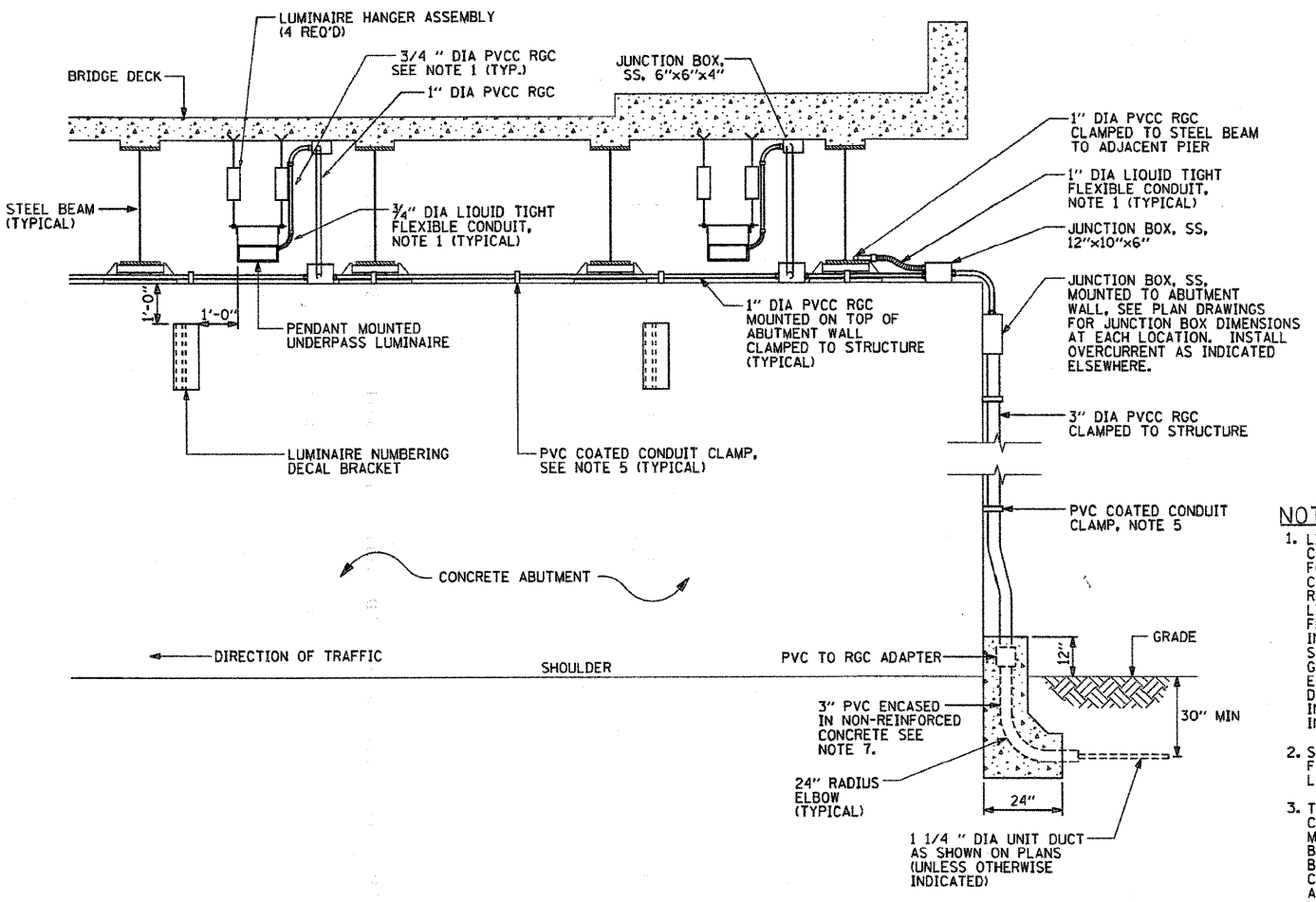
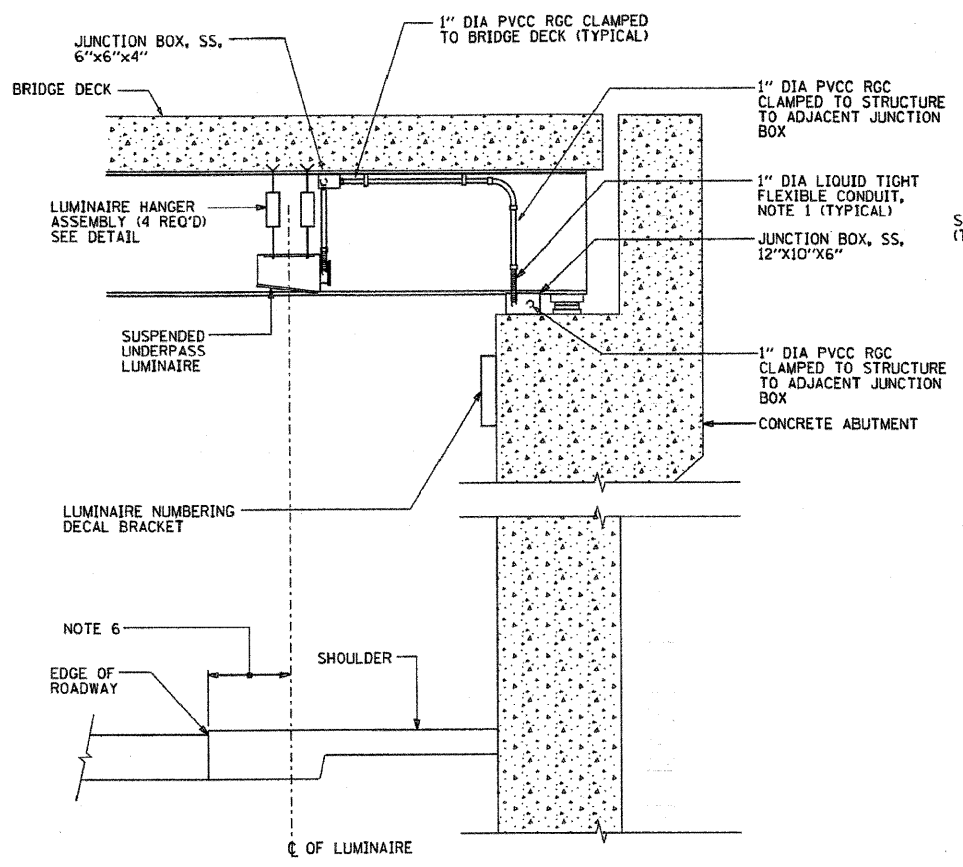

EXISTING BRIDGE DECK INSTALLATION

NEW BRIDGE DECK INSTALLATION

TYPICAL LUMINAIRE HANGER ASSEMBLY DETAILS

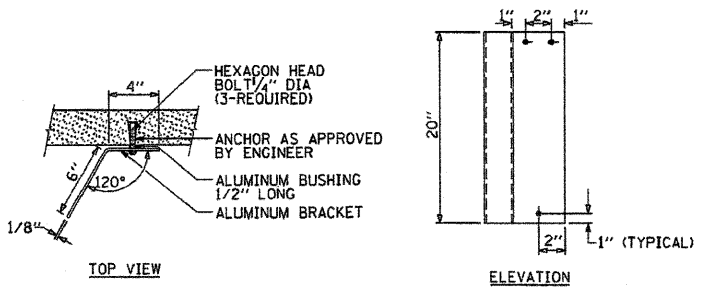

LUMINAIRE NUMBERING DECAL BRACKET NOT TO SCALE

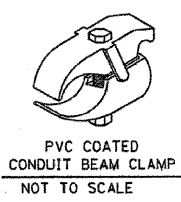

PVC COATED CONDUIT BEAM CLAMP NOT TO SCALE

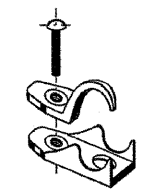

PVC COATED CONDUIT CLAMP NOT TO SCALE

\* IDOT STANDARD DRAWING IS PROVIDED IN ENGLISH UNITS.

**NOTES:**

- LIQUID TIGHT FLEXIBLE METAL CONDUIT, MAXIMUM LENGTH 6'-0", TYPICAL FOR EACH INSTANCE AS SHOWN, PROVIDE PVC COATED RIGID GALVANIZED STEEL CONDUIT AS REQUIRED NOT TO EXCEED 6'-0" OF FLEXIBLE LIQUID TIGHT METAL CONDUIT. LIQUID TIGHT FLEXIBLE METAL CONDUIT WILL BE INCLUDED IN THE COST OF THE CONDUIT ATTACHED TO STRUCTURE. OF THE CORRESPONDING DIA., GALVANIZED STEEL, PVC COATED PAY ITEM EXCEPT THAT 3/4" DIA. CONDUIT AND 3/4" DIA. FLEXIBLE CONDUIT SHALL BE INCLUDED IN THE COST OF UNDERPASS LUMINAIRE INSTALLATION.
- SEE UNDERPASS LIGHTING PLANS FOR INSTALLATION LOCATION OF UNDERPASS LIGHTING LUMINAIRES.
- THE CONTRACTOR SHALL USE APPROVED SINGLE COIL FLARED LOOP INSERTS WHEN SUSPENDED MOUNTING AN UNDERPASS LUMINAIRE TO A NEW BRIDGE DECK. THE FLARED LOOP INSERTS MUST BE CAST INTO THE CONCRETE DECK. THE CONTRACTOR IS RESPONSIBLE FOR LOCATING AND COORDINATING THE INSERT LOCATIONS FOR MOUNTING THE UNDERPASS LIGHTING SYSTEM AS SHOWN ON THE PLANS WITH THE BRIDGE DECK CONTRACTOR. SEE DETAIL.
- THE UNDERPASS LUMINAIRE HANGER ASSEMBLY COMPLETE WITH HEAVY DUTY ANCHORS/INSERTS AND ALL APPLICABLE HARDWARE SHALL BE INCLUDED IN THE COST OF THE UNDERPASS LUMINAIRE PAY ITEM.
- SECURE THE CONDUIT WITH PVC COATED CONDUIT CLAMPS OR CONDUIT BEAM CLAMPS AS SHOWN AT 5'-0" INTERVALS FOR LATERALS AND WITHIN 2'-0" MAXIMUM FROM ANY JUNCTION BOX, FLEXIBLE CONDUIT, OR CHANGE IN DIRECTION. ALL PVC COATED CONDUIT CLAMPS OR BEAM CLAMPS SHALL BE INCLUDED WITH THE COST OF THE "CONDUIT ATTACHED TO STRUCTURE, OF THE CORRESPONDING DIA., GALVANIZED STEEL, PVC COATED" PAY ITEM.
- ALL UNDERPASS LUMINAIRES MUST BE CENTERED IN THE BEAM SPACE AS INDICATED ON THE PLANS UNLESS OTHERWISE DIRECTED BY THE ENGR. LUMINAIRE SETBACK SHALL BE AS INDICATED IN PLANS FOR EACH SPECIFIC UNDERPASS.
- THE CONCRETE ENCASED CONDUIT TRANSITION SHALL BE INCLUDED IN THE COST OF THE GALVANIZED RIGID STEEL CONDUIT PAY ITEMS.
- ALL CONDUIT ATTACHED TO STRUCTURE SHALL BE PVC COATED RIGID STEEL CONDUIT (PVCC RGC) TYPICAL.

REVISIONS	
NAME	DATE

ILLINOIS DEPARTMENT OF TRANSPORTATION

**SUSPENDED MOUNT UNDERPASS LUMINAIRE INSTALLATION DETAILS**

SCALE: NONE      DRAWN BY:

DATE: JANUARY, 2005      CHECKED BY:

**SINGH** SINGH & ASSOCIATES, INC. CONSULTING ENGINEERS

CONTRACT NO.				
F.A.I. RTE.	SECTION	COUNTY	TOTAL SHEETS	SHEET NO.
57	1919.2B	COOK	119	54
STA.		TO STA.		
FED. ROAD DIST. NO.		ILLINOIS FED. AID PROJECT		

CONTRACT #60371

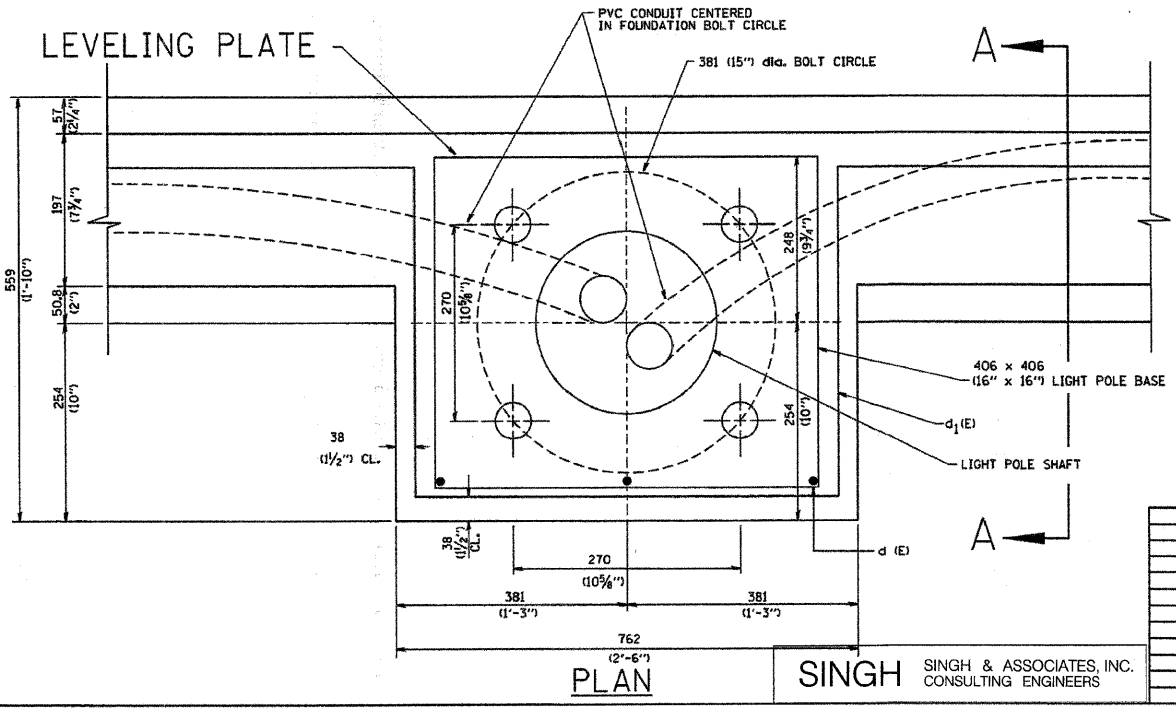
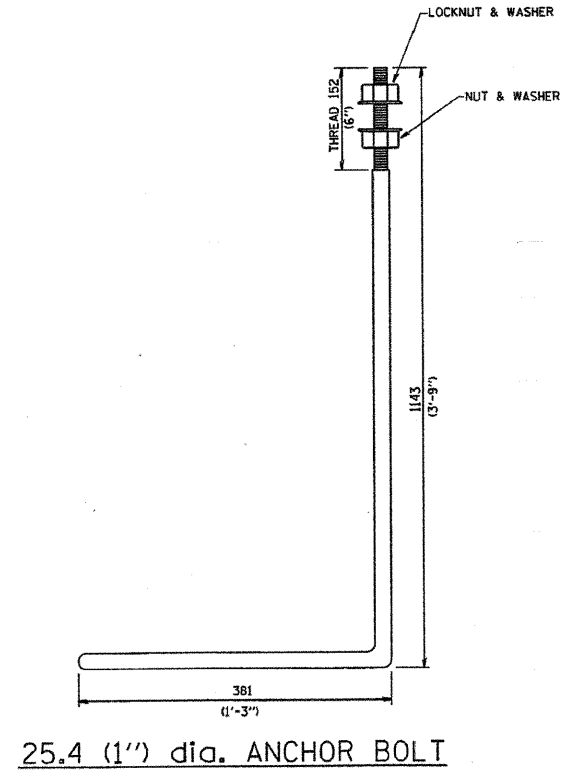
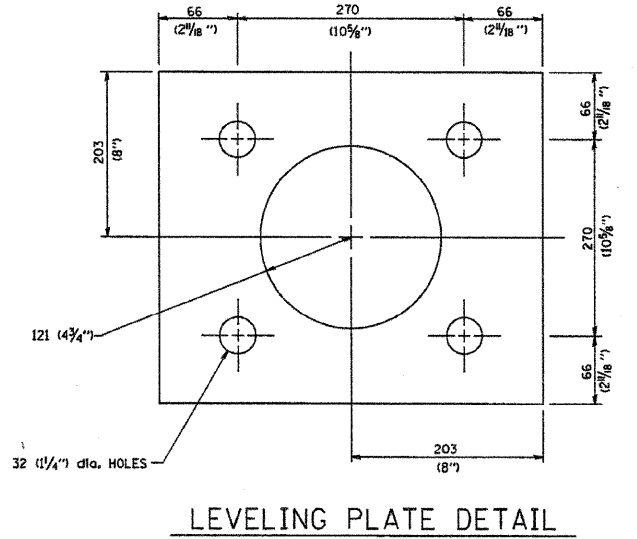
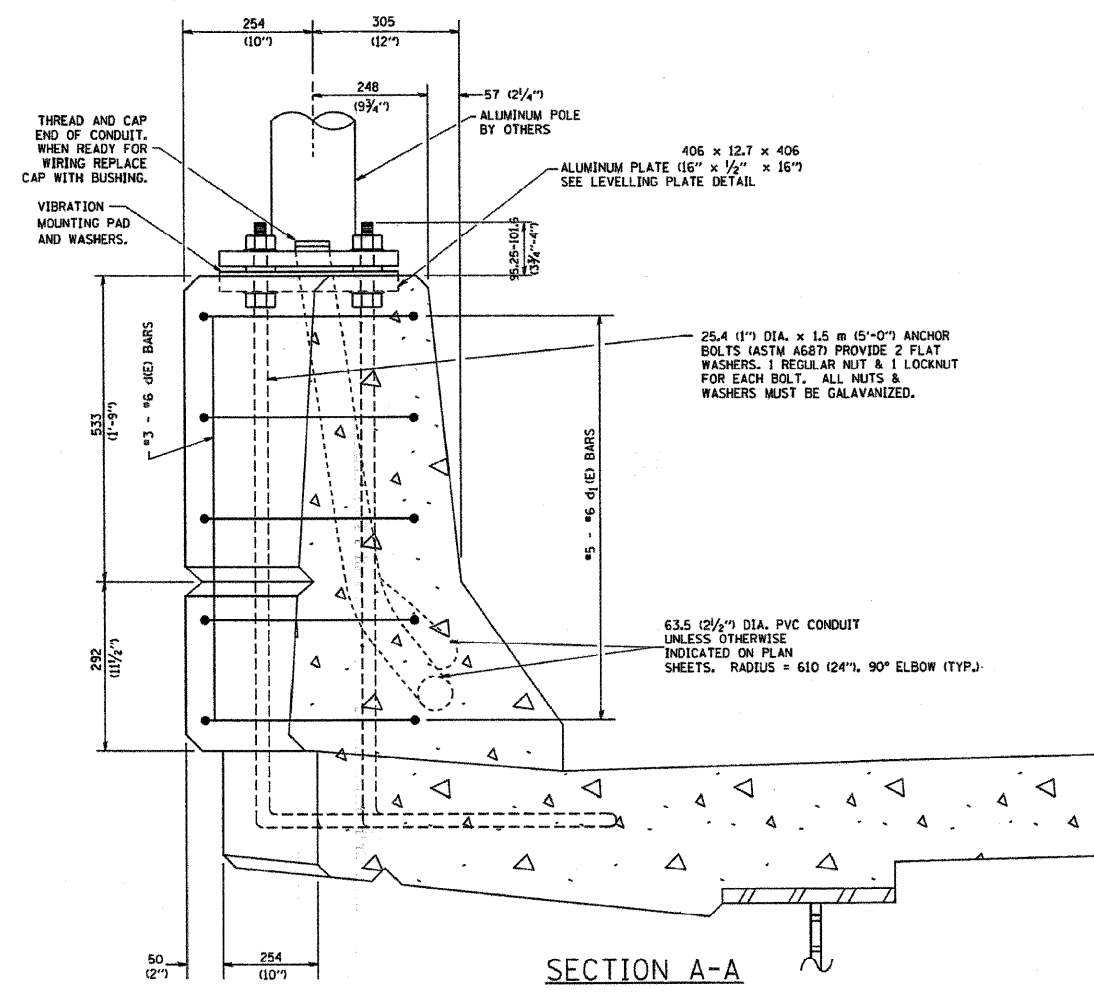
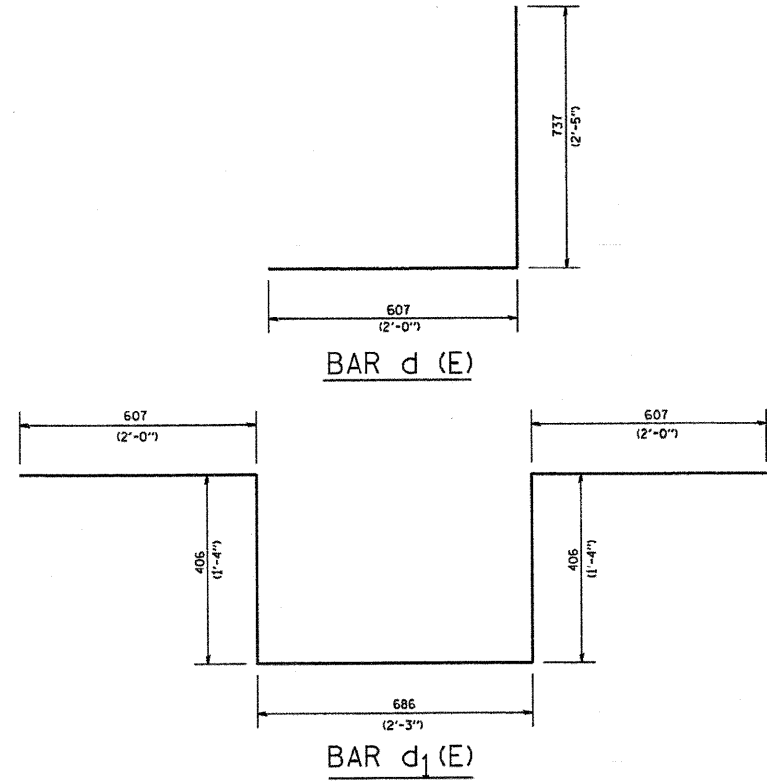

- NOTES**
1. ALL DIMENSIONS ARE IN MILLIMETERS (INCHES) UNLESS OTHERWISE SHOWN.
  2. LEVEL LIGHT POLE PLATES, USING THE FLANGE NUTS, PRIOR TO POURING THE PARAPET WALL. THE TOP OF THE PLATE SHALL BE AT THE SAME ELEVATION AS THE FINISHED CONCRETE PARAPET.
  3. THE COST OF ANCHOR BOLTS, CONDUIT, LEVELLING PLATE AND FOUNDATION IS INCLUDED IN THE COST OF THE BRIDGE STRUCTURE.
  4. ANCHOR BOLTS SHALL BE 25mm (1") DIA., BOLT CIRCLE SHALL BE 292mm (11 1/2") DIA., EMBEDDED PVC CONDUIT SHALL BE 50mm (2") DIA.
  5. THIS DETAIL IS INCLUDED TO DEMONSTRATE INTENT OF INSTALLATION ONLY. SEE STRUCTURAL PLANS FOR DETAILED CONFIGURATION.

PLOT DATE = 2/15/2006  
 PLOT SCALE = 40:0000 / IN.  
 USER NAME = gajjarabdt

REVISIONS	
NAME	DATE

ILLINOIS DEPARTMENT OF TRANSPORTATION  
**LIGHT POLE MOUNTED ON CONCRETE PARAPET WALL**  
**381 mm (15") BOLT CIRCLE**

SCALE: NONE  
 DATE: 2/15/2006

DRAWN BY  
 CHECKED BY  
 BE-330

**SINGH** SINGH & ASSOCIATES, INC.  
 CONSULTING ENGINEERS

REVISION DATE: 04/22/02

F.A.I. RTE.	SECTION	COUNTY	TOTAL SHEETS	SHEET NO.
57	1919.2B	COOK	119	55
STA.		TO STA.		
FED. ROAD DIST. NO.		ILLINOIS FED. AID PROJECT		

CONTRACT #60371

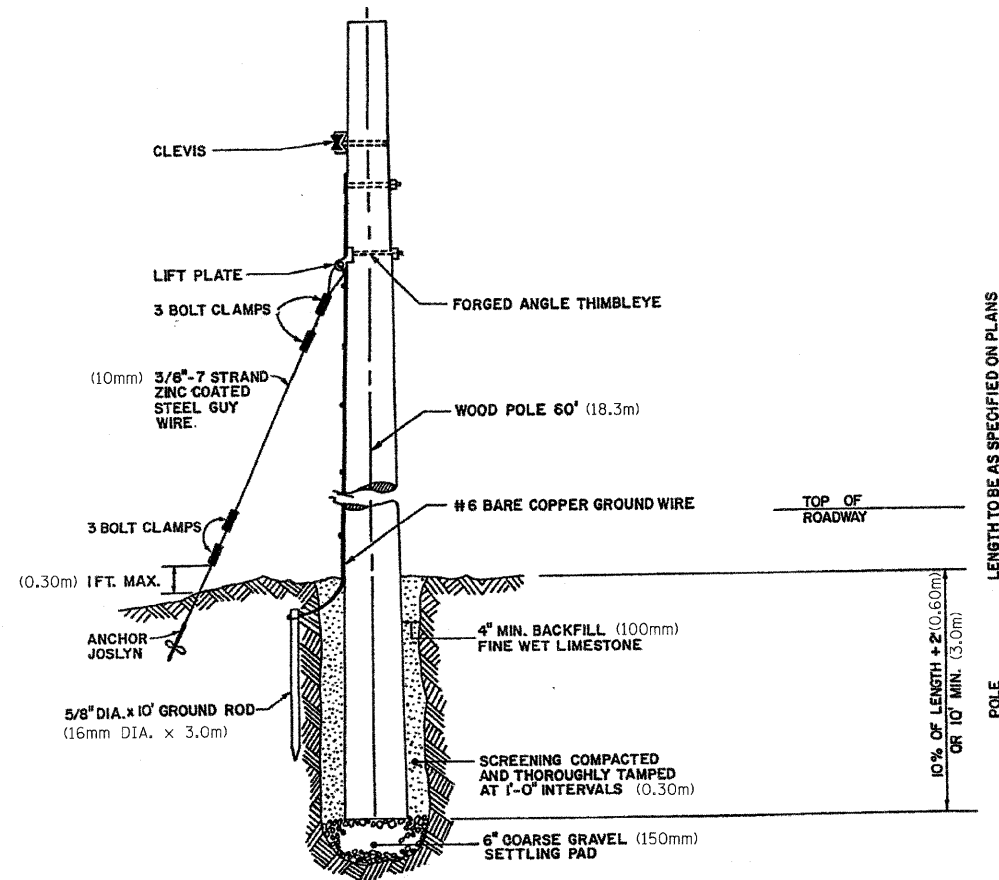

**TEMPORARY POLE DETAIL**

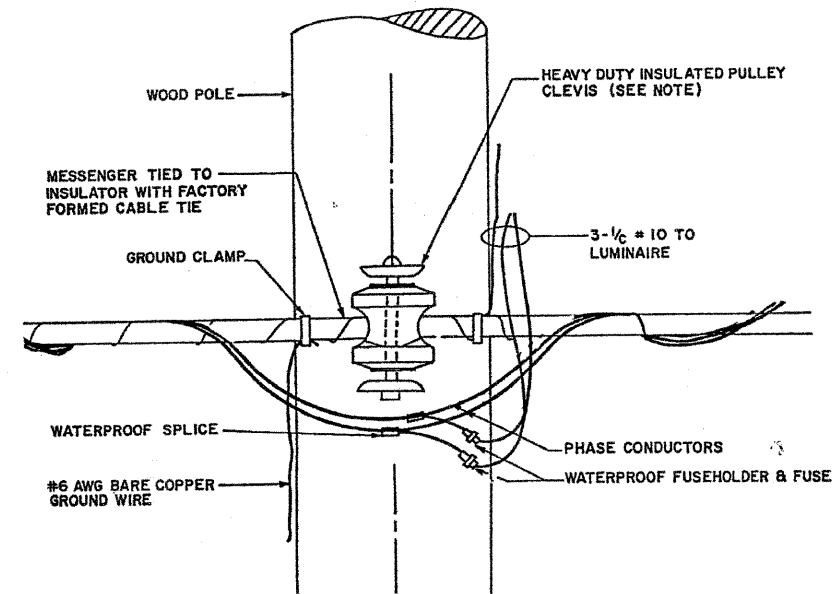

**TEMPORARY POLE CABLE ATTACHMENT DETAIL**

NOTE:  
 WITH THE APPROVAL OF THE ENGINEER, A SECONDARY CABLE SPREADER SECURED TO THE POLE MAY BE USED IN CONJUNCTION WITH THE QUADRUPLIX IN LIEU OF THE HEAVY DUTY INSULATED PULLEY CLEVIS

REVISIONS		ILLINOIS DEPARTMENT OF TRANSPORTATION 115th STREET OVER I-57 TEMPORARY POLE DETAIL AND CABLE ATTACHMENT DETAIL
NAME	DATE	

**SINGH** SINGH & ASSOCIATES, INC.  
CONSULTING ENGINEERS

SCALE: NTS  
DATE: 01-16-09  
DRAWN BY: BD  
CHECKED BY: RD

F.A.I. RTE.	SECTION	COUNTY	TOTAL SHEETS	SHEET NO.
57	1919.2B	COOK	119	56
STA.		TO STA.		
FED. ROAD DIST. NO.		ILLINOIS FED. AID PROJECT		

CONTRACT #60371

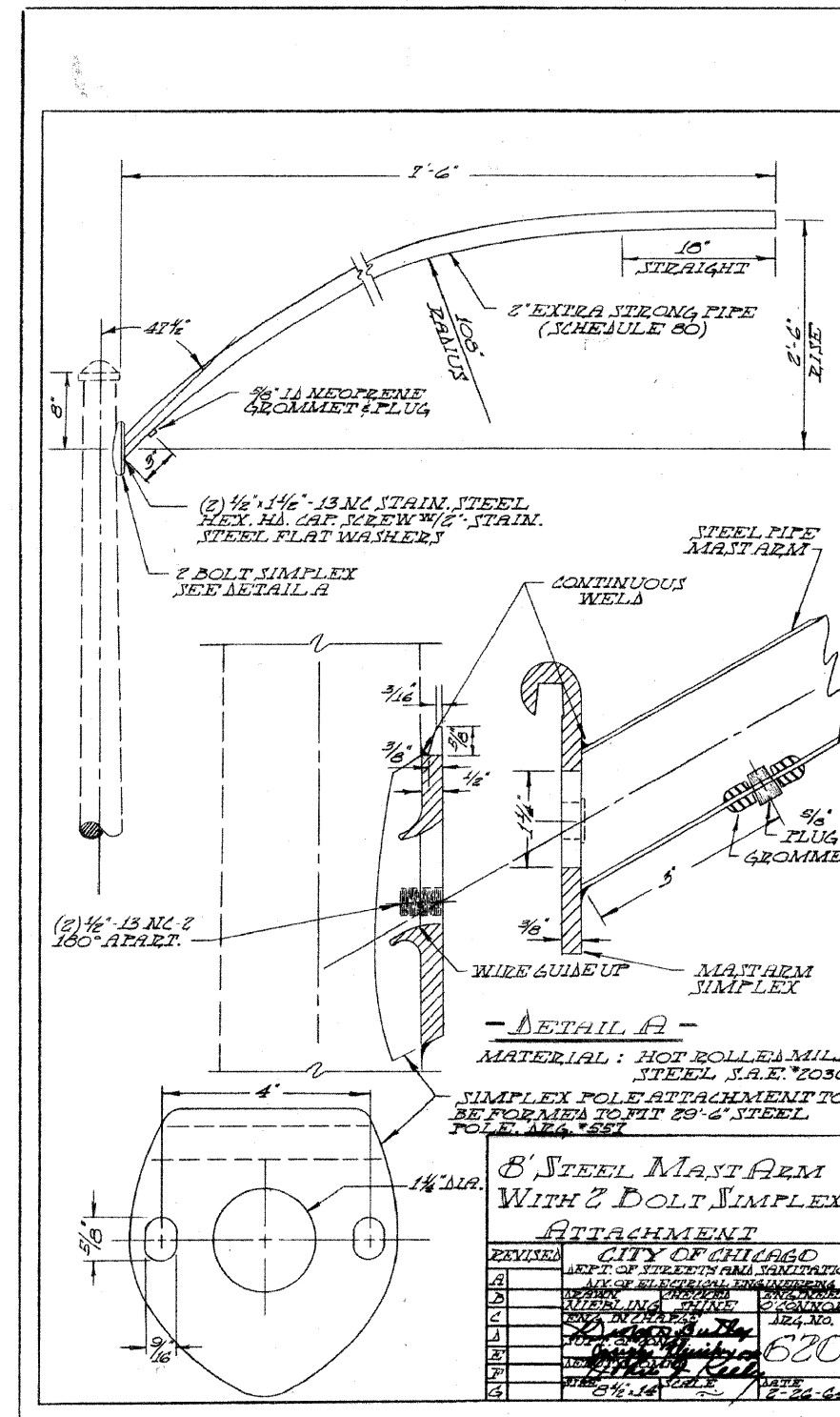
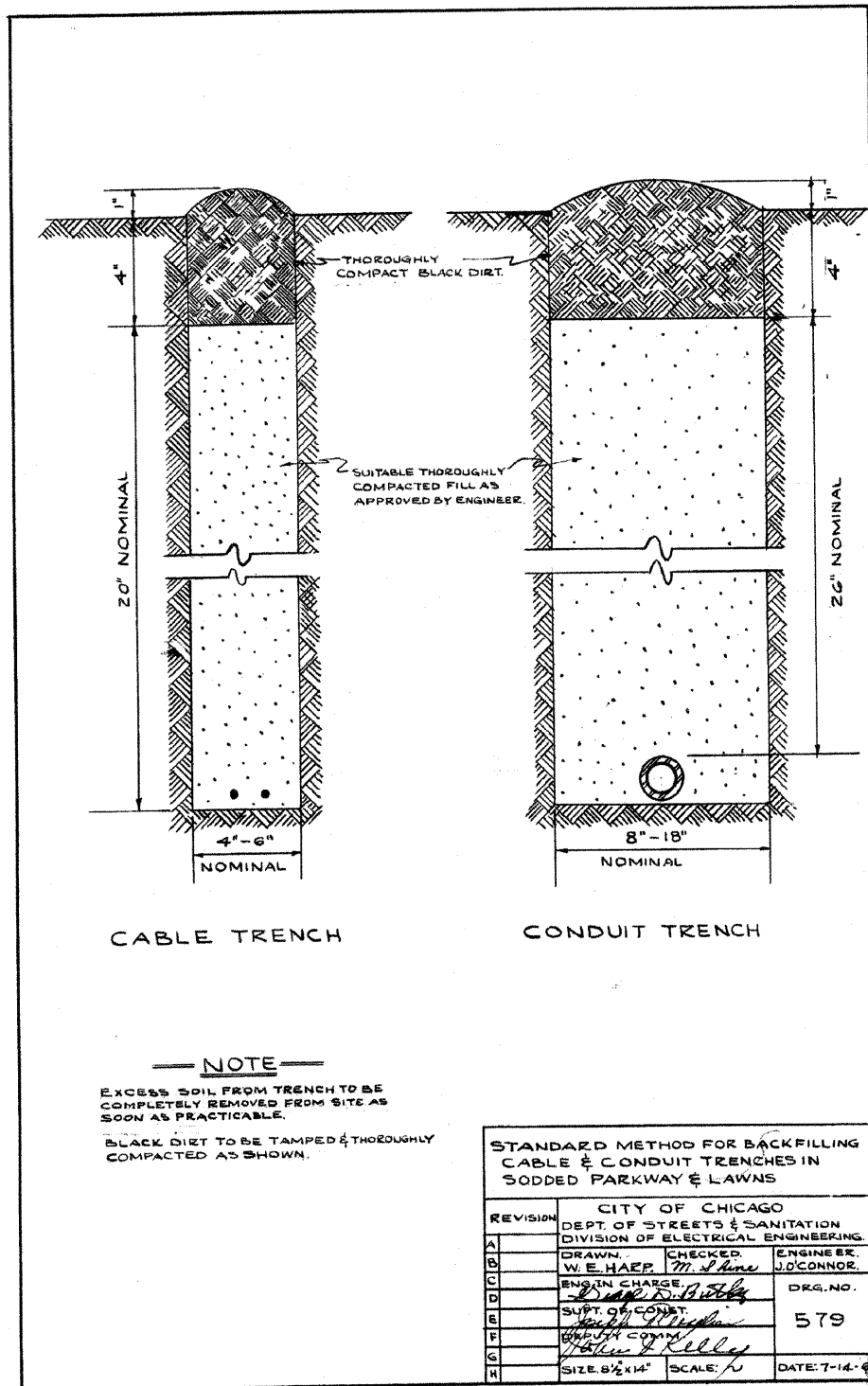

CITY OF CHICAGO BUREAU OF ELECTRICITY  
 STANDARD DRAWINGS ARE PROVIDED IN ENGLISH UNITS.

**SINGH** SINGH & ASSOCIATES, INC.  
 CONSULTING ENGINEERS

REVISIONS	
NAME	DATE

ILLINOIS DEPARTMENT OF TRANSPORTATION  
 115TH STREET OVER I-57  
 CITY OF CHICAGO  
 BUREAU OF ELECTRICITY  
 STANDARD DRAWINGS

SCALE: NONE  
 DATE: 01-16-09  
 DRAWN BY: VG  
 CHECKED BY: PV





F.A.I. RTE.	SECTION	COUNTY	TOTAL SHEETS	SHEET NO.
57	1919.2B	COOK	119	58
STA.		TO STA.		
FED. ROAD DIST. NO.		ILLINOIS FED. AID PROJECT		

CONTRACT #60371

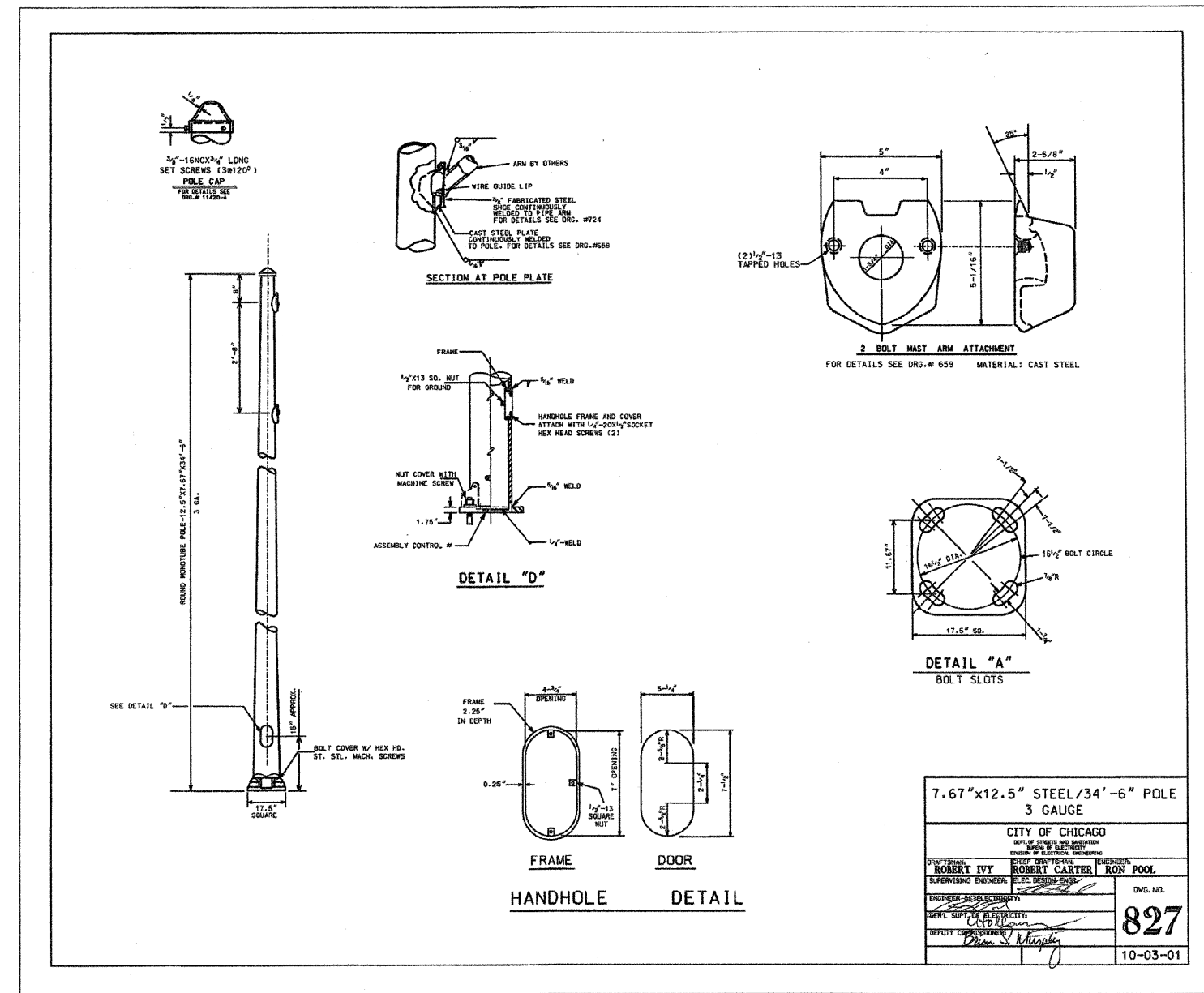
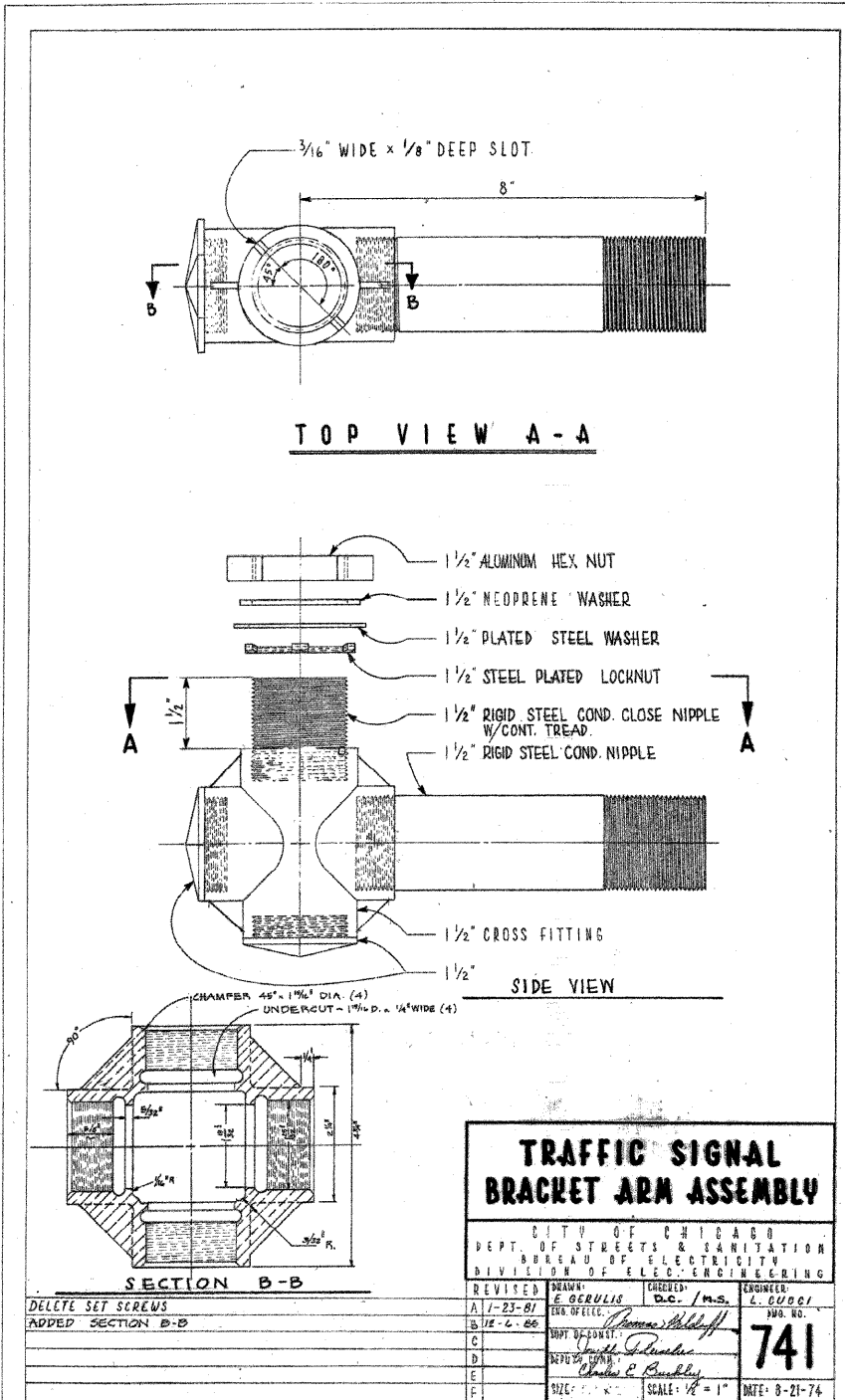

\* CITY OF CHICAGO BUREAU OF ELECTRICITY  
STANDARD DRAWINGS ARE PROVIDED IN ENGLISH  
UNITS.

SINGH SINGH & ASSOCIATES, INC.  
CONSULTING ENGINEERS

REVISIONS		ILLINOIS DEPARTMENT OF TRANSPORTATION 115TH STREET OVER I-57 CITY OF CHICAGO BUREAU OF ELECTRICITY STANDARD DRAWINGS
NAME	DATE	
		SCALE: NONE DATE: 01-16-09 DRAWN BY: VG CHECKED BY: PV

F.A.I. RTE.	SECTION	COUNTY	TOTAL SHEETS	SHEET NO.
57	1919.2B	COOK	119	59
STA.		TO STA.		
FED. ROAD DIST. NO.		ILLINOIS FED. AID PROJECT		

CONTRACT #60371

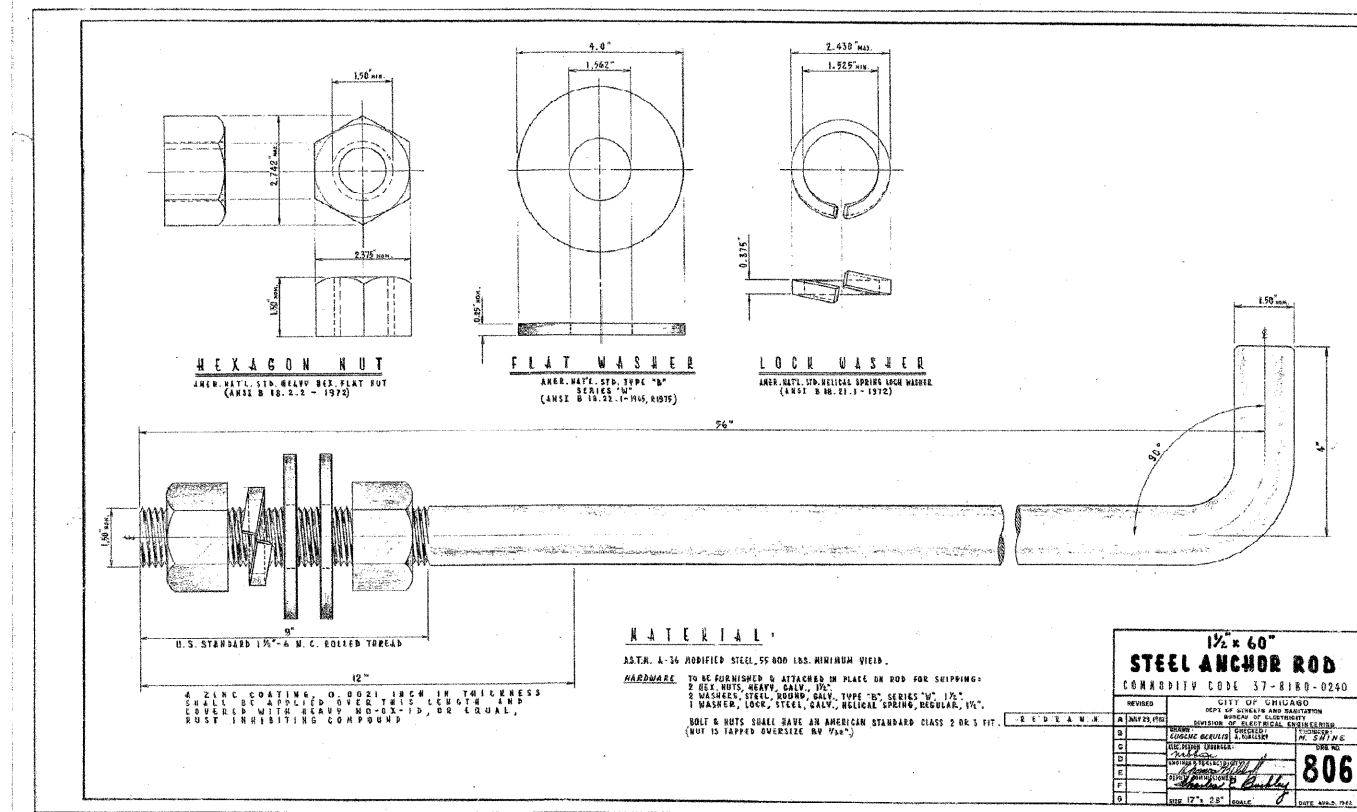
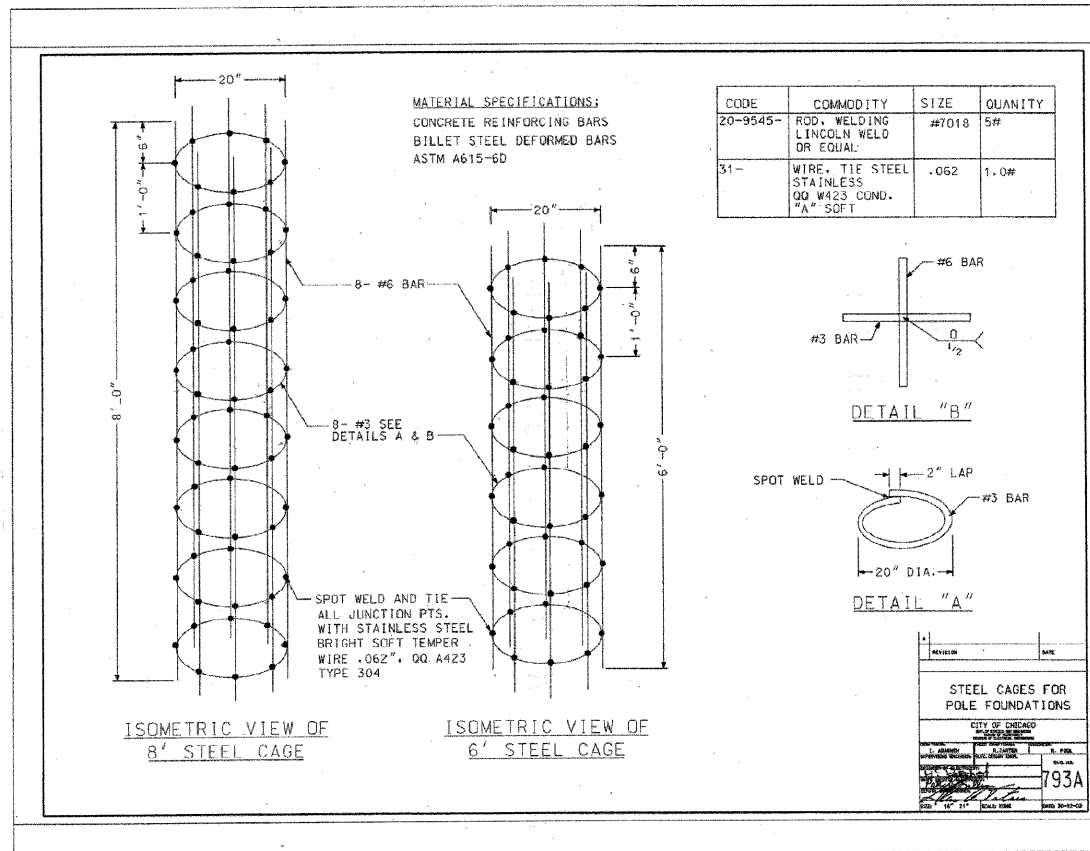

\* CITY OF CHICAGO BUREAU OF ELECTRICITY  
 STANDARD DRAWINGS ARE PROVIDED IN ENGLISH  
 UNITS.

REVISIONS		ILLINOIS DEPARTMENT OF TRANSPORTATION 115TH STREET OVER I-57 CITY OF CHICAGO BUREAU OF ELECTRICITY STANDARD DRAWINGS	
NAME	DATE		
		SCALE: NONE DATE: 01-16-09	
			DRAWN BY: VG CHECKED BY: PV

**SINGH** SINGH & ASSOCIATES, INC.  
 CONSULTING ENGINEERS

F.A.I. RTE.	SECTION	COUNTY	TOTAL SHEETS	SHEET NO.
57	1919.2B	COOK	119	60
STA.	TO STA.			
FED. ROAD DIST. NO.	ILLINOIS	FED. AID PROJECT		

CONTRACT #60371

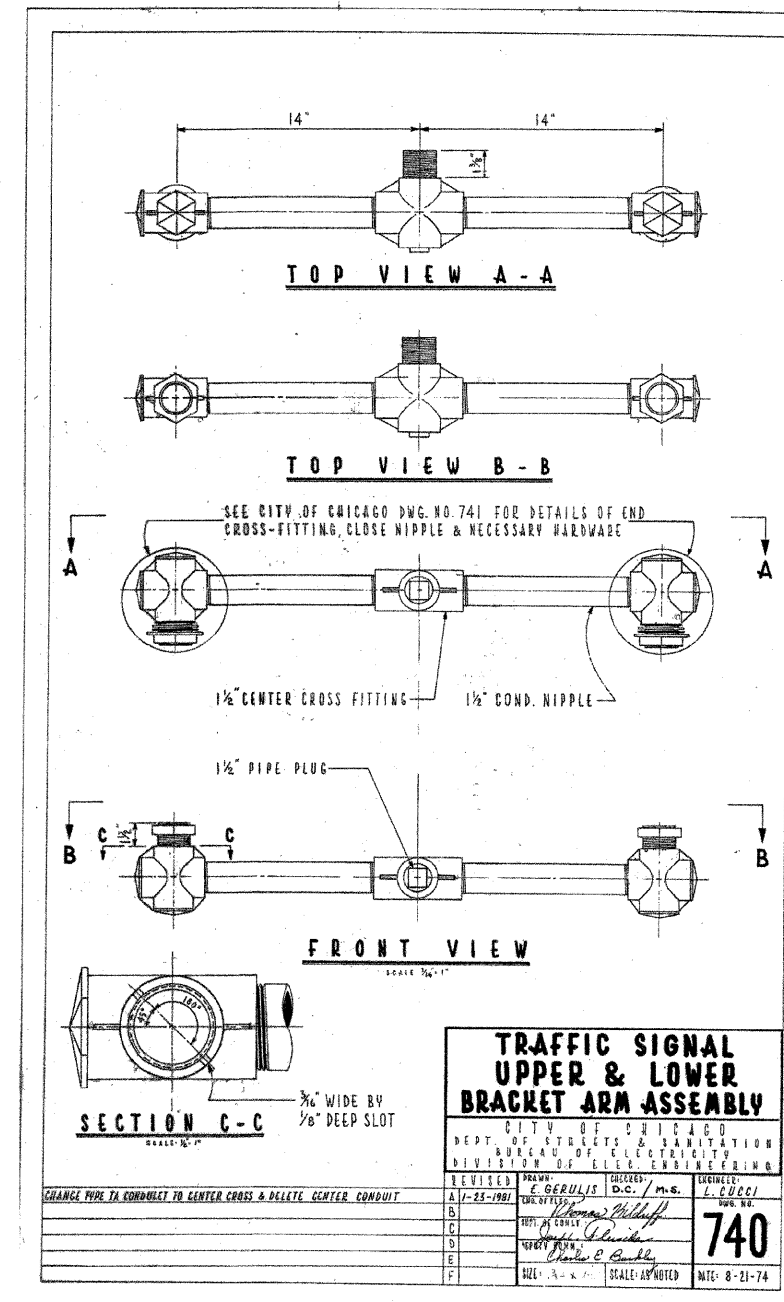
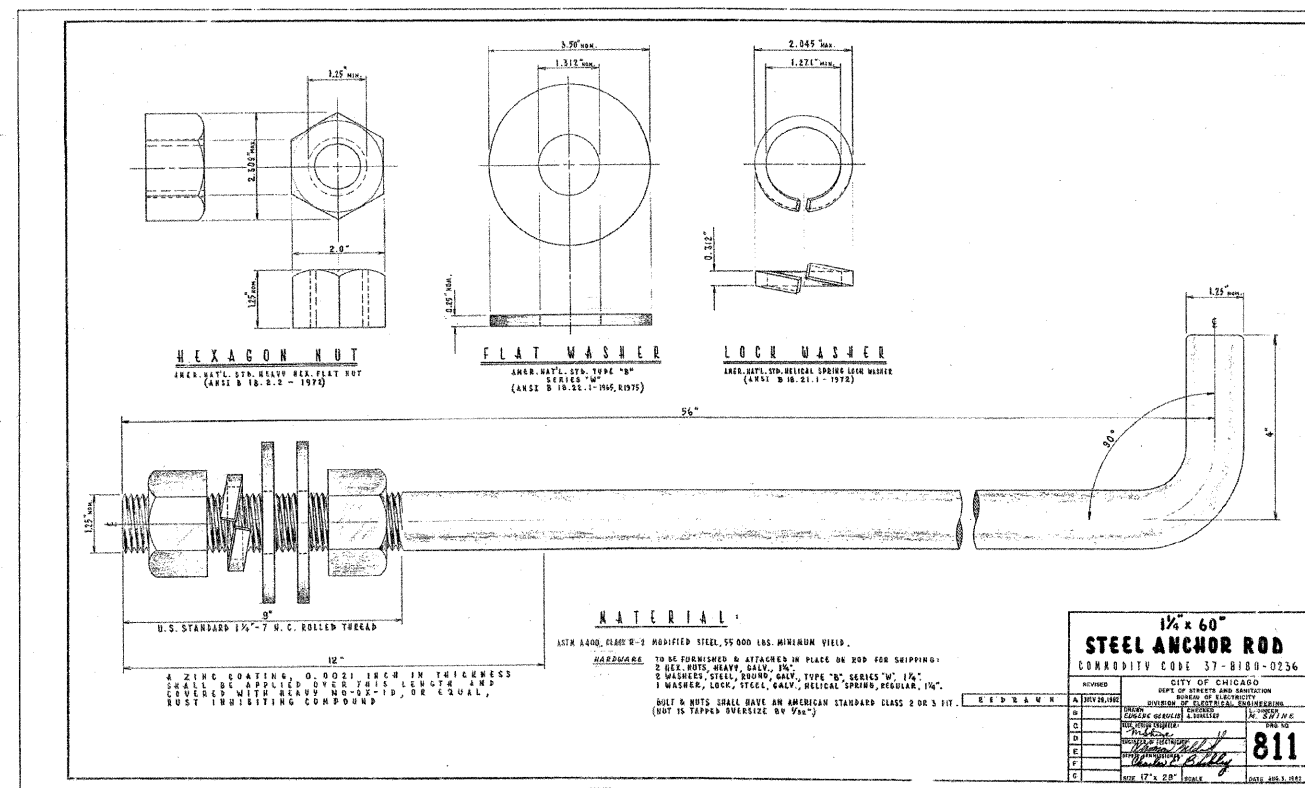

\* CITY OF CHICAGO BUREAU OF ELECTRICITY STANDARD DRAWINGS ARE PROVIDED IN ENGLISH UNITS.

SINGH SINGH & ASSOCIATES, INC. CONSULTING ENGINEERS

REVISIONS	NAME	DATE	ILLINOIS DEPARTMENT OF TRANSPORTATION
			115TH STREET OVER I-57
			CITY OF CHICAGO
			BUREAU OF ELECTRICITY
			STANDARD DRAWINGS
			SCALE: NONE
			DRAWN BY: VG
			CHECKED BY: PV
			DATE: 01-16-09

F.A.I. RTE.	SECTION	COUNTY	TOTAL SHEETS	SHEET NO.
57	1919.2B	COOK	119	61
STA.		TO STA.		
FED. ROAD DIST. NO.		ILLINOIS FED. AID PROJECT		

CONTRACT #60371

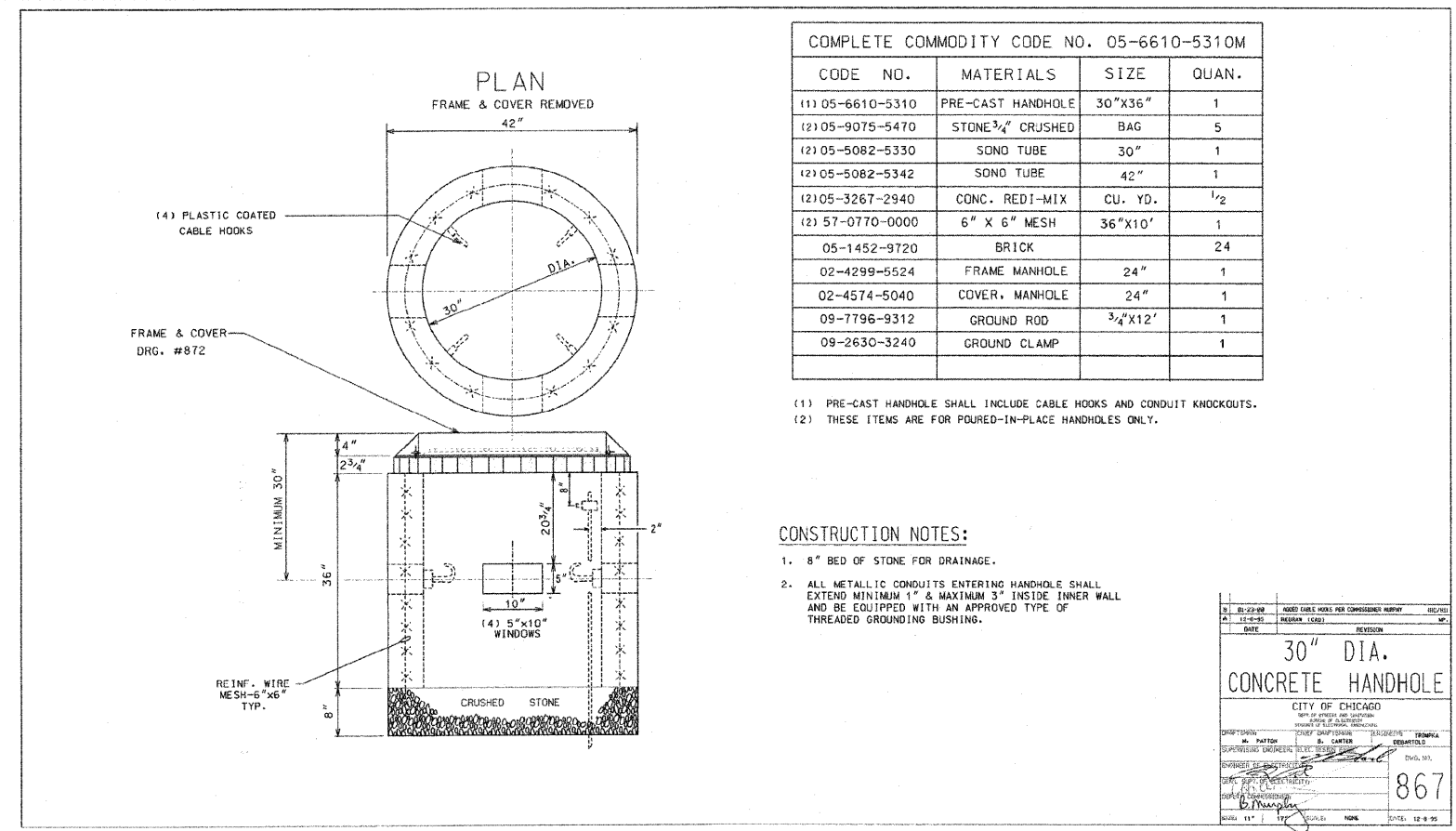
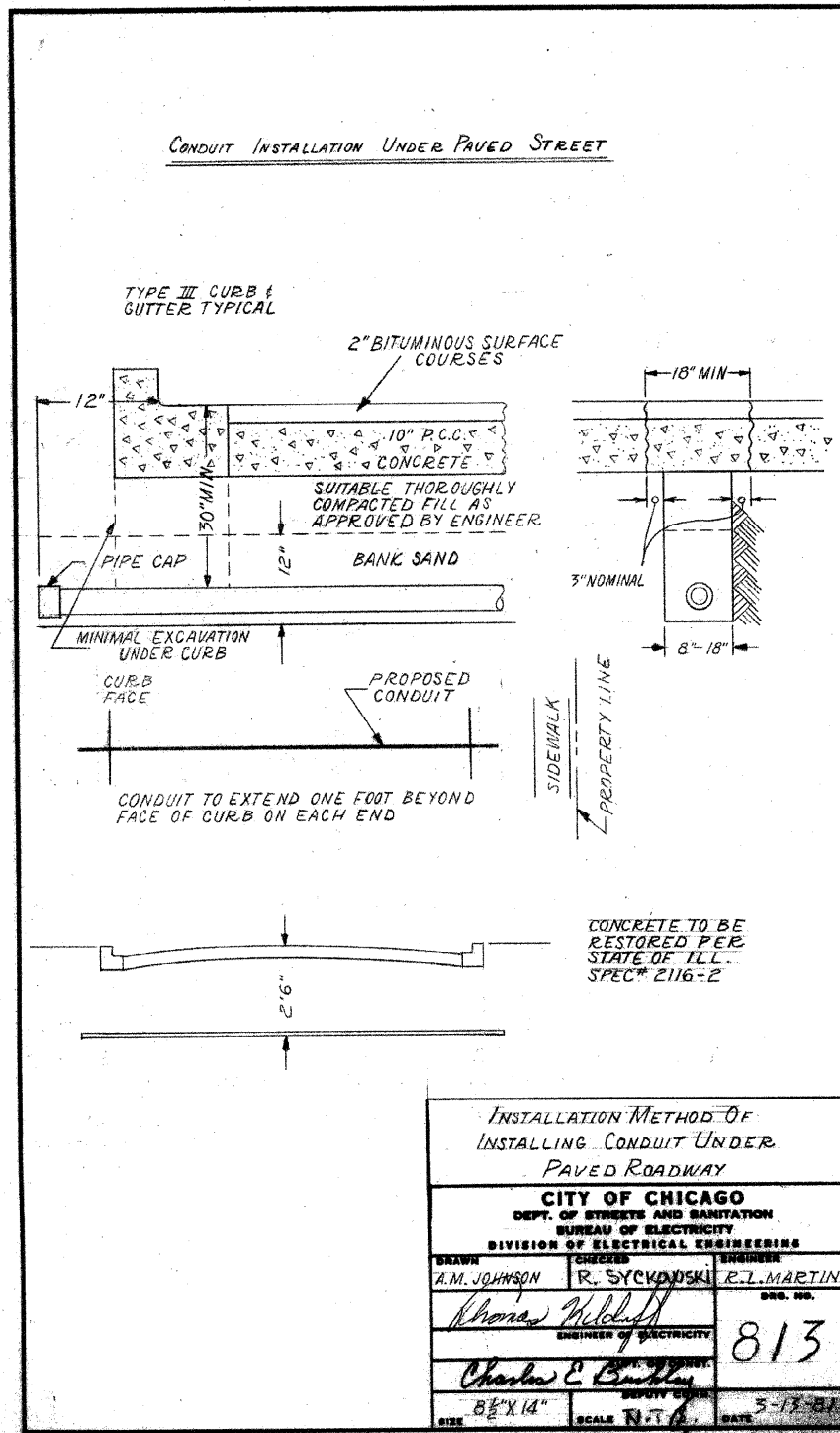

CITY OF CHICAGO BUREAU OF ELECTRICITY  
STANDARD DRAWINGS ARE PROVIDED IN ENGLISH  
UNITS.

**SINGH** SINGH & ASSOCIATES, INC.  
CONSULTING ENGINEERS

REVISIONS	
NAME	DATE

ILLINOIS DEPARTMENT OF TRANSPORTATION  
115TH STREET OVER I-57  
CITY OF CHICAGO  
BUREAU OF ELECTRICITY  
STANDARD DRAWINGS

SCALE: NONE  
DATE: 01-16-09

DRAWN BY: VG  
CHECKED BY: PV

F.A.I. RTE.	SECTION	COUNTY	TOTAL SHEETS NO.
57	1919.2B	COOK	119 62
STA.	TO STA.		
FED. ROAD DIST. NO.	ILLINOIS	FED. AID PROJECT	

CONTRACT #60371

CONDUIT INSTALLATION THROUGH EXISTING MANHOLE OR HANDHOLE WALL

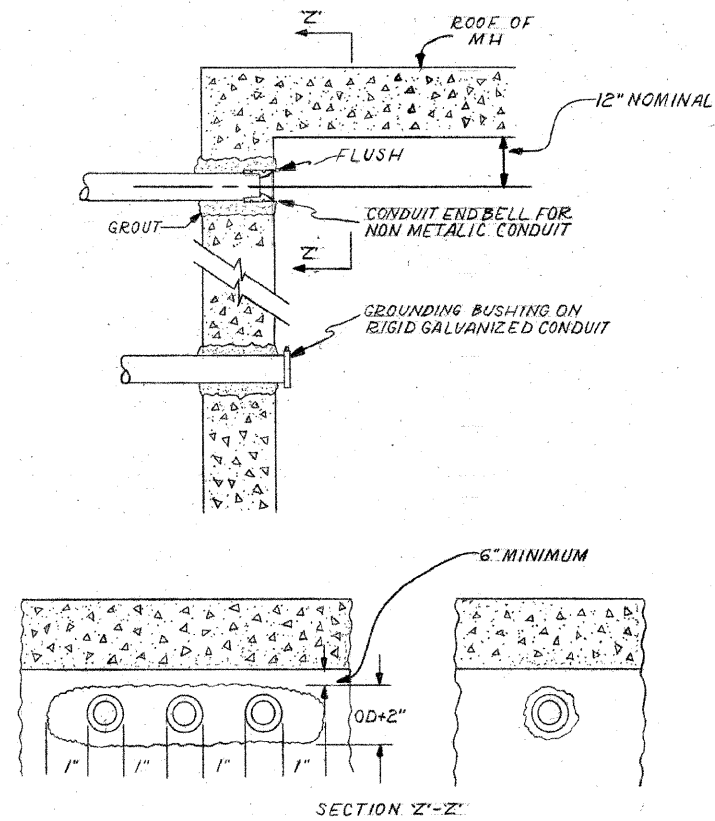

OPENING THROUGH WALL TO BE KEPT TO MINIMUM SIZE TO ADMIT CONDUIT AND SUFFICIENT GROUT TO ASSURE SEALING WALL.

INSTALLATION METHOD OF INSTALLING CONDUIT THRU MANHOLE WALL		
CITY OF CHICAGO DEPT. OF STREETS AND SANITATION BUREAU OF ELECTRICITY DIVISION OF ELECTRICAL ENGINEERING		
DRAWN A.M. JOHANSON	CHECKED R. SYCKOWSKI	ENGINEER R.L. MARTIN
ENGINEER OF ELECTRICITY <i>Charles E. Buntley</i>		DRG. NO. 814
SIZE 8 1/2" X 14"	SCALE N.T.S.	DATE 5-12-91

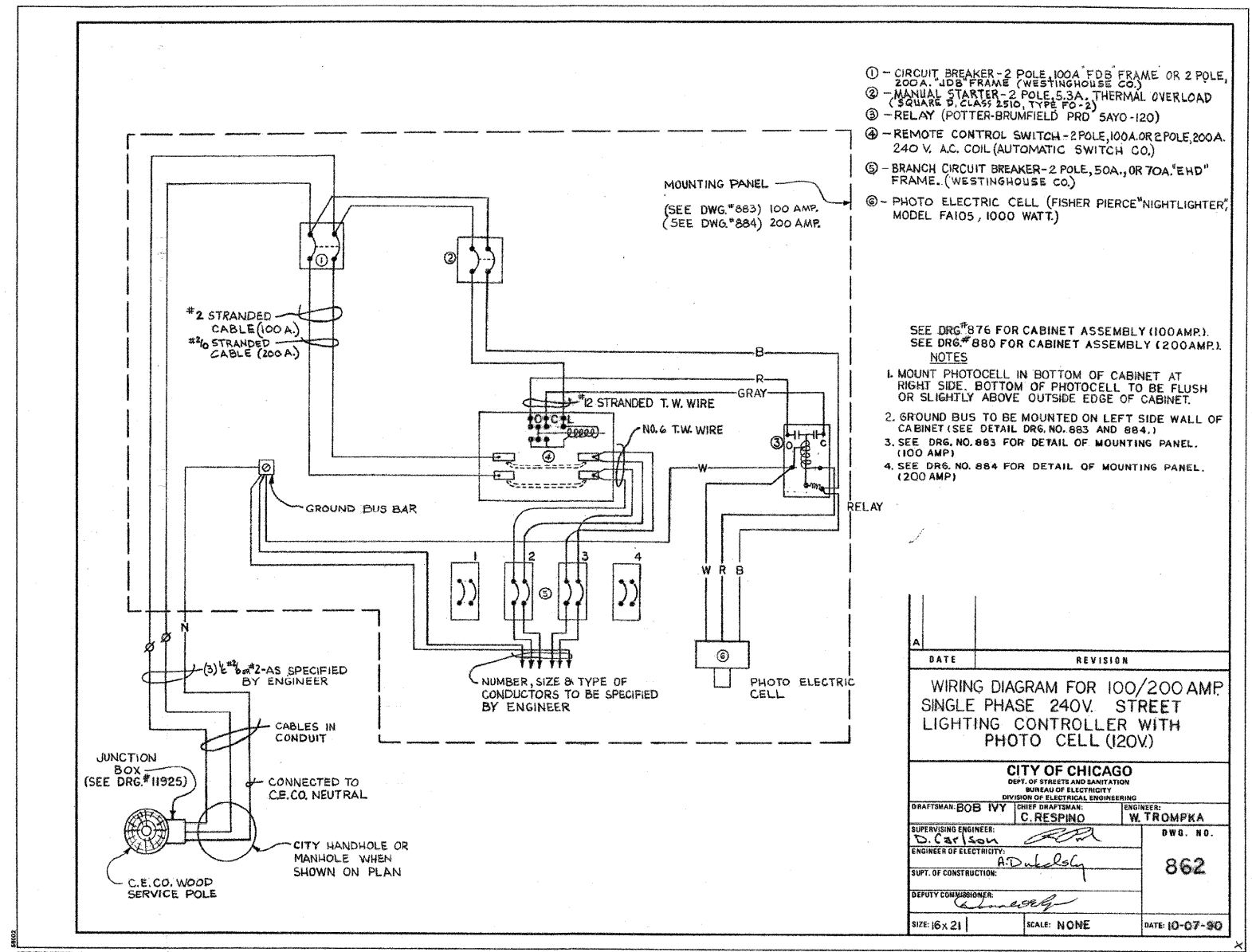

- ① - CIRCUIT BREAKER - 2 POLE, 100A "EHD" FRAME OR 2 POLE, 200A "JDB" FRAME (WESTINGHOUSE CO.)
- ② - MANUAL STARTER - 2 POLE, 5, 3A, THERMAL OVERLOAD (SQUARE D, CLASS 2510, TYPE FC-2)
- ③ - RELAY (POTTER-BRUMFIELD PRO SAYO-120)
- ④ - REMOTE CONTROL SWITCH - 2 POLE, 100A OR 2 POLE, 200A, 240 V. A.C. COIL (AUTOMATIC SWITCH CO.)
- ⑤ - BRANCH CIRCUIT BREAKER - 2 POLE, 50A, OR 70A "EHD" FRAME. (WESTINGHOUSE CO.)
- ⑥ - PHOTO ELECTRIC CELL (FISHER PIERCE "NIGHTLIGHTER", MODEL FA105, 1000 WATT.)

SEE DRG.#876 FOR CABINET ASSEMBLY (100AMP).  
SEE DRG.#880 FOR CABINET ASSEMBLY (200AMP).  
NOTES

- 1. MOUNT PHOTOCELL IN BOTTOM OF CABINET AT RIGHT SIDE. BOTTOM OF PHOTOCELL TO BE FLUSH OR SLIGHTLY ABOVE OUTSIDE EDGE OF CABINET.
- 2. GROUND BUS TO BE MOUNTED ON LEFT SIDE WALL OF CABINET (SEE DETAIL DRG. NO. 883 AND 884.)
- 3. SEE DRG. NO. 883 FOR DETAIL OF MOUNTING PANEL. (100 AMP)
- 4. SEE DRG. NO. 884 FOR DETAIL OF MOUNTING PANEL. (200 AMP)

DATE	REVISION

WIRING DIAGRAM FOR 100/200 AMP SINGLE PHASE 240V. STREET LIGHTING CONTROLLER WITH PHOTO CELL (120V.)

CITY OF CHICAGO DEPT. OF STREETS AND SANITATION BUREAU OF ELECTRICITY DIVISION OF ELECTRICAL ENGINEERING		
DRAFTSMAN: BOB IVY	CHIEF DRAFTSMAN: C. RESPINO	ENGINEER: W. TROMPKA
SUPERVISING ENGINEER: D. Carlson	DWG. NO. 862	
ENGINEER OF ELECTRICITY: A. Dubelsky		
SUPT. OF CONSTRUCTION:		
DEPUTY COMMISSIONER:		
SIZE: 16x 21	SCALE: NONE	DATE: 10-07-90

CITY OF CHICAGO BUREAU OF ELECTRICITY STANDARD DRAWINGS ARE PROVIDED IN ENGLISH UNITS.

REVISIONS	
NAME	DATE

ILLINOIS DEPARTMENT OF TRANSPORTATION  
115TH STREET OVER I-57  
CITY OF CHICAGO  
BUREAU OF ELECTRICITY  
STANDARD DRAWINGS

SCALE: NONE  
DATE: 01-16-09

DRAWN BY: VG  
CHECKED BY: PV

SINGH SINGH & ASSOCIATES, INC.  
CONSULTING ENGINEERS

F.A.I. RTE.	SECTION	COUNTY	TOTAL SHEETS	SHEET NO.
57	1919.2B	COOK	119	63
STA.		TO STA.		
FED. ROAD DIST. NO.		ILLINOIS FED. AID PROJECT		

CONTRACT #60371

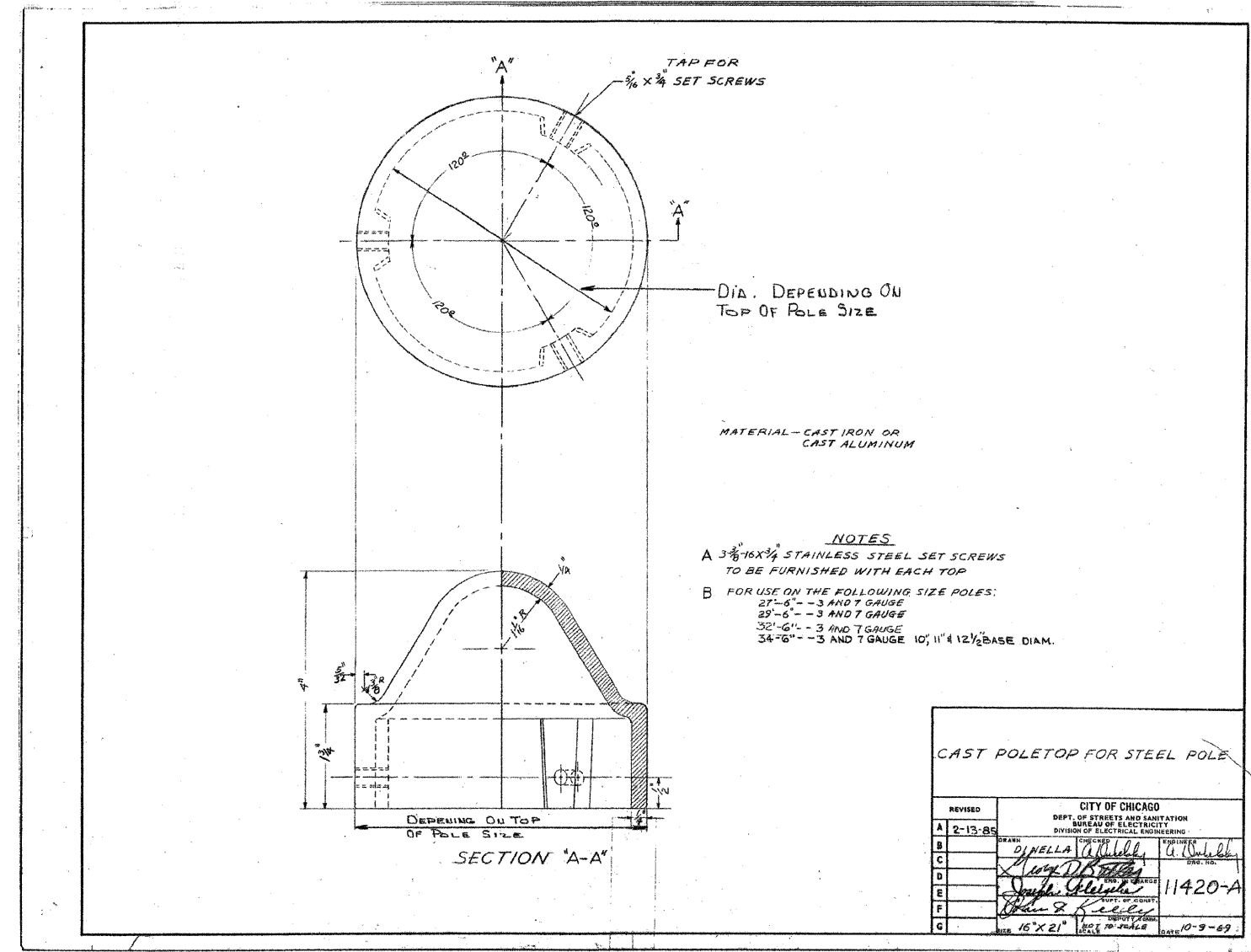
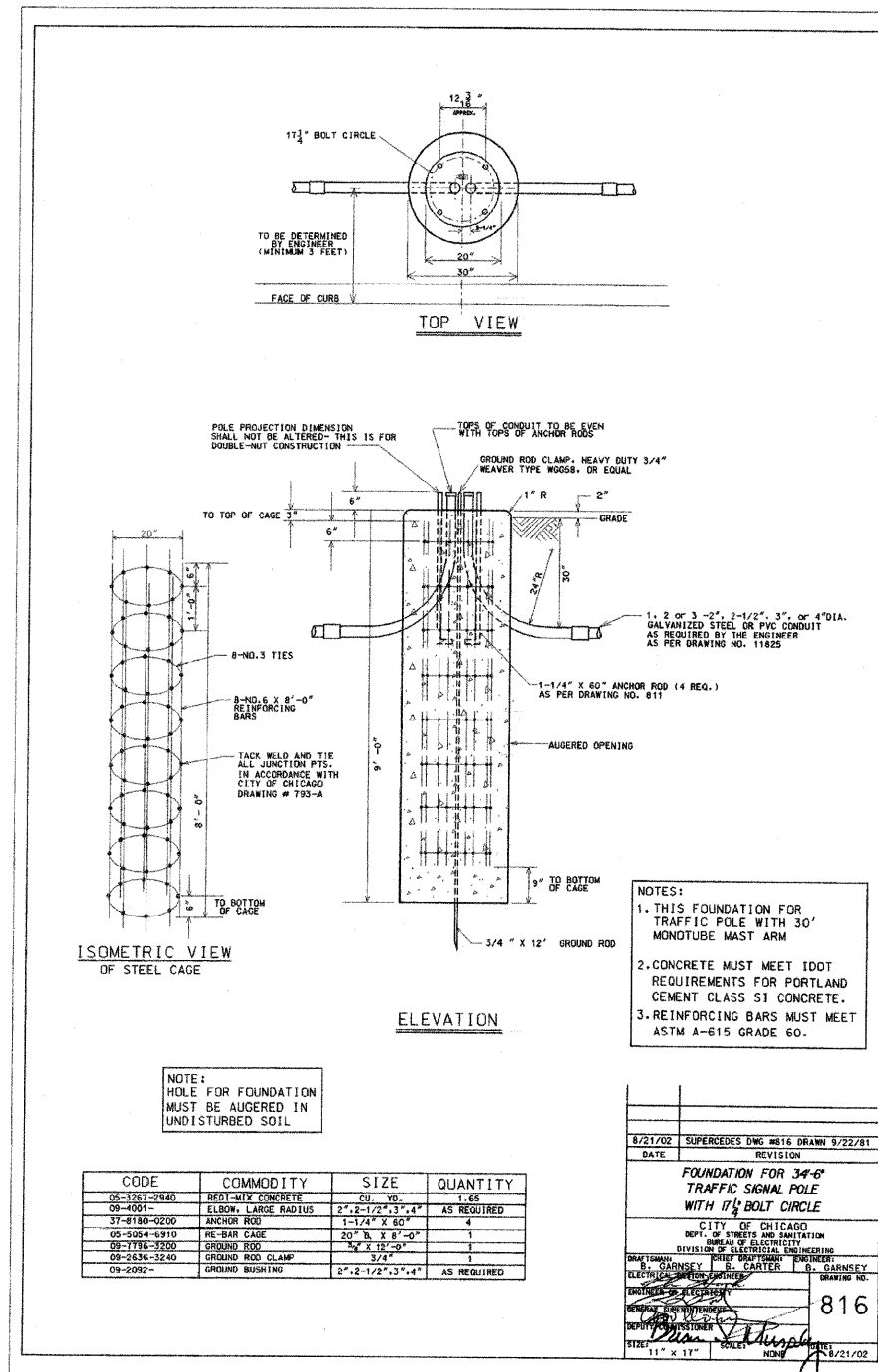

\* CITY OF CHICAGO BUREAU OF ELECTRICITY STANDARD DRAWINGS ARE PROVIDED IN ENGLISH UNITS.

SINGH SINGH & ASSOCIATES, INC.  
CONSULTING ENGINEERS

REVISIONS		ILLINOIS DEPARTMENT OF TRANSPORTATION 115TH STREET OVER I-57 CITY OF CHICAGO BUREAU OF ELECTRICITY STANDARD DRAWINGS
NAME	DATE	
		SCALE: NONE DATE: 01-16-09 DRAWN BY: VG CHECKED BY: PV

F.A.I. RTE.	SECTION	COUNTY	TOTAL SHEETS	SHEET NO.
57	1919.2B	COOK	119	64
STA.		TO STA.		
FED. ROAD DIST. NO.		ILLINOIS FED. AID PROJECT		

CONTRACT #60371

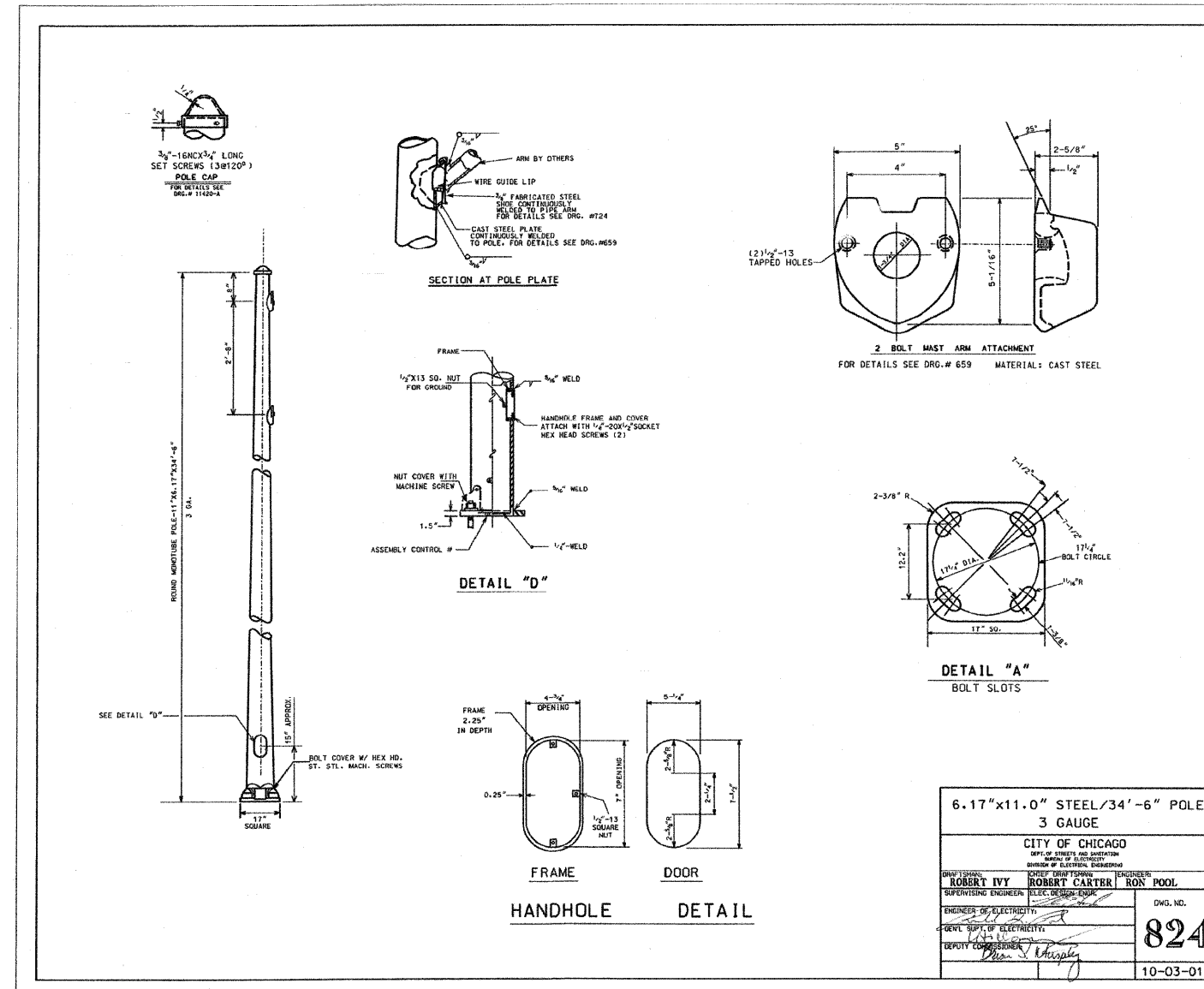
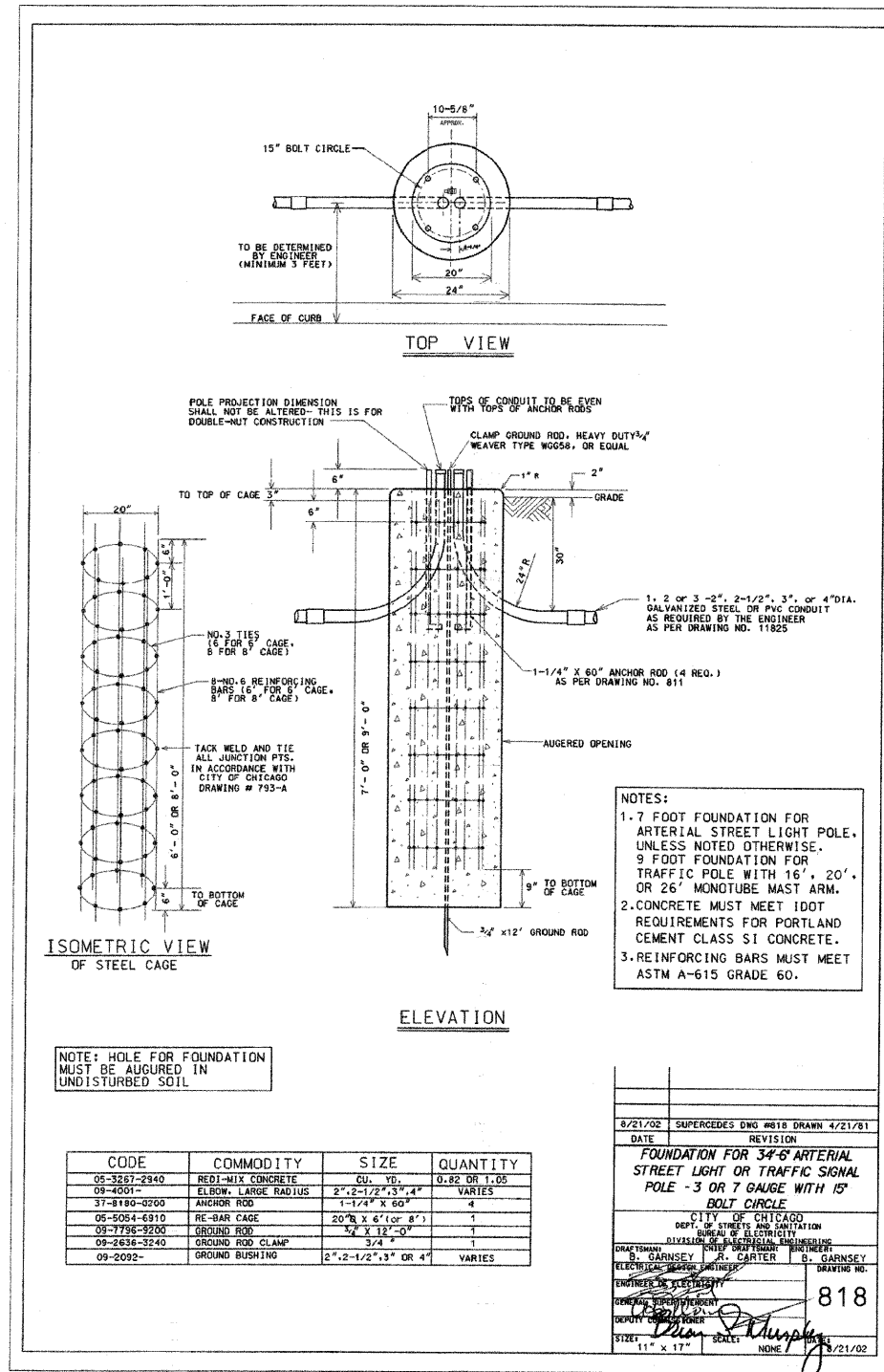

\* CITY OF CHICAGO BUREAU OF ELECTRICITY STANDARD DRAWINGS ARE PROVIDED IN ENGLISH UNITS.

**SINGH** SINGH & ASSOCIATES, INC.  
CONSULTING ENGINEERS

REVISIONS		ILLINOIS DEPARTMENT OF TRANSPORTATION 115TH STREET OVER I-57 CITY OF CHICAGO BUREAU OF ELECTRICITY STANDARD DRAWINGS
NAME	DATE	
		SCALE: NONE DATE: 01-16-09 DRAWN BY: VG CHECKED BY: PV



F.A.I. RTE.	SECTION	COUNTY	TOTAL SHEETS	SHEET NO.
57	1919.2B	COOK	119	65
STA.	TO STA.			
FED. ROAD DIST. NO.	ILLINOIS	FED. AID PROJECT		

CONTRACT #60371

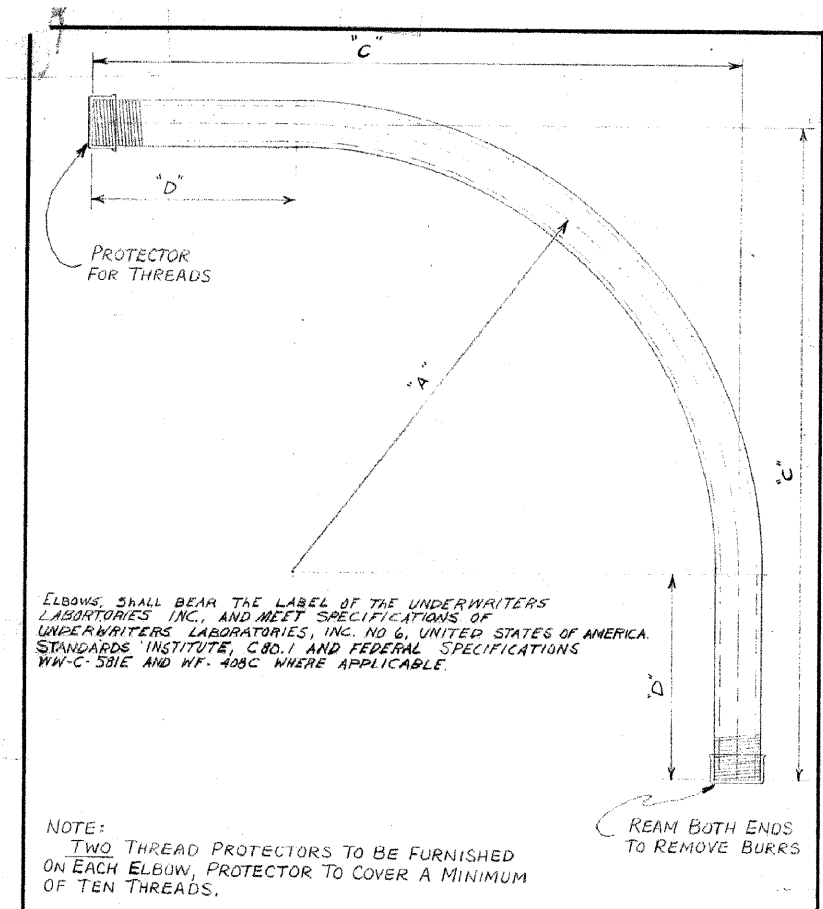
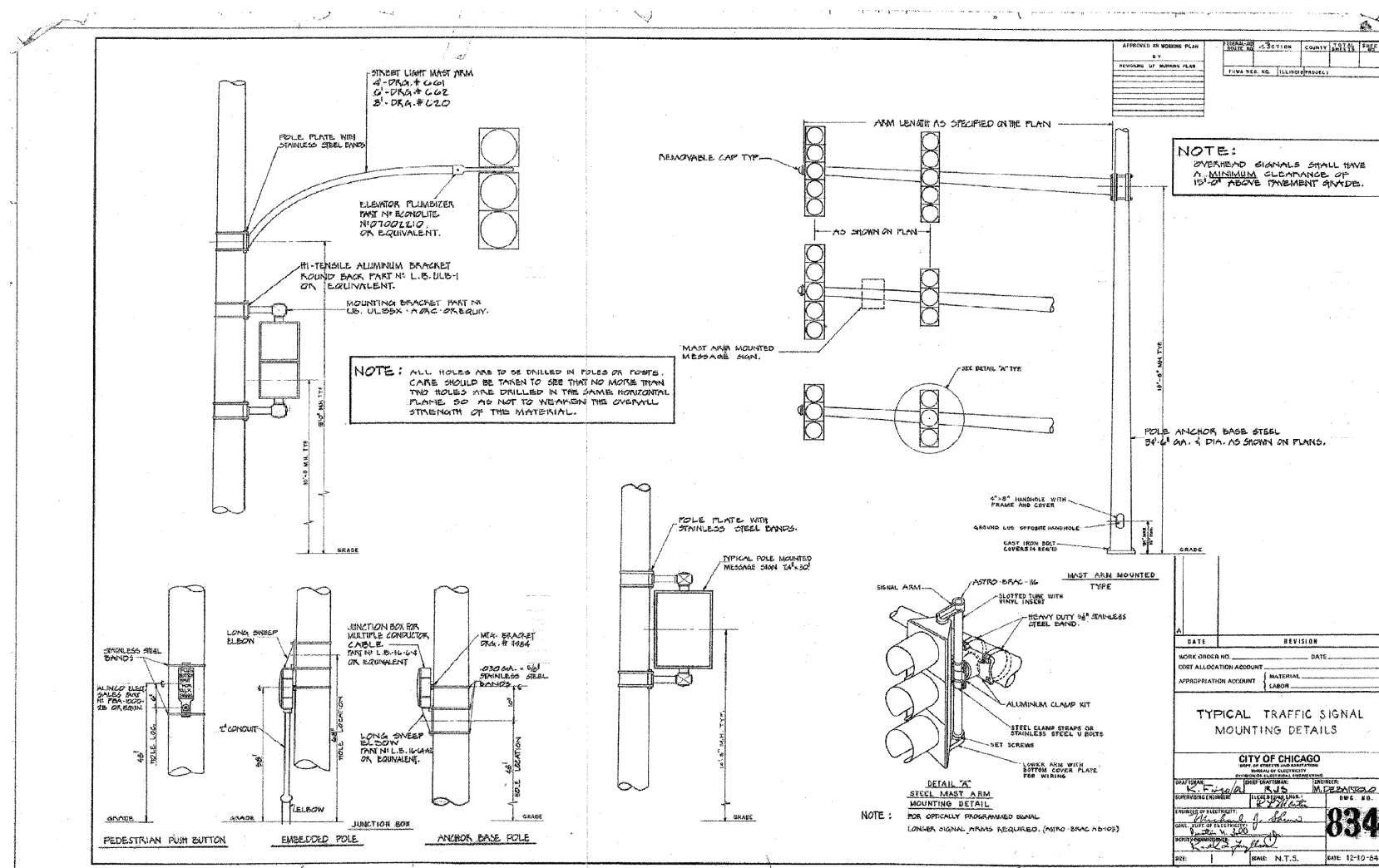

TABLE OF DIMENSIONS

CONDUIT SIZE	A"	B"	C"	D"	COMMODITY CODE
1 1/4"	24"	35"	11"		09-4001-0510
1 1/2"	24"	35"	11"		09-4001-0520
2"	24"	35"	11"		09-4001-4126
2 1/2"	24"	35"	11"		09-4001-4128
3"	24"	35"	11"		09-4001-4230
4"	24"	35"	11"		09-4001-0000

B SPECIFICATIONS REVISED

A REVISED DIMENSIONS ON 3" & 4" CONDUIT L.P.

ELBOW, CONDUIT, RIGID GALVANIZED STEEL, LARGE RADIUS

REVISED	CITY OF CHICAGO	
A 7-22-71	DEPT. OF STREETS AND SANITATION	
B 7-3-73	BUREAU OF ELECTRICITY	
C	DIVISION OF ELECTRICAL ENGINEERING	
D	DRAWN BY: LON BURD	CHECKED BY: M. SHINE
E	DESIGNED BY: M. SHINE	ENGR. NO. 11825
F	DATE: 6-2-71	
G	SCALE: 3/16"	DATE: 6-2-71

APPROVED AS WORKING PLAN

REVISIONS

DATE	REVISION

WORK ORDER NO. \_\_\_\_\_ DATE \_\_\_\_\_

COST ALLOCATION ACCOUNT \_\_\_\_\_

APPROPRIATION ACCOUNT \_\_\_\_\_

TYPICAL TRAFFIC SIGNAL MOUNTING DETAILS

CITY OF CHICAGO

834

DATE: 12-10-66

CITY OF CHICAGO BUREAU OF ELECTRICITY STANDARD DRAWINGS ARE PROVIDED IN ENGLISH UNITS.

SINGH SINGH & ASSOCIATES, INC. CONSULTING ENGINEERS

REVISIONS		ILLINOIS DEPARTMENT OF TRANSPORTATION
NAME	DATE	
		115TH STREET OVER I-57 CITY OF CHICAGO BUREAU OF ELECTRICITY STANDARD DRAWINGS

SCALE: NONE      DRAWN BY: VG

DATE: 01-16-09      CHECKED BY: PV

F.A.I. RTE.	SECTION	COUNTY	TOTAL SHEETS	SHEET NO.
57	1919.2B	COOK	119	66
STA.		TO STA.		
FED. ROAD DIST. NO.		ILLINOIS FED. AID PROJECT		

CONTRACT #60371

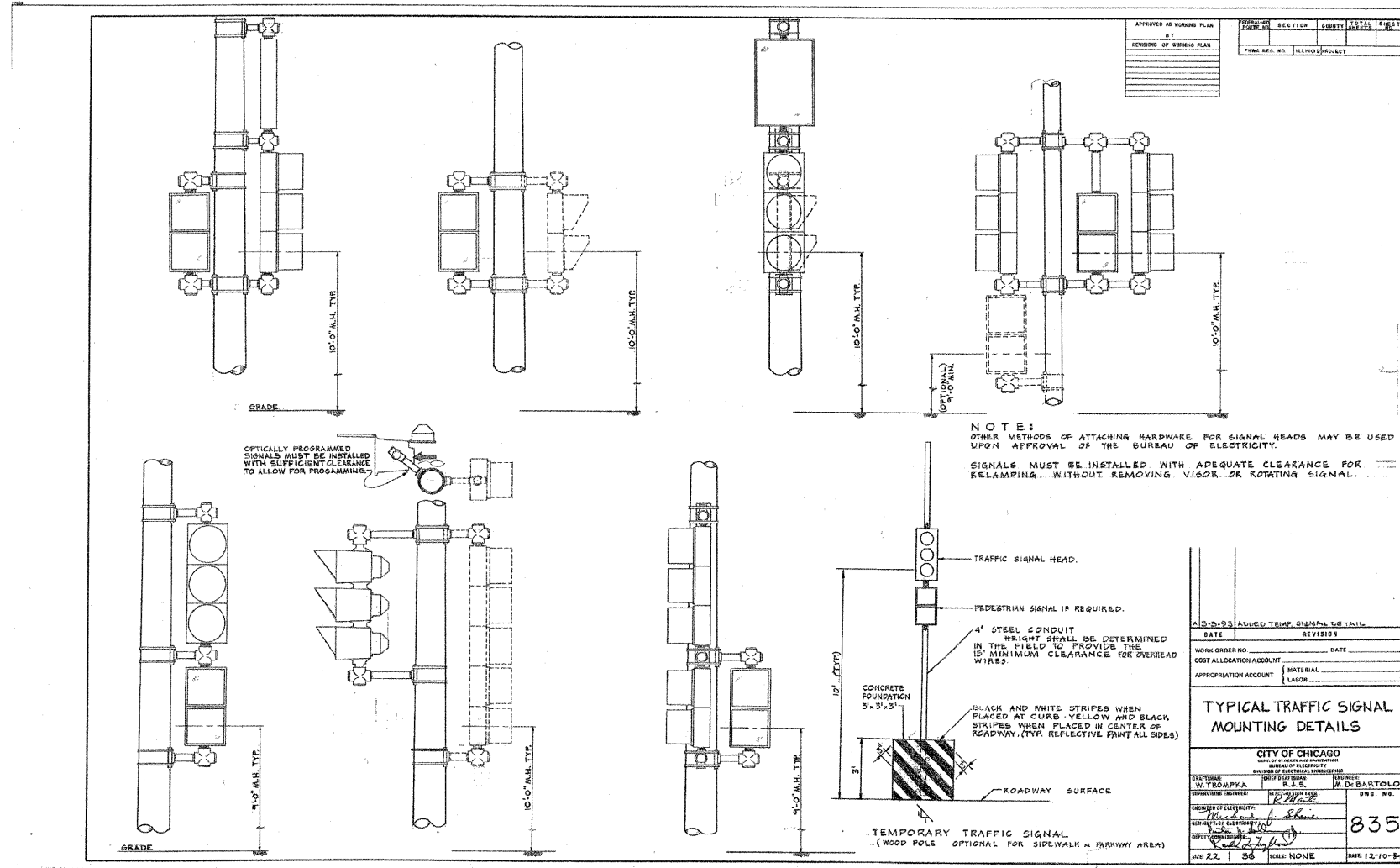

BANDING FITTING FOR POLE MOUNTING JUNCTION BOX

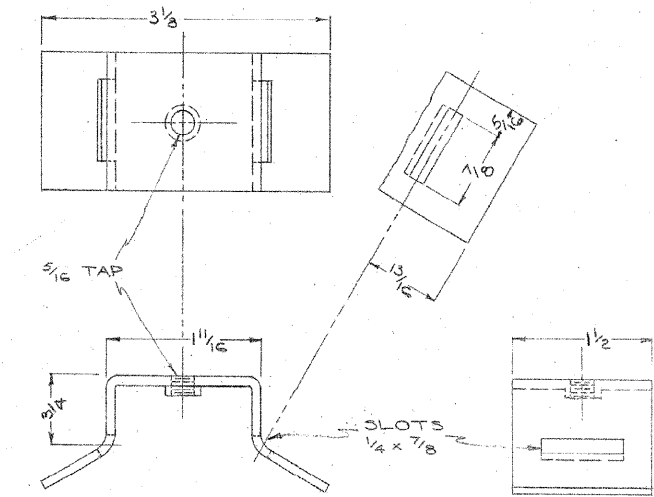

MATERIAL: STAINLESS STEEL - 4 1/2 x 1 1/2 x 3/32

BANDING FITTING FOR POLE MOUNTING SIGNALS

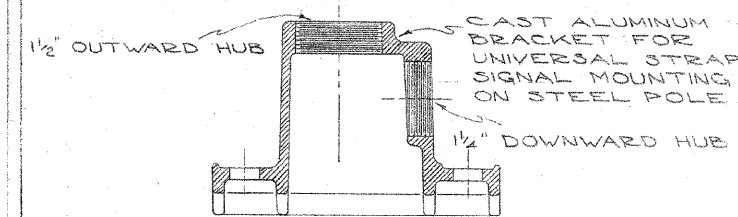

MATERIAL: CAST ALUMINUM

APPROVED AS WORKING PLAN

REVISION OF WORKING PLAN

DATE	REVISION

WORK ORDER NO. \_\_\_\_\_ DATE \_\_\_\_\_

COST ALLOCATION ACCOUNT \_\_\_\_\_ MATERIAL \_\_\_\_\_

APPROPRIATION ACCOUNT \_\_\_\_\_ LABOR \_\_\_\_\_

**TYPICAL TRAFFIC SIGNAL MOUNTING DETAILS**

CITY OF CHICAGO  
DEPT. OF STREETS AND SANITATION  
DIVISION OF ELECTRICAL ENGINEERING

DESIGNED BY: W. TRIMPLER  
CHECKED BY: M. DEBARTOLO  
DATE: 12-10-84

835

BANDING FITTINGS FOR POLE MOUNTING TRAFFIC SIGNAL

CROUSE HINDS  
TL-3301-WITHOUT DOWNWARD HUB  
TL-3302 WITH 1/4" DOWNWARD HUB

BANDING FITTINGS FOR POLE MOUNTING TRAFFIC SIGNAL

CITY OF CHICAGO  
DEPT. OF STREETS AND SANITATION  
DIVISION OF ELECTRICAL ENGINEERING

DATE: 11-14-84

11984

CITY OF CHICAGO BUREAU OF ELECTRICITY  
STANDARD DRAWINGS ARE PROVIDED IN ENGLISH UNITS.

REVISIONS	
NAME	DATE

ILLINOIS DEPARTMENT OF TRANSPORTATION  
115TH STREET OVER I-57  
CITY OF CHICAGO  
BUREAU OF ELECTRICITY  
STANDARD DRAWINGS

SCALE: NONE  
DATE: 01-16-09

DRAWN BY: VG  
CHECKED BY: PV

SINGH SINGH & ASSOCIATES, INC.  
CONSULTING ENGINEERS

F.A.I. RTE.	SECTION	COUNTY	TOTAL SHEETS	SHEET NO.
57	1919.2B	COOK	119	67
STA.		TO STA.		
FED. ROAD DIST. NO.		ILLINOIS FED. AID PROJECT		

CONTRACT #60371

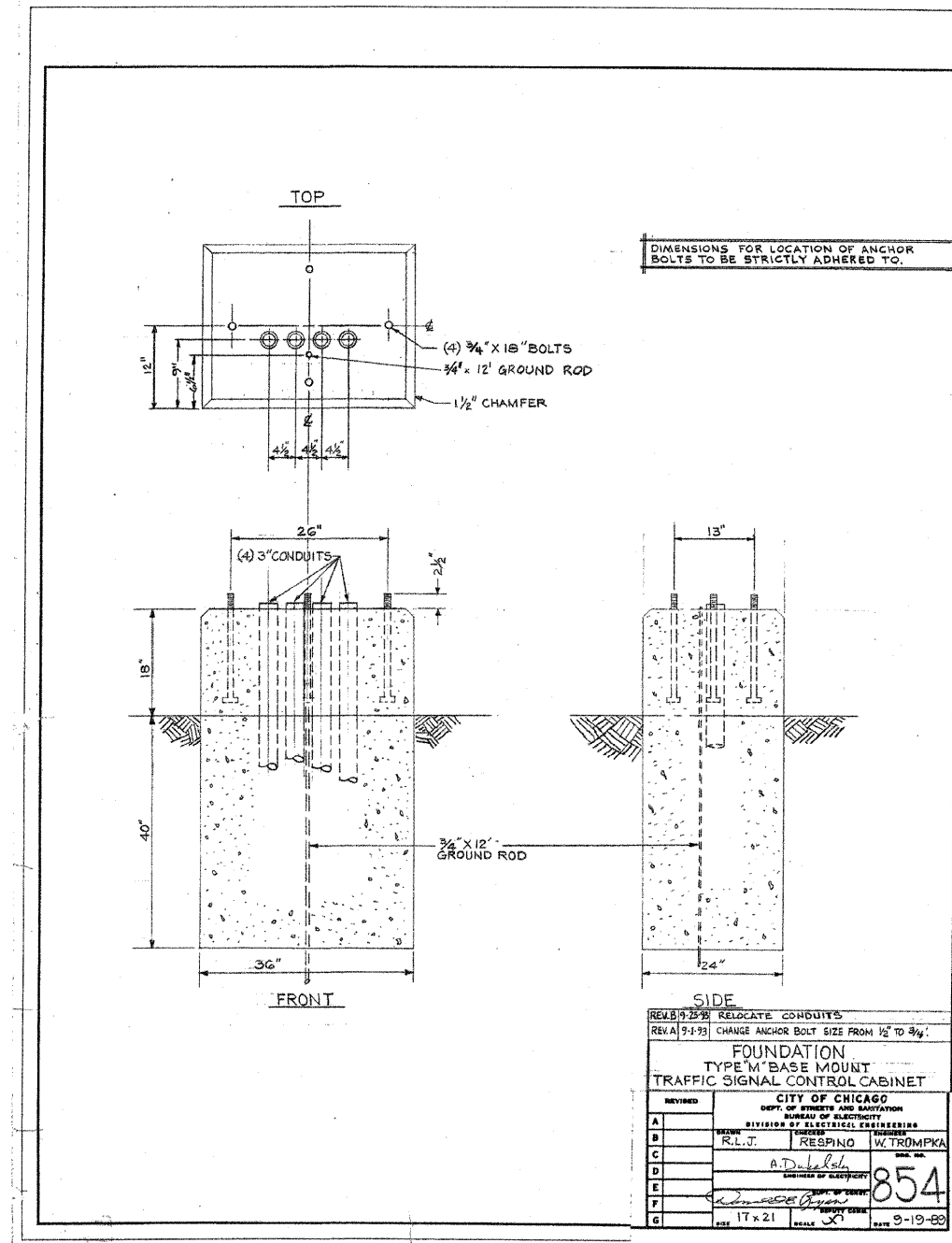
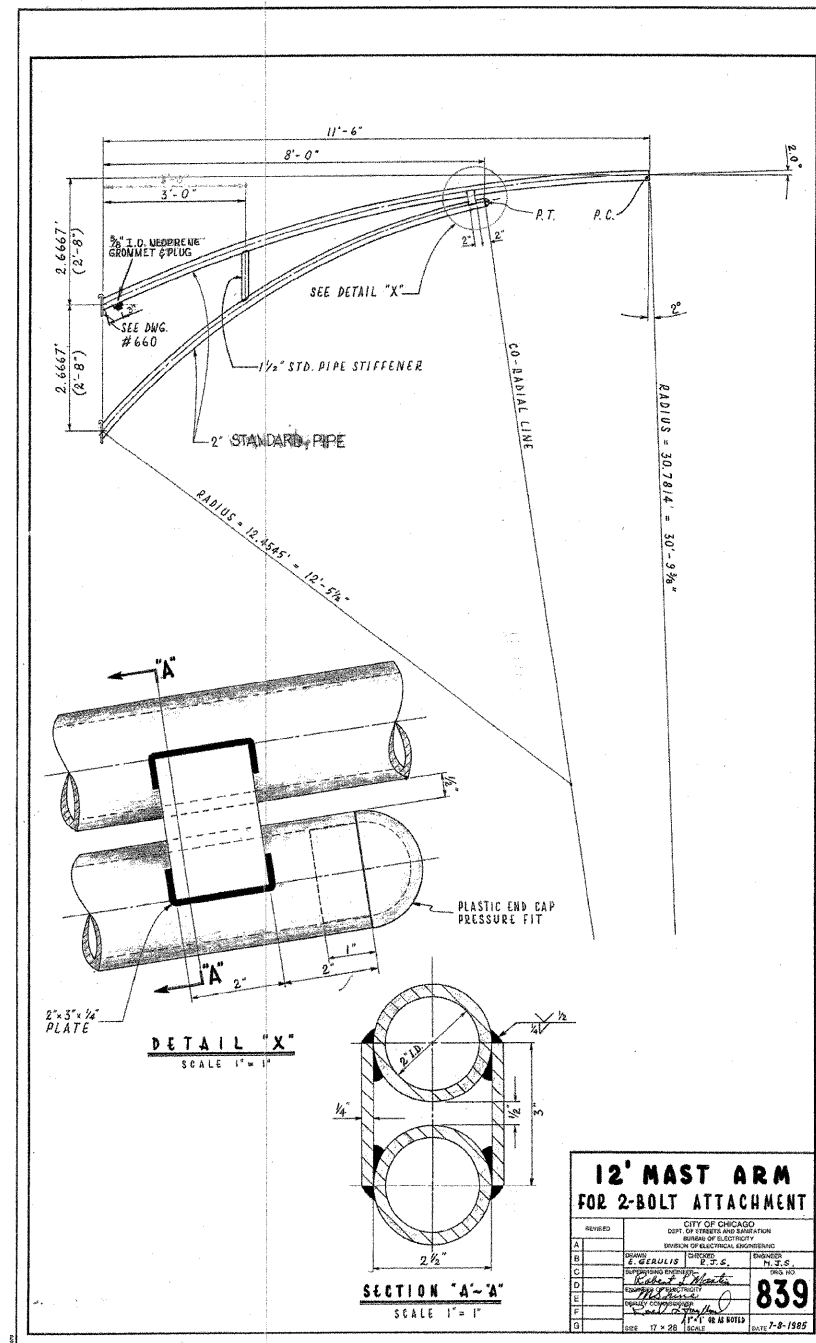

• CITY OF CHICAGO BUREAU OF ELECTRICITY  
STANDARD DRAWINGS ARE PROVIDED IN ENGLISH  
UNITS.

**SINGH** SINGH & ASSOCIATES, INC.  
CONSULTING ENGINEERS

REVISIONS	
NAME	DATE

ILLINOIS DEPARTMENT OF TRANSPORTATION  
115TH STREET OVER I-57  
CITY OF CHICAGO  
BUREAU OF ELECTRICITY  
STANDARD DRAWINGS  
SCALE: NONE  
DATE: 01-16-09  
DRAWN BY: VG  
CHECKED BY: PV

F.A.I. RTE.	SECTION	COUNTY	TOTAL SHEETS	SHEET NO.
57	1919.2B	COOK	119	68
STA.		TO STA.		
FED. ROAD DIST. NO.		ILLINOIS FED. AID PROJECT		

CONTRACT #60371

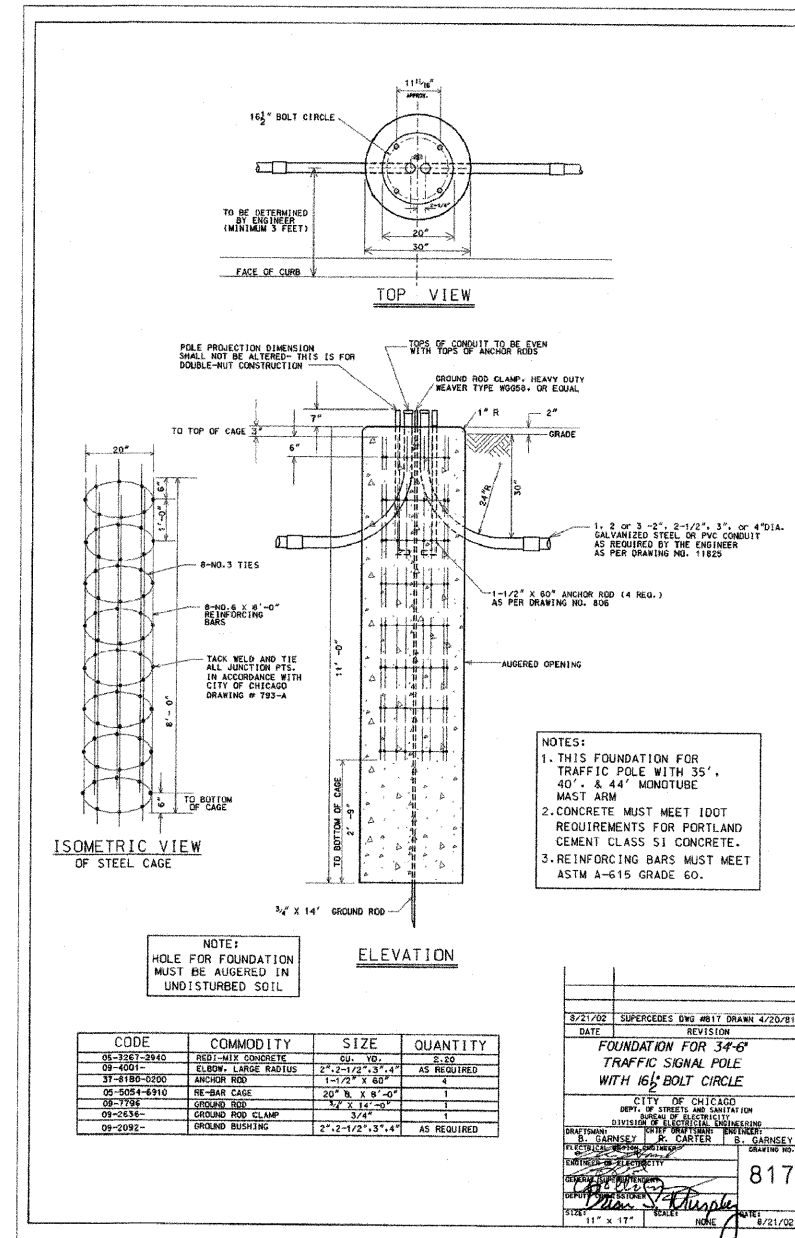
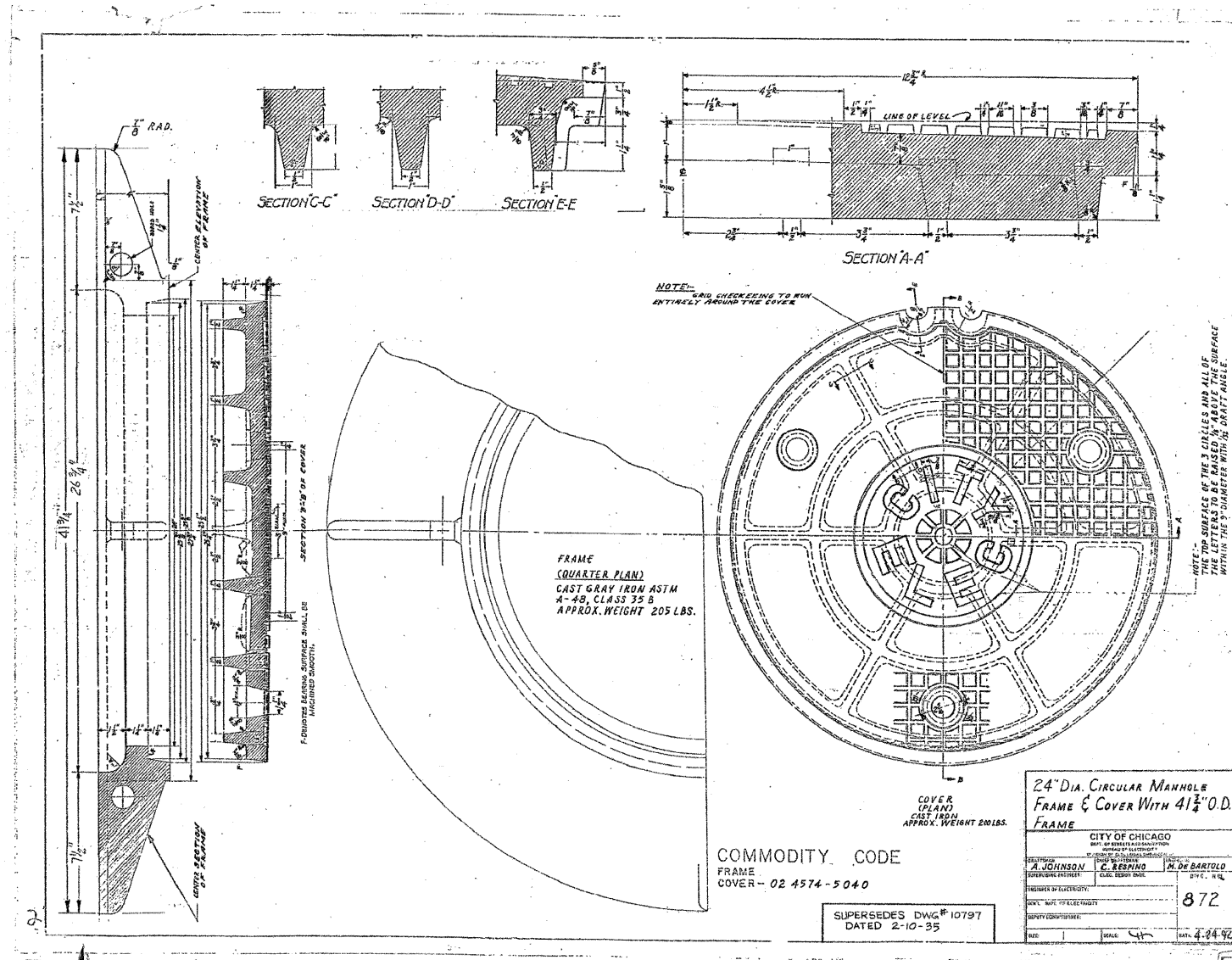

CITY OF CHICAGO BUREAU OF ELECTRICITY  
STANDARD DRAWINGS ARE PROVIDED IN ENGLISH  
UNITS.

SINGH SINGH & ASSOCIATES, INC.  
CONSULTING ENGINEERS

REVISIONS	
NAME	DATE

ILLINOIS DEPARTMENT OF TRANSPORTATION  
115TH STREET OVER I-57  
CITY OF CHICAGO  
BUREAU OF ELECTRICITY  
STANDARD DRAWINGS  
SCALE: NONE  
DATE: 01-16-09  
DRAWN BY: VG  
CHECKED BY: PV

F.A.I. RTE.	SECTION	COUNTY	TOTAL SHEETS	SHEET NO.
57	1919.2B	COOK	119	69
STA.		TO STA.		
FED. ROAD DIST. NO.		ILLINOIS FED. AID PROJECT		

CONTRACT #60371

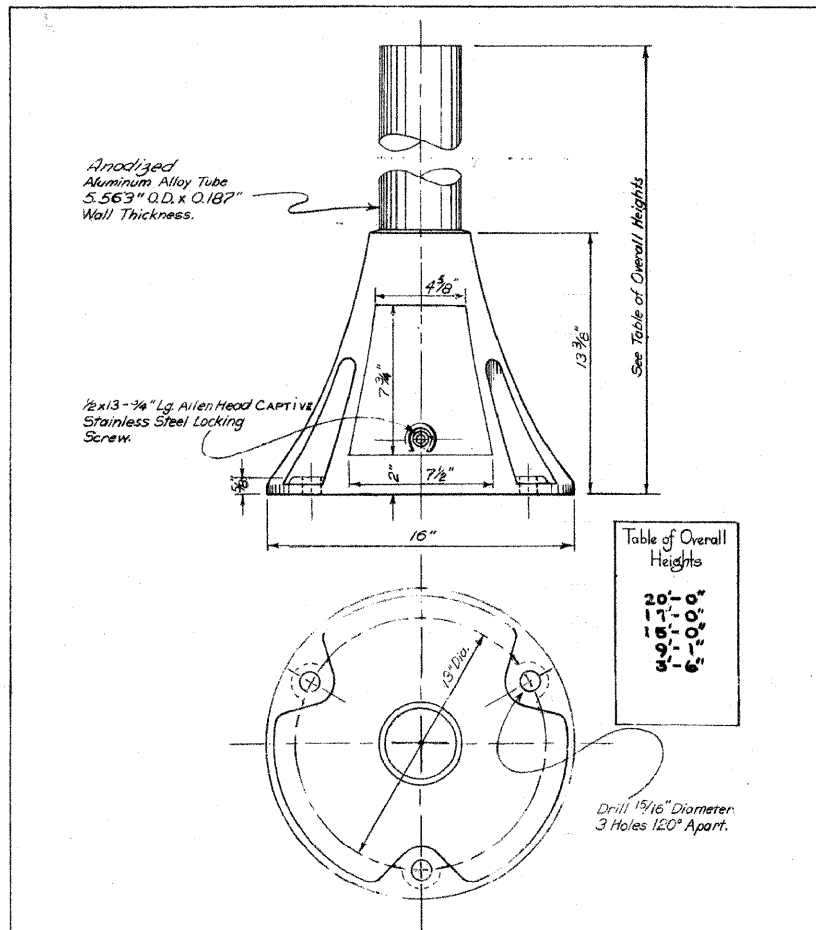
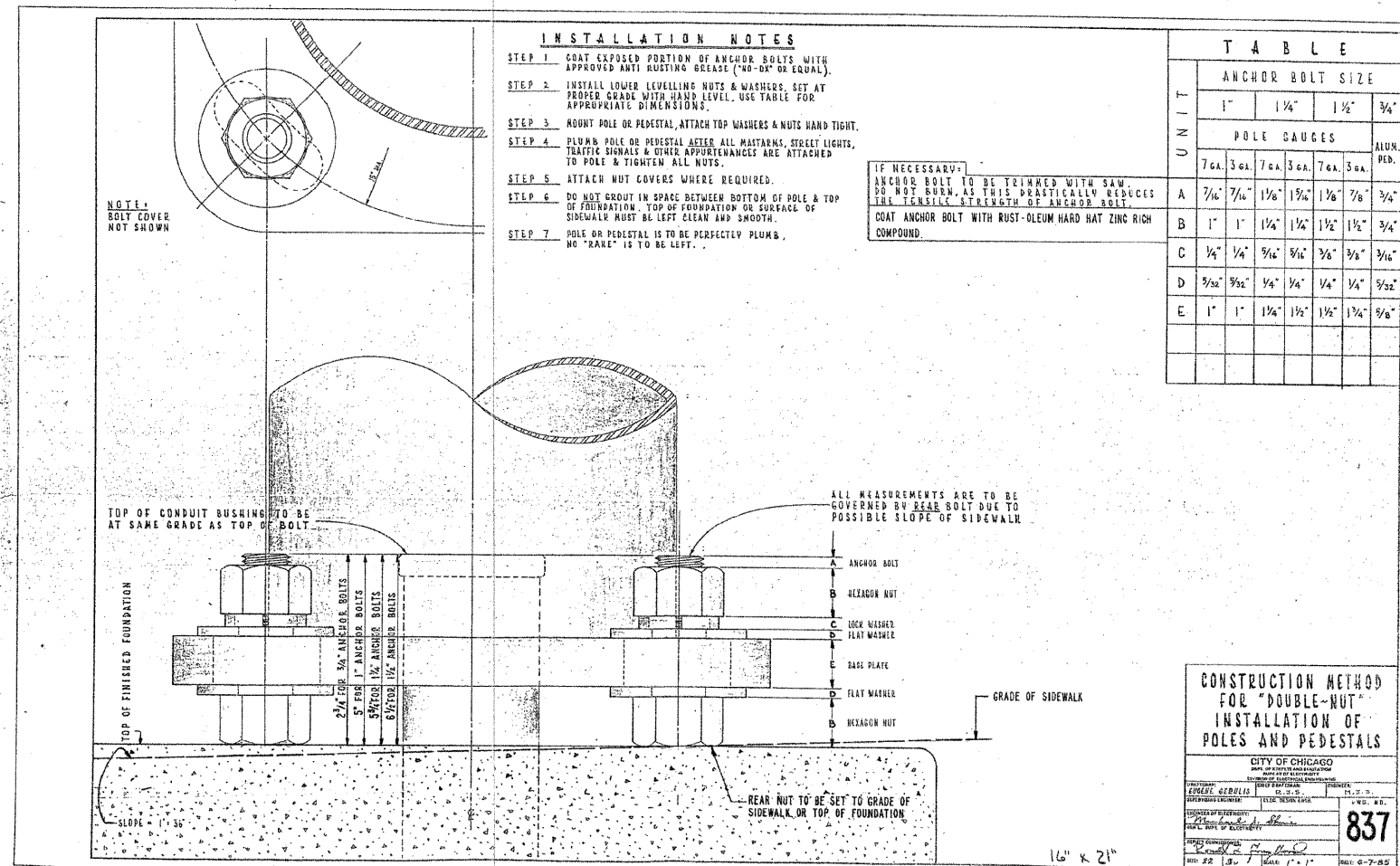

Table of Overall Heights

20'-0"
17'-0"
15'-0"
9'-1"
3'-6"

ALUMINUM PEDESTAL BASE WITH HANDHOLE  
for  
Street Lighting Controller, Traffic Signal  
Controller and Traffic Signal Heads.

REVISED		CITY OF CHICAGO DEPT. OF STREETS AND SANITATION DIVISION OF ELECTRICAL ENGINEERING	
J CHANGED OVERALL HEIGHTS 5-22-84	A 5-5-60	DRAWN R. COLLEY	CHECKED J. BORE
Revised Table of Overall Heights	B 6-30-60	ENGINEER Ruzicka	
Revised O.D. of Pedestal	C 12-21-60	DRG. NO. 526	
Revised Specification Number	D 3-23-62	DATE IN CHARGE	
Revised Table of Overall Heights	E 6-4-64	DATE OF CONSTRUCTION	
Revised Door Dimensions	F 7-14-71	DATE OF COMPLETION	
Revised Overall Heights	G OCT. 26, 73	DATE 4-13-69	
Revised Overall Heights	H 3-4-79	SCALE 1/8" = 1"	



INSTALLATION NOTES

- STEP 1 COAT EXPOSED PORTION OF ANCHOR BOLTS WITH APPROVED ANTI RUSTING GREASE ("80-02" OR EQUAL).
- STEP 2 INSTALL LOWER LEVELLING NUTS & WASHERS. SET AT PROPER GRADE WITH HAND LEVEL. USE TABLE FOR APPROPRIATE DIMENSIONS.
- STEP 3 MOUNT POLE OR PEDESTAL, ATTACH TOP WASHERS & NUTS HAND TIGHT.
- STEP 4 PLUMB POLE OR PEDESTAL AFTER ALL MASTARMS, STREET LIGHTS, TRAFFIC SIGNALS & OTHER APPURTENANCES ARE ATTACHED TO POLE & TIGHTEN ALL NUTS.
- STEP 5 ATTACH NUT COVERS WHERE REQUIRED.
- STEP 6 DO NOT GROUT IN SPACE BETWEEN BOTTOM OF POLE & TOP OF FOUNDATION. TOP OF FOUNDATION OR SURFACE OF SIDEWALK MUST BE LEFT CLEAN AND SMOOTH.
- STEP 7 POLE OR PEDESTAL IS TO BE PERFECTLY PLUMB. NO "RAKE" IS TO BE LEFT.

T A B L E

UNIT	ANCHOR BOLT SIZE			
	1"	1 1/4"	1 1/2"	3/4"
POLE GAUGES	7 ea. 3 ea.	7 ea. 3 ea.	7 ea. 3 ea.	ALUM. PED.
	A 7/16"	7/16"	15/16"	15/16"
B	1"	1"	1 1/4"	1 1/2"
C	1 1/4"	1 1/4"	1 1/2"	1 1/2"
D	1 1/2"	1 1/2"	1 3/4"	1 3/4"
E	2"	2"	2 1/4"	2 1/4"

CONSTRUCTION METHOD FOR "DOUBLE-NUT" INSTALLATION OF POLES AND PEDESTALS

CITY OF CHICAGO  
DEPT. OF STREETS AND SANITATION  
DIVISION OF ELECTRICAL ENGINEERING

PROJECT NO.	1919.2B	DATE	10-22-84
DESIGNED BY	R. COLLEY	CHECKED BY	J. BORE
ENGINEER	Ruzicka	DATE IN CHARGE	
DATE OF CONSTRUCTION		DATE OF COMPLETION	
SCALE	1/8" = 1"	DATE	4-13-69

837

CITY OF CHICAGO BUREAU OF ELECTRICITY  
STANDARD DRAWINGS ARE PROVIDED IN ENGLISH  
UNITS.

REVISIONS	
NAME	DATE

ILLINOIS DEPARTMENT OF TRANSPORTATION  
115TH STREET OVER I-57  
CITY OF CHICAGO  
BUREAU OF ELECTRICITY  
STANDARD DRAWINGS

SCALE: NONE  
DATE: 01-16-09

DRAWN BY: VG  
CHECKED BY: PV

SINGH SINGH & ASSOCIATES, INC.  
CONSULTING ENGINEERS



F.A.I. RTE.	SECTION	COUNTY	TOTAL SHEETS	SHEET NO.
57	1919.2B	COOK	119	71
STA.		TO STA.		
FED. ROAD DIST. NO.		ILLINOIS FED. AID PROJECT		

CONTRACT #60371

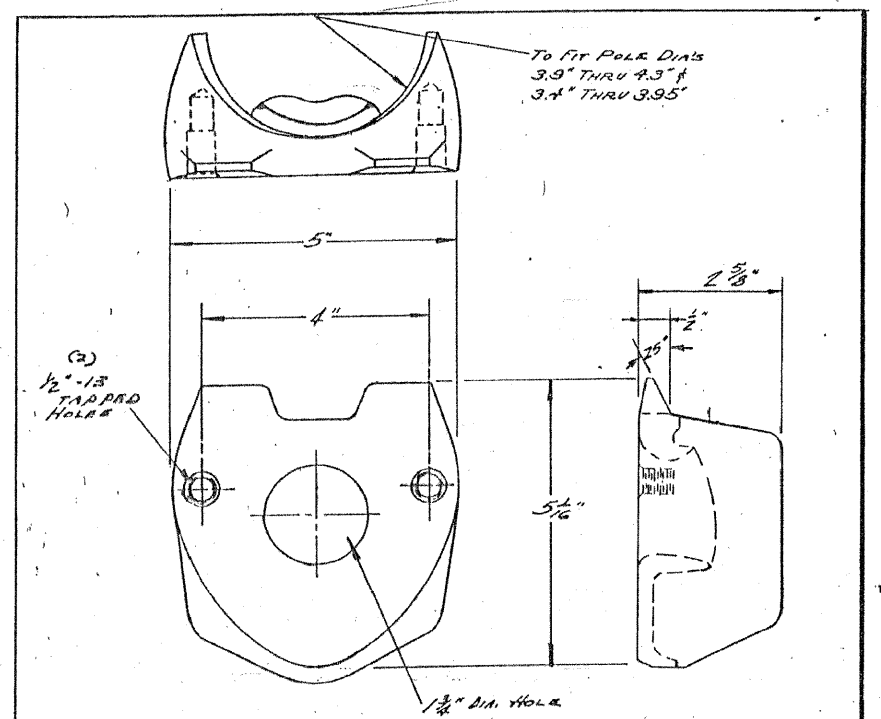

MATERIAL: CAST STEEL

A J.O.C. MATERIAL NOTE ADDED.	
2 BOLT MAST ARM ATTACHMENT POLE PLATE DETAILS	
CITY OF CHICAGO DEPT. OF STREETS AND SANITATION DIVISION OF ELECTRICAL ENGINEERING	
REVISED	DATE
A	5-27-76
B	
C	
D	
E	
F	
G	
DRAWN: J. WAHLFELDT CHECKED: U. BORE ENGINEER: J. BORE	
DESIGNED: [Signature] IN CHARGE: [Signature]	
SUPERVISOR: [Signature] DATE: 10-25-68	
Dwg. No. 659	
MIR 8 1/2" x 11" SCALE 1/8" = 1'-0" DATE 10-25-68	

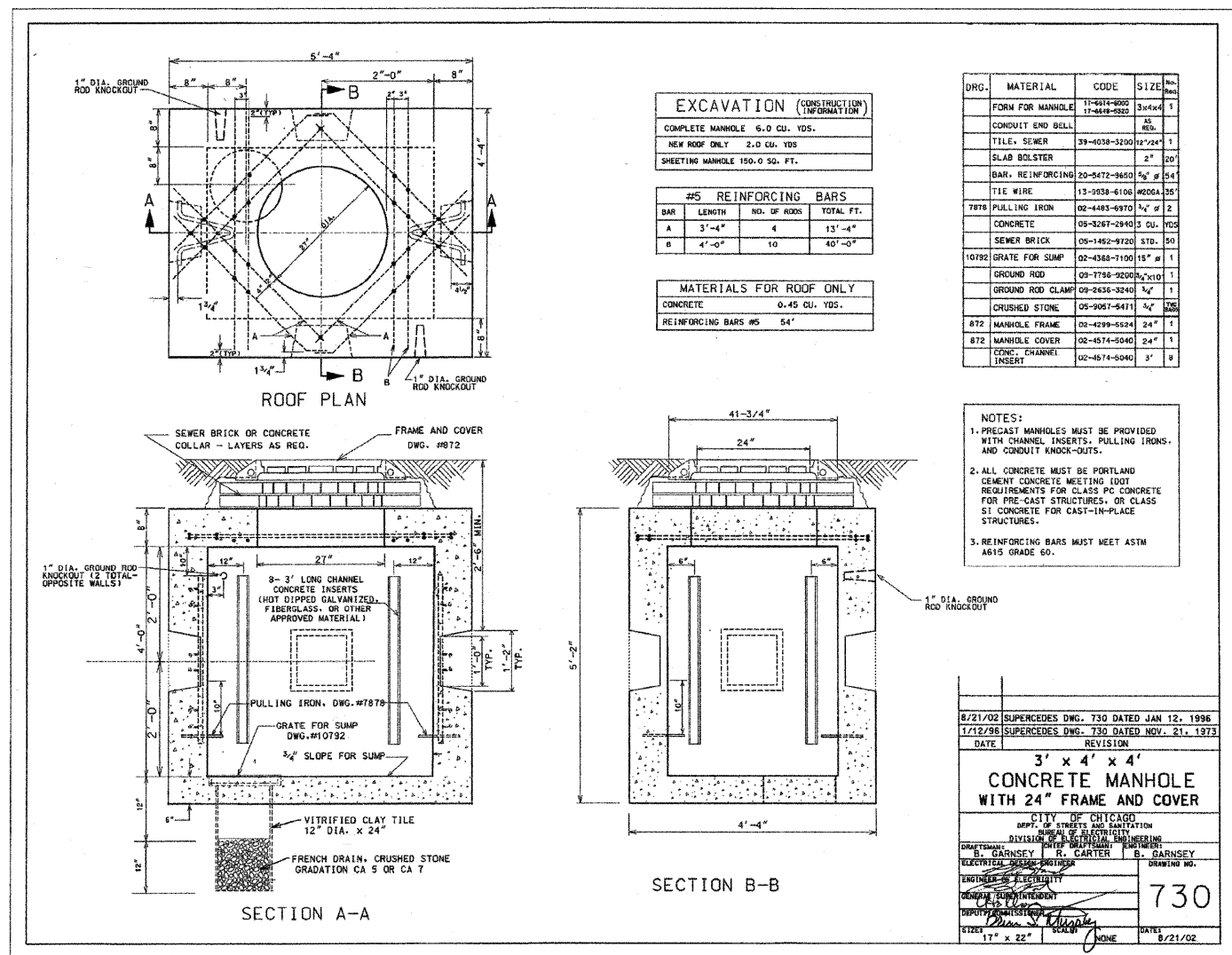

\* CITY OF CHICAGO BUREAU OF ELECTRICITY STANDARD DRAWINGS ARE PROVIDED IN ENGLISH UNITS.

SINGH SINGH & ASSOCIATES, INC. CONSULTING ENGINEERS

REVISIONS	
NAME	DATE

ILLINOIS DEPARTMENT OF TRANSPORTATION  
115TH STREET OVER I-57  
CITY OF CHICAGO  
BUREAU OF ELECTRICITY  
STANDARD DRAWINGS  
SCALE: NONE  
DATE: 01-16-09  
DRAWN BY: VG  
CHECKED BY: PV

F.A.I. RTE.	SECTION	COUNTY	TOTAL SHEETS	SHEET NO.
57	1919.2B	COOK	119	72
STA.		TO STA.		
FED. ROAD DIST. NO.		ILLINOIS FED. AID PROJECT		

CONTRACT #60371

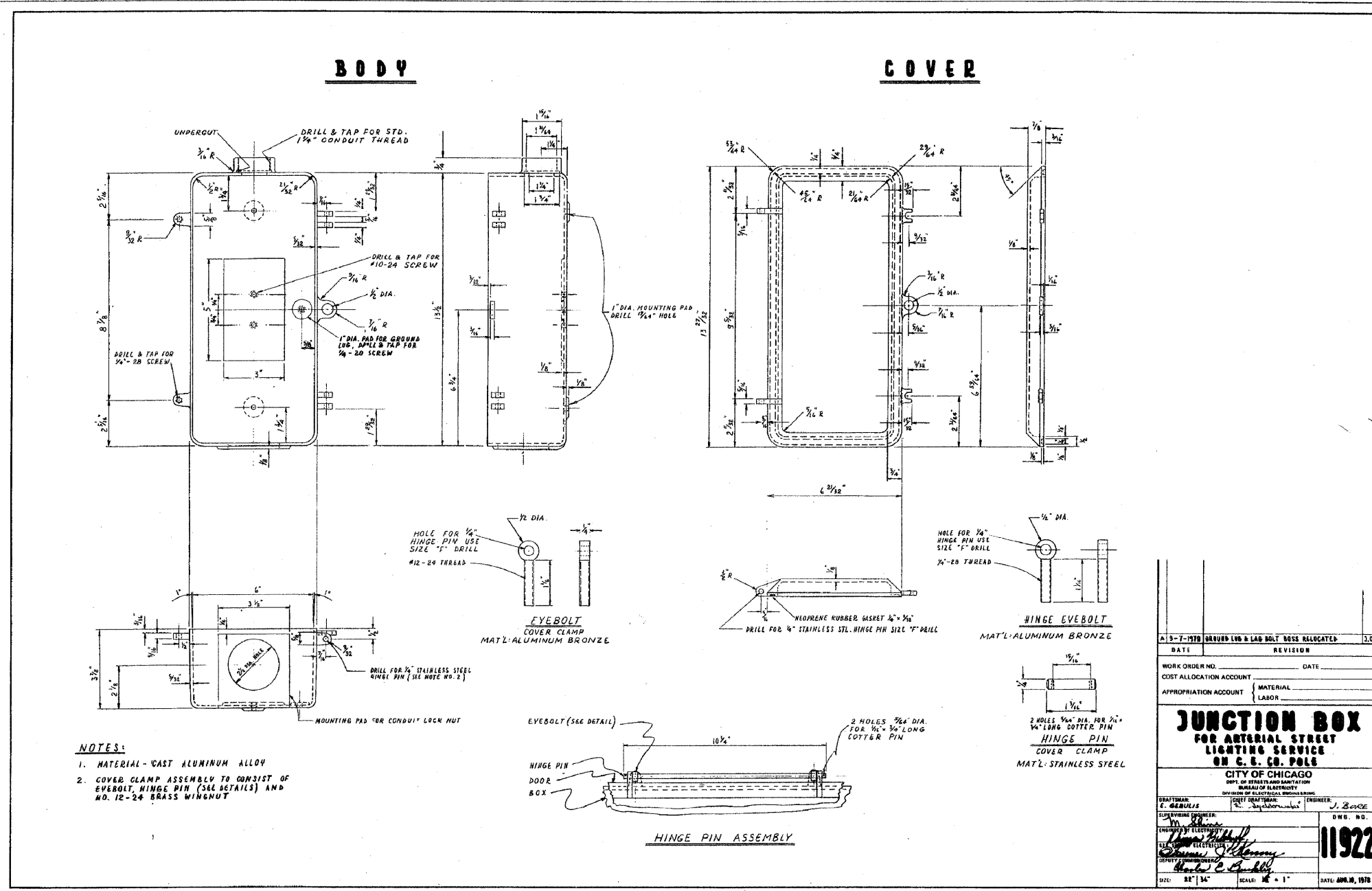

- NOTES:**
1. MATERIAL - CAST ALUMINUM ALLOY
  2. COVER CLAMP ASSEMBLY TO CONSIST OF EYEBOLT, HINGE PIN (SEE DETAILS) AND NO. 12-24 BRASS WINGNUT

A 3-7-1978 ORDER LWB & LAB BOLT NOSE ALLOCATED J.D.C.	
DATE	REVISION
WORK ORDER NO.	DATE
COST ALLOCATION ACCOUNT	
APPROPRIATION ACCOUNT	MATERIAL
	LABOR
<b>JUNCTION BOX</b> FOR ARTERIAL STREET LIGHTING SERVICE ON C. C. POLS	
CITY OF CHICAGO DEPT. OF STREET LIGHTS AND SIGNALS BUREAU OF ELECTRICITY DIVISION OF ELECTRICAL ENGINEERING	
DRAWN BY: E. GEBRALLE	ENGINEER: J. BOCKE
CHECKED BY: [Signature]	DWG. NO. 11922
DATE: APR. 10, 1978	

CITY OF CHICAGO BUREAU OF ELECTRICITY  
STANDARD DRAWINGS ARE PROVIDED IN ENGLISH  
UNITS.

**SINGH** SINGH & ASSOCIATES, INC.  
CONSULTING ENGINEERS

REVISIONS	
NAME	DATE

ILLINOIS DEPARTMENT OF TRANSPORTATION  
115TH STREET OVER I-57  
CITY OF CHICAGO  
BUREAU OF ELECTRICITY  
STANDARD DRAWINGS  
SCALE: NONE  
DATE: 01-16-09  
DRAWN BY: VG  
CHECKED BY: PV



F.A.I. RTE.	SECTION	COUNTY	TOTAL SHEETS	SHEET NO.
57	1919.2B	COOK	119	73
STA.		TO STA.		
FED. ROAD DIST. NO.		ILLINOIS FED. AID PROJECT		

CONTRACT #60371

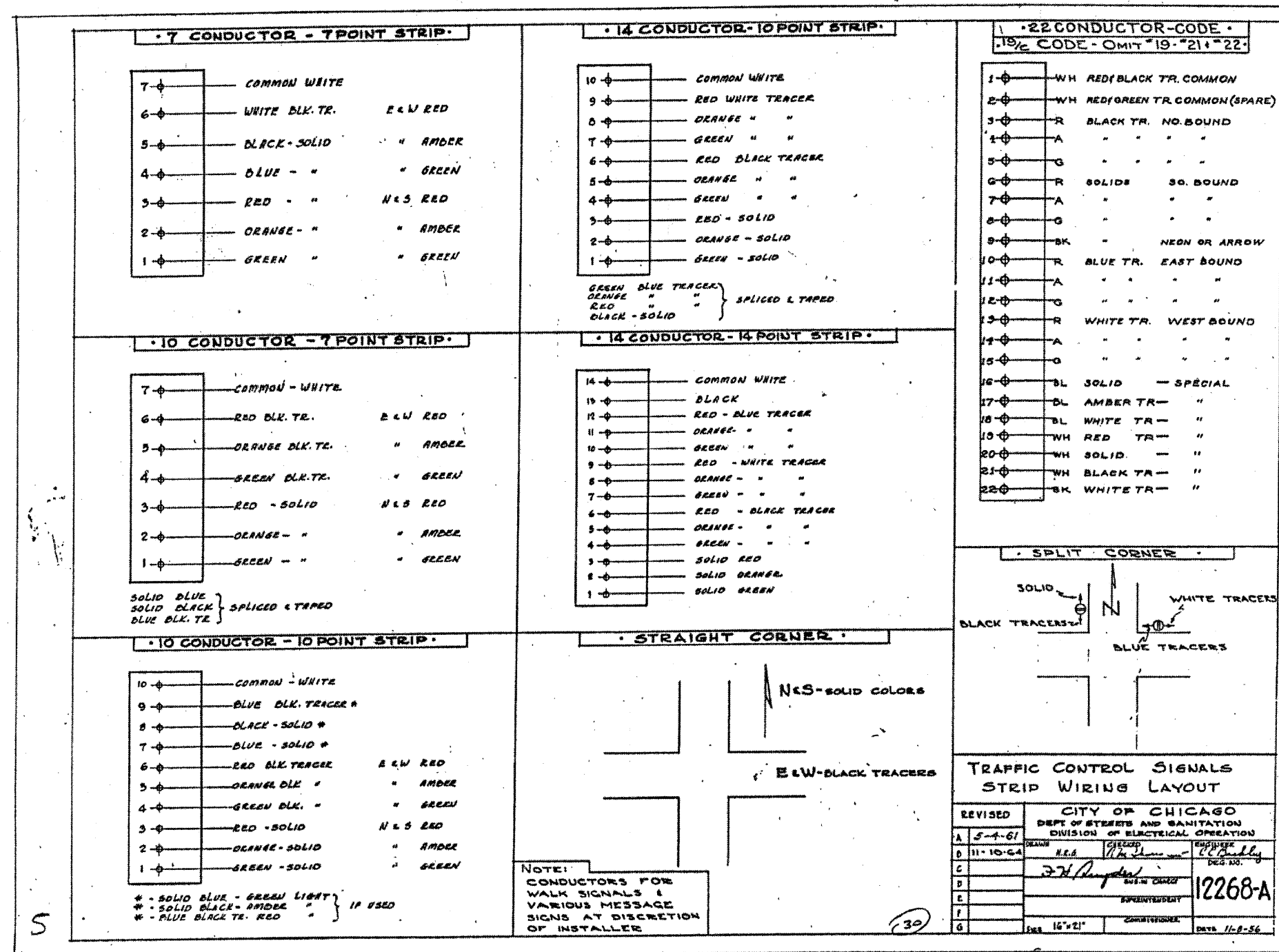

\* CITY OF CHICAGO BUREAU OF ELECTRICITY STANDARD DRAWINGS ARE PROVIDED IN ENGLISH UNITS.

SINGH SINGH & ASSOCIATES, INC. CONSULTING ENGINEERS

REVISIONS	
NAME	DATE

ILLINOIS DEPARTMENT OF TRANSPORTATION  
115TH STREET OVER I-57  
CITY OF CHICAGO  
BUREAU OF ELECTRICITY  
STANDARD DRAWINGS

SCALE: NONE  
DATE: 01-16-09  
DRAWN BY: VG  
CHECKED BY: PV

Bench Mark:  
No. 384 El. 185.482 120th Street and Justine Street  
2.682 m West of East Line of Justine Street and 6.645 m South of South Line of 120th Street

Existing Structure: S.N. 016-2037 a two span continuous steel beam structure with a back to back length of 57.022 m and out to out width of 25.3 m with a minimum horizontal clearance of 2.667 m at the East Abutment and a minimum vertical underclearance of 4.664 m, supported on closed abutments and pier with no skew. Built as FAI Route 57, Section 068-1919.2-CF in 1965. Traffic shall be maintained during the rehabilitation of the structure by staged construction.

Note:  
All dimensions are in millimeters (mm) except as noted.

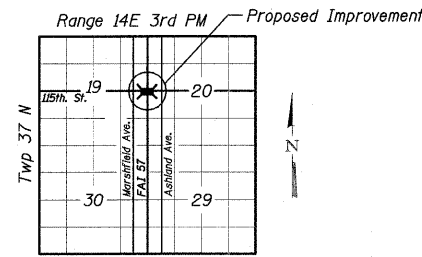

LOCATION SKETCH

**DESIGN SPECIFICATIONS**

1996 AASHTO Standard Specifications for Highway Bridges, including 1997, 1998 & 1999 Interims

**LOADING MS18**

Allow 1.2 kN/m<sup>2</sup> for future wearing surface.

**DESIGN STRESSES**

$f'_c = 24 \text{ MPa}$  (Existing & Proposed)  
 $f_y = 276 \text{ MPa}$  (Reinf. Existing)  
 $f_y = 400 \text{ MPa}$  (Reinf. Proposed)  
 $f_y = 345 \text{ MPa}$  (M 270M Grade 345) (Proposed)  
 $f_y = 250 \text{ MPa}$  (M 270M Grade 250) (Existing & Proposed)

**SEISMIC DATA**

Seismic Performance Category (SPC) = A  
Bedrock Acceleration Coefficient (A) = 0.04g  
Site coefficient (S) = 1.0

ROUTE NO.	SECTION	COUNTY	TOTAL SHEETS	SHEET NO.
FAU 1584	*	COOK	119	74
FED. ROAD DIST. NO. 7	ILLINOIS	FED. AID PROJECT		
* 068-1919.2-CF			CONTRACT 60371	

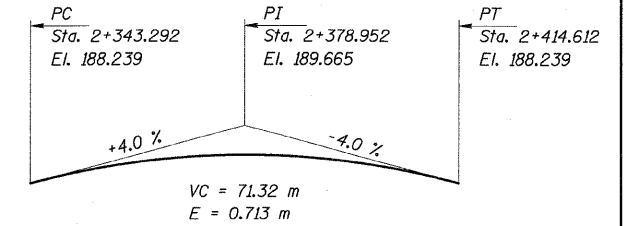

PROFILE GRADE 115TH STREET  
(Along  $\bar{C}$  115th Street)

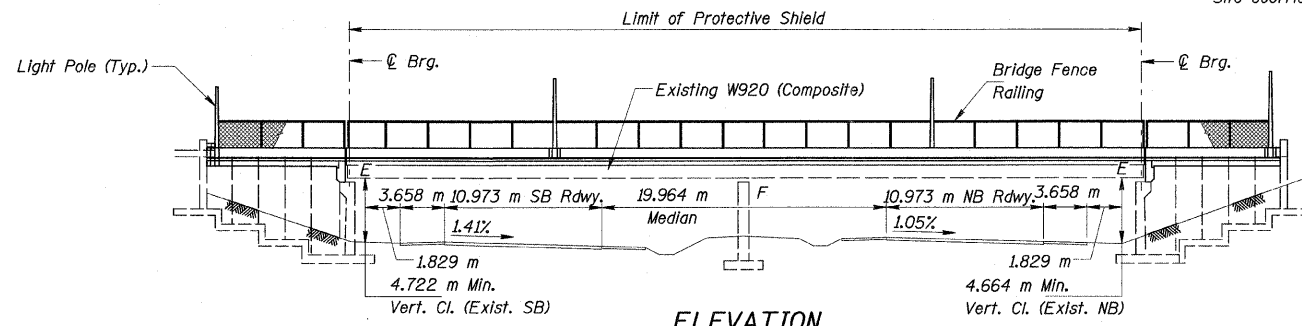

ELEVATION

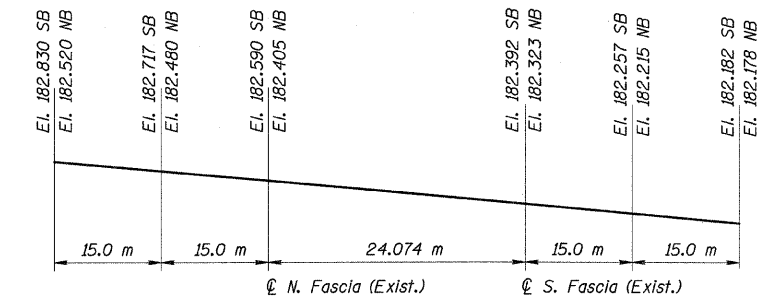

(MAX.) TOP OF PAVEMENT EDGE ELEVATIONS  
(I-57 Outside Edge of Pavement)

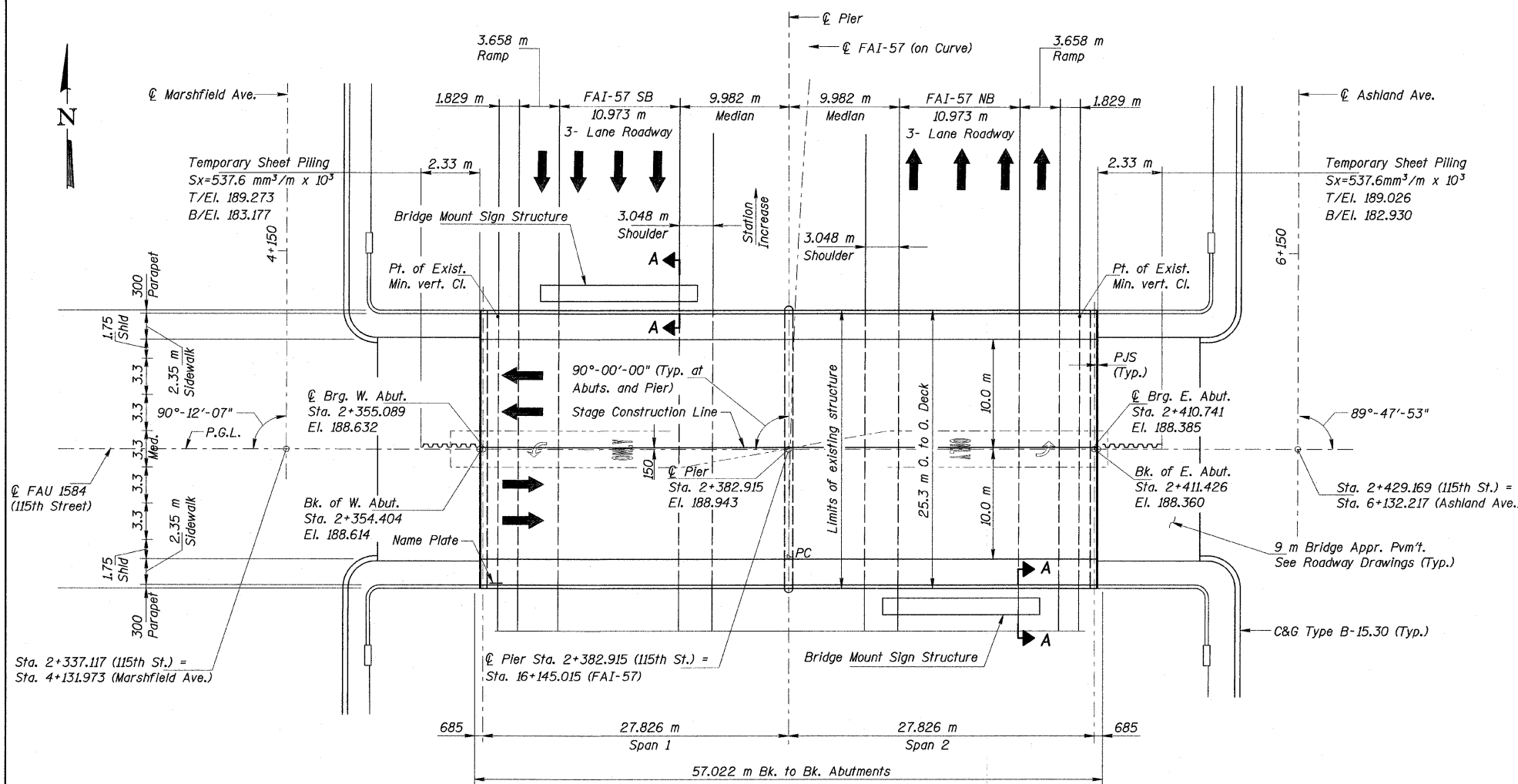

PLAN

STATION 2+382.915  
RE-BUILT 200 BY  
STATE OF ILLINOIS  
F.A.U. RT. 1584 SEC 068-1919.2-CF  
LOADING MS18  
STR. NO. 016-2037

**NAME PLATE**

See Std. 515001  
Clean and relocate existing name plate adjacent to new name plate. Cost included with name plates.

Vertical clearance shall be verified by Contractor prior to construction. This work shall not be measured for payment and shall be included in the cost for Construction Layout.

Notes:  
Protective shield is currently in place. Contractor shall remove and deliver protective shield to IDOT District One Bridge Office. See note on sheet S2.

For Section A-A see Bridge Mounted Sign Structure Connection Details on sheet No. S23 of S23.

**APPROVED**  
FOR STRUCTURAL ADEQUACY ONLY

Robert E. Anderson (TJD)  
ENGINEER OF BRIDGES AND STRUCTURES



REVISIONS	
NAME	DATE

ILLINOIS DEPARTMENT OF TRANSPORTATION  
115 TH. STREET OVER FAI 57  
FAU RTE. 1584 SEC. 068-1919.2-CF  
COOK COUNTY  
STATION 2+382.915  
STRUCTURE NO. 016-2037

**GENERAL PLAN & ELEVATION**

DRAWN BY KAC  
CHECKED BY ERB/DGS

DATE JANUARY 16, 2009

**COLLINS ENGINEERS**  
123 North Wacker Drive  
Suite 300  
Chicago, IL 60606  
(312) 704-9300  
www.collinsengr.com  
ILLINOIS PROFESSIONAL DESIGN FIRM LICENSE NO. 184-000993

**GENERAL NOTES:**

Fasteners shall be AASHTO M164 Type I, mechanically galvanized bolts.  
Bolts M20, open holes 22 mm diameter, unless otherwise noted.

Calculated mass of structural steel: AASHTO M 270M Grade 250 = 6,520 kg

No field welding is permitted except as specified in the contract documents.

The structural steel bearing plates of the Elastomeric Bearing Assembly shall conform to the requirements of AASHTO M 270M Grade 345.

Reinforcement bars shall conform to the requirements of ASTM A706 Gr. 420 (IL Modified). See Special Provisions.

Reinforcement bars designated (E) shall be epoxy coated.

Plan dimensions and details relative to existing structure have been taken from existing plans and are subject to nominal construction variations. It shall be the Contractor's responsibility to verify such dimensions and details in the field and make necessary approved adjustments prior to construction or ordering of materials. Such variations shall not be cause for additional compensation for a change in the scope of the work, however, the Contractor will be paid for the quantity actually furnished at the unit price bid for the work.

All dimensions are in millimeters (mm) except as noted.

The existing structural steel coating contains lead. The Contractor should take appropriate precautions to deal with the presence of lead on this project.

If the Contractor chooses to alter the temporary sheet piling design requirements shown on the plans for lesser design requirements, then full design submittals with the required seals will be expected by the Department, for review and approval.

The back face of Closed Abutments and their wingwalls shall be waterproofed according to Article 503.18 of the Standard Specifications.

Prior to pouring the new concrete for the deck, all loose rust, loose mill scale and all other loose, detrimental foreign material shall be removed from the portions of flanges of beams in contact with concrete. Tightly adhered paint may remain unless otherwise noted. This removal shall be accomplished by methods that will not damage the steel and the cost of this work will be included in the pay item covering removal of the existing concrete.

As directed by the Engineer, existing construction accessories welded to the top flange of beams and girders shall be removed. The weld areas shall be ground flush and inspected for cracks Dye penetrant (PT), magnetic particle (MT), or other approved testing method shall be performed by a qualified personnel approved by the Engineer. Any cracks that can not be removed by grinding 6mm deep shall be identified and reported to the Bureau of Bridges and Structures for further disposition. The cost of removing welded accessories, grinding and inspecting weld areas and grinding cracks will be paid for according to Article 109.04 of the Standard Specifications.

The Contractor shall test the welds within 600 mm of the end of the existing cover plates for cracks after removal of the existing concrete deck. Dye penetrant, magnetic particle, or other approved testing method shall be performed by personnel approved by the Engineer. If cracks are found, report them to the Bureau of Bridges and Structures for further processing. The cost of testing is included in Removal of Existing Concrete Deck. The cost of crack repair, if necessary, will be paid according to Article 109.04 of the Standard Specifications.

Field painting of structural steel shall be done under a separate painting contract, except as noted below.

Existing structural steel shall only be cleaned and painted as required by the special provision "Cleaning and Painting Contract Surface Areas of Existing Steel Structures."

All new structural steel shall be shop painted with an Inorganic zinc rich primer per AASHTO M 300, Type 1.

The existing bridge rail shall be salvaged and delivered to the District One Maintenance Yard. The address to deliver the bridge rail to is: IDOT District One Bridge Office, 1101 Blesterfield Road, Elk Grove, IL 60007, Telephone: (847) 956-1501. A 24 hour notice should be given before delivery. The cost for this work shall be included in Removal of Existing Concrete Deck.

**TOTAL BILL OF MATERIAL**

ITEM	UNIT	SUPER	SUB	TOTAL
Concrete Removal	m <sup>3</sup>	—	30.3	30.3
Removal of Existing Concrete Deck	Each	1	—	1
Structural Steel Removal	kg	3,140	—	3,140
Structure Excavation	m <sup>3</sup>	—	136	136
Porous Granular Embankment (Special)	m <sup>3</sup>	—	86	86
Preformed Joint Strip Seal	m	50.9	—	50.9
Concrete Structures	m <sup>3</sup>	—	24.8	24.8
Concrete Superstructure	m <sup>3</sup>	477.7	—	477.7
Bridge Deck Grooving	m <sup>2</sup>	1,087	—	1,087
Protective Coat	m <sup>2</sup>	1,577	—	1,577
Elastomeric Bearing Assembly, Type I	Each	28	—	28
Furnishing and Erecting Structural Steel	kg	6,520	—	6,520
Bridge Fence Railing	m	145.5	—	145.5
Reinforcement Bars, Epoxy Coated	kg	52,500	4,100	56,600
Name Plates	Each	1	—	1
Epoxy Crack Injection	m	—	70	70
Jack and Remove Existing Bearings	Each	28	—	28
Protective Shield	m <sup>2</sup>	1,475	—	1,475
Bar Splicers	Each	690	24	714
Structural Repair of Concrete (Depth =< 125mm)	m <sup>2</sup>	—	43	43
Temporary Sheet Piling	m <sup>2</sup>	—	28.4	28.4
Remove, Store and Re-Erect Overhead Sign Structure Bridge Mounted	Each	2	—	2
Removal of Asbestos Cement Conduit	Meter	228	—	228
Concrete Sealer	m <sup>2</sup>	—	37	37

Care should be taken when removing the existing hardwood and protective shielding. All the hardwood shall be salvaged and delivered to the District One Maintenance Yard. The address to deliver the hardwood protective shield to is: IDOT District One Bridge Office, 1101 Blesterfield Road, Elk Grove, IL 60007, Telephone: (847) 956-1501. A 24 hour notice should be given before delivery. Existing non-hardwood protective shield shall be removed and disposed of. Minor adjustments to the protective shield system may be required. See Specifications for more information.

The cost of maintaining, adjusting, salvaging, delivering and/or disposing of existing protective shielding shall be included with Protective Shielding. See Specifications for more information.

Slip-Forming of the parapets is not allowed.

Concrete sealer shall be applied to exposed areas of the back wall.

ROUTE NO.	SECTION	COUNTY	TOTAL SHEETS	SHEET NO.	SHEET NO. S2
FAU 1584	A	COOK	119	75	S23 SHEETS
FED. ROAD DIST. NO. 7	ILLINOIS	FED. AID PROJECT-			
A068-1919.2-CF			CONTRACT 60371		

**LIST OF STRUCTURAL DRAWINGS**

TITLE	SHEET
General Plan And Elevation	S1
General Notes & Bill of Material	S2
Staged Construction Sections	S3
Top of Slab Elevations-I	S4
Top of Slab Elevations-II	S5
Top of Slab Elevations-III	S6
Superstructure	S7
Superstructure Details-I	S8
Superstructure Details-II	S9
Superstructure Details-III	S10
Bridge Fence Railing	S11
Framing Plan	S12
Bearing Details	S13
West Abutment Removal	S14
West Abutment Details-I	S15
West Abutment Details-II	S16
East Abutment Removal	S17
East Abutment Details-I	S18
East Abutment Details-II	S19
Anchor Bolt Details For Bearings	S20
Bar Splicer Details	S21
Temporary Concrete Barrier	S22
Bridge Mount Sign Structure Connection Details	S23

REVISIONS	
NAME	DATE

**COLLINS ENGINEERS**  
123 North Wacker Drive  
Suite 300  
Chicago, IL 60606  
(312) 704-9300  
www.collinsengr.com  
ILLINOIS PROFESSIONAL DESIGN FIRM LICENSE NO. 184-000993

ILLINOIS DEPARTMENT OF TRANSPORTATION  
115 TH. STREET OVER FAI 57  
FAU RTE. 1584 SEC. 068-1919.2-CF  
COOK COUNTY  
STATION 2+382.915  
STRUCTURE NO. 016-2037  
**GENERAL NOTES & BILL OF MATERIAL**  
DRAWN BY KAC  
CHECKED BY ERB/DGS  
DATE JANUARY 16, 2009

ROUTE NO.	SECTION	COUNTY	TOTAL SHEETS	SHEET NO.	SHEET NO. S3
FAU 1584		COOK	119	76	S23 SHEETS
FED. ROAD DIST. NO. 7		ILLINOIS	FED. AID PROJECT		
068-1919.2-CF		CONTRACT 60371			

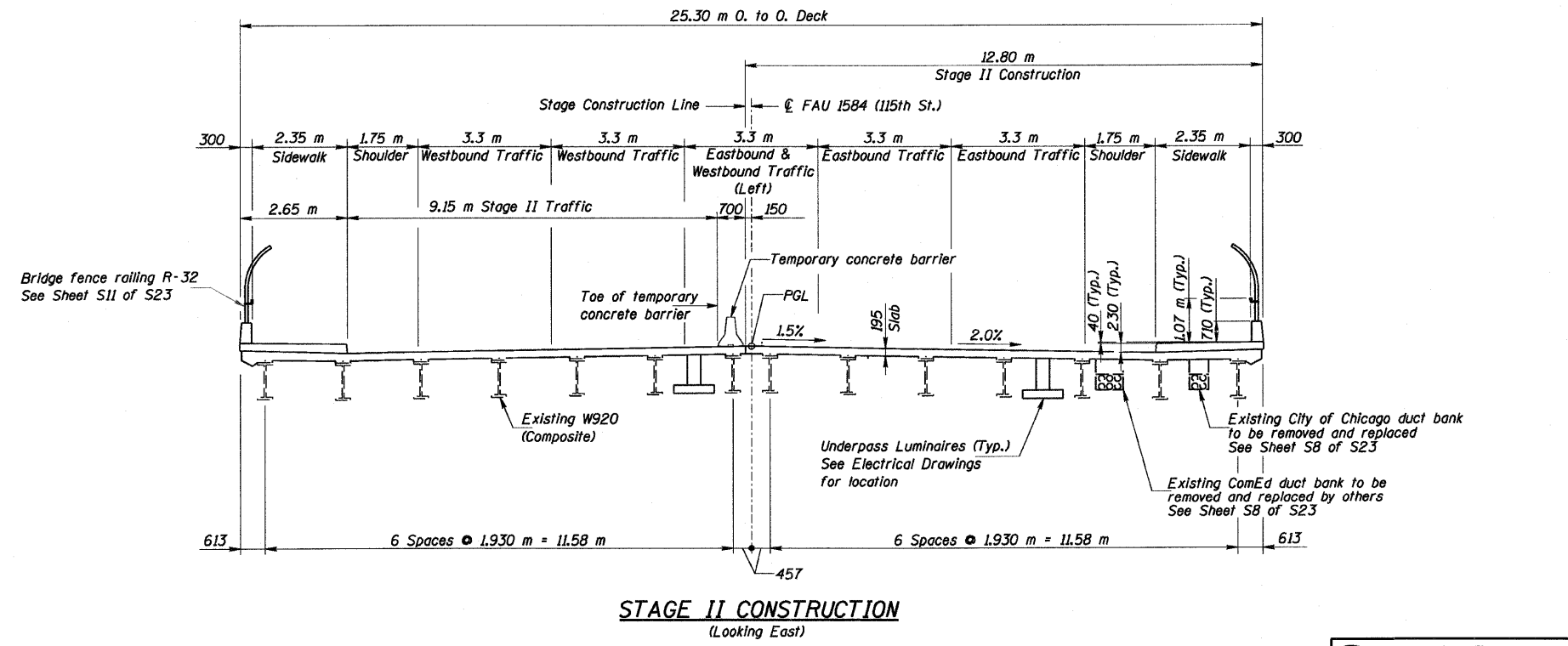
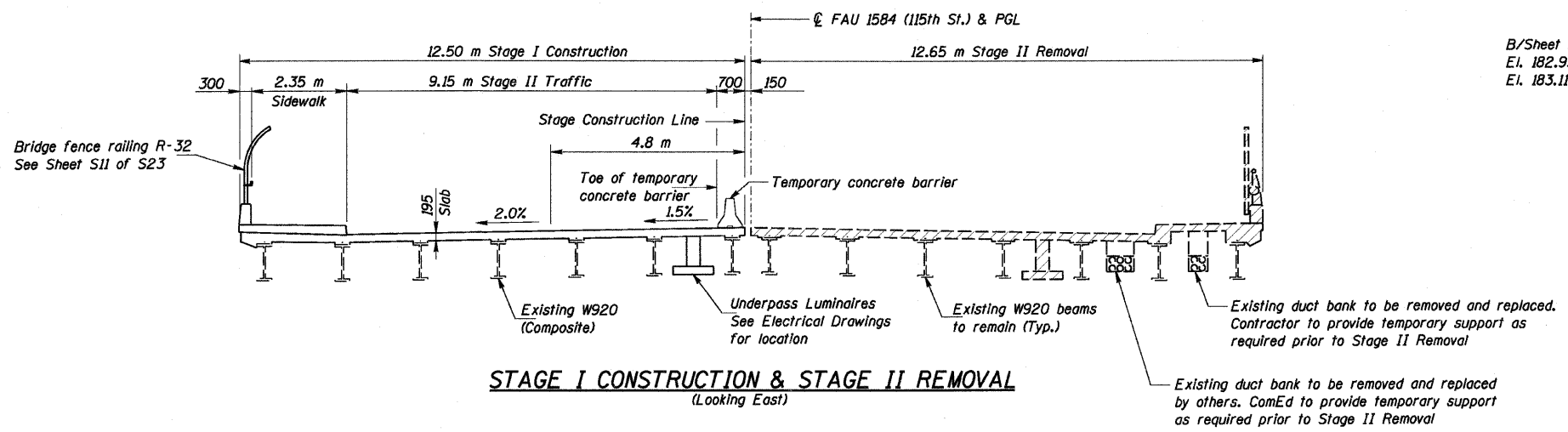
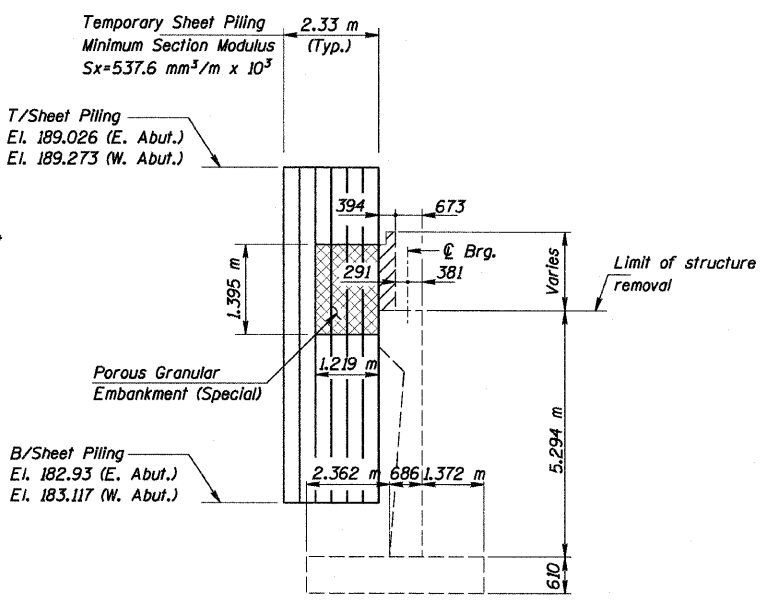
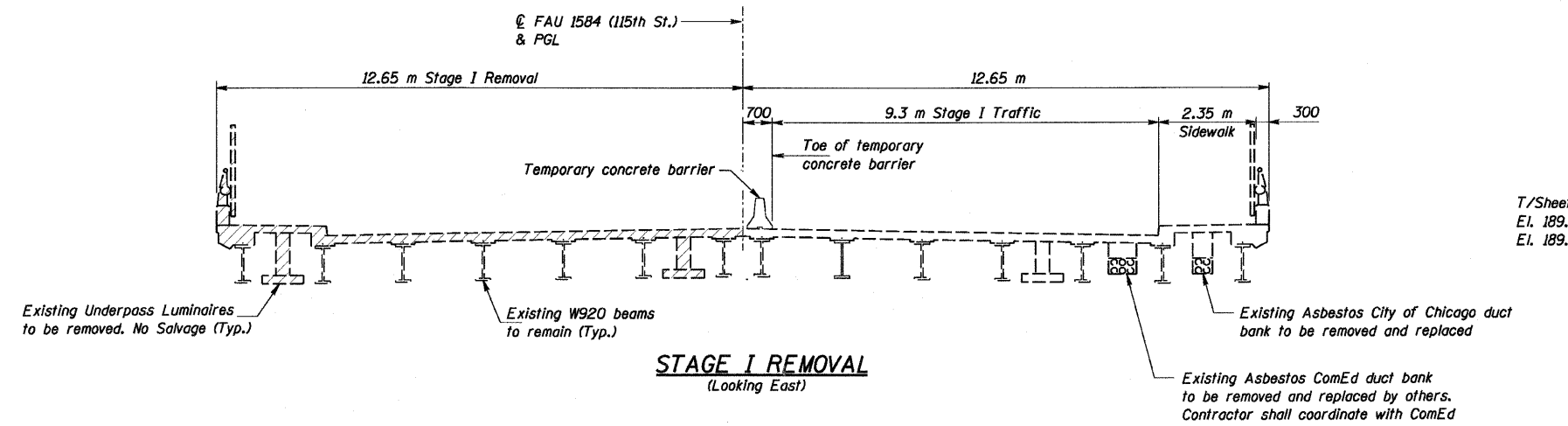

Notes:

- See general notes for more information regarding existing and proposed protective shielding.
- Hatched area indicates removal of Existing Concrete Deck.
- Steel superstructure location to remain the same.
- All dimensions are in millimeters (mm) except as noted.
- For quantity of temporary concrete barrier, see Roadway Plans.
- For details of temporary concrete barrier, see Sheet S22 of S23.

REVISIONS		ILLINOIS DEPARTMENT OF TRANSPORTATION 115 TH. STREET OVER FAI 57 FAU RTE. 1584 SEC. 068-1919.2-CF COOK COUNTY STATION 2+382.915 STRUCTURE NO. 016-2037
NAME	DATE	
		<b>STAGED CONSTRUCTION SECTIONS</b> DRAWN BY TMC CHECKED BY ERB/DGS DATE: JANUARY 16, 2009

**COLLINS ENGINEERS**  
123 North Wacker Drive  
Suite 300  
Chicago, IL 60606  
(312) 704-9300  
www.collinsengr.com  
ILLINOIS PROFESSIONAL DESIGN FIRM LICENSE NO. 184-008993

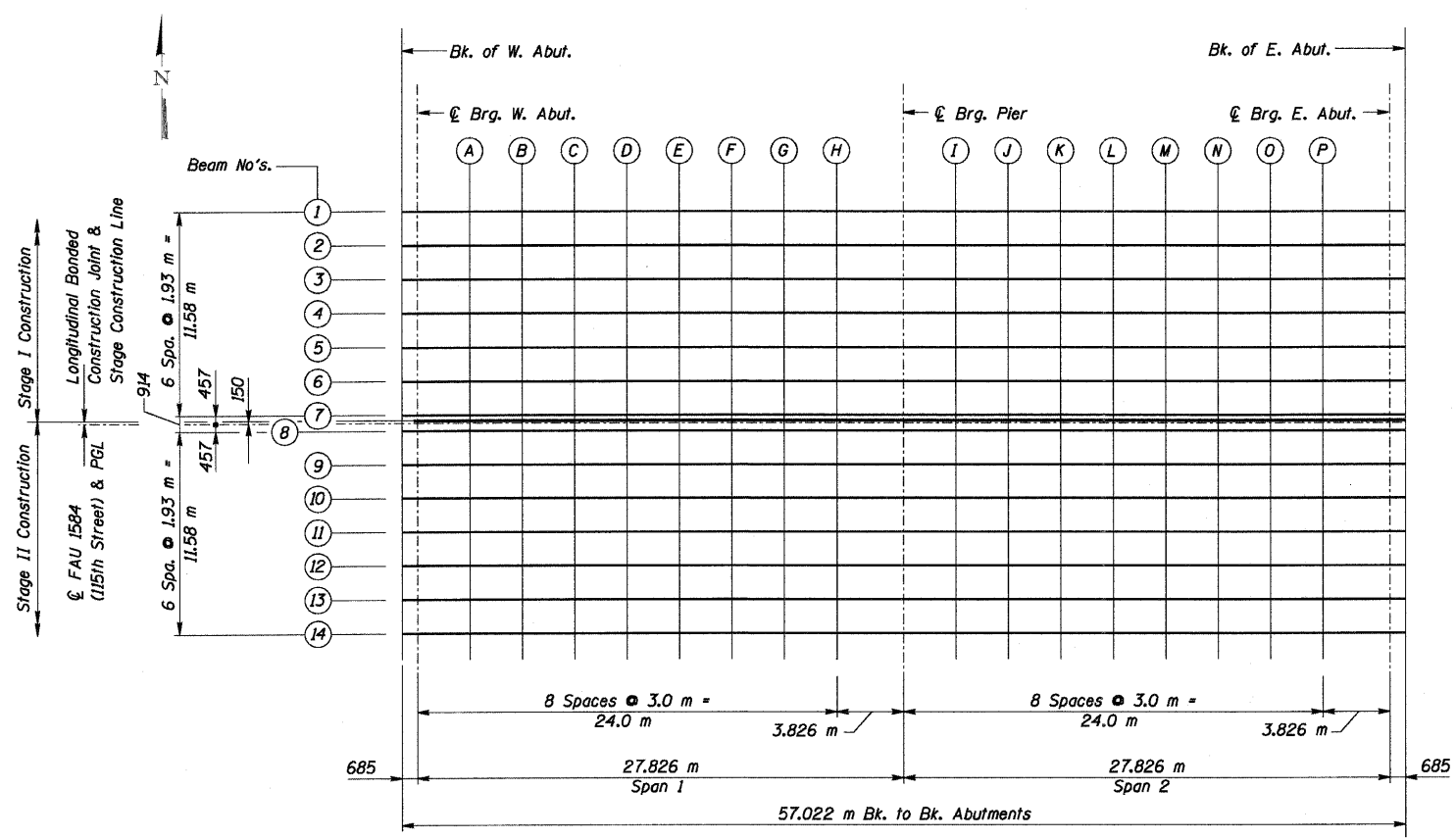

**PLAN**

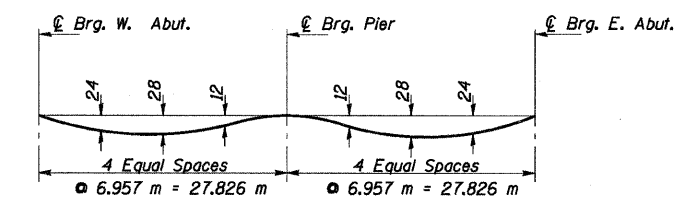

**DEAD LOAD DEFLECTION DIAGRAM**  
(Includes weight of concrete only)

**Notes:**  
The above deflections are not to be used in the field if the engineer is working from the grade elevations adjusted for the dead load deflections as shown on this sheet and on Sheets S5 and S6 of S23.  
All dimensions are in millimeters (mm) except as noted.  
All elevations and offsets are in meters.

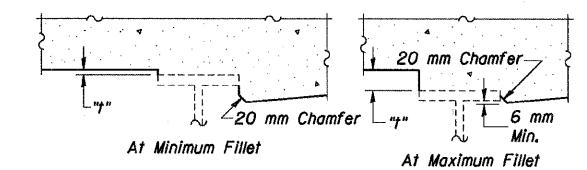

To determine "f": After all structural steel has been erected, elevations of the top flanges of the beams shall be taken at intervals shown on this sheet. These elevations subtracted from the "Theoretical Grade Elevations Adjusted for Dead Load Deflection" shown on this sheet and on Sheets S5 and S6 of S23, minus slab thickness, equals the fillet heights "f" above top flange of beams.

**FILLET HEIGHTS**

**BEAM 1**

Location	Station	Offset	Theoretical Grade Elevations	Theoretical Grade Elevations Adjusted For Dead Load Deflection
Bk. of W. Abut.	2354.404	12.037	188.398	188.398
C Brg. W. Abut.	2355.089	12.037	188.416	188.416
A	2358.089	12.037	188.492	188.504
B	2361.089	12.037	188.557	188.578
C	2364.089	12.037	188.612	188.639
D	2367.089	12.037	188.657	188.686
E	2370.089	12.037	188.692	188.718
F	2373.089	12.037	188.717	188.736
G	2376.089	12.037	188.731	188.743
H	2379.089	12.037	188.736	188.740
C Brg. Pier	2382.915	12.037	188.727	188.727
I	2385.915	12.037	188.709	188.711
J	2388.915	12.037	188.680	188.690
K	2391.915	12.037	188.642	188.659
L	2394.915	12.037	188.593	188.617
M	2397.915	12.037	188.534	188.562
N	2400.915	12.037	188.465	188.493
O	2403.915	12.037	188.386	188.410
P	2406.915	12.037	188.297	188.312
C Brg. E. Abut.	2410.741	12.037	188.169	188.169
Bk. of E. Abut.	2411.426	12.037	188.144	188.144

**BEAM 2**

Location	Station	Offset	Theoretical Grade Elevations	Theoretical Grade Elevations Adjusted For Dead Load Deflection
Bk. of W. Abut.	2354.404	10.107	188.436	188.436
C Brg. W. Abut.	2355.089	10.107	188.455	188.455
A	2358.089	10.107	188.530	188.542
B	2361.089	10.107	188.595	188.617
C	2364.089	10.107	188.651	188.678
D	2367.089	10.107	188.695	188.724
E	2370.089	10.107	188.730	188.756
F	2373.089	10.107	188.755	188.775
G	2376.089	10.107	188.770	188.782
H	2379.089	10.107	188.774	188.779
C Brg. Pier	2382.915	10.107	188.766	188.766
I	2385.915	10.107	188.747	188.750
J	2388.915	10.107	188.719	188.728
K	2391.915	10.107	188.680	188.698
L	2394.915	10.107	188.631	188.656
M	2397.915	10.107	188.573	188.601
N	2400.915	10.107	188.504	188.532
O	2403.915	10.107	188.425	188.448
P	2406.915	10.107	188.336	188.351
C Brg. E. Abut.	2410.741	10.107	188.208	188.208
Bk. of E. Abut.	2411.426	10.107	188.183	188.183

**BEAM 3**

Location	Station	Offset	Theoretical Grade Elevations	Theoretical Grade Elevations Adjusted For Dead Load Deflection
Bk. of W. Abut.	2354.404	8.177	188.475	188.475
C Brg. W. Abut.	2355.089	8.177	188.494	188.494
A	2358.089	8.177	188.569	188.581
B	2361.089	8.177	188.634	188.656
C	2364.089	8.177	188.689	188.716
D	2367.089	8.177	188.734	188.763
E	2370.089	8.177	188.769	188.795
F	2373.089	8.177	188.794	188.813
G	2376.089	8.177	188.808	188.820
H	2379.089	8.177	188.813	188.818
C Brg. Pier	2382.915	8.177	188.804	188.804
I	2385.915	8.177	188.786	188.789
J	2388.915	8.177	188.757	188.767
K	2391.915	8.177	188.719	188.736
L	2394.915	8.177	188.670	188.695
M	2397.915	8.177	188.611	188.640
N	2400.915	8.177	188.542	188.571
O	2403.915	8.177	188.464	188.487
P	2406.915	8.177	188.374	188.389
C Brg. E. Abut.	2410.741	8.177	188.246	188.246
Bk. of E. Abut.	2411.426	8.177	188.222	188.222

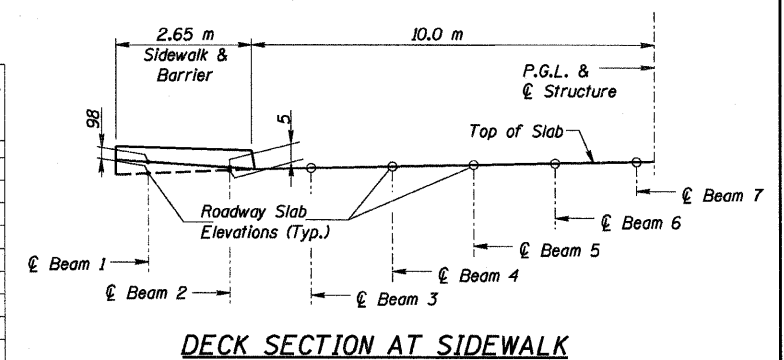

**DECK SECTION AT SIDEWALK**

**Notes:**  
Work this sheet with Sheets S5 and S6 of S23.

**COLLINS ENGINEERS**  
123 North Wacker Drive  
Suite 300  
Chicago, IL 60606  
(312) 704-9300  
www.collinsengr.com  
ILLINOIS PROFESSIONAL DESIGN FIRM LICENSE NO. 184-00093

REVISIONS	
NAME	DATE

ILLINOIS DEPARTMENT OF TRANSPORTATION  
115 TH. STREET OVER FAI 57  
FAU RTE. 1584 SEC. 068-1919.2-CF  
COOK COUNTY  
STATION 2+382.915  
STRUCTURE NO. 016-2037  
**TOP OF SLAB ELEVATIONS-1**  
DRAWN BY KAC  
CHECKED BY FRB/DGS  
DATE: JANUARY 16, 2009

**BEAM 4**

Location	Station	Offset	Theoretical Grade Elevations	Theoretical Grade Elevations Adjusted For Dead Load Deflection
Bk. of W. Abut.	2354.404	6.247	188.514	188.514
¢ Brg. W. Abut.	2355.089	6.247	188.532	188.532
A	2358.089	6.247	188.607	188.619
B	2361.089	6.247	188.673	188.694
C	2364.089	6.247	188.728	188.755
D	2367.089	6.247	188.773	188.801
E	2370.089	6.247	188.808	188.833
F	2373.089	6.247	188.832	188.852
G	2376.089	6.247	188.847	188.859
H	2379.089	6.247	188.852	188.856
¢ Brg. Pier	2382.915	6.247	188.843	188.843
I	2385.915	6.247	188.824	188.827
J	2388.915	6.247	188.796	188.805
K	2391.915	6.247	188.757	188.775
L	2394.915	6.247	188.709	188.733
M	2397.915	6.247	188.650	188.678
N	2400.915	6.247	188.581	188.609
O	2403.915	6.247	188.502	188.525
P	2406.915	6.247	188.413	188.428
¢ Brg. E. Abut.	2410.741	6.247	188.285	188.285
Bk. of E. Abut.	2411.426	6.247	188.260	188.260

**BEAM 5**

Location	Station	Offset	Theoretical Grade Elevations	Theoretical Grade Elevations Adjusted For Dead Load Deflection
Bk. of W. Abut.	2354.404	4.317	188.549	188.549
¢ Brg. W. Abut.	2355.089	4.317	188.568	188.568
A	2358.089	4.317	188.643	188.655
B	2361.089	4.317	188.708	188.730
C	2364.089	4.317	188.763	188.790
D	2367.089	4.317	188.808	188.837
E	2370.089	4.317	188.843	188.869
F	2373.089	4.317	188.868	188.887
G	2376.089	4.317	188.882	188.894
H	2379.089	4.317	188.887	188.892
¢ Brg. Pier	2382.915	4.317	188.878	188.878
I	2385.915	4.317	188.860	188.863
J	2388.915	4.317	188.831	188.841
K	2391.915	4.317	188.793	188.810
L	2394.915	4.317	188.744	188.769
M	2397.915	4.317	188.685	188.714
N	2400.915	4.317	188.617	188.645
O	2403.915	4.317	188.538	188.561
P	2406.915	4.317	188.448	188.463
¢ Brg. E. Abut.	2410.741	4.317	188.320	188.320
Bk. of E. Abut.	2411.426	4.317	188.296	188.296

**BEAM 6**

Location	Station	Offset	Theoretical Grade Elevations	Theoretical Grade Elevations Adjusted For Dead Load Deflection
Bk. of W. Abut.	2354.404	2.387	188.578	188.578
¢ Brg. W. Abut.	2355.089	2.387	188.597	188.597
A	2358.089	2.387	188.672	188.684
B	2361.089	2.387	188.737	188.758
C	2364.089	2.387	188.792	188.819
D	2367.089	2.387	188.837	188.866
E	2370.089	2.387	188.872	188.898
F	2373.089	2.387	188.897	188.916
G	2376.089	2.387	188.911	188.923
H	2379.089	2.387	188.916	188.921
¢ Brg. Pier	2382.915	2.387	188.907	188.907
I	2385.915	2.387	188.889	188.892
J	2388.915	2.387	188.860	188.870
K	2391.915	2.387	188.822	188.839
L	2394.915	2.387	188.773	188.798
M	2397.915	2.387	188.714	188.743
N	2400.915	2.387	188.645	188.673
O	2403.915	2.387	188.566	188.590
P	2406.915	2.387	188.477	188.492
¢ Brg. E. Abut.	2410.741	2.387	188.349	188.349
Bk. of E. Abut.	2411.426	2.387	188.325	188.325

ROUTE NO.	SECTION	COUNTY	TOTAL SHEETS	SHEET NO.
FAU 1584	A	COOK	119	78
FED. ROAD DIST. NO. 7	ILLINOIS	FED. AID PROJECT-		
A068-1919.2-CF			CONTRACT 60371	

SHEET NO. 55  
S23 SHEETS

**BEAM 7**

Location	Station	Offset	Theoretical Grade Elevations	Theoretical Grade Elevations Adjusted For Dead Load Deflection
Bk. of W. Abut.	2354.404	0.457	188.607	188.607
¢ Brg. W. Abut.	2355.089	0.457	188.626	188.626
A	2358.089	0.457	188.701	188.713
B	2361.089	0.457	188.766	188.787
C	2364.089	0.457	188.821	188.848
D	2367.089	0.457	188.866	188.895
E	2370.089	0.457	188.901	188.927
F	2373.089	0.457	188.926	188.945
G	2376.089	0.457	188.940	188.952
H	2379.089	0.457	188.945	188.949
¢ Brg. Pier	2382.915	0.457	188.936	188.936
I	2385.915	0.457	188.918	188.921
J	2388.915	0.457	188.889	188.899
K	2391.915	0.457	188.851	188.868
L	2394.915	0.457	188.802	188.827
M	2397.915	0.457	188.743	188.772
N	2400.915	0.457	188.674	188.702
O	2403.915	0.457	188.595	188.619
P	2406.915	0.457	188.506	188.521
¢ Brg. E. Abut.	2410.741	0.457	188.378	188.378
Bk. of E. Abut.	2411.426	0.457	188.353	188.353

**STAGE CONSTRUCTION LINE & LONGITUDINAL CONSTRUCTION JOINT**

Location	Station	Offset	Theoretical Grade Elevations	Theoretical Grade Elevations Adjusted For Dead Load Deflection
Bk. of W. Abut.	2354.404	0.150	188.612	188.612
¢ Brg. W. Abut.	2355.089	0.150	188.630	188.630
A	2358.089	0.150	188.705	188.717
B	2361.089	0.150	188.771	188.792
C	2364.089	0.150	188.826	188.853
D	2367.089	0.150	188.871	188.899
E	2370.089	0.150	188.905	188.931
F	2373.089	0.150	188.930	188.950
G	2376.089	0.150	188.945	188.957
H	2379.089	0.150	188.950	188.954
¢ Brg. Pier	2382.915	0.150	188.941	188.941
I	2385.915	0.150	188.922	188.925
J	2388.915	0.150	188.894	188.903
K	2391.915	0.150	188.855	188.873
L	2394.915	0.150	188.807	188.831
M	2397.915	0.150	188.748	188.776
N	2400.915	0.150	188.679	188.707
O	2403.915	0.150	188.600	188.623
P	2406.915	0.150	188.511	188.526
¢ Brg. E. Abut.	2410.741	0.150	188.383	188.383
Bk. of E. Abut.	2411.426	0.150	188.358	188.358

**¢ ROADWAY & PROFILE GRADE LINE**

Location	Station	Offset	Theoretical Grade Elevations	Theoretical Grade Elevations Adjusted For Dead Load Deflection
Bk. of W. Abut.	2354.404	0.000	188.614	188.614
¢ Brg. W. Abut.	2355.089	0.000	188.632	188.632
A	2358.089	0.000	188.708	188.720
B	2361.089	0.000	188.773	188.794
C	2364.089	0.000	188.828	188.855
D	2367.089	0.000	188.873	188.902
E	2370.089	0.000	188.908	188.934
F	2373.089	0.000	188.933	188.952
G	2376.089	0.000	188.947	188.959
H	2379.089	0.000	188.952	188.956
¢ Brg. Pier	2382.915	0.000	188.943	188.943
I	2385.915	0.000	188.925	188.927
J	2388.915	0.000	188.896	188.906
K	2391.915	0.000	188.858	188.875
L	2394.915	0.000	188.809	188.833
M	2397.915	0.000	188.750	188.778
N	2400.915	0.000	188.681	188.709
O	2403.915	0.000	188.602	188.626
P	2406.915	0.000	188.513	188.528
¢ Brg. E. Abut.	2410.741	0.000	188.385	188.385
Bk. of E. Abut.	2411.426	0.000	188.360	188.360

**BEAM 8**

Location	Station	Offset	Theoretical Grade Elevations	Theoretical Grade Elevations Adjusted For Dead Load Deflection
Bk. of W. Abut.	2354.404	0.457	188.607	188.607
¢ Brg. W. Abut.	2355.089	0.457	188.626	188.626
A	2358.089	0.457	188.701	188.713
B	2361.089	0.457	188.766	188.787
C	2364.089	0.457	188.821	188.848
D	2367.089	0.457	188.866	188.895
E	2370.089	0.457	188.901	188.927
F	2373.089	0.457	188.926	188.945
G	2376.089	0.457	188.940	188.952
H	2379.089	0.457	188.945	188.949
¢ Brg. Pier	2382.915	0.457	188.936	188.936
I	2385.915	0.457	188.918	188.921
J	2388.915	0.457	188.889	188.899
K	2391.915	0.457	188.851	188.868
L	2394.915	0.457	188.802	188.827
M	2397.915	0.457	188.743	188.772
N	2400.915	0.457	188.674	188.702
O	2403.915	0.457	188.595	188.619
P	2406.915	0.457	188.506	188.521
¢ Brg. E. Abut.	2410.741	0.457	188.378	188.378
Bk. of E. Abut.	2411.426	0.457	188.353	188.353

**BEAM 9**

Location	Station	Offset	Theoretical Grade Elevations	Theoretical Grade Elevations Adjusted For Dead Load Deflection
Bk. of W. Abut.	2354.404	2.387	188.578	188.578
¢ Brg. W. Abut.	2355.089	2.387	188.597	188.597
A	2358.089	2.387	188.672	188.684
B	2361.089	2.387	188.737	188.758
C	2364.089	2.387	188.792	188.819
D	2367.089	2.387	188.837	188.866
E	2370.089	2.387	188.872	188.898
F	2373.089	2.387	188.897	188.916
G	2376.089	2.387	188.911	188.923
H	2379.089	2.387	188.916	188.921
¢ Brg. Pier	2382.915	2.387	188.907	188.907
I	2385.915	2.387	188.889	188.892
J	2388.915	2.387	188.860	188.870
K	2391.915	2.387	188.822	188.839
L	2394.915	2.387	188.773	188.798
M	2397.915	2.387	188.714	188.743
N	2400.915	2.387	188.645	188.673
O	2403.915	2.387	188.566	188.590
P	2406.915	2.387	188.477	188.492
¢ Brg. E. Abut.	2410.741	2.387	188.349	188.349
Bk. of E. Abut.	2411.426	2.387	188.325	188.325

Note:  
Work this sheet with Sheets S4 and S6 of S23.

REVISIONS	
NAME	DATE

ILLINOIS DEPARTMENT OF TRANSPORTATION  
115 TH. STREET OVER FAI 57  
FAU RTE. 1584 SEC. 068-1919.2-CF  
COOK COUNTY  
STATION 2+382.915  
STRUCTURE NO. 016-2037  
**TOP OF SLAB ELEVATIONS-II**

DRAWN BY MDK  
CHECKED BY ERB/DGS  
DATE: JANUARY 16, 2009

**COLLINS ENGINEERS**  
123 North Wacker Drive  
Suite 300  
Chicago, IL 60606  
(312) 704-9300  
www.collinseng.com  
ILLINOIS PROFESSIONAL DESIGN FIRM LICENSE NO. 184-06993

BEAM 10

Table with 5 columns: Location, Station, Offset, Theoretical Grade Elevations, Theoretical Grade Elevations Adjusted For Dead Load Deflection. Rows include Bk. of W. Abut., C. Brq. W. Abut., and various pier locations A through P.

BEAM 11

Table with 5 columns: Location, Station, Offset, Theoretical Grade Elevations, Theoretical Grade Elevations Adjusted For Dead Load Deflection. Rows include Bk. of W. Abut., C. Brq. W. Abut., and various pier locations A through P.

BEAM 12

Table with 5 columns: Location, Station, Offset, Theoretical Grade Elevations, Theoretical Grade Elevations Adjusted For Dead Load Deflection. Rows include Bk. of W. Abut., C. Brq. W. Abut., and various pier locations A through P.

Summary table with columns: ROUTE NO., SECTION, COUNTY, TOTAL SHEETS, SHEET NO., SHEET NO. 56, S23 SHEETS.

BEAM 13

Table with 5 columns: Location, Station, Offset, Theoretical Grade Elevations, Theoretical Grade Elevations Adjusted For Dead Load Deflection. Rows include Bk. of W. Abut., C. Brq. W. Abut., and various pier locations A through P.

BEAM 14

Table with 5 columns: Location, Station, Offset, Theoretical Grade Elevations, Theoretical Grade Elevations Adjusted For Dead Load Deflection. Rows include Bk. of W. Abut., C. Brq. W. Abut., and various pier locations A through P.

Note: Work this sheet with Sheets S4 and S5 of S23.



Table with columns: REVISIONS (NAME, DATE), ILLINOIS DEPARTMENT OF TRANSPORTATION, 115 TH. STREET OVER FAI 57, FAU RTE. 1584 SEC. 068-1919.2-CF, COOK COUNTY, STATION 2+382.915, STRUCTURE NO. 016-2037, TOP OF SLAB ELEVATIONS-III, DRAWN BY MDK, CHECKED BY ERB/DGS, DATE: JANUARY 16, 2009

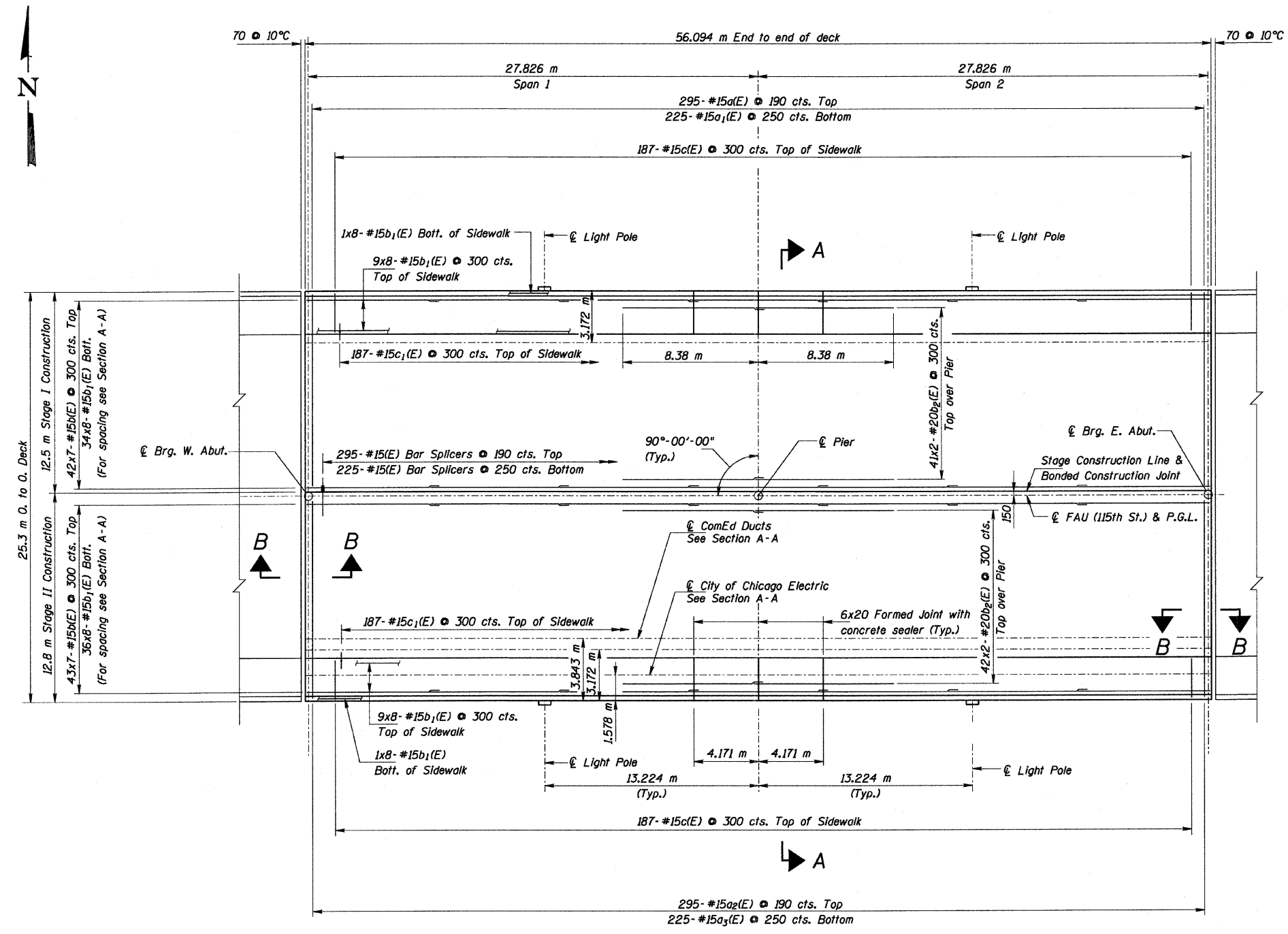

**PLAN**

Minimum Bar Laps  
 #15 Bars = 640  
 #20 Bars = 790

Notes:  
 Bars indicated thus 20x3-#15 etc. indicates 20 lines of bars with 3 lengths per line.  
 All dimensions are in millimeters (mm) except as noted.  
 See Sheet S8 of S23 for Sections A-A & B-B.  
 See Sheet S10 of S23 for parapet reinforcement and Bill of Materials.

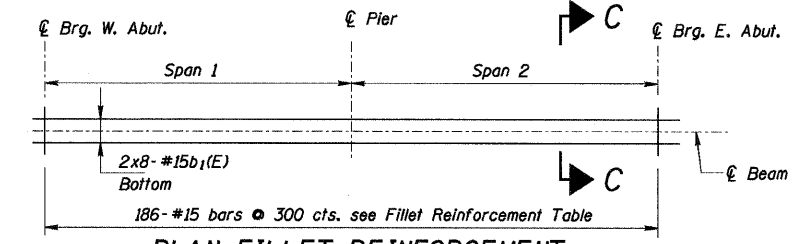

**PLAN-FILLET REINFORCEMENT**

Note:  
 Fillet s bars are placed from West Abutment to Pier 1 and from Pier 1 to East Abutment in the order shown in the Table.

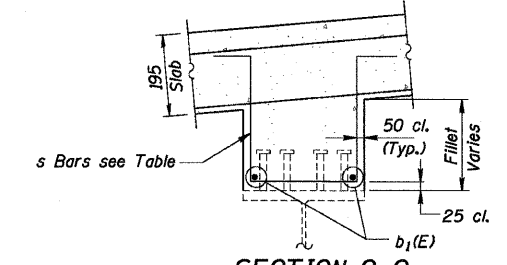

**SECTION C-C**

**FILLET REINFORCEMENT TABLE**

Beam	Location	
	Span 1	Span 2
1	20- #15s1(E), 49- #15s1(E) & 24- #15s1(E)	93- #15s1(E)
2	20- #15s2(E), 49- #15s3(E) & 24- #15s2(E)	93- #15s2(E)
3	20- #15s4(E), 49- #15s5(E) & 24- #15s4(E)	93- #15s4(E)
4	20- #15s6(E), 49- #15s7(E) & 24- #15s9(E)	93- #15s9(E)
5	20- #15s9(E), 49- #15s10(E) & 24- #15s9(E)	30- #15s9(E), 50- #15s3(E) & 13- #15s9(E)
6	20- #15s9(E), 49- #15s4(E) & 24- #15s5(E)	30- #15s9(E), 50- #15s3(E) & 13- #15s9(E)
7	50- #15s9(E), 37- #15s4(E) & 6- #15s5(E)	30- #15s5(E), 50- #15s8(E) & 13- #15s9(E)
8	69- #15s1(E), 11- #15s4(E) & 13- #15s9(E)	30- #15s5(E), 40- #15s8(E) & 23- #15s1(E)
9	20- #15s9(E), 49- #15s10(E) & 24- #15s9(E)	30- #15s9(E), 50- #15s3(E) & 13- #15s9(E)
10	20- #15s9(E), 49- #15s10(E) & 24- #15s9(E)	30- #15s9(E), 50- #15s3(E) & 13- #15s9(E)
11	20- #15s6(E), 49- #15s10(E) & 24- #15s6(E)	47- #15s6(E), 30- #15s10(E) & 16- #15s6(E)
12	20- #15s4(E), 49- #15s3(E) & 24- #15s4(E)	50- #15s4(E), 20- #15s3(E) & 23- #15s4(E)
13	20- #15s11(E), 49- #15s3(E) & 24- #15s11(E)	70- #15s11(E) & 23- #15s2(E)
14	20- #15s1(E), 49- #15s1(E) & 24- #15s1(E)	93- #15s5(E)

REVISIONS	
NAME	DATE

ILLINOIS DEPARTMENT OF TRANSPORTATION  
 115 TH. STREET OVER FAI 57  
 FAU RTE. 1584 SEC. 068-1919.2-CF  
 COOK COUNTY  
 STATION 2+382.915  
 STRUCTURE NO. 016-2037  
**SUPERSTRUCTURE**  
 DRAWN BY KAC  
 CHECKED BY FRB/DGS  
 DATE: JANUARY 16, 2009

**COLLINS ENGINEERS**  
 123 North Wacker Drive  
 Suite 300  
 Chicago, IL 60606  
 (312) 704-9300  
 www.collinsengr.com  
 ILLINOIS PROFESSIONAL DESIGN FIRM LICENSE NO. 184-080993



ROUTE NO.	SECTION	COUNTY	TOTAL SHEETS	SHEET NO.
FAU 1584		COOK	119	81
FED. ROAD DIST. NO. 7		ILLINOIS FED. AID PROJECT		
068-1919.2-CF		CONTRACT 60371		

SHEET NO. 58  
S23 SHEETS

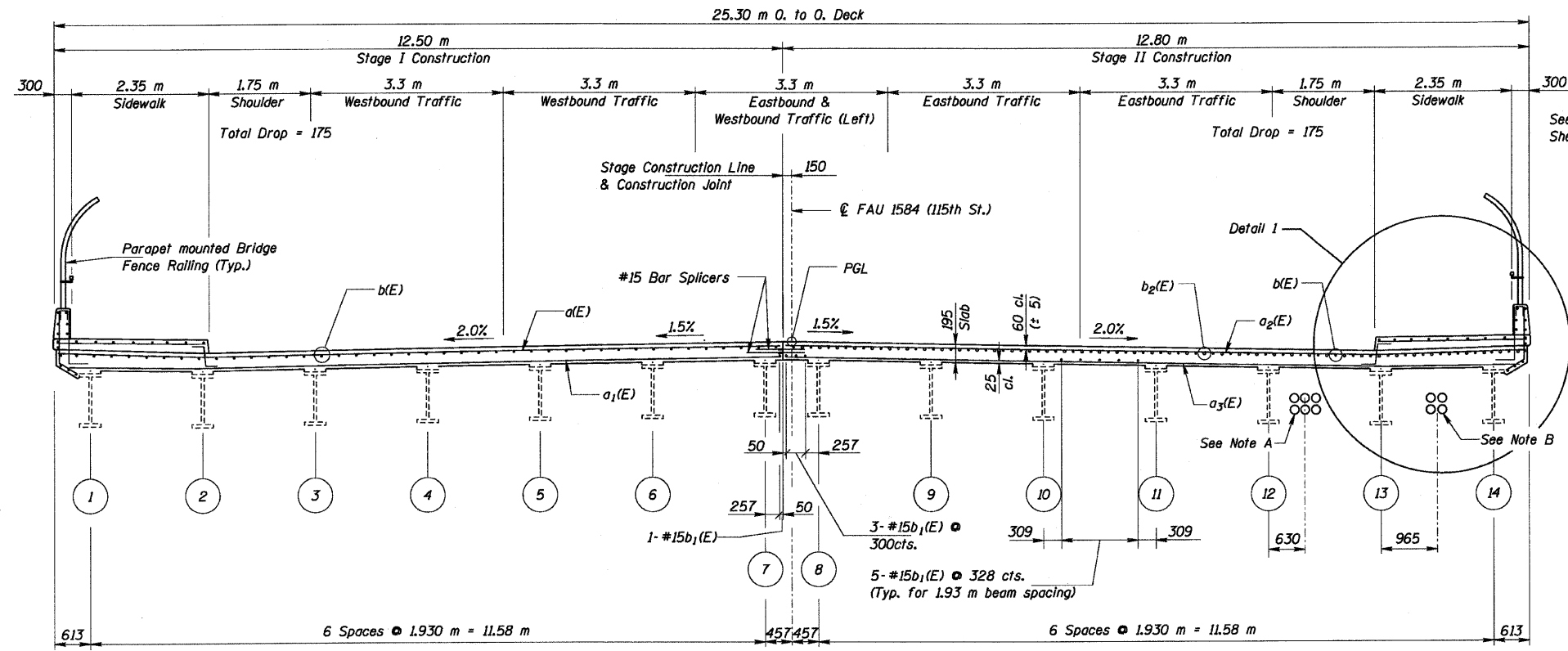

**SECTION A-A**  
(Looking East)

**Note A:**  
6-100  $\phi$  Ducts to be removed and replaced by others. ComEd to provide temporary support prior to Stage II Removal. Hangers and inserts in new bridge deck per ComEd requirements. Inserts are to be furnished and placed by the Contractor. This work shall be included in the cost of Concrete Superstructure bid item.

**Note B:**  
90  $\phi$  Ducts to be removed and replaced with 75  $\phi$  Ducts. Contractor to provide temporary support prior to Stage II Removal. Hangers, inserts and ducts in new bridge deck per City of Chicago Electric requirements. Inserts, hangers and ducts are to be furnished and placed by the Contractor. This work shall be included in the cost of Concrete Superstructure bid item.

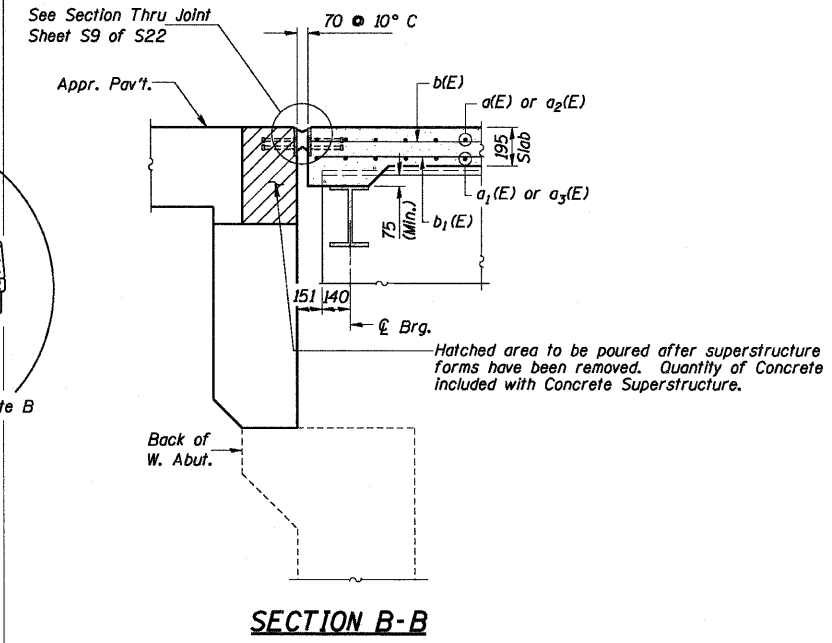

**SECTION B-B**

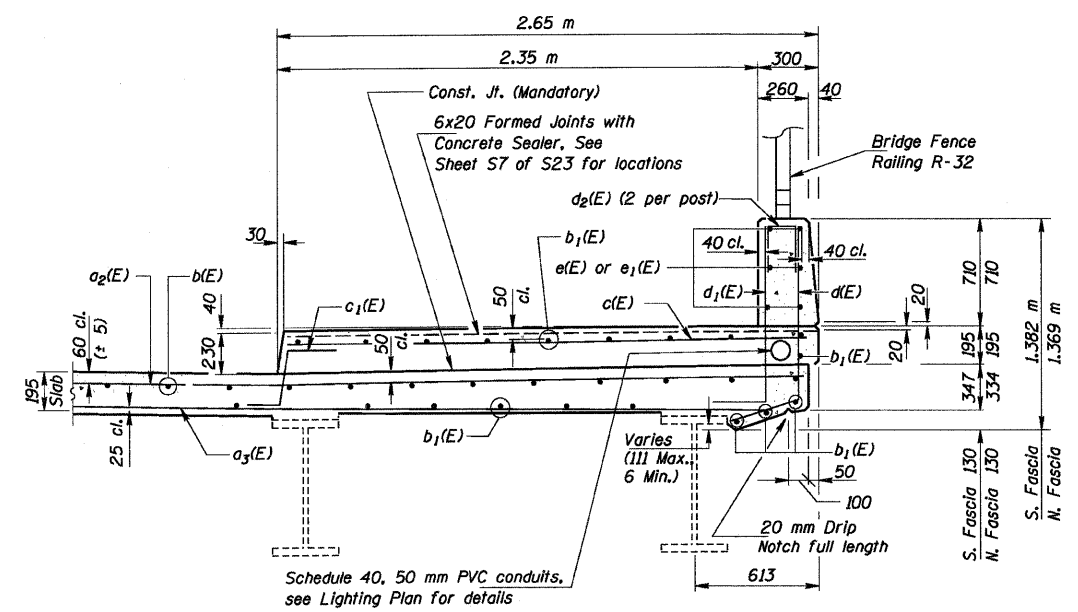

**DETAIL I**

**Notes:**  
All dimensions are in millimeters (mm) except as noted. See Sheet S10 of S23 for Bill of Materials. See Electrical Drawings for Underpass Luminaire location and attachment details to deck.

REVISIONS	
NAME	DATE

ILLINOIS DEPARTMENT OF TRANSPORTATION  
115 TH. STREET OVER FAI 57  
FAU RTE. 1584 SEC. 068-1919.2-CF  
COOK COUNTY  
STATION 2+382.915  
STRUCTURE NO. 016-2037  
**SUPERSTRUCTURE DETAILS-1**  
DRAWN BY KAC  
CHECKED BY FRB/DGS  
DATE: JANUARY 16, 2009

**COLLINS ENGINEERS**  
123 North Wacker Drive  
Suite 300  
Chicago, IL 60606  
(312) 704-9300  
www.collinsengr.com  
ILLINOIS PROFESSIONAL DESIGN FIRM LICENSE NO. 194-090993

\*Granular or solid flux filled headed studs conforming to Article 1006.32 of the Std. Specs., automatically end welded.

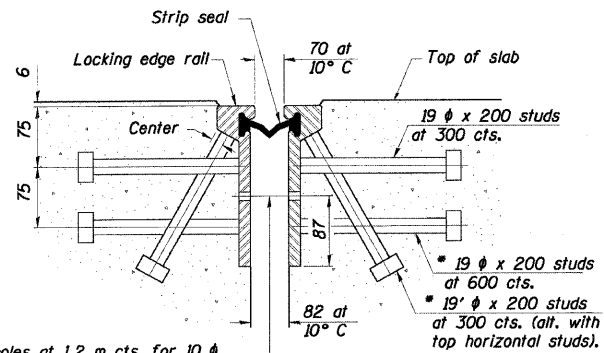

12 φ holes at 1.2 m cts. for 10 φ bolts. All bolts shall be burned, sawed, or chipped off flush with the plates after forms are removed, typ.

**SECTION THRU  
ROLLED RAIL JOINT**

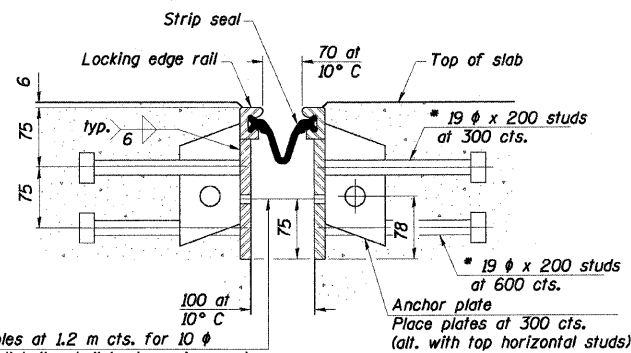

12 φ holes at 1.2 m cts. for 10 φ bolts. All bolts shall be burned, sawed, or chipped off flush with the plates after forms are removed, typ.

**SECTION THRU  
WELDED RAIL JOINT**

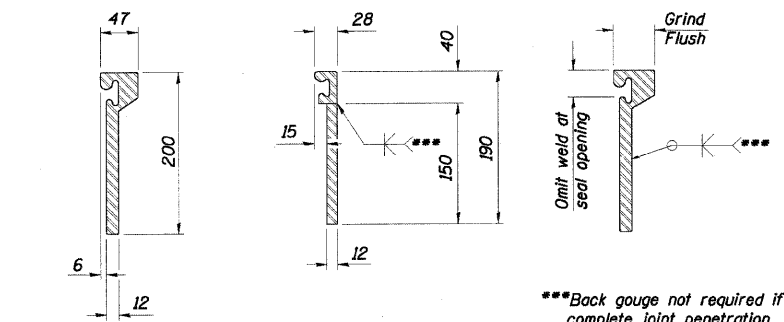

**ROLLED  
(EXTRUDED) RAIL    WELDED RAIL**

**LOCKING EDGE  
RAIL SPLICE**

The inside of the locking edge rail groove shall be free of weld residue.

**LOCKING EDGE RAILS**

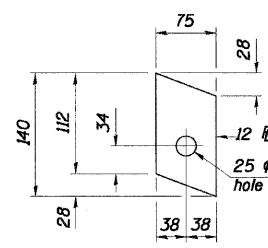

**ANCHOR PLATE  
(for welded rail)**

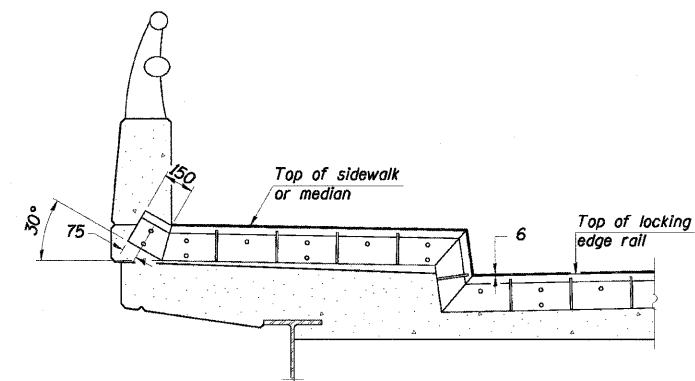

**AT SIDEWALK OR MEDIAN**

Shorter plates with a single row of studs at 300 mm cts. may be necessary on medians which are shallower than 225 mm. See manufacturer's recommendation.

**TYPICAL END TREATMENTS**

**BILL OF MATERIAL**

Item	Unit	Total
Preformed Joint Strip Seal	Meter	50.9

**PREFORMED JOINT STRIP SEAL**

REVISIONS	
NAME	DATE

ILLINOIS DEPARTMENT OF TRANSPORTATION  
115 TH. STREET OVER FAI 57  
FAU RTE. 1584 SEC. 068-1919.2-CF  
COOK COUNTY  
STATION 2+382.915  
STRUCTURE NO. 016-2037

**SUPERSTRUCTURE DETAILS-II**

DRAWN BY KAC  
CHECKED BY ERB/DGS      DATE: JANUARY 16, 2009

**COLLINS ENGINEERS**  
123 North Wacker Drive  
Suite 300  
Chicago, IL 60606  
(312) 704-9300  
www.collinseng.com  
ILLINOIS PROFESSIONAL DESIGN FIRM LICENSE NO. 184-000993

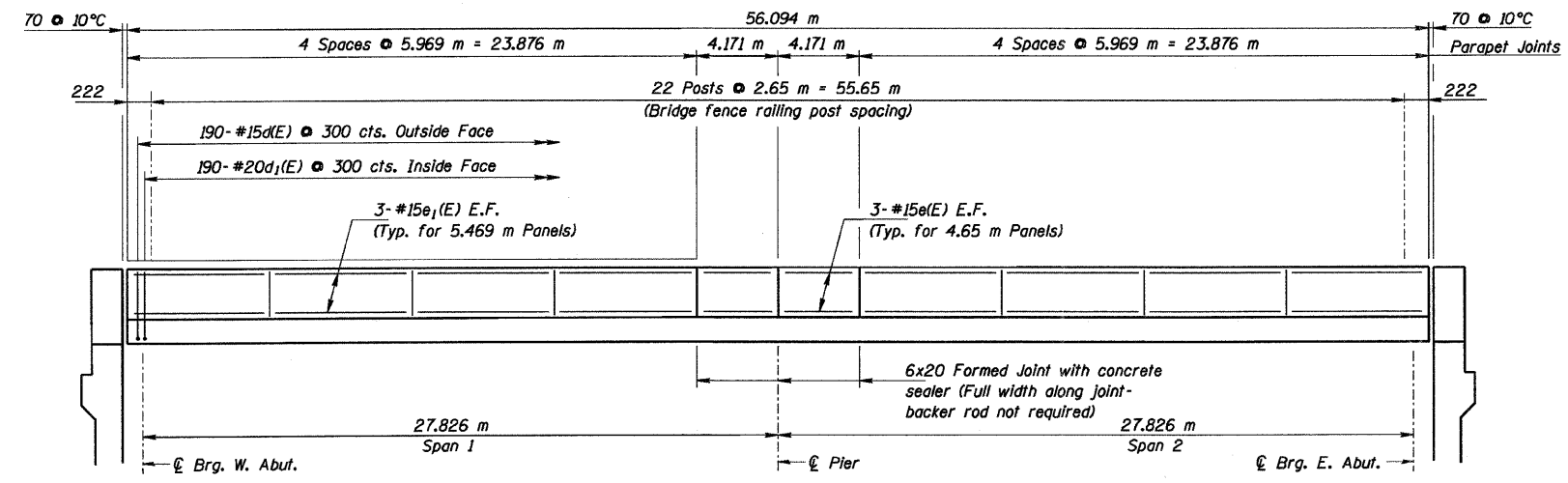

**INSIDE ELEVATION OF PARAPET**

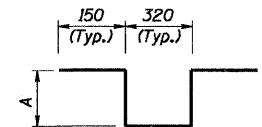

BAR	A
s(E)	120
s <sub>1</sub> (E)	220
s <sub>2</sub> (E)	150
s <sub>3</sub> (E)	270
s <sub>4</sub> (E)	170
s <sub>5</sub> (E)	290
s <sub>6</sub> (E)	185
s <sub>7</sub> (E)	310
s <sub>8</sub> (E)	320
s <sub>9</sub> (E)	205
s <sub>10</sub> (E)	300
s <sub>11</sub> (E)	160

**SUPERSTRUCTURE BILL OF MATERIAL**

BAR	NO.	SIZE	LENGTH (m)	SHAPE	
d(E)	295	#15	12.35	—	
a <sub>1</sub> (E)	225	#15	12.15	—	
a <sub>2</sub> (E)	295	#15	12.50	—	
a <sub>3</sub> (E)	225	#15	12.30	—	
a <sub>4</sub> (E)	128	#15	0.60	—	
b(E)	595	#15	8.56	—	
b <sub>1</sub> (E)	944	#15	7.57	—	
b <sub>2</sub> (E)	166	#20	8.78	—	
c(E)	374	#15	2.50	—	
c <sub>1</sub> (E)	374	#15	0.73	—	
d(E)	380	#15	1.39	—	
d <sub>1</sub> (E)	380	#20	1.31	—	
d <sub>2</sub> (E)	88	#15	0.61	—	
d <sub>3</sub> (E)	12	#20	1.41	—	
d <sub>4</sub> (E)	20	#20	2.68	—	
e(E)	24	#15	4.07	—	
e <sub>1</sub> (E)	96	#15	5.87	—	
s(E)	181	#15	0.86	—	
s <sub>1</sub> (E)	190	#15	1.06	—	
s <sub>2</sub> (E)	160	#15	0.92	—	
s <sub>3</sub> (E)	367	#15	1.16	—	
s <sub>4</sub> (E)	351	#15	0.96	—	
s <sub>5</sub> (E)	245	#15	1.20	—	
s <sub>6</sub> (E)	127	#15	0.99	—	
s <sub>7</sub> (E)	49	#15	1.24	—	
s <sub>8</sub> (E)	90	#15	1.26	—	
s <sub>9</sub> (E)	504	#15	1.03	—	
s <sub>10</sub> (E)	226	#15	1.22	—	
s <sub>11</sub> (E)	114	#15	0.94	—	
Reinforcement Bars, Epoxy Coated				kg	52,500
Concrete Superstructure				m <sup>3</sup>	453.6

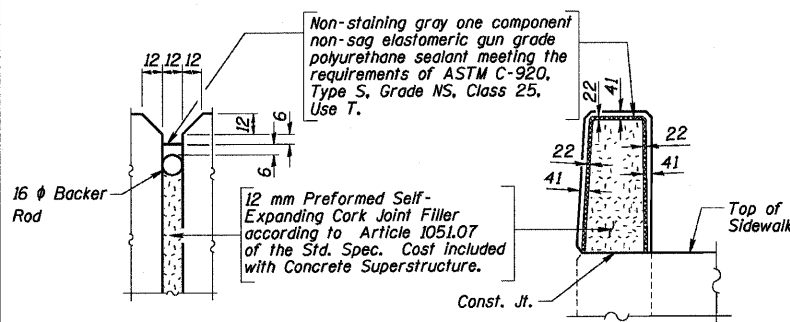

**PARAPET JOINT DETAILS**

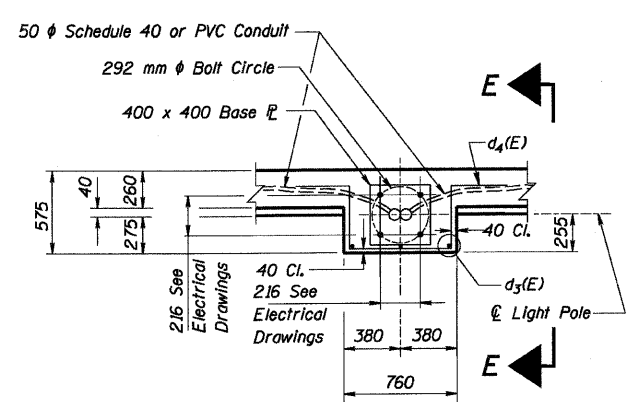
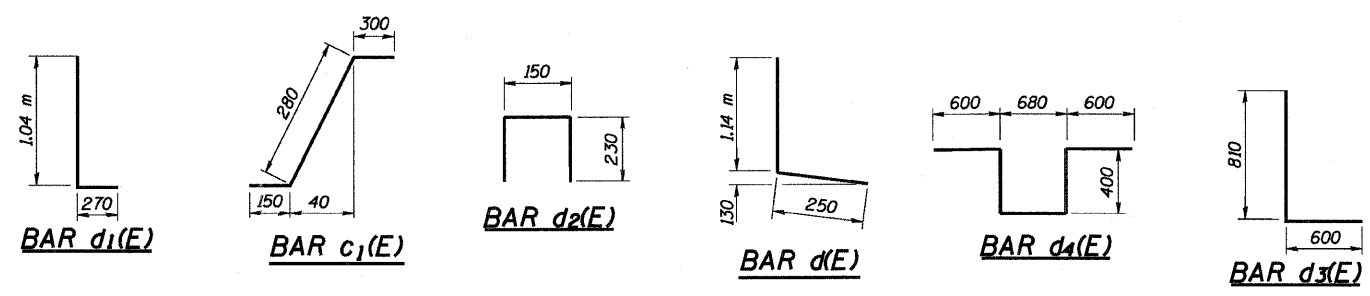

**LIGHT POLE PLAN**

Note:  
JDOT Standard Details have been modified to comply with CDOT Standards.

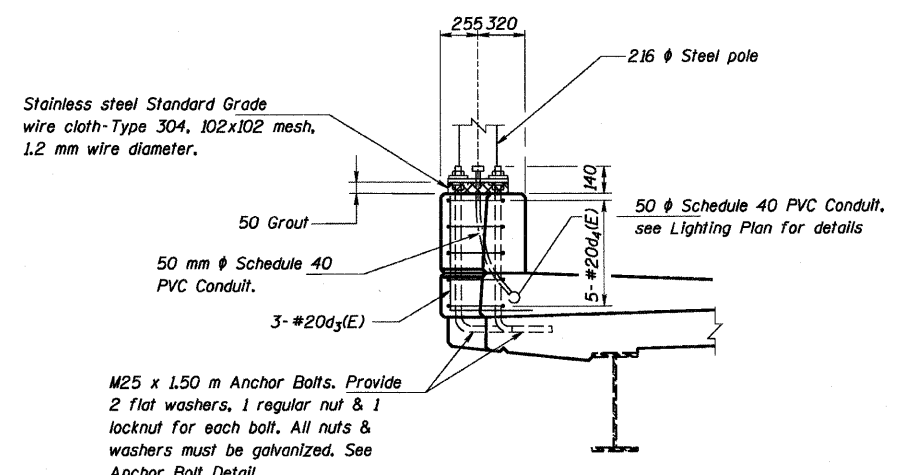

**SECTION E-E**

Note:  
Grout mixture shall consist of 1 part sand, 1 part cement and 1 part chips (pea gravel). The grout shall contain water for a 25 slump, cost incidental to pole.  
Cost of anchor bolts and conduit is included with Concrete Superstructure.

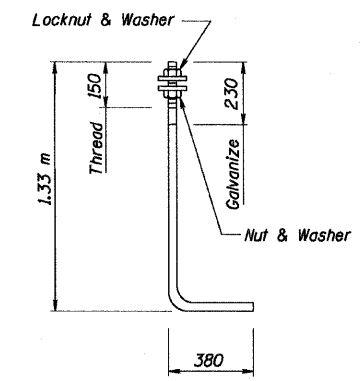

**M25 ANCHOR BOLT**

Minimum Bar Laps  
#15 Bars = 640

**COLLINS ENGINEERS**  
123 North Wacker Drive  
Chicago, IL 60606  
(312) 704-9300  
www.collinsengr.com  
ILLINOIS PROFESSIONAL DESIGN FIRM LICENSE NO. 184-008993

REVISIONS	
NAME	DATE

ILLINOIS DEPARTMENT OF TRANSPORTATION  
115 TH. STREET OVER FAI 57  
FAU RTE. 1584 SEC. 068-1919.2-CF  
COOK COUNTY  
STATION 2+382.915  
STRUCTURE NO. 016-2037

**SUPERSTRUCTURE DETAILS-III**

DRAWN BY KAC  
CHECKED BY ERB/DGS  
DATE: JANUARY 16, 2009

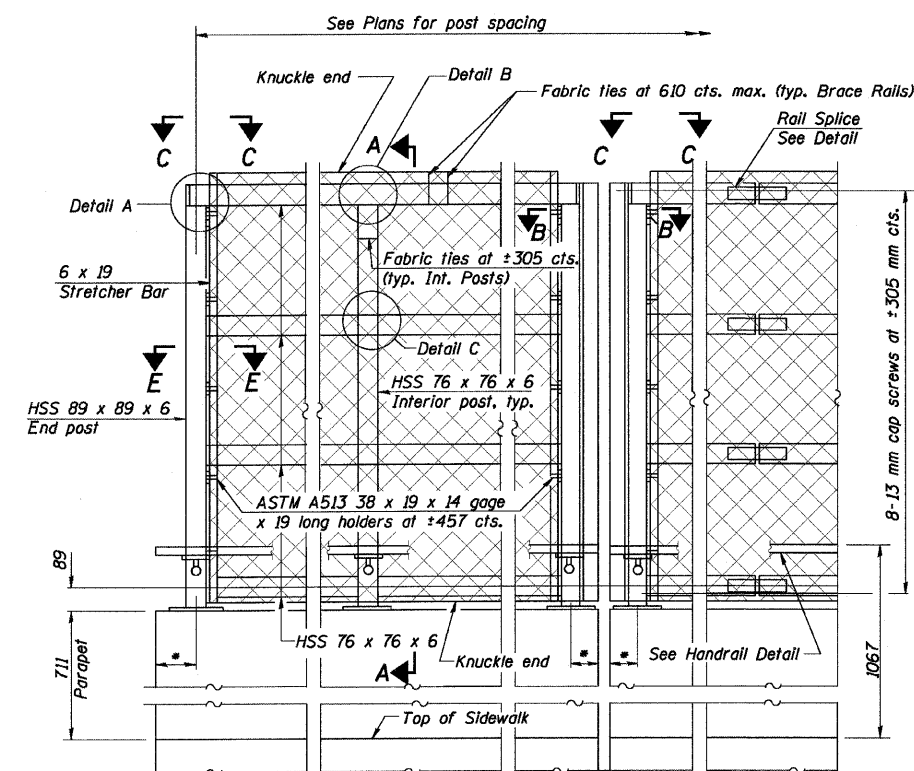

**ELEVATION**  
(Inside Face)

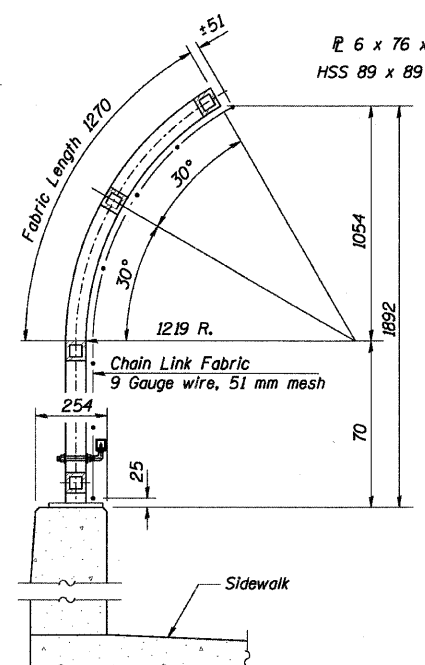

**SECTION A-A**

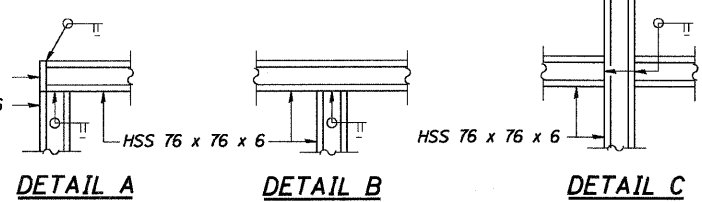

**DETAIL A**      **DETAIL B**      **DETAIL C**

Notes:  
All steel rail elements shall be galvanized according to Article 509.05 of the Standard Specifications.  
Contractor shall provide clearance for Re-Installation of the bridge mounted sign. Modifications may also be required for access to the street lighting. All cutouts and any other required modifications shall be included in the pay item for Bridge Fence Railing.

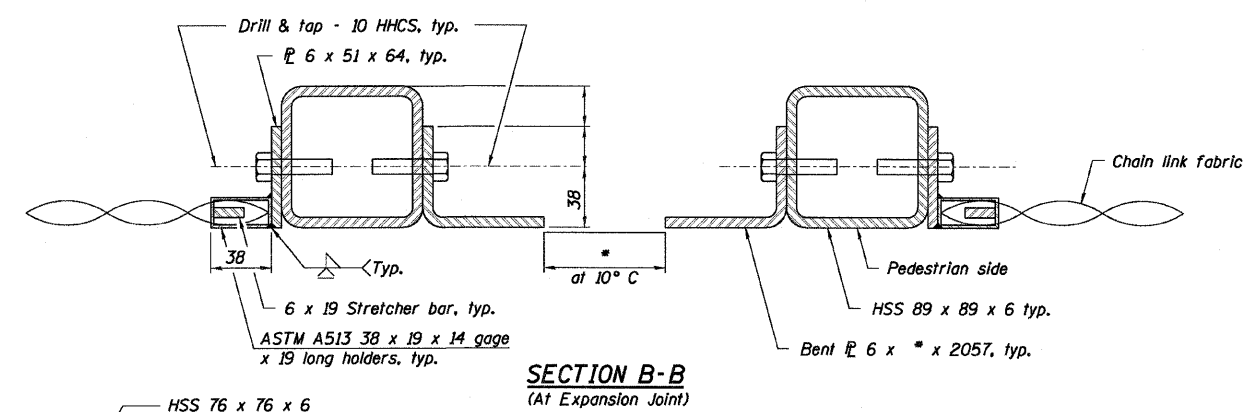

**SECTION B-B**  
(At Expansion Joint)

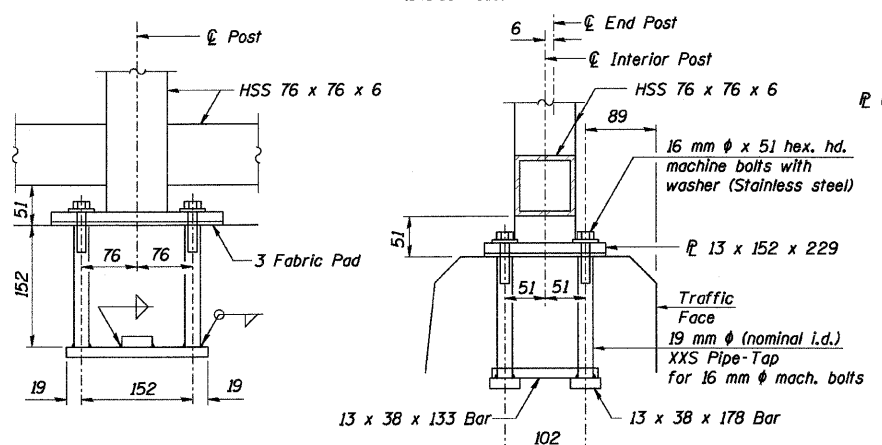

**ANCHOR BOLT DETAILS**

In lieu of the cast-in-place anchor device shown, the Contractor has the option of drilling and setting 16 mm φ anchor rods according to Article 509.06 of the Standard Specifications. Embedment shall be according to the manufacturer's specifications.

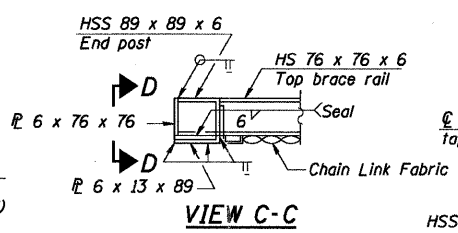

**VIEW C-C**

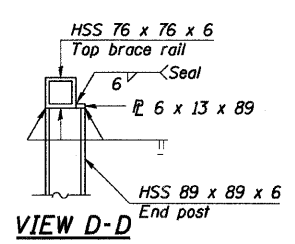

**VIEW D-D**

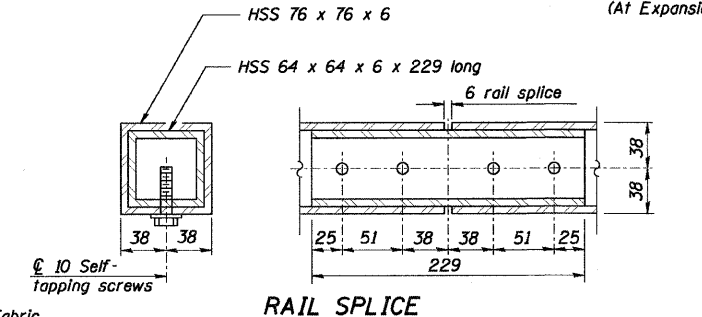

**RAIL SPLICE**

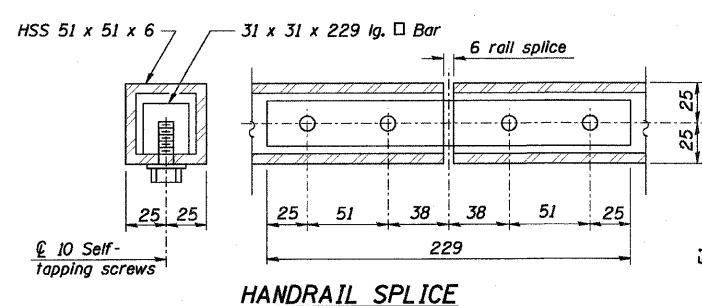

**HANDRAIL SPLICE**

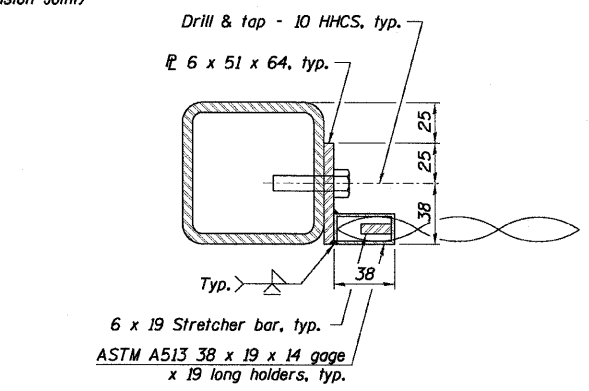

**SECTION E-E**

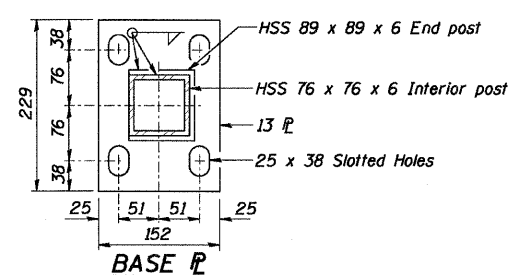

**BASE P**

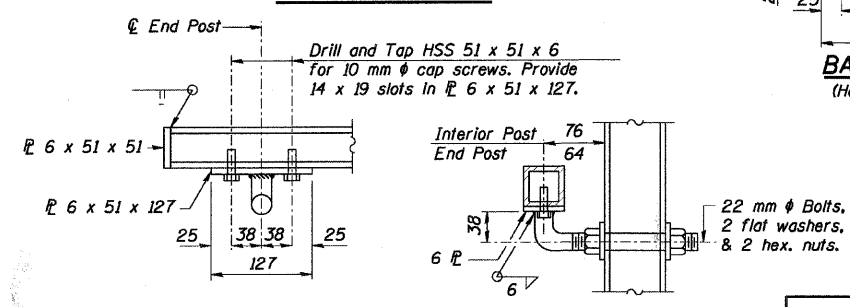

**HANDRAIL DETAIL**

**BILL OF MATERIAL**

Item	Unit	Quantity
Bridge Fence Railing	Meter	145.5

**BRIDGE FENCE RAILING  
PARAPET MOUNTED**

\*Variable - See Plans  
(10'-0" Maximum Post Spacing)

REVISIONS	
NAME	DATE

ILLINOIS DEPARTMENT OF TRANSPORTATION  
115 TH. STREET OVER FAI 57  
FAU RTE. 1584 SEC. 068-1919.2-CF  
COOK COUNTY  
STATION 2+382.915  
STRUCTURE NO. 016-2037

**BRIDGE FENCE RAILING**

DRAWN BY DR  
CHECKED BY ERB/DGS  
DATE: JANUARY 16, 2009

**COLLINS ENGINEERS**  
123 North Wacker Drive  
Suite 300  
Chicago, IL 60606  
(312) 704-9300  
www.collinseng.com  
ILLINOIS PROFESSIONAL DESIGN FIRM LICENSE NO. 184-080993

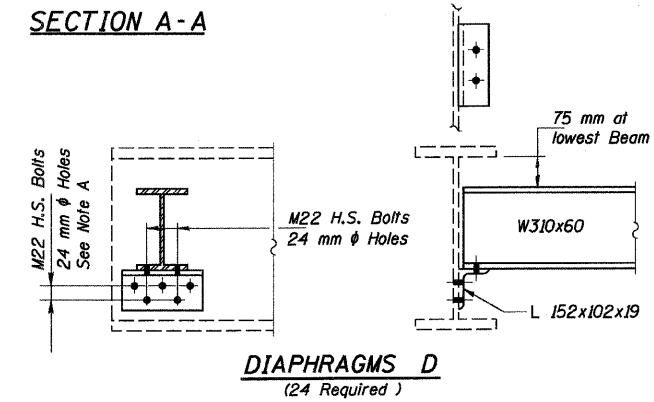
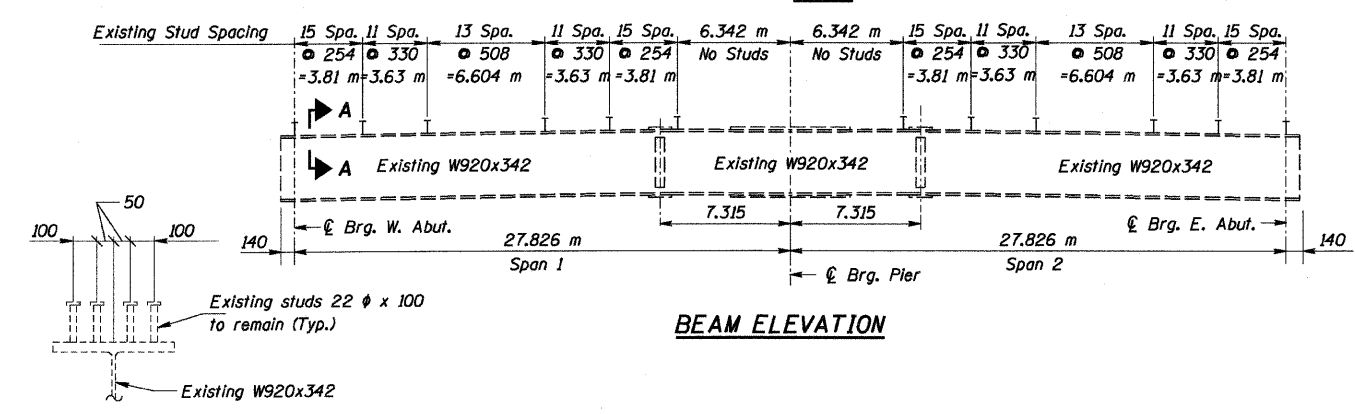
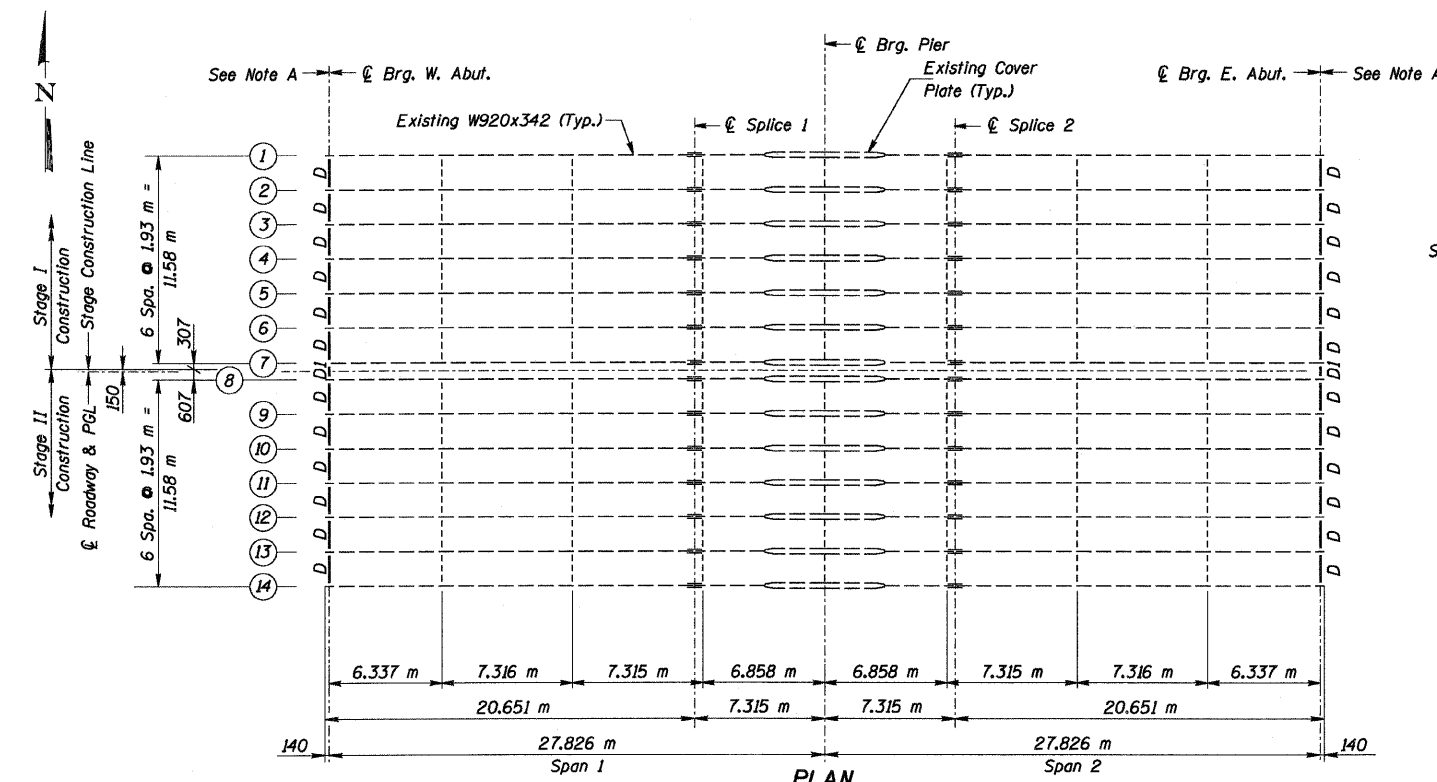

**Note A:**  
Remove existing 22 mm phi rivets or bolts and replace with M22 H.S. Bolts with 24 mm phi holes. Place bolts finger tight until after placement of Stage II Concrete, then tighten according to Specifications. Cost of existing diaphragm removal, including connection hardware to existing beams, is included with Structural Steel Removal. Cost of fabricating new connection angles to match existing bolt holes in beam webs is included with Furnishing and Erecting Structural Steel.

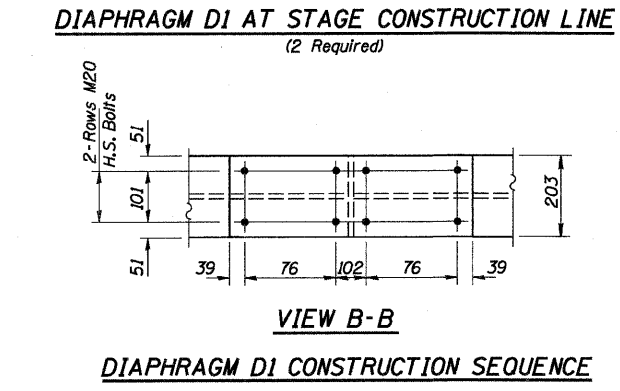
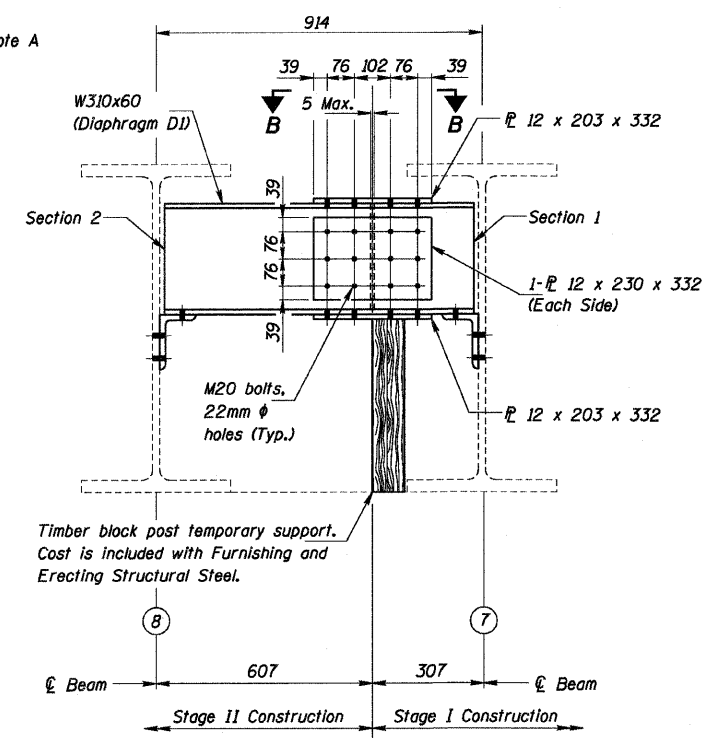

INTERIOR BEAM MOMENT TABLE		
0.4 Sp. 1 & 2		
Pier 1		
$I_s$ ( $10^6 \text{ mm}^4$ )	6250	9948
$I_c (n)$ ( $10^6 \text{ mm}^4$ )	17440	—
$I_c (3n)$ ( $10^6 \text{ mm}^4$ )	11950	—
$S_s$ ( $10^3 \text{ mm}^3$ )	13710	20800
$S_c (n)$ ( $10^3 \text{ mm}^3$ )	21290	—
$S_c (3n)$ ( $10^3 \text{ mm}^3$ )	18590	—
$Z$ ( $10^3 \text{ mm}^3$ )	—	23170
$Q$ (kN/m)	14.4	18.8
$M_D$ (kN-m)	730	1907
$s_D$ (kN/m)	4.34	—
$M_{sD}$ (kN-m)	251	—
$M_L$ (kN-m)	903	625
$M$ (Imp) (kN-m)	209	144
$\Psi_2 [M_L + M(\text{Imp})]$ (kN-m)	1854	1282
$M_a$ (kN-m)	3684	4145
$M_u$ (kN-m)	5988	5767
$f_{sD} \text{ non-comp}$ (MPa)	53.2	91.7
$f_{sD} \text{ (comp)}$ (MPa)	13.5	—
$f_{s \frac{2}{3} L + \text{Imp}}$ (MPa)	87.1	61.6
$f_s \text{ (Overload)}$ (MPa)	154	153
$f_s \text{ (Total)}$ (MPa)	—	—
$VR$ (kN)	240	—

\*\* Compact, braced Section

INTERIOR BEAM REACTION TABLE		
	Abut.	Pier
$R_D$ (kN)	193	659
$R_L$ (kN)	181	247
$\text{Imp.}$ (kN)	42	57
$R \text{ (Total)}$ (kN)	416	963

$I_s$  and  $S_s$  are the moment of inertia and section modulus of the steel section used in computing  $f_s$  (Total & Overload).  
 $I_{c(n)}$  and  $S_{c(n)}$  are the moment of inertia and section modulus of the composite section used in computing stresses due to Live Load.  
 $I_{c(3n)}$  and  $S_{c(3n)}$  are the moment of inertia and section modulus of the composite section used in computing stresses due to superimposed dead loads. (see AASHTO 10.38)  
 $VR$  is the maximum Live Load + Impact shear range in span.  
 $Z$  is the plastic section modulus used to determine the fully plastic moments in the non-composite areas.  
 $M_a$  (Applied Moment) =  $1.3[M_D + M_{sD} + \Psi_2(M_L + M_{\text{Imp}})]$ .  
The Plastic Moment capacity ( $M_u$ ) is computed according to AASHTO 10.48.1 and 10.50.1.1.  
 $f_s$  (Overload) is the sum of the stresses due to  $M_D + M_{sD} + \Psi_2(M_L + M_{\text{Imp}})$ .  
 $f_s$  (Total) (Non-compact section) is the sum of the stresses due to  $1.3[M_D + M_{sD} + \Psi_2(M_L + M_{\text{Imp}})]$ .

**Notes:**  
Two hardened washers shall be required over all oversize holes for diaphragms.  
All dimensions are in millimeters (mm) except as noted.

LOCATION	EXISTING TOP OF BEAM ELEVATIONS													
	BEAM													
	1	2	3	4	5	6	7	8	9	10	11	12	13	14
€ Brg. W. Abut.	188.201	188.213	188.230	188.252	188.266	188.298	188.305	188.306	188.277	188.262	188.244	188.231	188.200	188.195
€ Splice 1	188.450	188.439	188.459	188.477	188.514	188.526	188.671	188.662	188.543	188.517	188.498	188.474	188.430	188.432
€ Pier 1	188.441	188.439	188.459	188.477	188.495	188.516	188.527	188.527	188.523	188.497	188.468	188.455	188.430	188.432
€ Splice 2	188.431	188.439	188.459	188.477	188.476	188.507	188.383	188.393	188.504	188.478	188.440	188.436	188.430	188.432
€ Brg. E. Abut.	187.953	187.950	187.971	187.984	188.020	188.043	188.077	188.066	188.035	188.021	188.003	187.984	187.962	187.951

REVISIONS	
NAME	DATE

ILLINOIS DEPARTMENT OF TRANSPORTATION  
115 TH. STREET OVER FAI 57  
FAU RTE. 1584 SEC. 068-1919.2-CF  
COOK COUNTY  
STATION 2+382.915  
STRUCTURE NO. 016-2037  
**FRAMING PLAN**  
DRAWN BY KAC  
CHECKED BY JMH/DGS  
DATE: JANUARY 16, 2009

**COLLINS ENGINEERS**  
123 North Wacker Drive  
Suite 300  
Chicago, IL 60606  
(312) 704-9300  
www.collinsengr.com  
ILLINOIS PROFESSIONAL DESIGN FIRM LICENSE NO. 184-00993

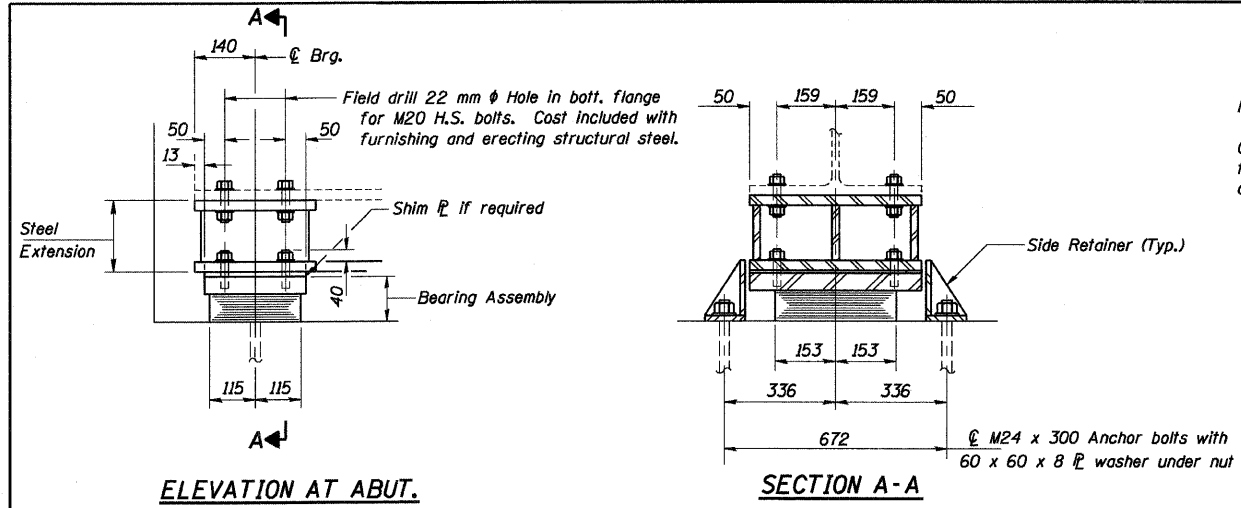

**Notes:**  
 Existing top bearing plate welded to existing beam at abutments must be removed. Contractor must exercise caution as not to damage bottom flange. Existing top plate to be removed using the air-arc method and grind smooth all weld material remaining on the bottom flange.  
 See Sheet S20 of S23 for Anchor Bolt installation.  
 All dimensions are in millimeters (mm) except as noted.

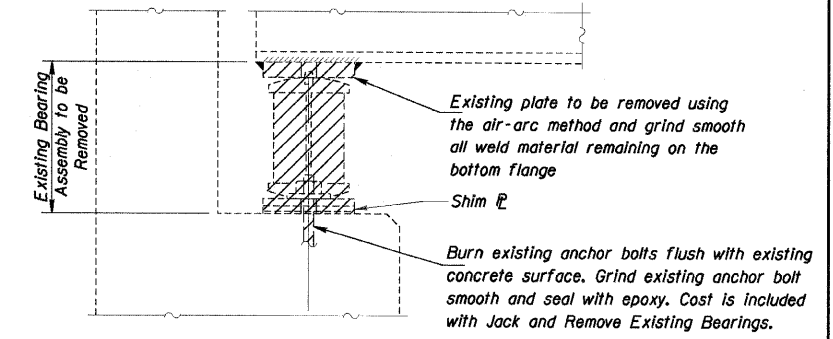

**EXISTING ABUTMENT BEARING REMOVAL DETAIL**  
 Contractor must exercise caution as not to damage bottom flange.

**ELEVATION AT ABUT.**  
**SECTION A-A**  
**TYPE I ELASTOMERIC EXP. BRG.**

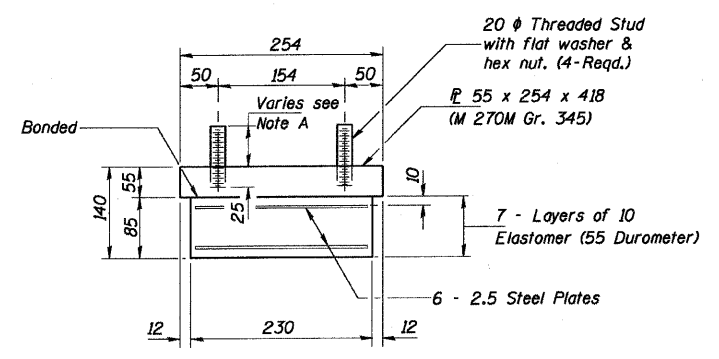

**Notes:**  
 Shim plates shall be the same length and width of the new elastomeric bearing top plate.  
 Shim plates shall not be placed under Bearing Assembly.

**Note A:**  
 Height of stud = 72 minimum plus shim plate thickness

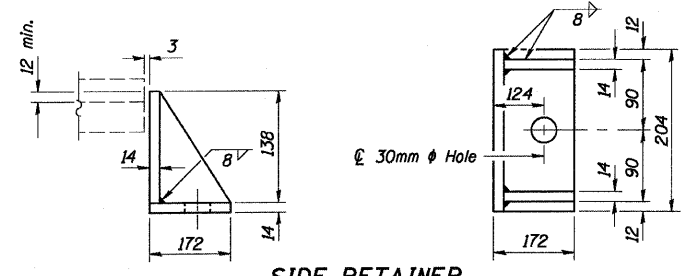

**SIDE RETAINER**  
 Equivalent rolled angle with stiffeners will be allowed in lieu of welded plates. Weight included with Structural Steel.

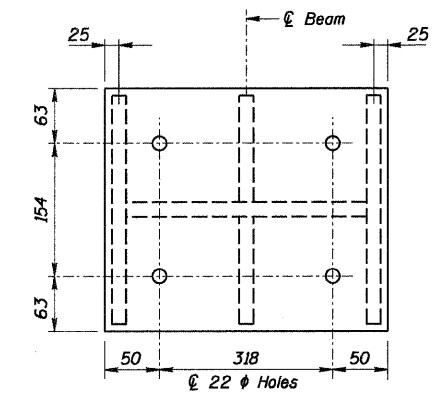

**PLAN STEEL EXTENSION**

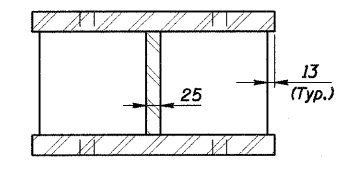

**SECTION B-B**

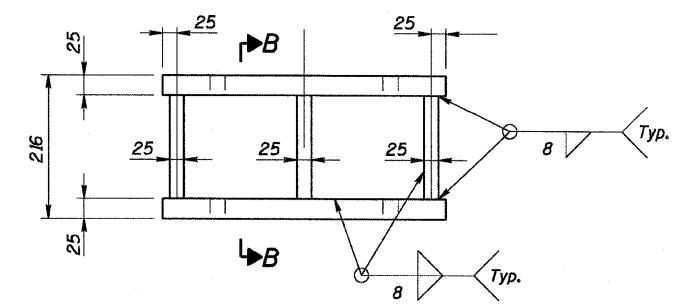

**ELEVATION STEEL EXTENSION**

**Note:**  
 Prior to ordering any material, the Contractor shall verify in the field all bearing height and shim thickness dimensions.

**BILL OF MATERIAL**

ITEM	UNIT	TOTAL
Elastomeric Bearing Assembly Type I	Each	28
Jack and Remove Existing Bearings	Each	28

LOCATION	BEAM 1	BEAM 2	BEAM 3	BEAM 4	BEAM 5	BEAM 6	BEAM 7	BEAM 8	BEAM 9	BEAM 10	BEAM 11	BEAM 12	BEAM 13	BEAM 14
East Abutment	11	8	10	4	21	24	39	28	16	22	23	23	20	9
West Abutment	10	22	20	23	18	30	18	19	9	14	15	21	9	4

The shim plate thicknesses have been determined from elevations on As-Built drawings and are subject to nominal construction variations. It is the Contractor's responsibility to verify the shim plate thicknesses required for each bearing location and make the necessary approved adjustments prior to ordering materials. Any variations shall not be cause for additional compensation for a change in scope of work, however, the Contractor will be paid for the quantity of shim plates furnished at the unit bid price for Furnishing and Erecting Structural Steel.

**COLLINS ENGINEERS**  
 123 North Wacker Drive  
 Suite 300  
 Chicago, IL 60606  
 (312) 704-9300  
 www.collinsengr.com  
 ILLINOIS PROFESSIONAL DESIGN FIRM LICENSE NO. 184-080993

REVISIONS		ILLINOIS DEPARTMENT OF TRANSPORTATION 115 TH. STREET OVER FAI 57 FAU RTE. 1584 SEC. 068-1919.2-CF COOK COUNTY STATION 2+382.915 STRUCTURE NO. 016-2037 <b>BEARING DETAILS</b>
NAME	DATE	
		DRAWN BY KAC CHECKED BY MDK/DCS DATE: JANUARY 16, 2009

ROUTE NO.	SECTION	COUNTY	TOTAL SHEETS	SHEET NO.	SHEET NO. S14 S23 SHEETS
FAU 1584	*	COOK	119	87	
FED. ROAD DIST. NO. 7	ILL. LINE	FED. AID PROJECT	CONTRACT 60371		

• 068-1919.2-CF

Scarification of existing sidewalk (Typ.)  
See Sheet S16 of S23 for topping details

Existing sidewalk removal (Typ.)  
See Sheet S16 of S23 for replacement details

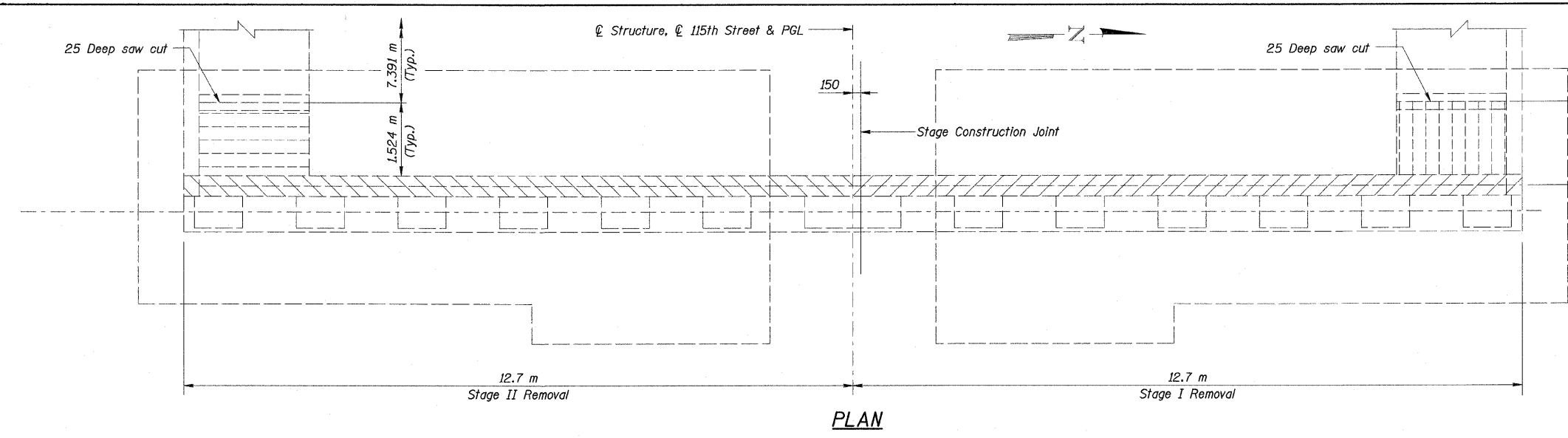

**PLAN**

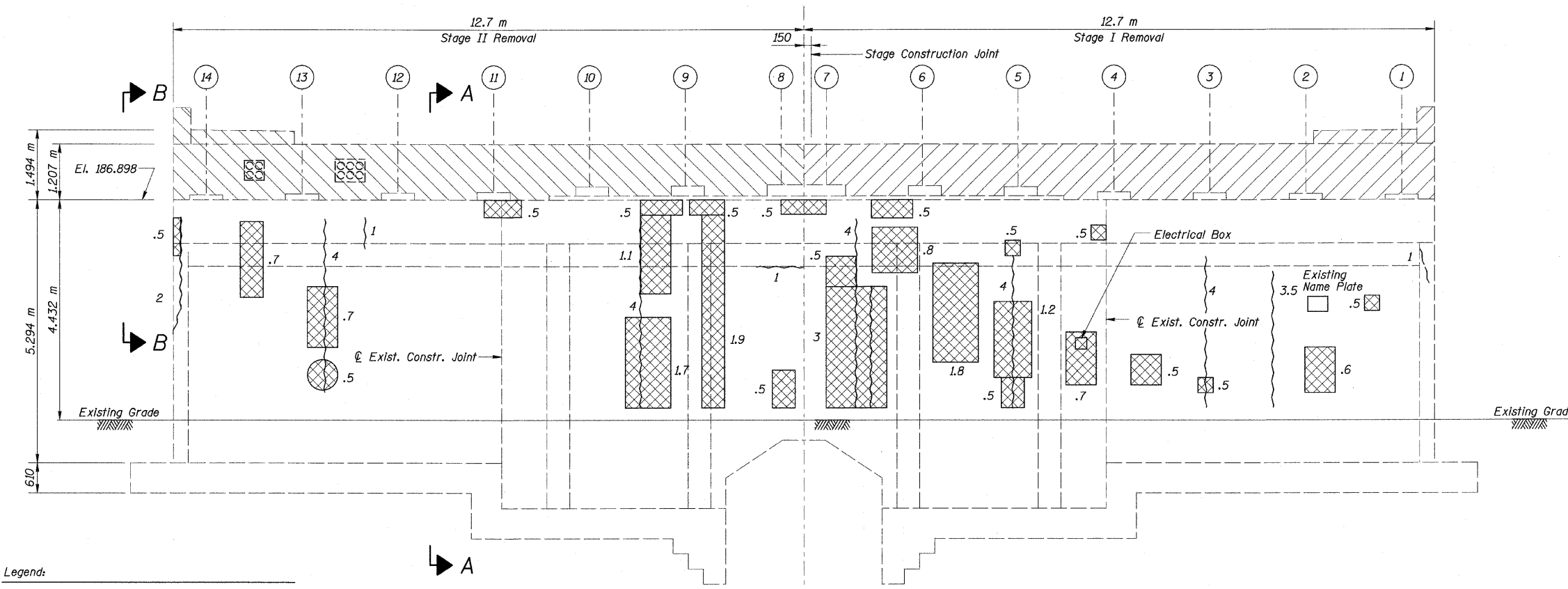

**ELEVATION**

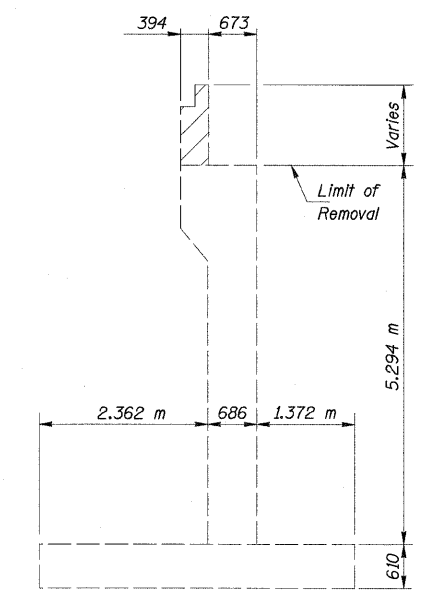

**SECTION A-A**

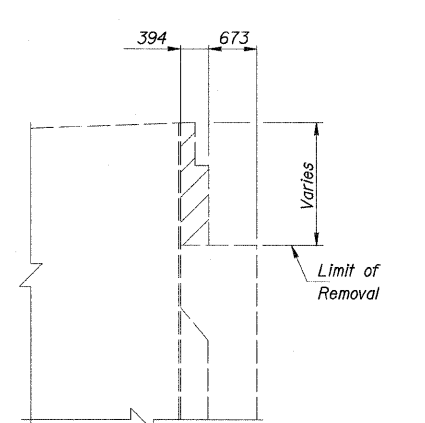

**SECTION B-B**

**Legend:**

- Stage I Removal  
Denotes concrete removal, existing vertical bars to remain
- Stage II Removal  
Denotes concrete removal, existing vertical bars to remain
- Stage I Removal  
Denotes concrete removal, existing 203 sidewalk to be removed, existing longitudinal bars to remain
- Stage II Removal  
Denotes concrete removal, existing 203 sidewalk to be removed, existing longitudinal bars to remain
- Indicates Epoxy Crack Injection in meters
- Indicates Structural Repair of Concrete < 125mm in square meters

**Notes:**

Clean, straighten and incorporate existing vertical reinforcement for backwall and existing longitudinal reinforcement for sidewalks in new construction. Cost included with Concrete Removal.

During concrete removal the Contractor shall exercise care not to nick, gouge or otherwise damage the existing reinforcement that will be incorporated into the new construction.

All dimensions are in millimeters (mm) except as noted.

Burn existing anchors bolts flush with existing concrete surface.

Concrete repair quantities shown in the Bill of Materials have been increased to account for additional concrete deterioration since original inspection has taken place.

**BILL OF MATERIAL**

ITEM	UNIT	TOTAL
Concrete Removal	m <sup>3</sup>	15.2
Structural Repair of Concrete < 125mm	m <sup>2</sup>	25.0
Epoxy Crack Sealing	m	33.0

REVISIONS	
NAME	DATE

ILLINOIS DEPARTMENT OF TRANSPORTATION  
115 TH. STREET OVER FAI 57  
FAU RTE. 1584 SEC. 068-1919.2-CF  
COOK COUNTY  
STATION 2+382.915  
STRUCTURE NO. 016-2037

**WEST ABUTMENT REMOVAL**

DRAWN BY KAC  
CHECKED BY MDK/DGS  
DATE: JANUARY 16, 2009

**COLLINS ENGINEERS**  
123 North Wacker Drive  
Suite 300  
Chicago, IL 60606  
(312) 704-9300  
www.collinsengr.com  
ILLINOIS PROFESSIONAL DESIGN FIRM LICENSE NO. 184-000993

ROUTE NO.	SECTION	COUNTY	TOTAL SHEETS	SHEET NO.
FAU 1584		COOK	119	88
FED. ROAD DIST. NO. 7		ILLINOIS	FED. AID PROJECT-	
068-1919.2-CF		CONTRACT 60371		

SHEET NO. S15  
S23 SHEETS

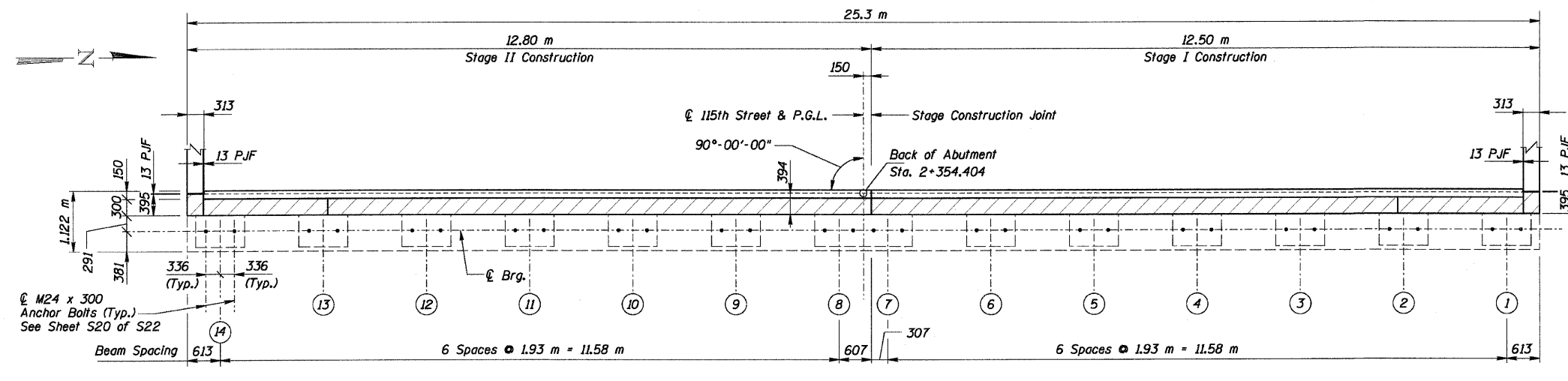

**Notes:**  
 Hatched area to be poured after superstructure falsework has been removed. Quantity of Concrete included with Concrete Superstructure, on Sheet S16 of S23.  
 All dimensions are in millimeters (mm) except as noted. See Sheet S16 of S23 for Sections A-A and Bill of Material. Bars indicated thus 5x2-#15 etc. indicates 5 lines of bars with 2 lengths per line.  
 \*\* Epoxy grout bars 230 (Min.) drilled holes according to Article 584 of the Standard Specifications. Space drilled holes in existing cap to miss existing reinforcement.

**PLAN**

**Minimum Bar Laps:**  
 #15 Bars = 640  
 #20 Bars = 790

**Legends:**  
 F.F. = Front Face  
 B.F. = Back Face  
 E.F. = Each Face

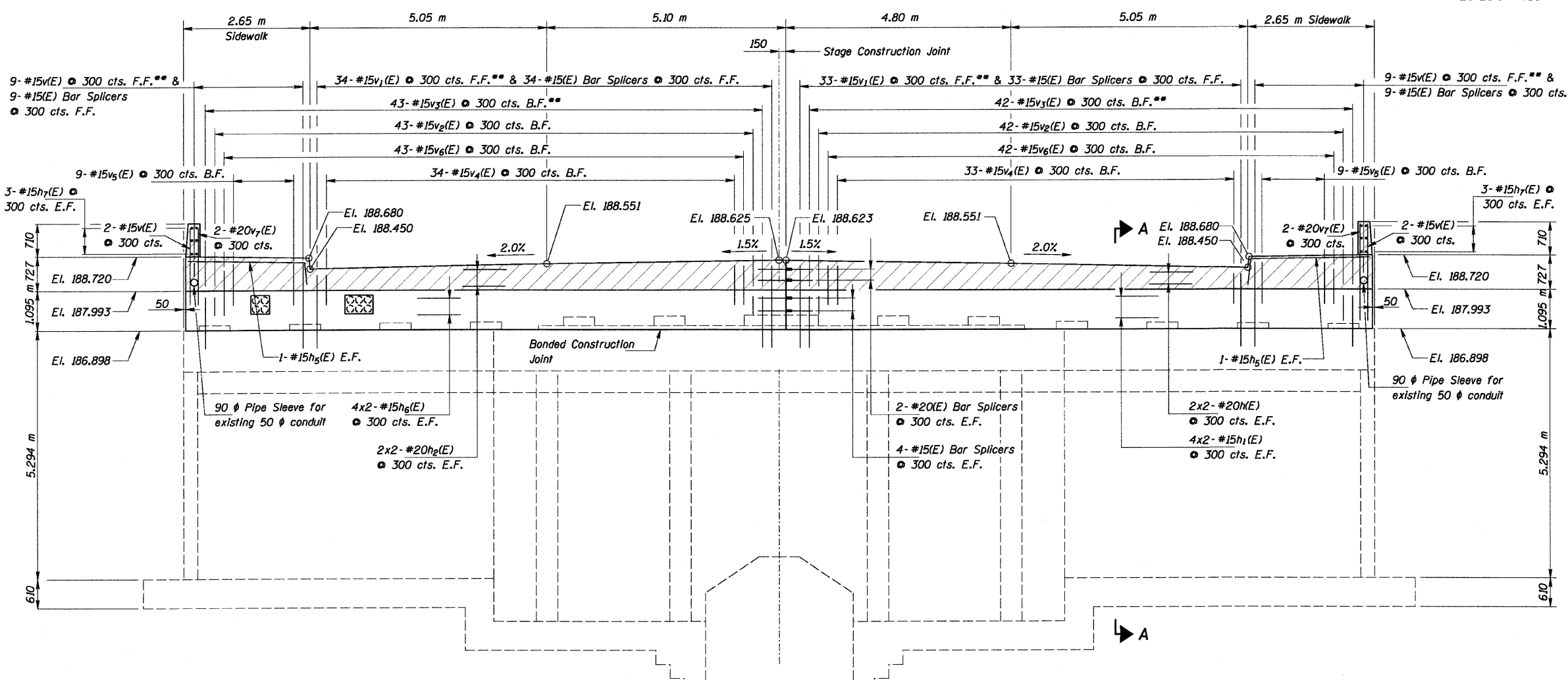

**ELEVATION**

REVISIONS	
NAME	DATE

ILLINOIS DEPARTMENT OF TRANSPORTATION  
 115 TH. STREET OVER FAI 57  
 FAU RTE. 1584 SEC. 068-1919.2-CF  
 COOK COUNTY  
 STATION 2+382.915  
 STRUCTURE NO. 016-2037

**WEST ABUTMENT DETAILS-I**

DRAWN BY KAC  
 CHECKED BY MDK/DGS  
 DATE: JANUARY 16, 2009

**COLLINS ENGINEERS**  
 123 North Wacker Drive  
 Suite 300  
 Chicago, IL 60606  
 (312) 704-9300  
 www.collinseng.com  
 ILLINOIS PROFESSIONAL DESIGN FIRM LICENSE NO. 184-000995





ROUTE NO.	SECTION	COUNTY	TOTAL SHEETS	SHEET NO.	SHEET NO. S17
FAU 1584	*	COOK	119	90	S23 SHEETS
FED. ROAD DIST. NO. 7	ILLINOIS	FED. AID PROJECT-			

\* 068-1919.2-CF CONTRACT 60371

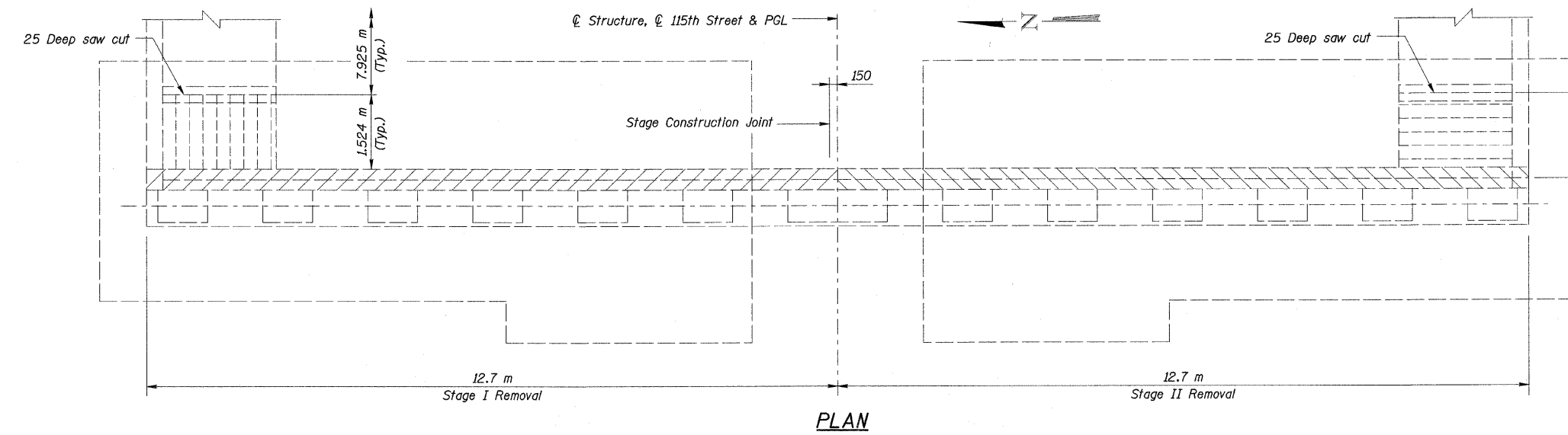

**PLAN**

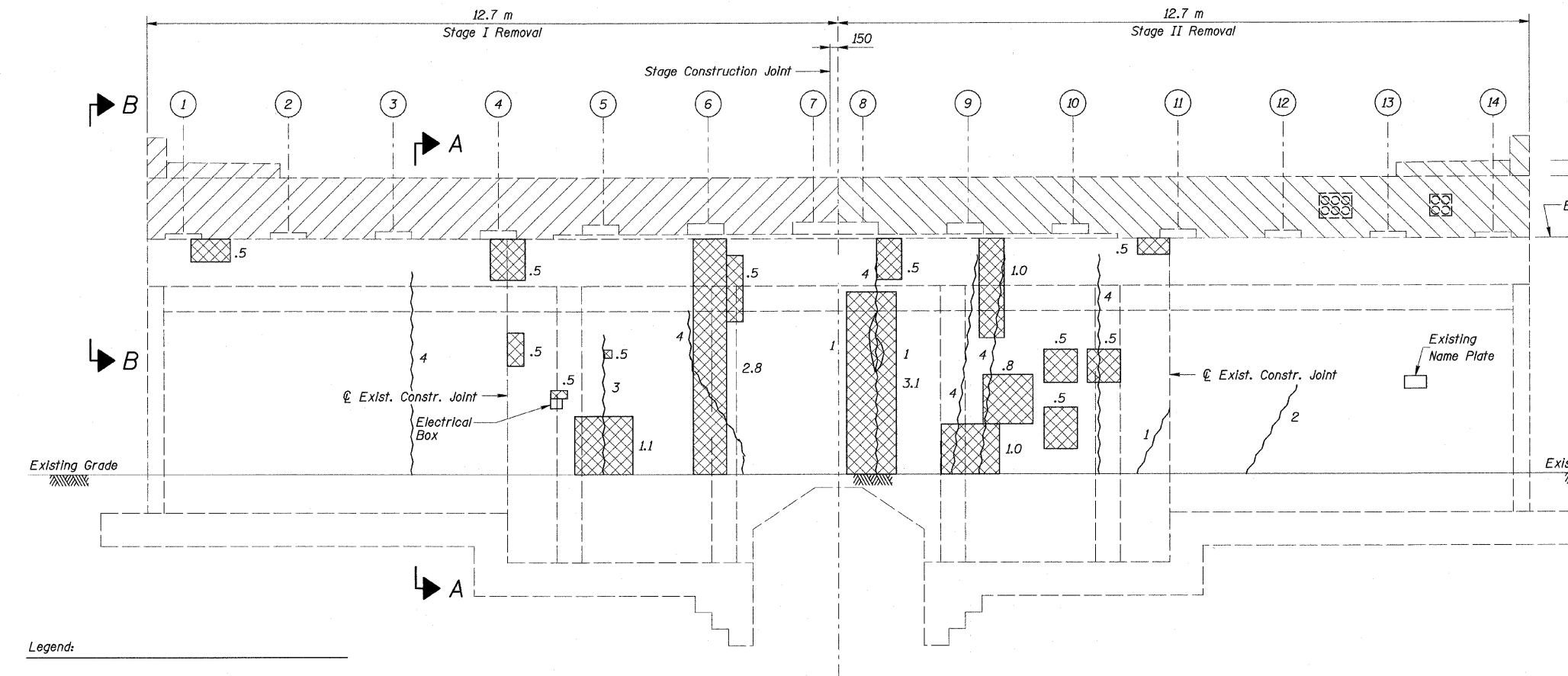

**ELEVATION**

- Legend:**
- Stage I Removal  
Denotes concrete removal, existing vertical bars to remain
  - Stage II Removal  
Denotes concrete removal, existing vertical bars to remain
  - Stage I Removal  
Denotes concrete removal, existing 203 sidewalk to be removed, existing longitudinal bars to remain
  - Stage II Removal  
Denotes concrete removal, existing 203 sidewalk to be removed, existing longitudinal bars to remain
  - Indicates Epoxy Crack Injection in meters
  - Indicates Structural Repair of Concrete ≤ 125mm in square meters

**Notes:**  
 Clean, straighten and incorporate existing vertical reinforcement for backwall and existing longitudinal reinforcement for sidewalks in new construction. Cost included with Concrete Removal.  
 During concrete removal the Contractor shall exercise care not to nick, gouge or otherwise damage the existing reinforcement that will be incorporated into the new construction.  
 All dimensions are in millimeters (mm) except as noted.  
 Burn existing anchors bolts flush with existing concrete surface.  
 Concrete repair quantities shown in the Bill of Materials have been increased to account for additional concrete deterioration since original inspection has taken place.

Scarification of existing sidewalk (Typ.)  
See Sheet S19 of S23 for topping details

Existing sidewalk removal (Typ.)  
See Sheet S19 of S23 for replacement details

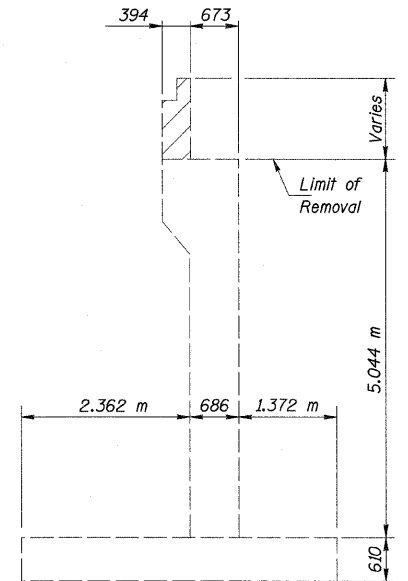

**SECTION A-A**

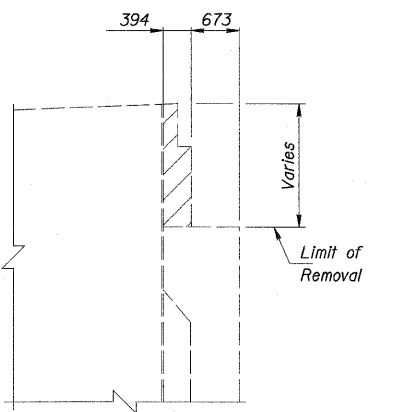

**SECTION B-B**

**BILL OF MATERIAL**

ITEM	UNIT	TOTAL
Concrete Removal	m <sup>3</sup>	15.1
Structural Repair of Concrete ≤ 125mm	m <sup>2</sup>	18.0
Epoxy Crack Sealing	m	37.0

REVISIONS	
NAME	DATE

**COLLINS ENGINEERS**  
 123 North Wacker Drive  
 Suite 300  
 Chicago, IL 60606  
 (312) 704-9300  
 www.collinseng.com  
 ILLINOIS PROFESSIONAL DESIGN FIRM LICENSE NO. 184-000993

ILLINOIS DEPARTMENT OF TRANSPORTATION  
 115 TH. STREET OVER FAI 57  
 FAU RTE. 1584 SEC. 068-1919.2-CF  
 COOK COUNTY  
 STATION 2+382.915  
 STRUCTURE NO. 016-2037  
**EAST ABUTMENT REMOVAL**  
 DRAWN BY KAC  
 CHECKED BY MDK/DGS  
 DATE: JANUARY 16, 2009

ROUTE NO.	SECTION	COUNTY	TOTAL SHEETS	SHEET NO.	SHEET NO. S18
FAU 1584	*	COOK	119	91	S23 SHEETS
FED. ROAD DIST. NO. 7		ILLINOIS	FED. AID PROJECT		
068-1919.2-CF		CONTRACT 60371			

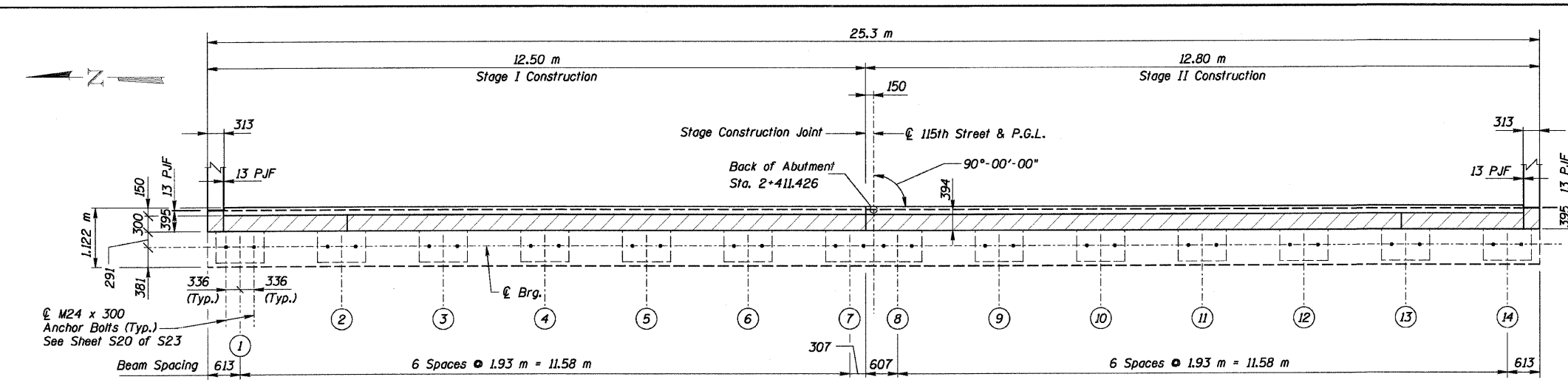

**Notes:**

Hatched area to be poured after superstructure falsework has been removed. Quantity of Concrete included with Concrete Superstructure, on sheet S19 of S23.

All dimensions are in millimeters (mm) except as noted. See Sheet S19 of S23 for Sections A-A and Bill of Material. Bars indicated thus 5x2-#15 etc. indicates 5 lines of bars with 2 lengths per line.

\*\* Epoxy grout bars 230 (Min.) drilled holes according to Article 584 of the Standard Specifications. Space drilled holes in existing cap to miss existing reinforcement.

**Minimum Bar Laps:**

#15 Bars = 640  
#20 Bars = 790

**Legend:**

F.F. = Front Face  
B.F. = Back Face  
E.F. = Each Face

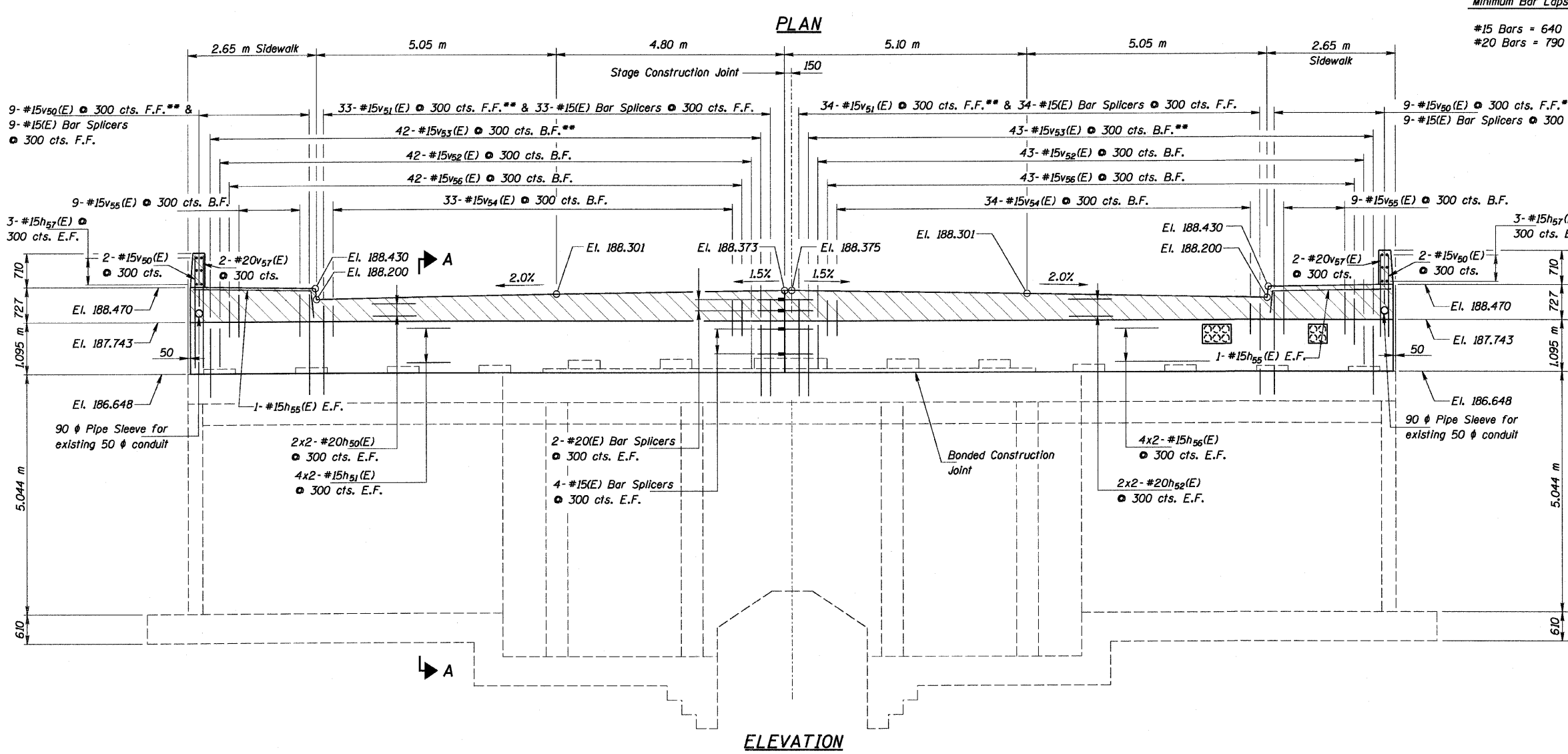

**COLLINS ENGINEERS**  
123 North Wacker Drive  
Suite 300  
Chicago, IL 60606  
(312) 704-9300  
www.collinsengr.com  
ILLINOIS PROFESSIONAL DESIGN FIRM LICENSE NO. 184-000993

REVISIONS	
NAME	DATE

ILLINOIS DEPARTMENT OF TRANSPORTATION  
115 TH. STREET OVER FAI 57  
FAU RTE. 1584 SEC. 068-1919.2-CF  
COOK COUNTY  
STATION 2+382.915  
STRUCTURE NO. 016-2037

**EAST ABUTMENT DETAILS-I**

DRAWN BY KAC  
CHECKED BY MDK/DGS  
DATE: JANUARY 16, 2009

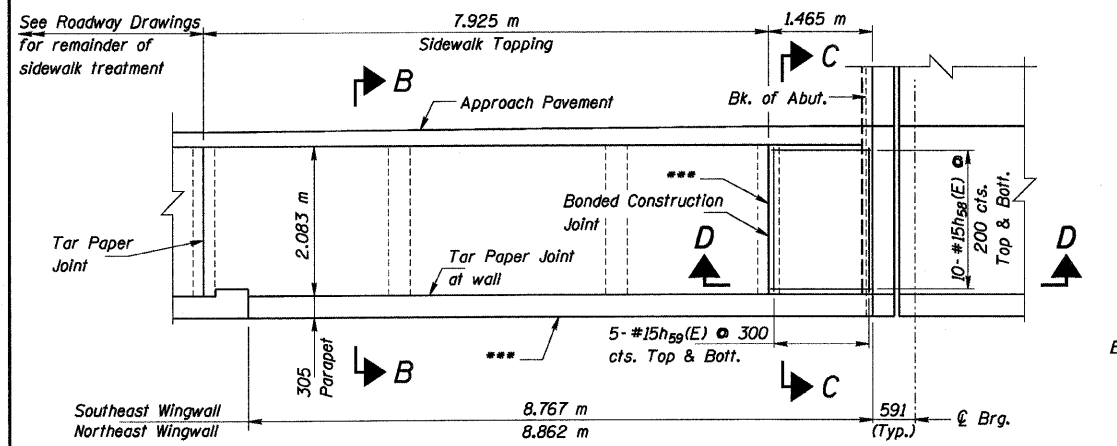

**WINGWALL & SIDEWALK PLAN**  
(Northeast Wingwall Shown, Southeast Wingwall Similar)

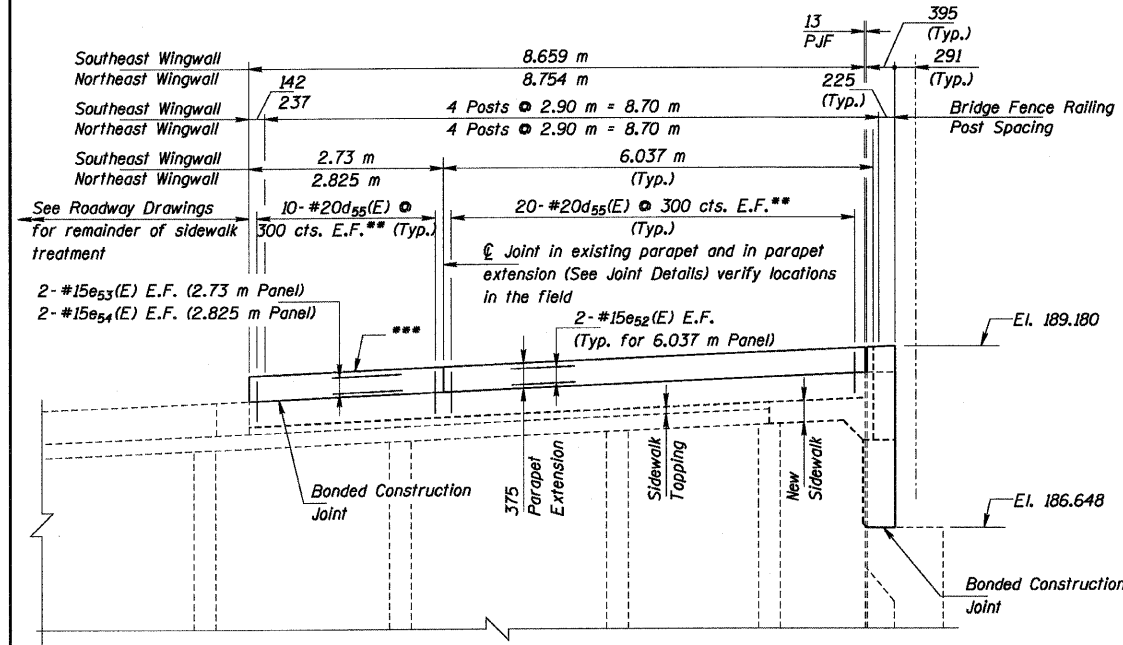

**ELEVATION**

Note:  
Existing railing attached to wingwalls is to be removed and delivered to IDOT District 1 Bridge Office in locations of the parapet extension. Cost of this work is included in Removal of Existing Concrete Deck bid item. See General Notes for more information.

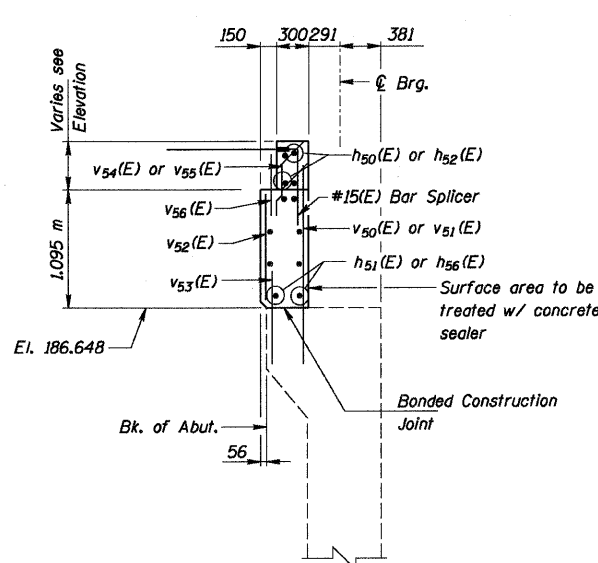

**SECTION A-A**

Hatched area to be poured after superstructure forms have been removed. Quantity of Concrete included with Concrete Superstructure.

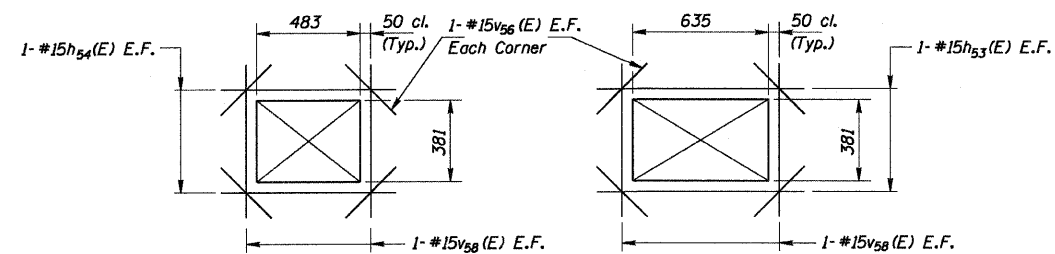
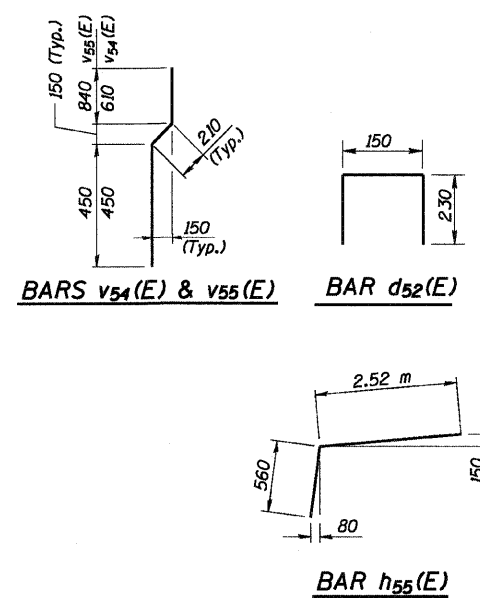

**4-CONDUIT BLOCKOUT**  
**6-CONDUIT BLOCKOUT**  
**ADDITIONAL REINFORCEMENT FOR BLOCKOUTS**

Note:  
Cut or adjust backwall reinforcement as required to miss blockout. Contractor to completely fill space around conduits for full depth of abutment backwall. Contractor may also elect to use pipe sleeves instead of blockout, subject to the approval of the Engineer. Cost shall be included in the cost of Concrete Structures.

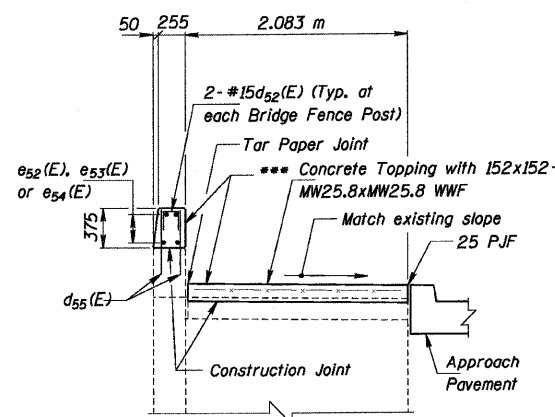

**SECTION B-B**

Note:  
Existing surface of sidewalk shall be scarified and roughened to 6mm Irregularities. Cost is included in the cost of Concrete Superstructure.

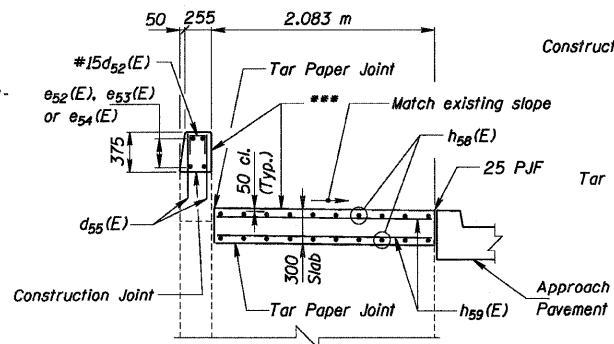

**SECTION C-C**

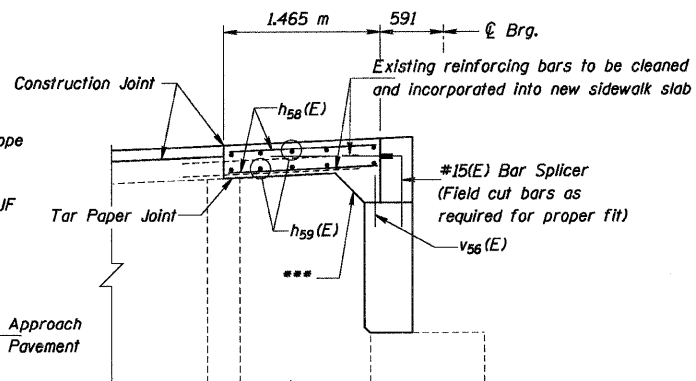

**SECTION D-D**

Legend:  
F.F. = Front Face  
B.F. = Back Face  
E.F. = Each Face

Notes:  
All dimensions are in millimeters (mm) except as noted. See Sheet S10 of S23 for Parapet Joint Details.  
\*\* Epoxy grout bars 230 (Min.) drilled holes according to Article 584 of the Standard Specifications. Space drilled holes in existing cap to miss existing reinforcement.  
\*\*\* Quantity of concrete included with Concrete Superstructure.

ROUTE NO.	SECTION	COUNTY	TOTAL SHEETS	SHEET NO.	SHEET NO. S19
FAU 1584		COOK	119	92	S23 SHEETS
FED. ROAD DIST. NO. 7	ILLINOIS	FED. AID PROJECT	CONTRACT 60371		
068-1919.2-CF					

**BILL OF MATERIAL**

BAR	NO.	SIZE	LENGTH (m)	SHAPE
d52(E)	16	#15	0.61	□
d55(E)	120	#20	0.63	—
e52(E)	8	#15	5.94	—
e53(E)	4	#15	2.63	—
e54(E)	4	#15	2.73	—
h50(E)	8	#20	6.60	—
h51(E)	16	#15	6.52	—
h52(E)	8	#20	6.75	—
h53(E)	4	#15	1.34	—
h54(E)	4	#15	1.18	—
h55(E)	4	#15	3.08	□
h56(E)	16	#15	6.67	—
h57(E)	12	#15	0.35	—
h58(E)	40	#15	1.37	—
h59(E)	20	#15	1.98	—
v50(E)	22	#15	2.37	—
v51(E)	67	#15	2.28	—
v52(E)	85	#15	0.99	—
v53(E)	85	#15	0.53	—
v54(E)	67	#15	1.27	□
v55(E)	18	#15	1.50	□
v56(E)	101	#15	0.60	—
v57(E)	4	#20	2.37	—
v58(E)	8	#15	0.98	—
Concrete Structures		m <sup>3</sup>	12.4	
Reinforcement Bars				
Epoxy Coated		kg	2,050	
Structure Excavation		m <sup>3</sup>	52	
Porous Granular Embankment (Special)		m <sup>3</sup>	43	
Concrete Superstructure		m <sup>3</sup>	12.2	
Bar Splicers		Each	104	
Concrete Sealer		m <sup>2</sup>	18.5	

REVISIONS	
NAME	DATE

ILLINOIS DEPARTMENT OF TRANSPORTATION  
115 TH. STREET OVER FAI 57  
FAU RTE. 1584 SEC. 068-1919.2-CF  
COOK COUNTY  
STATION 2+382.915  
STRUCTURE NO. 016-2037

**EAST ABUTMENT DETAILS-II**

DRAWN BY KAC  
CHECKED BY MDK/DGS  
DATE: JANUARY 16, 2009

**COLLINS ENGINEERS**  
123 North Wacker Drive  
Suite 300  
Chicago, IL 60606  
(312) 794-9300  
www.collinsengr.com  
ILLINOIS PROFESSIONAL DESIGN FIRM LICENSE NO. 184-008993

The Illinois Coil-Lock Anchor Bolt is a proprietary item which is the property of the Illinois Department of Transportation. Use, reproduction or disclosure without express written permission is prohibited and protected under Federal copyright laws. The production and the fabrication of this bolt for use on highway projects in the State of Illinois shall be permitted and there shall be no incurred charges or fees to the manufacturer or the fabricator for producing or fabricating this bolt.

D	E	H	K	"d"
25	29	21	44	6

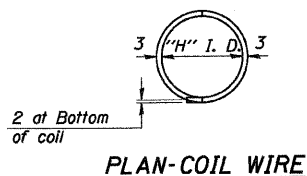
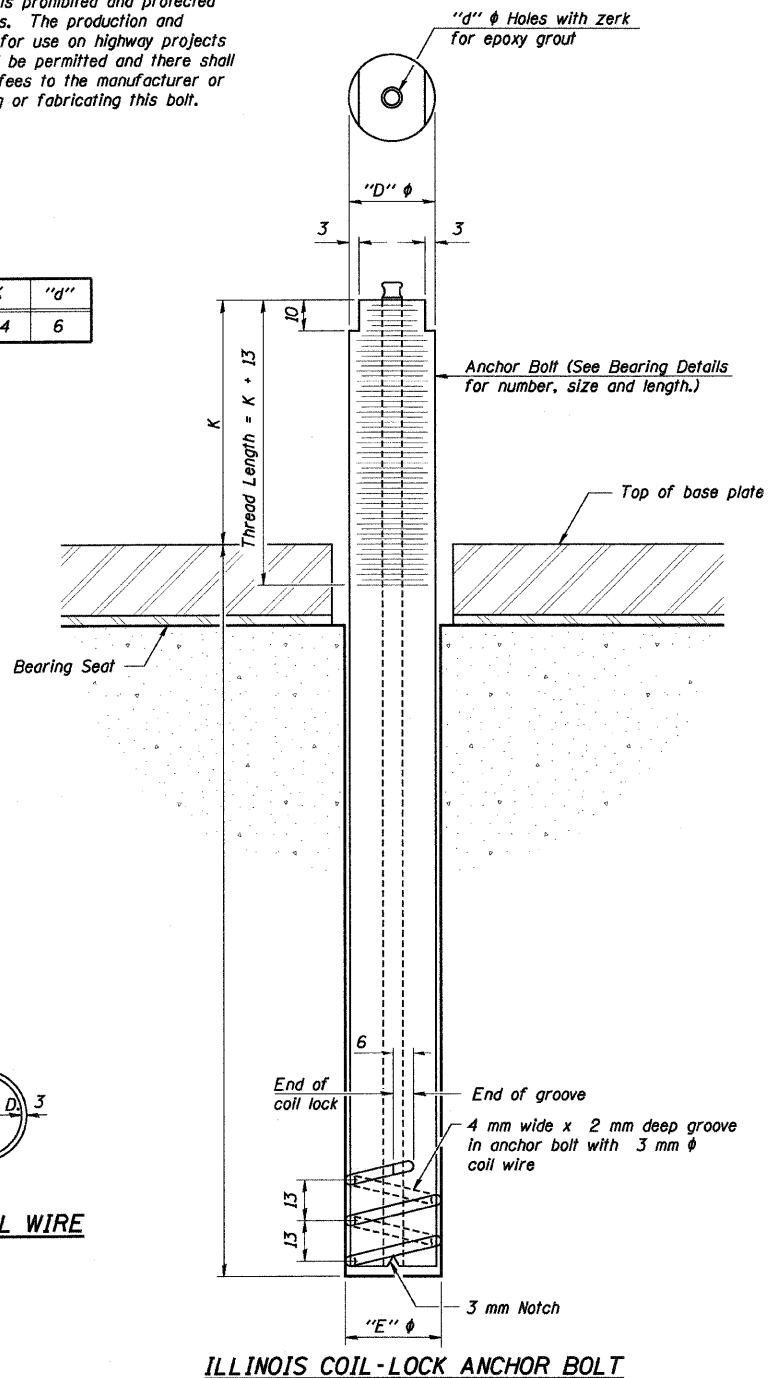

**ANCHOR BOLT DETAILS  
FOR BEARINGS**

**MATERIALS FOR ILLINOIS COIL-LOCK  
ANCHOR BOLT**

The anchor bolt shall be fabricated from cold drawn or hot finished seamless carbon steel mechanical tubing conforming to ASTM A 519, Grade 1026, CW and supplied with hexagonal nuts and cut washers.  
The coil wire shall be made of any suitable soft steel wire.  
The finished anchor bolt shall be cleaned of rust and other foreign materials and wrapped or packaged to prevent contamination until they are installed.  
The epoxy grout shall be a two-component, epoxy resin bonding system conforming to ASTM C 881, Type I, Grade 1 and of a Class suitable for the temperature at installation.

**INSTALLATION PROCEDURE for the ILLINOIS  
COIL-LOCK ANCHOR BOLT**

1. With the coil wire in place, the bolt shall be inserted into the hole and turned clockwise to a snug fit in the hole. Nut and washer shall be placed on the bolt. The nut shall be tensioned until the steel base plates are held securely to the concrete bearing seat.
2. Epoxy grout shall be pumped through the zerk fitting with a pressure gun. Pumping shall continue until the epoxy overflows the hole around the bolt shank. After pumping is discontinued, excess epoxy shall be immediately wiped off.

**ALTERNATE ANCHOR BOLTS**

The Contractor may use, at his option, the capsule or the adhesive cartridge type anchor rods that have been previously tested and given a prior approval by the Department. The Contractor shall install these anchor rods in pre-drilled holes according to the manufacturer's recommendations and procedures.

- The capsule or the adhesive cartridge type anchor rods shall be a two part system composed of:
1. A threaded rod stud with nut and washer of the type specified.
  2. A sealed glass capsule or a sealed glass adhesive cartridge containing premeasured amounts of the adhesive chemical.

Location	Type
Abutments	A307

ASTM F 1554 Grade 105, ASTM A 449 and AASHTO M 314 Grade 105 anchor bolts may be substituted for the anchor bolts shown above.

ANCHOR BOLTS REQUIRED	
Size	Quantity
24 mm $\phi$ x 300 mm	56

REVISIONS	
NAME	DATE

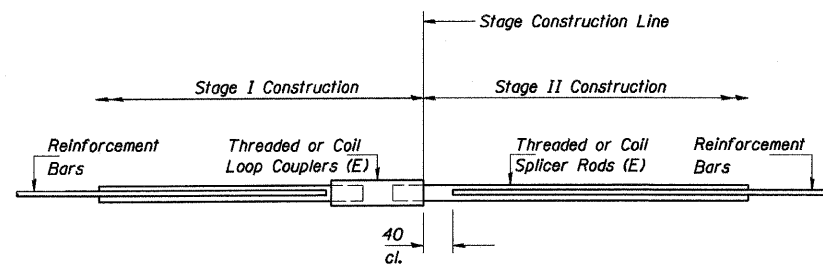

**BAR SPLICER ASSEMBLY DETAIL**

Bar Size	No. Assemblies Required	Location
#15	520	Superstructure
#15	16	E. & W. Abut.
#20	8	E. & W. Abut.

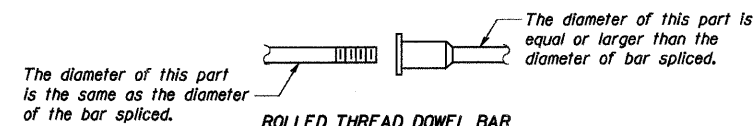

**ROLLED THREAD DOWEL BAR**



**\*\* ONE PIECE**

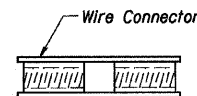

**WELDED SECTIONS**

**BAR SPLICER ASSEMBLY ALTERNATIVES**

\*\* Heavy Hex Nuts conforming to ASTM A 563M, Grade C, D or DH may be used.

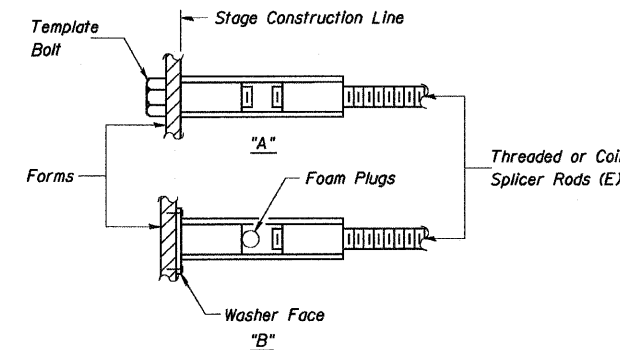

**INSTALLATION AND SETTING METHODS**

"A": Set bar splicer assembly by means of a template bolt.  
 "B": Set bar splicer assembly by nailing to wood forms or cementing to steel forms.  
 (E) : Indicates epoxy coating.

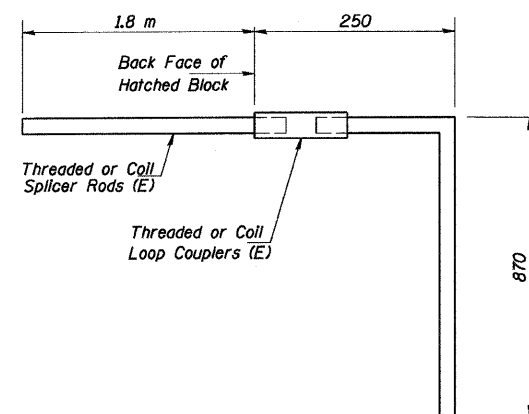

**BAR SPLICER ASSEMBLY DETAIL FOR #15 BAR AT ABUTMENTS**

Bar Size	No. Assemblies Required	Location
#15	85	West Abutment
#15	85	East Abutment

**NOTES**

Bar splicer assemblies shall be of an approved type and shall develop in tension at least 125 percent of the yield strength of the lapped reinforcement bars. Splicer rods shall be of minimum 400 MPa yield strength, threaded or coiled full length. All reinforcement bars shall be lapped and tied to the splicer rods or dowel bars. Bar splicer assemblies shall be epoxy coated according to the requirements for reinforcement bars.

Other systems of similar design may be submitted to the Engineer for approval. Approval shall be based on certified test results from an approved testing laboratory that the proposed bar splicer assembly satisfies the following requirements:

- ① Minimum Capacity =  $1.25 \times f_y \times A_1$   
(Tension in kN)
- ② Minimum Pull-out Strength =  $0.66 \times f_y \times A_1$   
(Tension in kN)

Where  $f_y$  = Yield strength of lapped reinforcement bars in MPa.  
 $A_1$  = Tensile stress area of lapped reinforcement bars ( $\text{mm}^2$ ).  
 \*\*\* = 28 day concrete

Bar Size to be Spliced	Splicer Rod or Dowel Bar Length	Strength Requirements	
		Min. Capacity kN - tension	Min. Pull-Out Strength kN - tension
#15	510 mm	70	40
#20	610 mm	110	60

Bar splicer assemblies shall be according to Section 508 of the Standard Specifications, except as noted. The furnishing and installation of bar splicer assemblies will be measured and paid for at the contract unit price each for "BAR SPLICERS."  
 All dimensions are in millimeters (mm) except as noted.

REVISIONS	
NAME	DATE

When "A" is 1067 mm or less, the temporary concrete barrier shall be anchored to the new slab according to Detail I or Detail II. No anchorage is required when "A" is greater than 1067 mm.

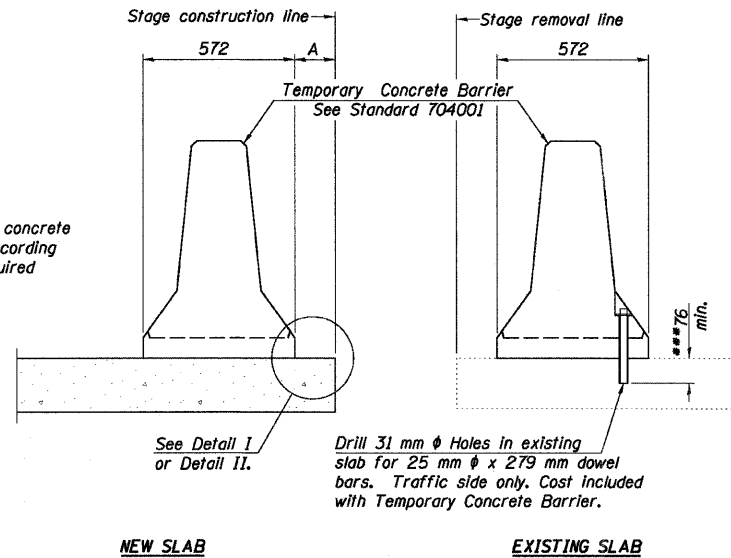

**SECTIONS THRU SLAB OR DECK BEAM**

**NOTES**

**Detail I - With Bar Splicer or Couplers:**  
Connect one (1) 25x178x254 steel  $\bar{P}$  to the top layer of couplers with 2- 16 mm  $\phi$  bolts screwed to coupler at approximate  $\bar{C}$  of each barrier panel.

**Detail II - With Extended Reinforcement Bars:**  
Connect one (1) 25x178x254 steel  $\bar{P}$  to the concrete slab or concrete wearing surface with 2- 16 mm  $\phi$  Expansion Anchors or cast in place inserts spaced between the top layer of reinforcement at approximate  $\bar{C}$  of each barrier panel.

Cost of anchorage is included with Temporary Concrete Barrier. The 25 x 178 x 254 plate shall not be removed until stage II construction forms and all reinforcement bars are in place and the concrete is ready to be placed.

\*\*\*Dimension shown is minimum required embedment into concrete. If hot-mix asphalt wearing surface is present, minimum embedment shall be in addition to wearing surface depth.

\*\*\*\*If existing deck beam is to remain in place after stage construction, embedment shall only be into wearing surface and not into existing deck beam concrete.

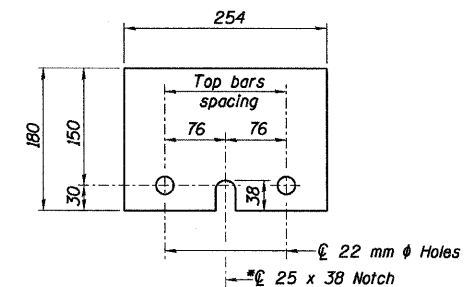
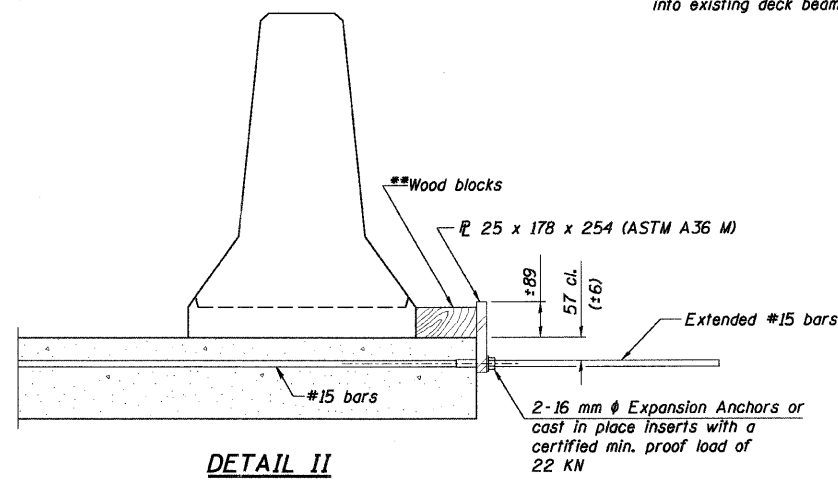
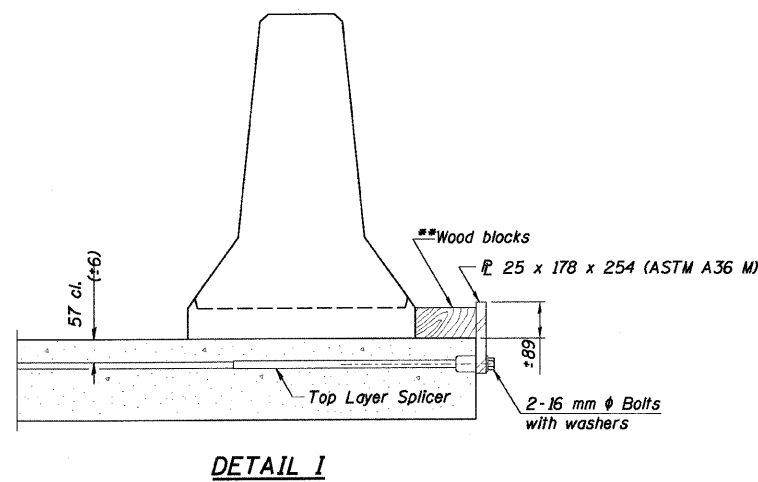

\*\*Wood blocks may be omitted when required to provide minimum stage traffic lane width. When the wood blocks are omitted, the concrete barrier shall be in direct contact with the steel retainer plate.

**TEMPORARY CONCRETE BARRIER FOR STAGE CONSTRUCTION**

REVISIONS		ILLINOIS DEPARTMENT OF TRANSPORTATION 115 TH. STREET OVER FAI 57 FAU RTE. 1584 SEC. 068-1919.2-CF COOK COUNTY STATION 2+382.915 STRUCTURE NO. 016-2037 <b>TEMPORARY CONCRETE BARRIER</b>
NAME	DATE	
		DRAWN BY DR CHECKED BY MDK/DCS                      DATE: JANUARY 16, 2009

**COLLINS ENGINEERS**  
123 North Wacker Drive  
Suite 300  
Chicago, IL 60606  
(312) 704-9300  
www.collinsengr.com  
ILLINOIS PROFESSIONAL DESIGN FIRM LICENSE NO. 184-000993

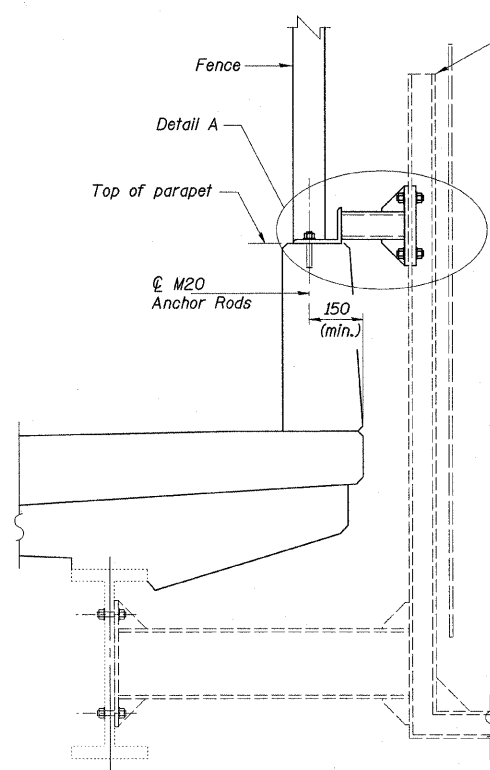

**SECTION A-A**  
Details for New Upper Bracket for existing sign structure

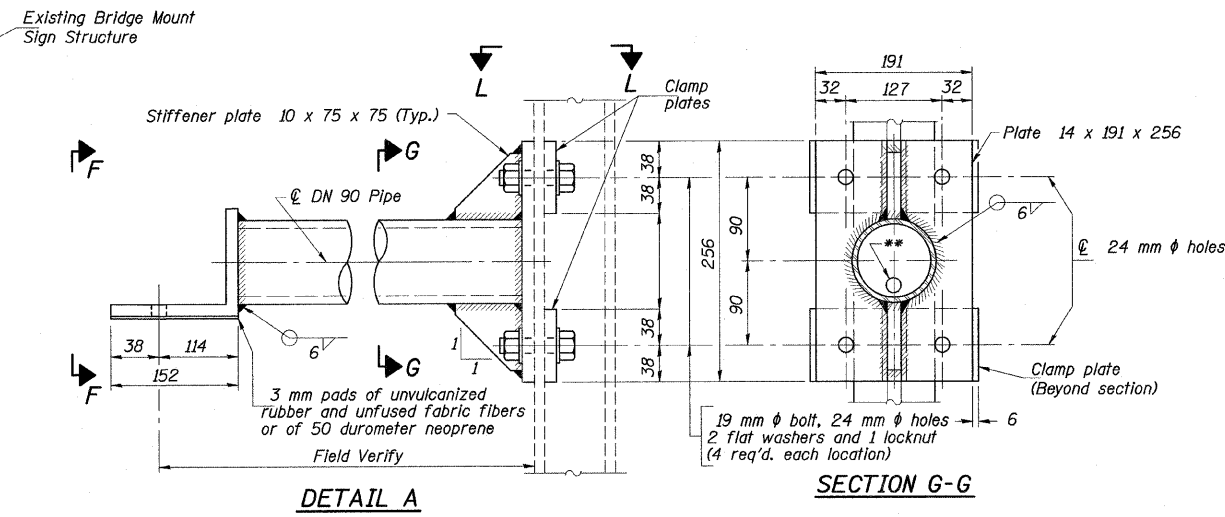

**DETAIL A**

**SECTION G-G**

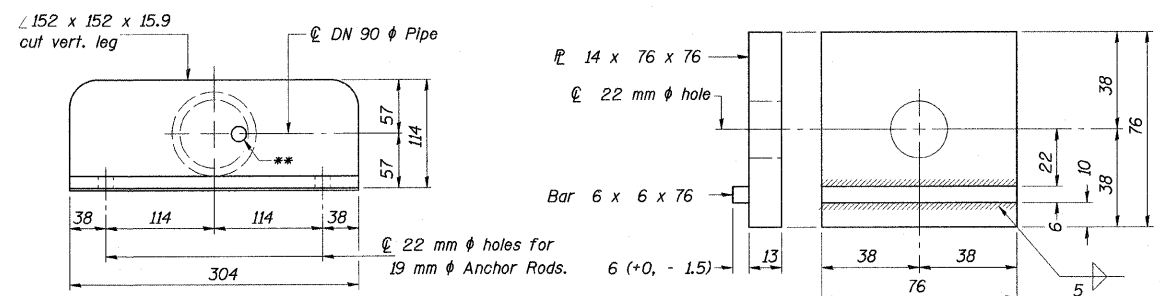

**VIEW F-F**

**CLAMP PLATE DETAILS**

\*\* 21 mm Ø holes for galvanizing. After galvanizing, install M22, A307 hot-dip galvanized bolt to close hole in angle. (No bolt required in 14 mm plate.)

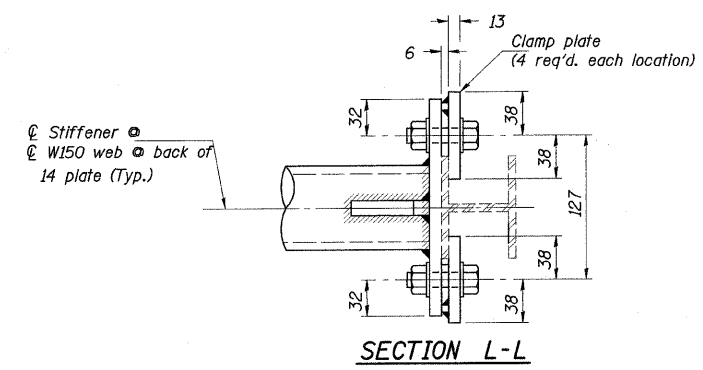

**SECTION L-L**

**BRIDGE MOUNT SIGN STRUCTURE UPPER BRACKET DETAILS**

**NOTES:**

- Existing bridge mounted signs and support systems shall be removed and protected by the Contractor and reinstalled after completion of the new bridge deck and parapet. Any mounting, hardware or brackets damaged during removal, storage and re-erection shall be replaced at no additional cost. Cost for removing, storing and re-erection bridge mounted signs as well as modification to the support brackets or mounting hardware to mount on the new parapets shall be paid for as "Remove, Store and Re-Erect Overhead Sign Structure - Bridge Mounted." Contractor shall coordinate the work with bridge fence railing. Refer to Sheet S11 of S23 for additional information.
- The Contractor is responsible for field verifying the required bracket length and fabricating a bracket extension, as required for Re-Erecting the existing Bridge Mounted signs. Payment will be included in the item "Remove, Store and Re-Erect Overhead Sign Structure-Bridge Mounted." The field verifications shall consider the existing lower bracket and bridge dimensions.
- Contractor shall field check all pertinent existing dimensions before submitting shop drawings.
- Contractor must install upper brackets prior to fence installation.
- All welds to be continuous unless otherwise shown. All welding to be done in accordance with AWS D1.1 Structural Welding Code (Steel) and Standard Specifications.
- All Structural Steel Pipe shall be ASTM A53 Grade B with a minimum yield of 35,000 p.s.i., or A500 B or C with a minimum yield of 46,000 p.s.i. If A500 pipe is substituted for A53, then the outside diameter shall be as detailed and wall thickness greater than or equal to A53.
- All Structural Steel Plates and Shapes shall conform to AASHTO M270 Gr. 36, Gr. 50 (M183, M223, Gr. 50).
- All bolts, washers, nuts and locknuts shall satisfy the requirements of ASTM designation A307 unless noted as "H.S." which shall require AASHTO M164 (A325), ASTM A449, or approved alternate. All fasteners shall be hot dip galvanized per AASHTO M232 unless otherwise specified.
- All Steel Plates, Shapes and Pipe shall be Hot Dip Galvanized after fabrication in accordance with AASHTO M111. Painting is not permitted.
- Anchor rods shall be all-threaded rod conforming to ASTM A307, 3/4" Ø x 12" long, each with one plate washer and locknut and be hot dip galvanized per AASHTO M232. They shall be either cast into the concrete or epoxy grouted in accordance with Section 584 of the Standard Specifications. Minimum embedment in concrete shall be 9".

**COLLINS ENGINEERS**  
123 North Wacker Drive  
Suite 300  
Chicago, IL 60606  
(312) 704-9300  
www.collinseng.com  
ILLINOIS PROFESSIONAL DESIGN FIRM LICENSE NO. 184-00095

REVISIONS	
NAME	DATE

ILLINOIS DEPARTMENT OF TRANSPORTATION  
115 TH. STREET OVER FAI 57  
FAU RTE. 1584 SEC. 068-1919.2-CF  
COOK COUNTY  
STATION 2+382.915  
STRUCTURE NO. 016-2037  
**BRIDGE MOUNT SIGN STRUCTURE CONNECTION DETAILS**  
DRAWN BY BRH  
CHECKED BY JMH  
DATE: JANUARY 16, 2009



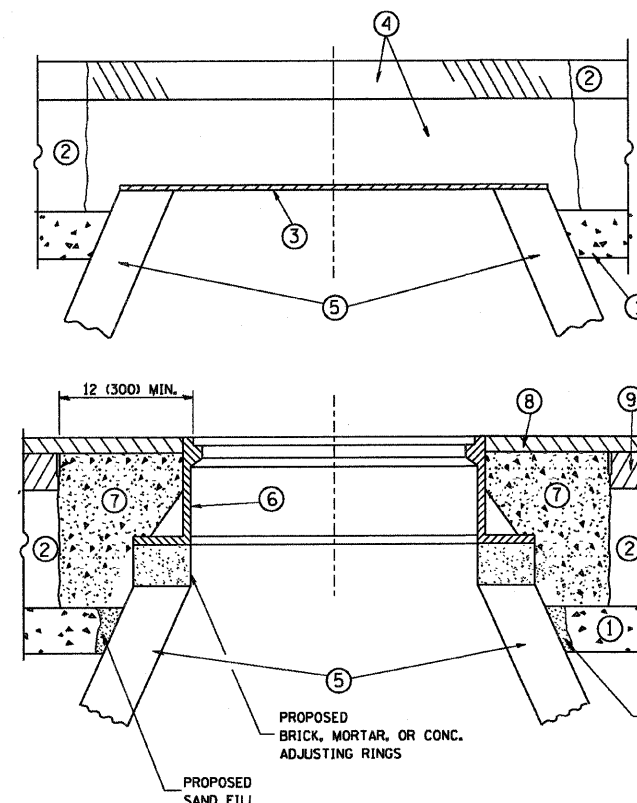

**CONSTRUCTION PROCEDURES**

**STAGE 1 (BEFORE PAVEMENT MILLING)**

- A) REMOVE A MINIMUM OF 12 (300) OF THE PAVEMENT FROM AROUND THE STRUCTURE.
- B) REMOVE THE EXISTING FRAME AND LID FROM THE STRUCTURE.
- C) COVER THE STRUCTURE OPENING WITH A 36 (900) DIAMETER METAL PLATE.
- D) BACKFILL WITH CRUSHED STONE AND A MINIMUM 1 1/2 (40) THICK HMA SURFACE MIX APPROVED BY THE ENGINEER.

**STAGE 2 (AFTER PAVEMENT MILLING)**

- A) REMOVE THE HMA SURFACE MIX AND CRUSHED STONE.
- B) INSTALL THE FRAME AND LID; ADJUST THE FRAME TO ITS FINAL SURFACE ELEVATION.
- C) THE SURROUNDING SPACE SHALL BE FILLED WITH CLASS S1 CONCRETE, OR HMA SURFACE COURSE OR HMA BINDER COURSE TO THE ELEVATION OF THE SURFACE OF THE EXISTING BASE COURSE OR THE BINDER COURSE.

THE PROCEDURE EXPLAINED ABOVE SHALL CONFORM TO THE APPLICABLE PORTIONS OF SECTIONS 353, 406, 602, AND 603 OF THE STANDARD SPECIFICATIONS.

**LEGEND**

- ① SUB-BASE GRANULAR MATERIAL
- ② EXISTING PAVEMENT
- ③ 36 (900) DIAMETER METAL PLATE
- ④ PROPOSED CRUSHED STONE AND HMA SURFACE MIX
- ⑤ EXISTING STRUCTURE
- ⑥ FRAME AND LID (SEE NOTES)
- ⑦ CLASS S1 CONCRETE, HMA SURFACE COURSE OR HMA BINDER COURSE
- ⑧ PROPOSED CRUSHED HMA SURFACE COURSE
- ⑨ PROPOSED HMA BINDER COURSE

**LOCATION OF STRUCTURES:**

THE CONTRACTOR WILL BE REQUIRED TO KEEP A RECORD OF THE LOCATIONS OF THE BURIED STRUCTURES ACCORDING TO THE STATION AND DISTANCE LEFT OR RIGHT OF THE CENTERLINE OF PAVEMENT. UPON COMPLETION OF THE WORK, THE CONTRACTOR WILL DELIVER THE RECORD TO THE ENGINEER.

**BASIS OF PAYMENT:** THIS WORK WILL BE PAID FOR AT THE CONTRACT UNIT PRICE PER EACH FOR "FRAMES AND LIDS TO BE ADJUSTED, SPECIAL"

NEW FRAMES AND LIDS, WHEN SPECIFIED, WILL BE PAID FOR SEPARATELY.

**NOTES:**

EXISTING BROKEN FRAMES AND LIDS SHALL BE REMOVED AND DISPOSED OF BY THE CONTRACTOR AND SHALL BE REPLACED AS DIRECTED BY THE ENGINEER. REPLACEMENT FRAMES AND LIDS WILL BE PAID FOR IN ACCORDANCE WITH ARTICLE 109.04 OF THE STANDARD SPECIFICATIONS UNLESS A SEPARATE PAY ITEM HAS BEEN PROVIDED.

IF THE EXISTING LIDS ARE OPEN, THE FRAME WILL BE ADJUSTED TO THE ELEVATION OF THE MILLED PAVEMENT SURFACE PRIOR TO THE MILLING OPERATION. THE FRAME WILL NOT BE REMOVED AND COVERED BY THE METAL PLATE.

CITY OF CHICAGO CASTINGS ARE THE PROPERTY OF THE CITY AND THE CONTRACTOR SHALL NOTIFY THE CITY FOR REMOVAL AND DISPOSITION OF THE CASTINGS.

THE METAL PLATE USED TO COVER THE STRUCTURE SHALL REMAIN THE PROPERTY OF THE CONTRACTOR.

WHEN STRUCTURES ARE TO BE ADJUSTED OR RECONSTRUCTED, THE LOWERING AND RAISING OF THE FRAMES AND LIDS WILL NOT BE PAID FOR SEPARATELY BUT WILL BE INCLUDED IN THE COST OF THE CORRESPONDING PAY ITEM.

**DETAILS FOR FRAMES AND LIDS ADJUSTMENT WITH MILLING**

ALL DIMENSIONS ARE IN INCHES (MILLIMETERS) UNLESS OTHERWISE SHOWN

FILE NAME = W:\diststd\22x34\bd88.dgn	USER NAME = geglcnobt	DESIGNED - R. SHAH	REVISED - R. SHAH 03-10-95
		DRAWN -	REVISED - A. ABBAS 03-21-97
		CHECKED -	REVISED - R. WIEDEMAN 05-14-04
		DATE - 10-25-94	REVISED - R. BORO 01-01-07

**STATE OF ILLINOIS  
DEPARTMENT OF TRANSPORTATION**

<b>DETAILS FOR FRAMES AND LIDS ADJUSTMENT WITH MILLING</b>			
SCALE: NONE	SHEET NO. 1 OF 1 SHEETS	STA.	TO STA.

F.A. RTE.	SECTION	COUNTY	TOTAL SHEETS	SHEET NO.
57	1919.28	COOK	119	97
BD600-03 (BD-8)			CONTRACT NO. 60371	
FED. ROAD DIST. NO. 1   ILLINOIS   FED. AID PROJECT				

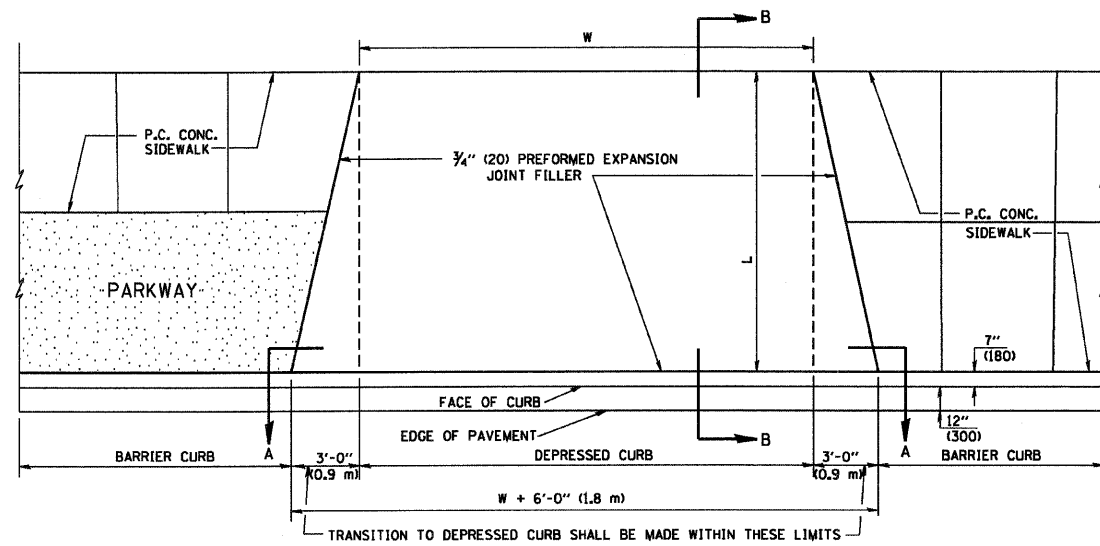

PLAN VIEW

NOTES:

1. EXPANSION JOINTS SHALL BE CONSTRUCTED AS SHOWN ON THE DETAILS FOR P.C.C. SIDEWALK.
2. THE CURB BETWEEN ADJACENT DRIVEWAYS SHALL BE FULL HEIGHT FOR A DISTANCE OF AT LEAST FOUR FEET (1.2 METERS)
3. P.C. CONCRETE DRIVEWAYS SHALL BE CONSTRUCTED AT LOCATIONS SHOWN ON THE PLANS OR AS DIRECTED BY THE ENGINEER.
4. 3/4" (20) PREFORMED EXPANSION JOINTS WILL NOT BE PAID FOR SEPARATELY BUT SHALL BE CONSIDERED INCIDENTAL TO P.C.C. DRIVEWAY PAVEMENT 8" (200).
5. COMBINATION CONC. CURB AND GUTTER SHALL BE MEASURED STRAIGHT ACROSS THE DRIVEWAY. NO ADDITIONAL COMPENSATION WILL BE ALLOWED FOR THE TRANSITION CURB AND GUTTER.

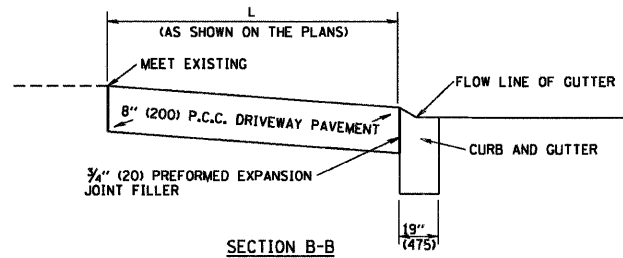

SECTION B-B

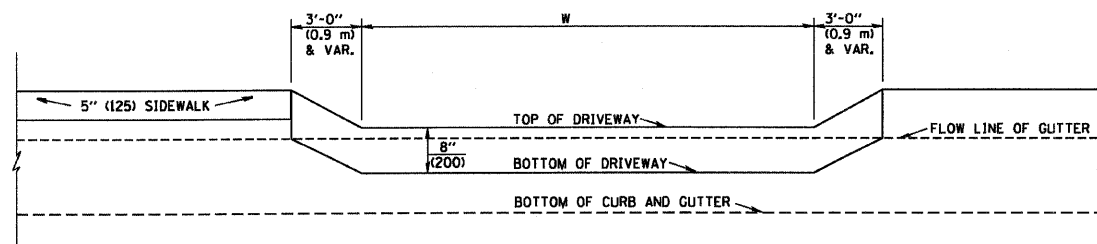

SECTION A-A

P.C.C. DRIVEWAY PAVEMENT DETAIL

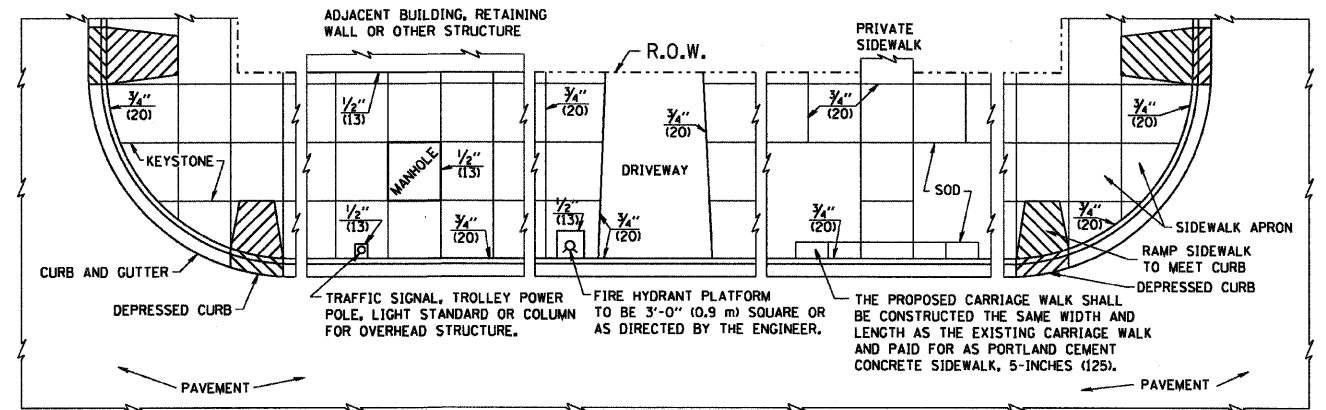

NOTES:

1. ONE-HALF INCH THICK EXPANSION JOINTS SHALL BE PLACED BETWEEN THE SIDEWALK AND ALL STRUCTURES SUCH AS LIGHT STANDARDS, TRAFFIC LIGHT STANDARDS, MANHOLES, WHICH EXTEND THROUGH THE SIDEWALK.
2. 3/4" (20) THICK EXPANSION JOINTS SHALL BE PLACED AT INTERVALS OF NOT MORE THAN 100 FEET (30 METERS) IN THE SIDEWALK. WHERE THE SIDEWALK IS CONSTRUCTED ADJACENT TO PAVEMENT OR CURB HAVING EXPANSION JOINTS, THE EXPANSION JOINTS IN THE SIDEWALK SHALL BE PLACED OPPOSITE THE EXISTING EXPANSION JOINTS AS NEARLY AS PRACTICABLE. EXPANSION JOINTS SHALL ALSO BE PLACED WHERE THE SIDEWALK ABUTS EXISTING SIDEWALKS, BETWEEN DRIVEWAY PAVEMENT AND SIDEWALK, AND BETWEEN SIDEWALK AND CURBS WHERE THE SIDEWALK ABUTS A CURB.

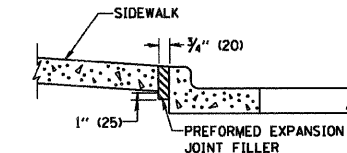

SLOPE FOR SIDEWALK  
1" (25) IN 3'-0" (0.9 m) IN CHICAGO

PORTLAND CEMENT CONCRETE SIDEWALK DETAILS

NOTES: NO EXTRA COMPENSATION SHALL BE ALLOWED FOR THE GUTTER FLARE

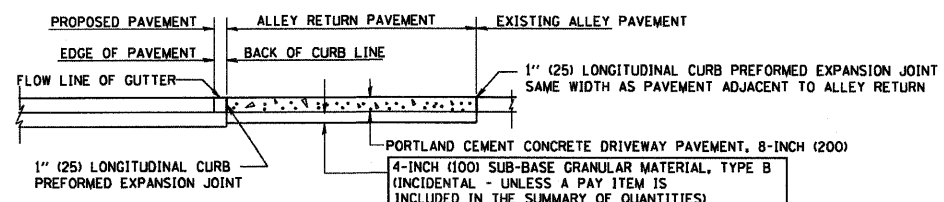
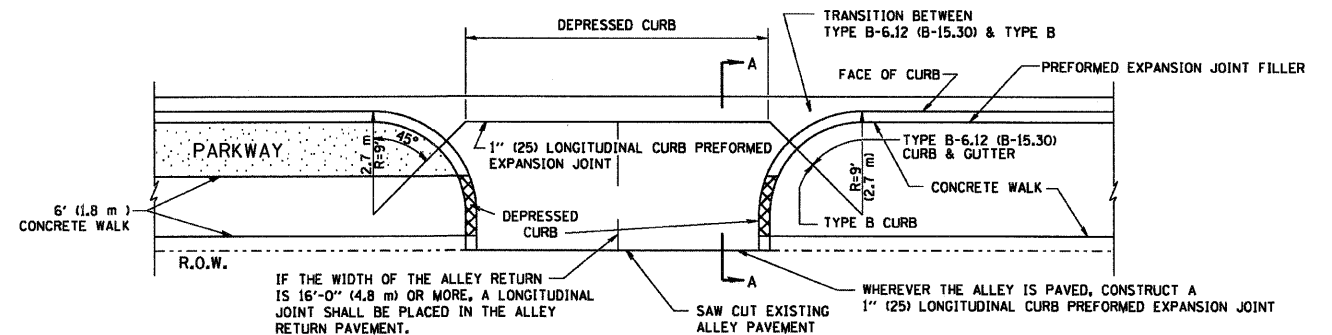

SECTION A-A

ALLEY RETURN DETAIL

ALL DIMENSIONS ARE IN INCHES (MILLIMETERS) UNLESS OTHERWISE SHOWN

FILE NAME = W:\dstest\22x34\bd17.dgn	USER NAME = geglino	DESIGNED - M. DE YONG	REVISED -
		DRAWN -	REVISED -
		CHECKED -	REVISED -
		DATE - 06-13-90	REVISED -

STATE OF ILLINOIS  
DEPARTMENT OF TRANSPORTATION

CITY OF CHICAGO  
DETAILS FOR P.C. CONCRETE DRIVEWAY, ALLEY RETURN AND SIDEWALK

F.A. RTE. 57	SECTION 1919.28	COUNTY COOK	TOTAL SHEETS 119	SHEET NO. 98
BD400-03 (BD-17)		CONTRACT NO. 60371		
FED. ROAD DIST. NO. 1 ILLINOIS FED. AID PROJECT				

SCALE: NONE SHEET NO. 1 OF 1 SHEETS STA. TO STA.

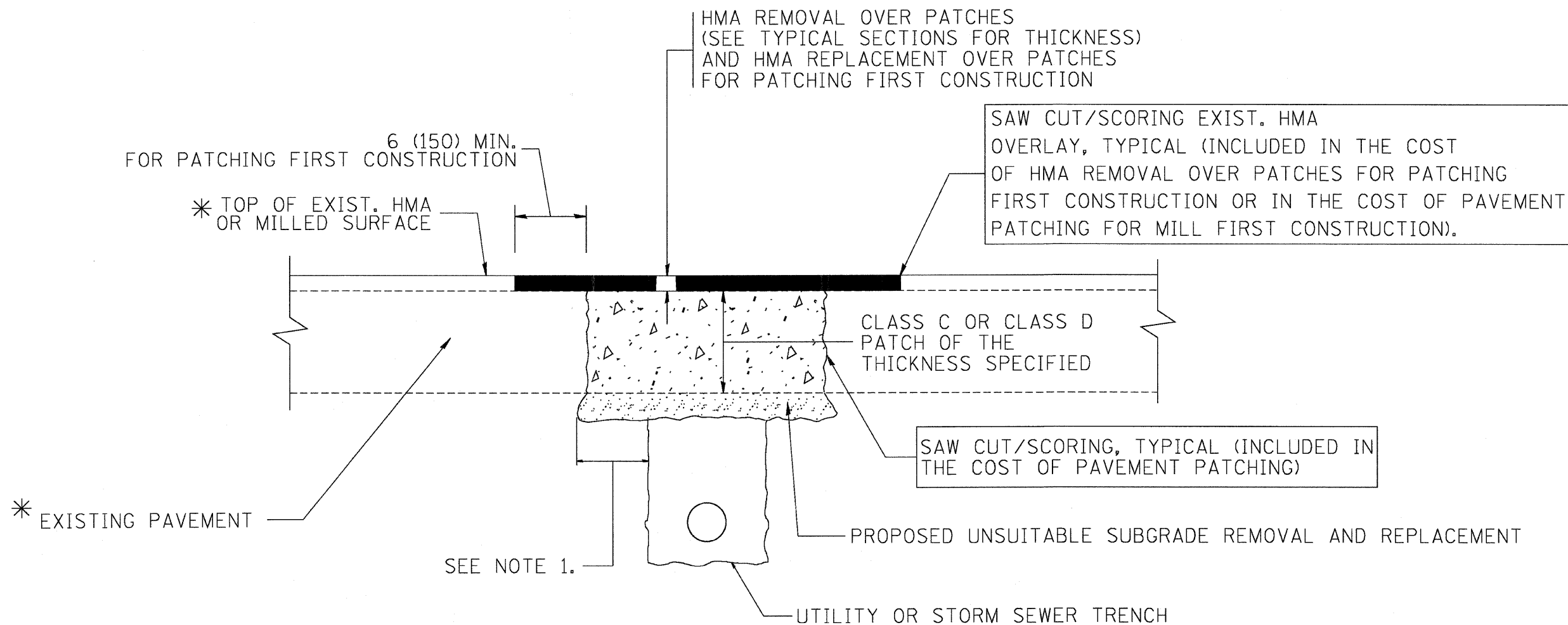

\* SEE TYPICAL SECTIONS FOR THICKNESS AND MATERIALS

**NOTES:**

1. THE WIDTH OF THE FULL DEPTH PATCH OVER A TRENCH SHALL BE 12 (300) WIDER ON EACH SIDE OF THE TRENCH.
2. FOR METHOD OF MEASUREMENT AND BASIS OF PAYMENT, SEE RECURRING SPECIAL PROVISION "PATCHING WITH HOT-MIX ASPHALT OVERLAY REMOVAL".

**SEQUENCE OF CONSTRUCTION (PATCHING FIRST)**

1. REMOVE THE EXISTING HMA MATERIAL OVER THE AREA TO BE PATCHED.
2. REMOVE AND REPLACE WITH CLASS C OR D PATCH.
3. REPLACE HMA MATERIAL OVER THE AREA TO BE PATCHED.

**SEQUENCE OF CONSTRUCTION (MILLING FIRST)**

1. MILL HMA FIRST IF THERE IS AT LEAST 4 1/2 INCHES OR MORE OF HMA MATERIAL ON TOP OF THE EXISTING PAVEMENT OR IF THE PAVEMENT IS FULL DEPTH HMA. A MINIMUM OF 2 INCHES OF HMA MATERIAL SHALL BE IN PLACE AFTER MILLING.
2. REMOVE AND REPLACE WITH FULL DEPTH CLASS D PATCHES TO TOP OF MILLED SURFACE.

ALL DIMENSIONS ARE IN INCHES (MILLIMETERS) UNLESS OTHERWISE SHOWN.

FILE NAME = c:\projects\diststd22x34\bd22.dgn	USER NAME = bouerd1	DESIGNED - R. SHAH	REVISED - A. ABBAS 04-27-98	<b>STATE OF ILLINOIS DEPARTMENT OF TRANSPORTATION</b>	<b>PAVEMENT PATCHING FOR HMA SURFACED PAVEMENT</b>			F.A.I. RTE.	SECTION	COUNTY	TOTAL SHEETS	SHEET NO.
		DRAWN -	REVISED - R. BORO 01-01-07		57	1919.28	COOK	119	99			
		CHECKED -	REVISED - R. BORO 09-04-07		<b>BD400-04 (BD-22)</b>			CONTRACT NO. 60371				
		DATE - 10-25-94	REVISED - K. ENG 10-27-08		SCALE: NONE	SHEET NO. 1 OF 1 SHEETS	STA. TO STA.	FED. ROAD DIST. NO. 1 ILLINOIS FED. AID PROJECT				



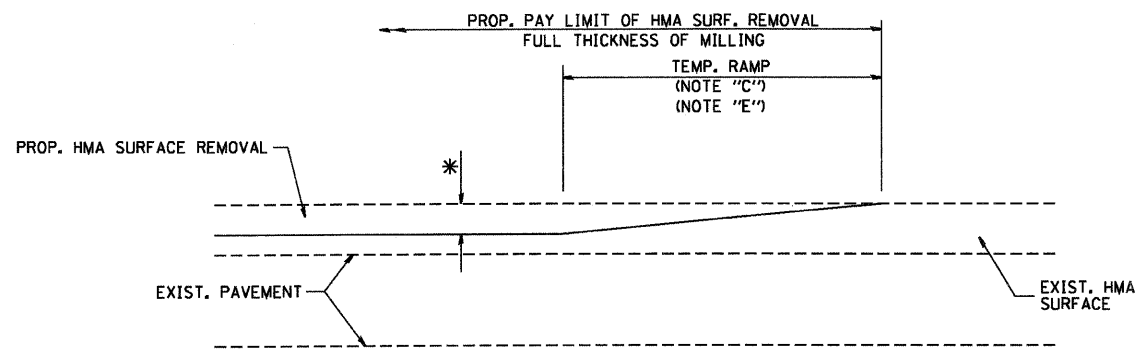

MILLED TEMPORARY RAMP  
(FOR BUTT JOINT AND HMA TAPER SEE DETAIL BELOW)

**OPTION 1**

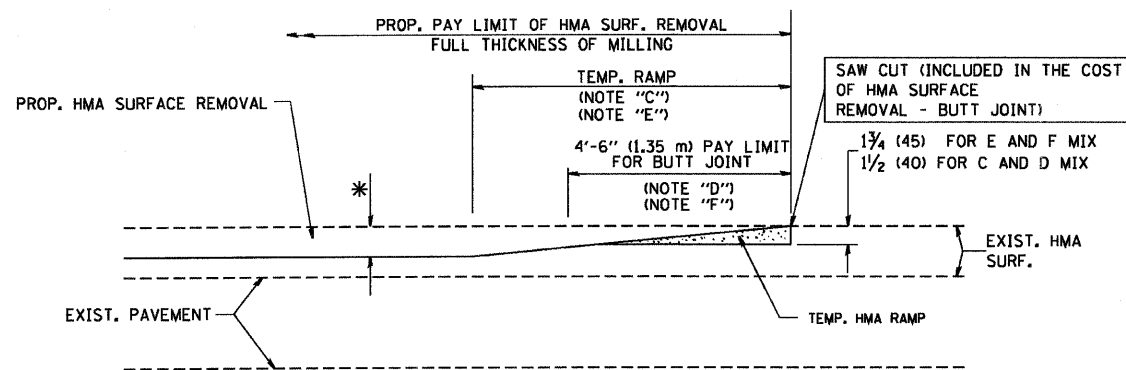

HMA CONSTRUCTED TEMPORARY RAMP  
(FOR BUTT JOINT AND HMA TAPER SEE DETAIL BELOW)

**OPTION 2**  
**TYPICAL TEMPORARY RAMP**

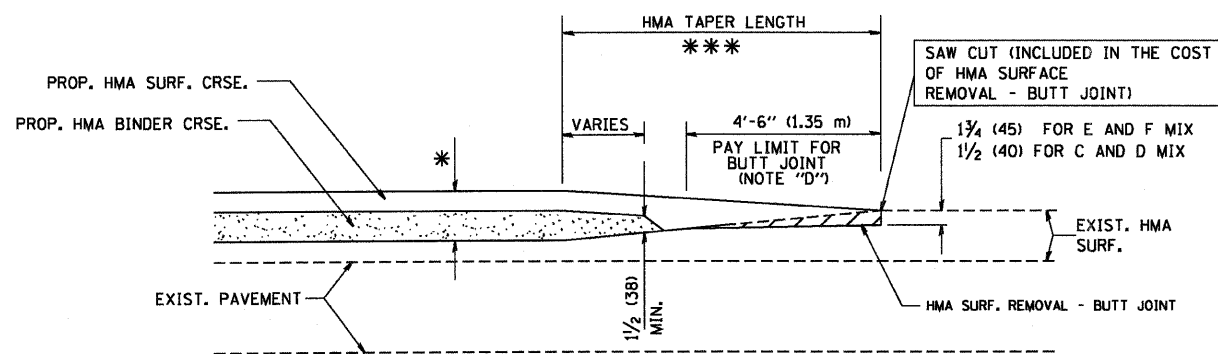

BUTT JOINT AND HMA TAPER  
**TYPICAL BUTT JOINT AND HMA TAPER FOR MILLING AND RESURFACING**

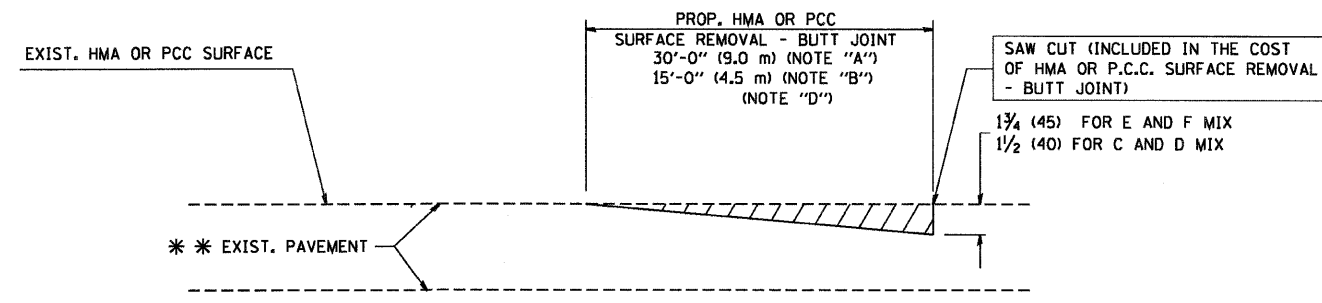

BUTT JOINT DETAIL

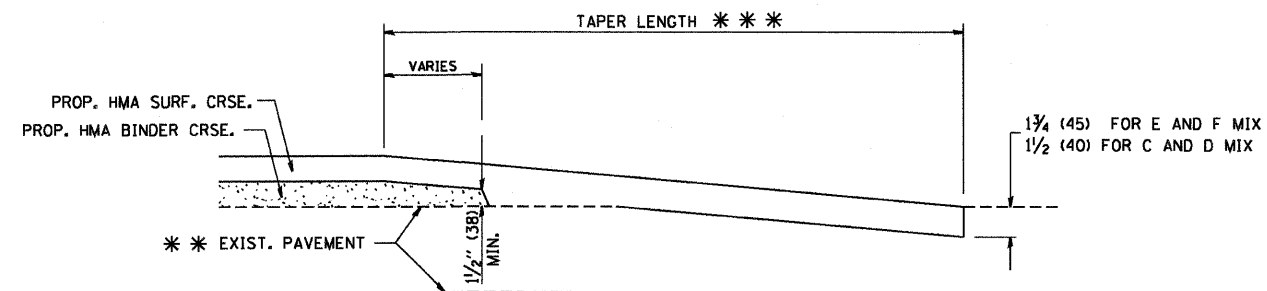

HMA TAPER DETAIL

**TYPICAL BUTT JOINT AND HMA TAPER FOR RESURFACING ONLY**

\*\*\* PC CONCRETE, HMA OR HMA RESURFACED PAVEMENT.

**NOTES**

- A: MAINLINE ROADWAYS AND MAJOR SIDE ROADS.
  - B: MINOR SIDE ROADS.
  - C: THE TEMP. RAMP SHALL BE CONSTRUCTED IMMEDIATELY UPON REMOVAL OF THE EXISTING HMA SURFACE.
  - D: THE BUTT JOINT SHALL BE CONSTRUCTED IMMEDIATELY PRIOR TO PLACING THE PROPOSED HMA COURSES.
  - E: TAPER THE TEMP. RAMP AT A RATE OF 3'-0" (900 mm) PER 1 INCH (25 mm) OF MILLING THICKNESS.
  - F: INSTALLATION AND REMOVAL OF THE 4'-6" (1.35 m) TEMP. RAMP IS INCLUDED IN COST OF HMA SURFACE REMOVAL - BUTT JOINT
  - G: SEE ARTICLE 406.08 AND 406.14 OF THE STANDARD SPECIFICATIONS FOR "HMA AND/OR PCC SURFACE REMOVAL, BUTT JOINT".
- \* SEE TYPICAL SECTIONS FOR MILLING THICKNESS.
- \*\*\* 20'-0" (6.1 m) PER 1 (25) RESURFACING (NOTE "A")  
10'-0" (3.0 m) PER 1 (25) RESURFACING (NOTE "B")

**BASIS OF PAYMENT:**

THE BUTT JOINT WILL BE PAID FOR AT THE CONTRACT UNIT PRICE PER SQUARE YARD (SQUARE METER) FOR "HOT-MIX ASPHALT SURFACE REMOVAL - BUTT JOINT" OR FOR "PORTLAND CEMENT CONCRETE SURFACE REMOVAL - BUTT JOINT".

ALL DIMENSIONS ARE IN INCHES (MILLIMETERS) UNLESS OTHERWISE SHOWN.

FILE NAME = W:\distsd\22x34\bd32.dgn	USER NAME = goglienobt	DESIGNED - M. DE YONG	REVISED - R. SHAH 10-25-94
		DRAWN -	REVISED - A. ABBAS 03-21-97
	PLOT SCALE = 50.0000' / IN.	CHECKED -	REVISED - M. GOMEZ 04-06-01
	PLOT DATE = 1/4/2008	DATE - 06-13-90	REVISED - R. BORO 01-01-07

**STATE OF ILLINOIS  
DEPARTMENT OF TRANSPORTATION**

<b>BUTT JOINT AND HMA TAPER DETAILS</b>		F.A. RTE.	SECTION	COUNTY	TOTAL SHEETS	SHEET NO.
SCALE: NONE		57	1919.28	COOK	119	101
SHEET NO. 1 OF 1 SHEETS		BD400-05 BD32		CONTRACT NO. 60371		
STA. TO STA.		FED. ROAD DIST. NO. 1 ILLINOIS FED. AID PROJECT				

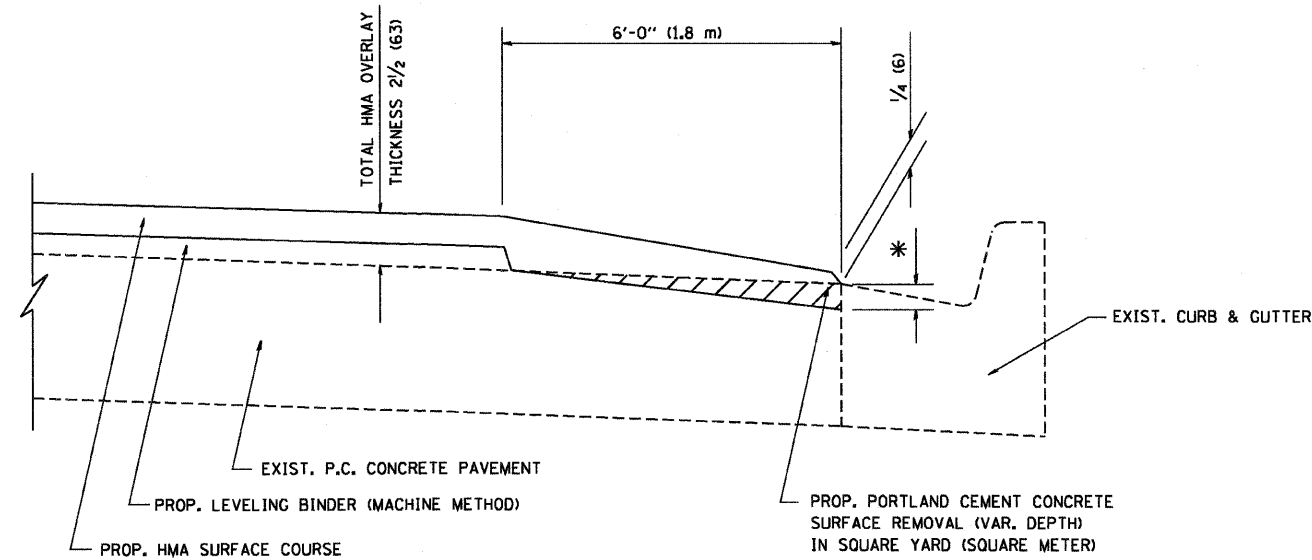

**HMA TAPER AT  
EDGE OF P.C.C. PAVEMENT**

HMA SURFACE	LEVELING BINDER	* MILLING AT GUTTER FLAG
MIX	THICKNESS	THICKNESS
C OR D	1/2 (38)	1 (25)
F	1 1/4 (44)	3/4 (19)

ALL DIMENSIONS ARE IN INCHES (MILLIMETERS) UNLESS OTHERWISE SHOWN.

FILE NAME = W:\diststd\22x34\bd33.dgn	USER NAME = geglienobt	DESIGNED - R. SHAH	REVISED - R. SHAH 10-25-94
		DRAWN - JIS	REVISED - A. ABBAS 05-05-99
		CHECKED - A. ABBAS	REVISED - E. GOMEZ 12-21-00
		DATE - 09-10-94	REVISED - R. BORO 01-01-07

**STATE OF ILLINOIS  
DEPARTMENT OF TRANSPORTATION**

<b>HMA TAPER AT EDGE OF P.C.C. PAVEMENT</b>			
SCALE: NONE	SHEET NO. 1 OF 1 SHEETS	STA.	TO STA.

F.A. RTE.	SECTION	COUNTY	TOTAL SHEETS	SHEET NO.
57	1919.28	COOK	119	102
BD400-06 (BD33)		CONTRACT NO. 60371		
FED. ROAD DIST. NO. 1 ILLINOIS FED. AID PROJECT				

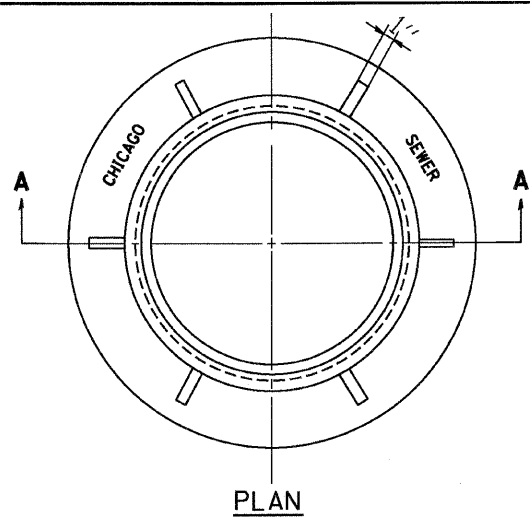

PLAN

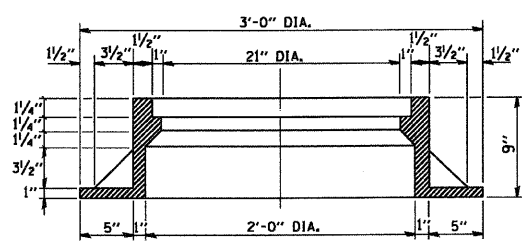

SECTION A-A

NOTE: METAL PLATES MUST BE FURNISHED FOR PERFORATED LIDS ON MANHOLES

CHICAGO STANDARD MANHOLE FRAME  
SCALE: 1/2"=1'-0"  
MATERIAL: CAST IRON

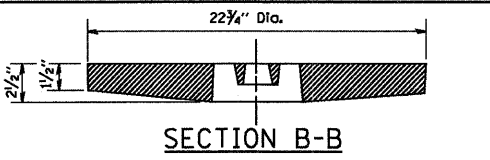

SECTION B-B

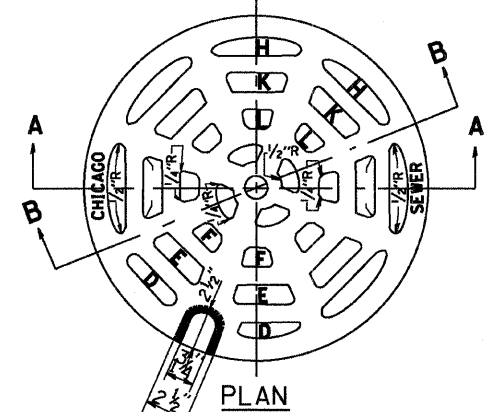

PLAN

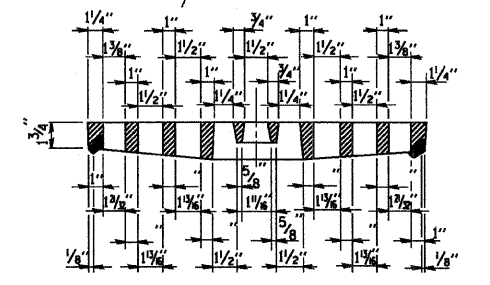

SECTION A-A

PERFORATED LID FOR CATCH BASINS & MANHOLES  
SCALE: 2"=1'-0"  
MATERIAL: CAST IRON

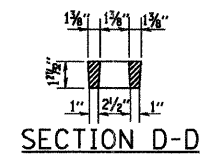

SECTION D-D

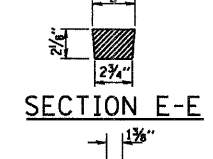

SECTION E-E

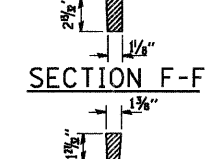

SECTION F-F

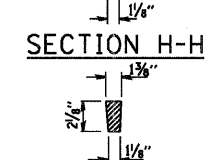

SECTION H-H

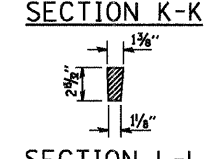

SECTION K-K

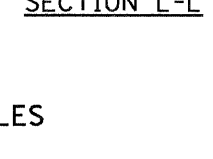

SECTION L-L

SOLID LID FOR MANHOLES  
SCALE: NONE  
MATERIAL: CAST IRON

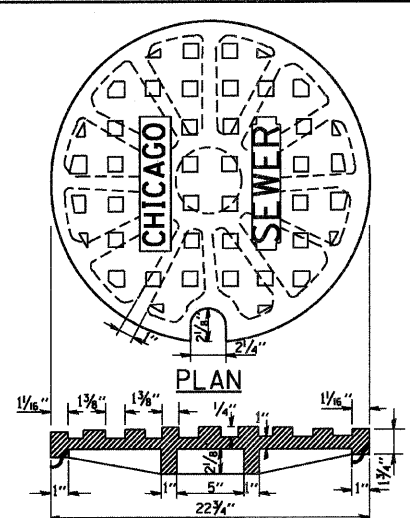

PLAN

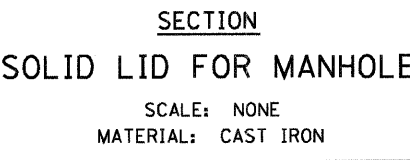

SECTION

SOLID LID FOR MANHOLES  
SCALE: NONE  
MATERIAL: CAST IRON

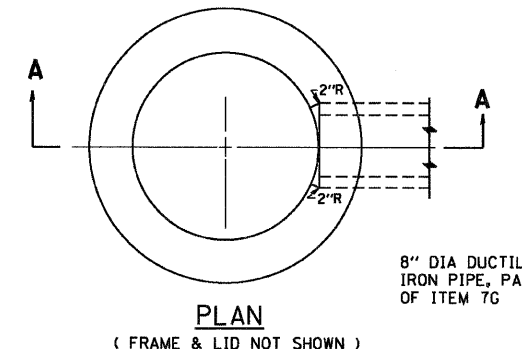

PLAN

(FRAME & LID NOT SHOWN)

8" DIA DUCTILE IRON PIPE, PART OF ITEM 7G

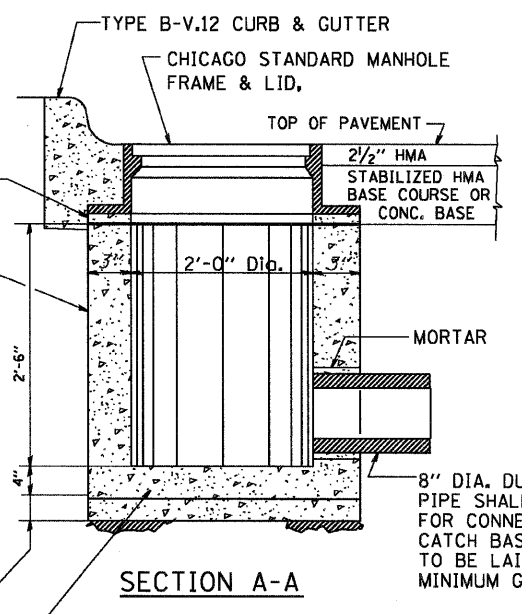

SECTION A-A

REINFC. CONC. BASE CAST AS INTEGRAL PART OF 24" DIA. PRECAST CONC. RING  
6" MINIMUM GRANULAR EMBEDMENT UNDER ALL INLETS. FURNISHING AND INSTALLING GRANULAR EMBEDMENT SHALL BE INCLUDED IN THE UNIT PRICE BID FOR ITEM 12

STANDARD INLETS  
SCALE 1"=1'-0"  
ITEM 12

THIS INLET DETAIL IS SOMETIMES REFERRED TO AS "CHICAGO STANDARD INLET, TYPE A"

NOTE: INLETS SHALL NOT BE CONSTRUCTED UNLESS IT IS IMPOSSIBLE TO CONSTRUCT A CATCH BASIN. THE CONTRACTOR SHALL HAVE THE DEPARTMENT OF SEWERS APPROVAL BEFORE CONSTRUCTING INLETS.

CITY OF CHICAGO  
DEPARTMENT OF SEWERS  
ENGINEERING DIVISION

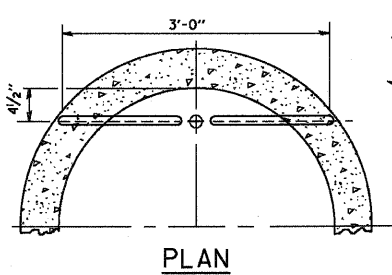

PLAN

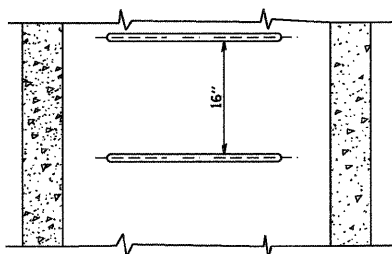

ELEVATION  
TYPE X  
SCALE: 1"=1'-0"

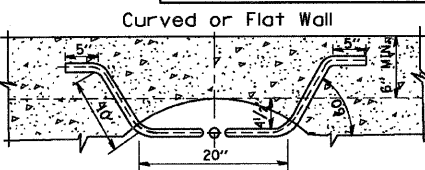

PLAN

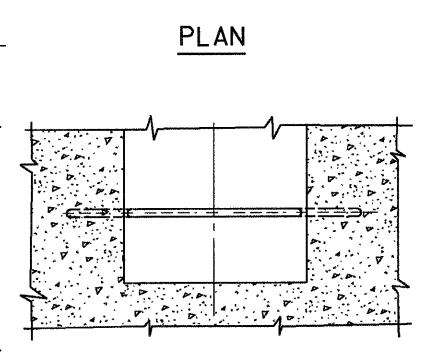

ELEVATION  
TYPE Y  
SCALE: 1"=1'-0"

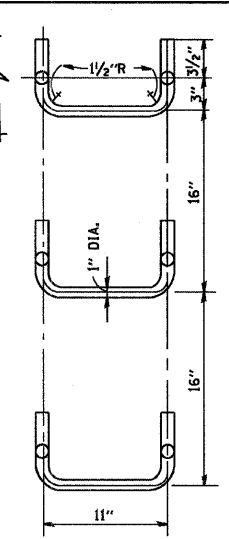

SPACING  
HANDHOLD-TYPE Z RUNG  
Scale: 1/2"=1'-0"

STANDARD LADDER RUNGS  
ALL LADDER RUNGS SHALL BE ALUMINUM OR GALVANIZED WROUGHT IRON AS SPECIFIED IN THE SPECIFICATIONS, PART 2, ARTICLE 214.2. RUNGS SHALL BE 1" DIAMETER OR OF A SHAPE HAVING AN EQUIVALENT CROSS-SECTIONAL AREA.

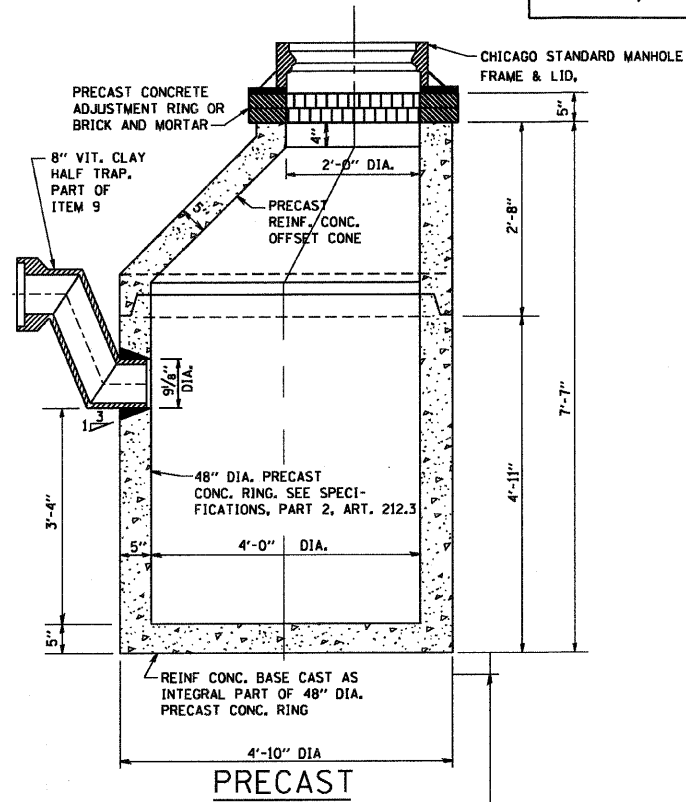

PRECAST

NOTE: 6" MINIMUM GRANULAR EMBEDMENT UNDER ALL CATCH BASINS

STANDARD CATCH BASINS  
SCALE: 3/4"=1'-0"  
ITEM 9

FILE NAME = W:\datatd\22x34\bd47.dgn	USER NAME = geglienob	DESIGNED - M. GOMEZ	REVISED -	STATE OF ILLINOIS DEPARTMENT OF TRANSPORTATION	CITY OF CHICAGO CATCH BASIN, INLET AND MANHOLE DETAILS	F.A. RTE.	SECTION	COUNTY	TOTAL SHEETS	SHEET NO.
PLOT SCALE = 58.8888' / IN.	CHECKED -	REVISOR -	57			1919.28	COOK	119	103	
PLOT DATE = 1/4/2008	DATE - 01-25-01	REVISOR -	BD600-13 (BD47)			CONTRACT NO. 60371				
			FED. ROAD DIST. NO. 1 ILLINOIS FED. AID PROJECT							

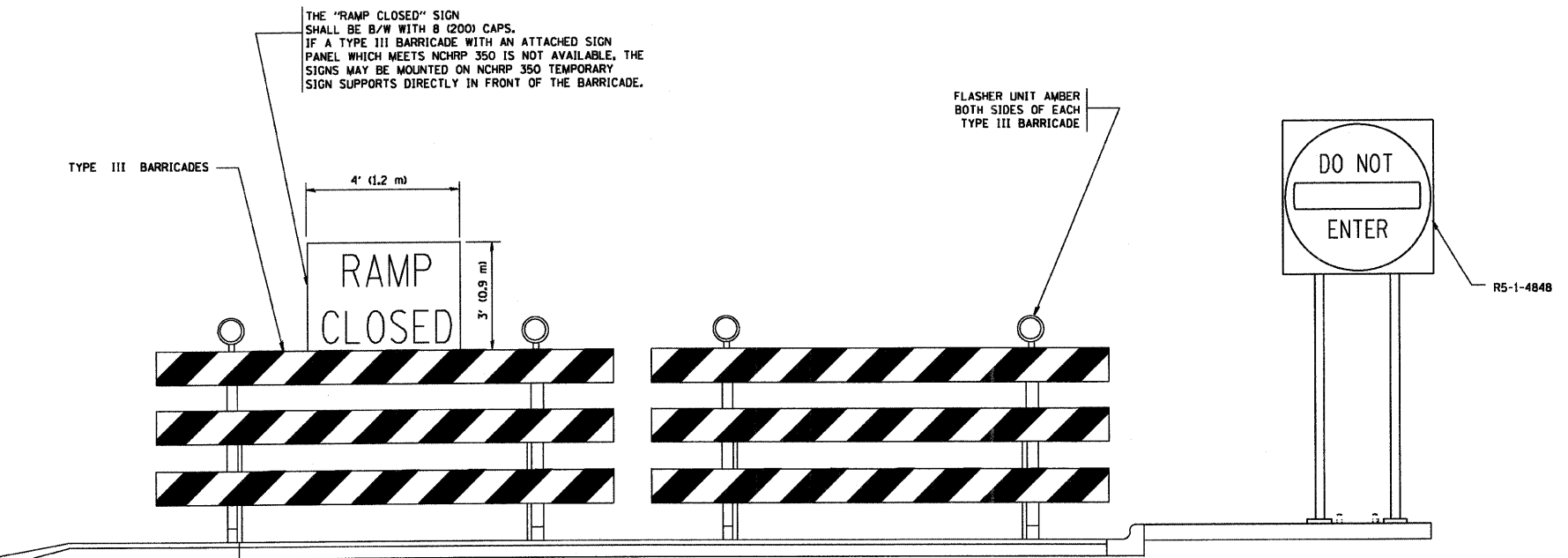
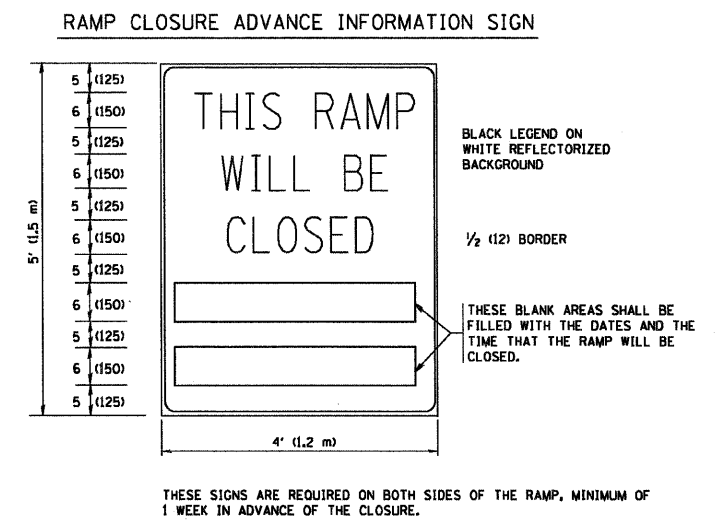
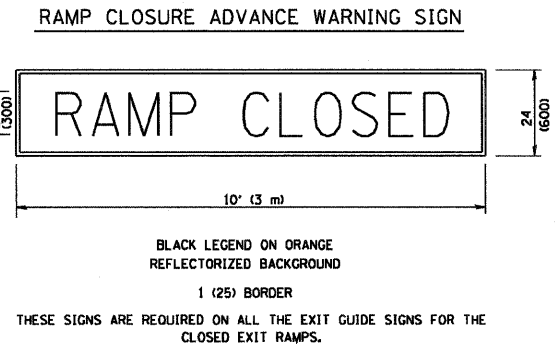
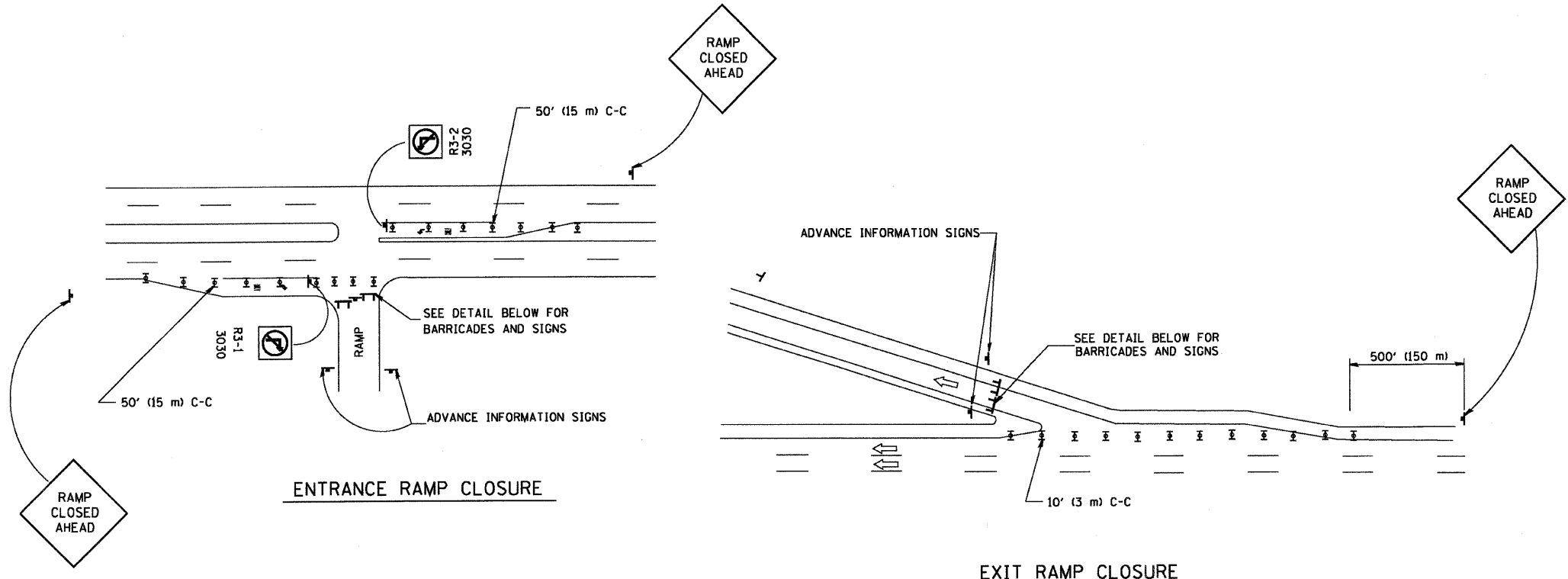

DETAIL FOR REQUIRED BARRICADES & SIGNS

- SYMBOLS**
- ⊞ TYPE II BARRICADE, DRUM OR VERTICAL BARRICADE WITH STEADY BURN MONO-DIRECTIONAL LIGHT
  - ⊞ TYPE III BARRICADE WITH FLASHING LIGHT

- GENERAL NOTES:**
1. CONES MAY BE SUBSTITUTED FOR DRUMS OR TYPE II BARRICADES DURING DAY OPERATIONS. CONES SHALL BE A MINIMUM OF 28 (700) HIGH.
  2. STEADY BURN LIGHTS WILL NOT BE REQUIRED FOR DAY OPERATIONS.
  3. A FLAGGER SHALL BE POSITIONED AT EACH CLOSED RAMP THAT IS OPEN TO CONSTRUCTION VEHICLES.
  4. ALL ROUTE MARKERS AND TRAILBLAZER ASSEMBLIES WHICH DIRECT MOTORISTS TO A CLOSED ENTRANCE RAMP SHALL BE COVERED.
  5. THE SIGNING AND BARRICADING WHICH IS REQUIRED BY THIS DETAIL SHALL BE INCLUDED IN THE COST OF TRAFFIC CONTROL AND PROTECTION (EXPRESSWAYS).
  6. AUTHORIZATION FROM THE DISTRICT'S BUREAU OF TRAFFIC IS REQUIRED FOR ALL RAMP CLOSURES.
  7. THE RAMP CLOSURE ADVANCE INFORMATION SIGNS SHALL BE ERECTED IF THE CLOSURE TIME EXCEEDS TWENTY-FOUR (24) HOURS. ADDITIONAL ADVANCE WARNING SIGNS ON EXIT GUIDE SIGNING WILL BE REQUIRED FOR EXIT RAMP CLOSURES THAT EXCEED TWENTY FOUR (24) HOURS IN LENGTH.

ALL DIMENSIONS ARE IN INCHES (MILLIMETERS) UNLESS OTHERWISE SHOWN.

FILE NAME = W:\d\statd\22x34\to88.dgn	USER NAME = geglianobt	DESIGNED - DWS	REVISED - DWS 12-94	<b>STATE OF ILLINOIS DEPARTMENT OF TRANSPORTATION</b>	<b>FREEWAY ENTRANCE AND EXIST RAMP CLOSURE DETAILS</b>			F.A. RTE.	SECTION	COUNTY	TOTAL SHEETS	SHEET NO.
	PLOT SCALE = 50,000 / IN.	CHECKED -	REVISED - DWS/JAF 12-02		57	1919.28	COOK	119	104			
PLOT DATE = 1/4/2008	DATE - 02-83	REVISED - JAF 02-06	REVISED - SPB 01-07	SCALE: NONE	SHEET NO. 1 OF 1 SHEETS	STA.	TO STA.	TC-08	CONTRACT NO. 60371			
								FED. ROAD DIST. NO. 1 ILLINOIS FED. AID PROJECT				



# SINGLE LANE WEAVE

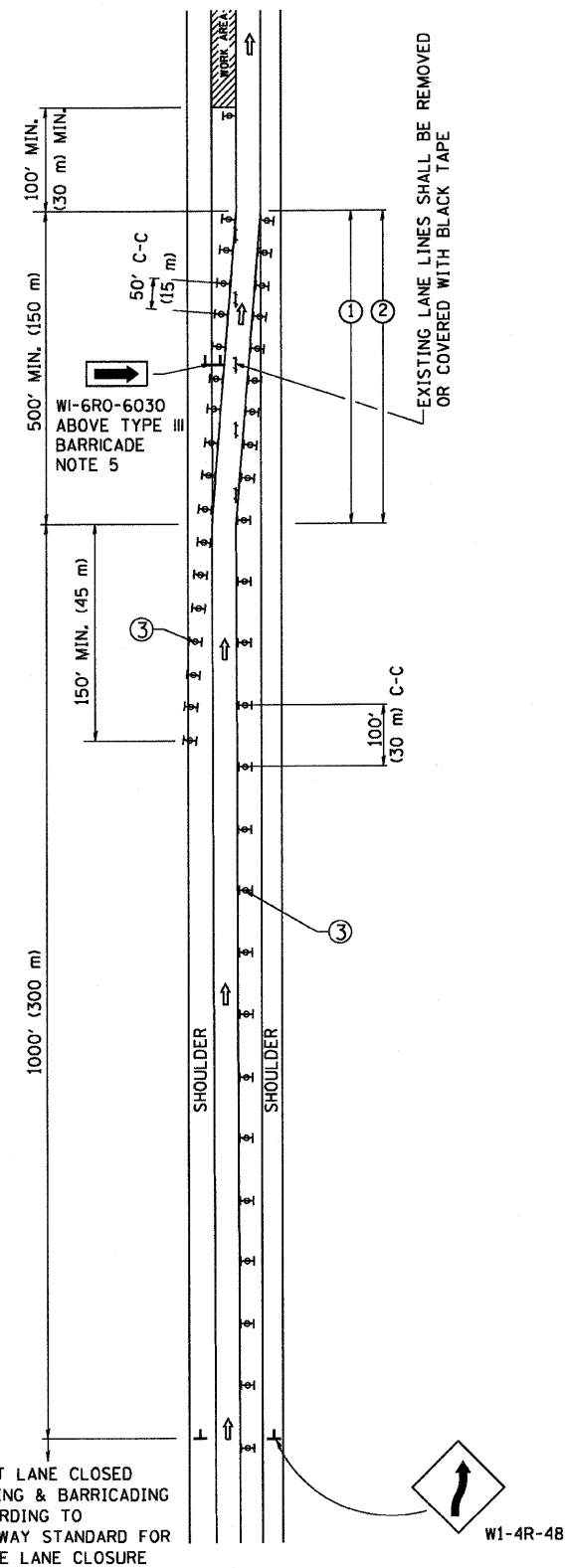

# MULTI-LANE WEAVE

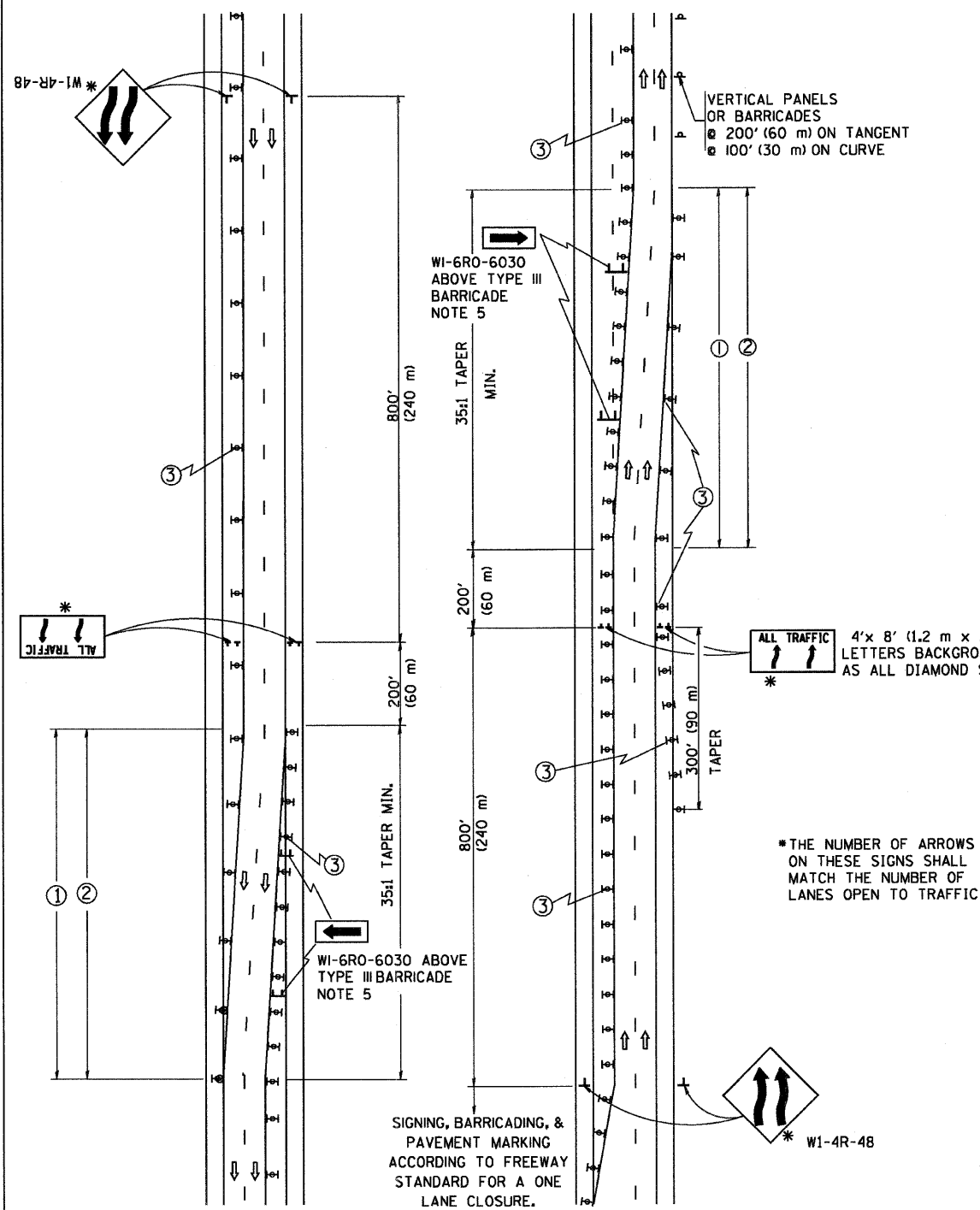

### GENERAL NOTES

- EXISTING CONFLICTING PAVEMENT MARKING LINES SHALL BE REMOVED OR COVERED WITH BLACK TAPE. PAVEMENT MARKING REMOVAL OR BLACK TAPE SHALL NOT BE REQUIRED FOR LANE CLOSURES UNDER 24 HOURS IN DURATION.
- CONTINUOUS REFLECTIVE TEMPORARY PAVEMENT MARKING TAPE SHALL BE PLACED THROUGHOUT THE TAPER AND FOR 300' (90 m) ALONG SIDE THE WORK AREA WHERE THE CLOSURE TIME IS GREATER THAN FOURTEEN DAYS. THE LEFT EDGE LINE SHALL BE YELLOW AND THE RIGHT EDGE LINE SHALL BE WHITE. FOR MULTI-LANE WEAVE LANE LINES SHALL BE 10'-30' (3 m-9 m) SKIP DASH, WHITE.
- PLASTIC DRUMS WITH STEADY BURN LIGHTS AT 50' (15 m) C-C SPACING IN TAPERS AND 100' (30 m) C-C SPACING IN TANGENTS.
- ALL SIGNS SHALL BE POST MOUNTED IF THE CLOSURE TIME EXCEEDS FOUR DAYS.
- IF A TYPE III BARRICADE WITH AN ATTACHED SIGN PANEL WHICH MEETS NCHRP 350 IS NOT AVAILABLE, THE SIGNS MAY BE MOUNTED ON NCHRP 350 TEMPORARY SIGN SUPPORTS DIRECTLY IN FRONT OF THE BARRICADE.
- IF THE WIDTH OF OFFSET IS LESS THAN 6' THEN THE TYPE III BARRICADE WITH ATTACHED ARROW SIGN PANEL CAN BE ELIMINATED IN THE TAPER AREAS.

### SYMBOLS

- ↑ DIRECTION OF TRAFFIC
- ▨ WORK AREA
- ⊥ SIGN ON PORTABLE OR PERMANENT SUPPORT
- ⊥ TYPE II BARRICADE, DRUM OR VERTICAL BARRICADE WITH MONO-DIRECTIONAL STEADY BURNING LIGHT

ALL DIMENSIONS ARE IN INCHES (MILLIMETERS) UNLESS OTHERWISE SHOWN

FILE NAME = W:\diststd\22x34\to09.dgn

USER NAME = geglanobt  
 PLOT SCALE = 50.000 / IN.  
 PLOT DATE = 1/4/2008

DESIGNED - DWS  
 DRAWN -  
 CHECKED -  
 DATE - 02-87

REVISED - DWS 11-96  
 REVISED - JAF 01-03  
 REVISED - JAF 02-06  
 REVISED - SPB 01-07

STATE OF ILLINOIS  
 DEPARTMENT OF TRANSPORTATION

TRAFFIC CONTROL DETAILS FOR  
 FREEWAY SINGLE & MULTI-LANE WEAVE

SCALE: NONE SHEET NO. 1 OF 1 SHEETS STA. TO STA.

F.A. RTE.	SECTION	COUNTY	TOTAL SHEETS	SHEET NO.
57	1919,28	COOK	119	105
TC-09			CONTRACT NO. 60371	
FED. ROAD DIST. NO. 1 ILLINOIS FED. AID PROJECT				

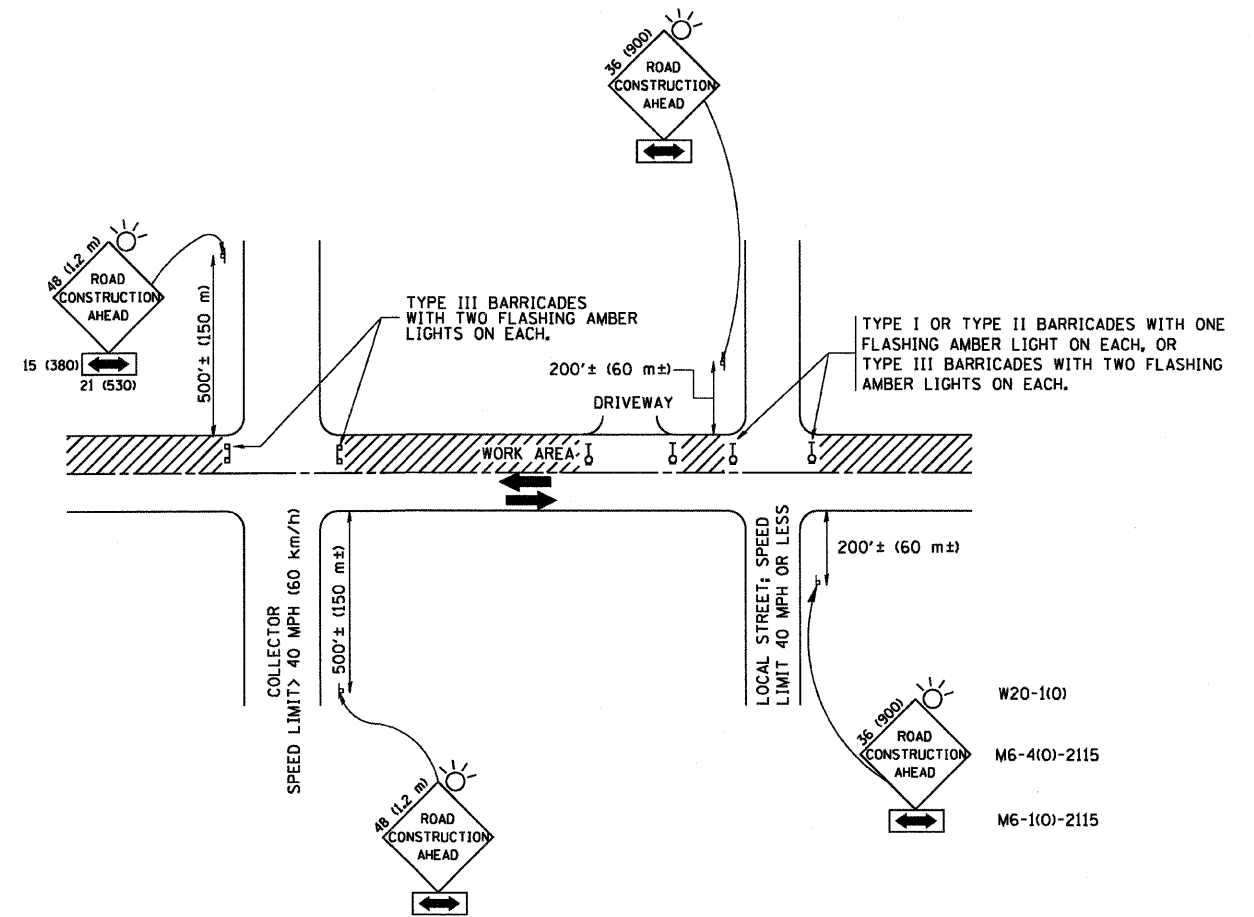

TRAFFIC CONTROL AND PROTECTION FOR SIDE ROADS, INTERSECTIONS, AND DRIVEWAYS

NOTES:

- A. FOR NO LANE RESTRICTION ON THE SIDE ROAD OR DRIVEWAYS
  1. SIDE ROAD WITH A SPEED LIMIT OF 40 MPH (60 km/h) OR LESS AS SHOWN ON THE DRAWING AND AS DIRECTED BY THE ENGINEER:
    - a) ONE ROAD CONSTRUCTION AHEAD SIGN 36 x 36 (900x900) WITH A FLASHER AND FLAG MOUNTED ON IT APPROXIMATELY 200' (60 m) IN ADVANCE OF THE MAIN ROUTE.
    - b) THE CLOSED PORTION OF THE MAIN ROUTE SHALL BE PROTECTED BY BLOCKING WITH TYPE I, TYPE II OR TYPE III BARRICADES, 1/3 OF THE CROSS SECTION OF THE CLOSED PORTION.
  2. SIDE ROAD WITH A SPEED LIMIT GREATER THAN 40 MPH (60 km/h) AS SHOWN ON THE DRAWING AND AS DIRECTED BY THE ENGINEER:
    - a) ONE ROAD CONSTRUCTION AHEAD SIGN 48 x 48 (1.2 m x 1.2 m) WITH A FLASHER MOUNTED ON IT APPROXIMATELY 500' (150 m) IN ADVANCE OF THE MAIN ROUTE.
    - b) THE CLOSED PORTION OF THE MAIN ROUTE SHALL BE PROTECTED BY BLOCKING WITH TYPE III BARRICADES, 1/2 OF THE CROSS SECTION OF THE CLOSED PORTION.
  3. WHEN THE SIDE ROAD LIES BETWEEN THE BEGINNING OF THE MAINLINE SIGNING AND THE WORK ZONE, A SINGLE HEADED ARROW (M6-1) SHALL BE USED IN LIEU OF THE DOUBLE HEADED ARROW (M6-4).
- B. FOR A LANE CLOSURE ON A SIDE ROAD OR DRIVEWAY:
 

USE APPLICABLE PORTIONS OF THE TYPICAL APPLICATION OF TRAFFIC CONTROL DEVICES (STD. 701501, STD. 701606 OR THE APPROPRIATE STANDARD). THE SPACING OF SIGNS AND BARRICADES SHALL BE ADJUSTED FOR FIELD CONDITIONS AS DIRECTED BY THE ENGINEER. THE DIRECTIONAL ARROW SHALL BE COVERED OR REMOVED WHEN NO LONGER CONSISTENT WITH THE SIDE ROAD LANE CLOSURE.
- C. ADVANCE WARNING SIGNS ARE TO BE OMITTED ON DRIVEWAY UNLESS OTHERWISE NOTED.
- D. THE TRAFFIC CONTROL AND PROTECTION FOR SIDE ROADS, INTERSECTIONS, AND DRIVEWAYS SHALL BE INCIDENTAL TO THE COST OF SPECIFIED TRAFFIC CONTROL STANDARDS OR ITEMS.

All dimensions are in millimeters (inches) unless otherwise shown.

FILE NAME = W:\dststd\22x34\col8.dgn	USER NAME = goglienobt	DESIGNED - LHA	REVISED - J. OBERLE 10-18-95
		DRAWN -	REVISED - A. HOUSEH 03-06-96
		CHECKED -	REVISED - A. HOUSEH 10-15-96
		DATE - 06-89	REVISED - T. RAMMACHER 01-06-00

STATE OF ILLINOIS  
DEPARTMENT OF TRANSPORTATION

TRAFFIC CONTROL AND PROTECTION FOR SIDE ROADS, INTERSECTIONS, AND DRIVEWAYS			
SCALE: NONE	SHEET NO. 1 OF 1 SHEETS	STA.	TO STA.

F.A. RTE.	SECTION	COUNTY	TOTAL SHEETS	SHEET NO.
57	1919.28	COOK	119	106
TC-10			CONTRACT NO. 60371	
FED. ROAD DIST. NO. 1 ILLINOIS FED. AID PROJECT				

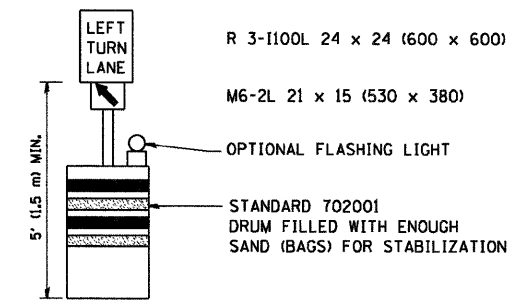
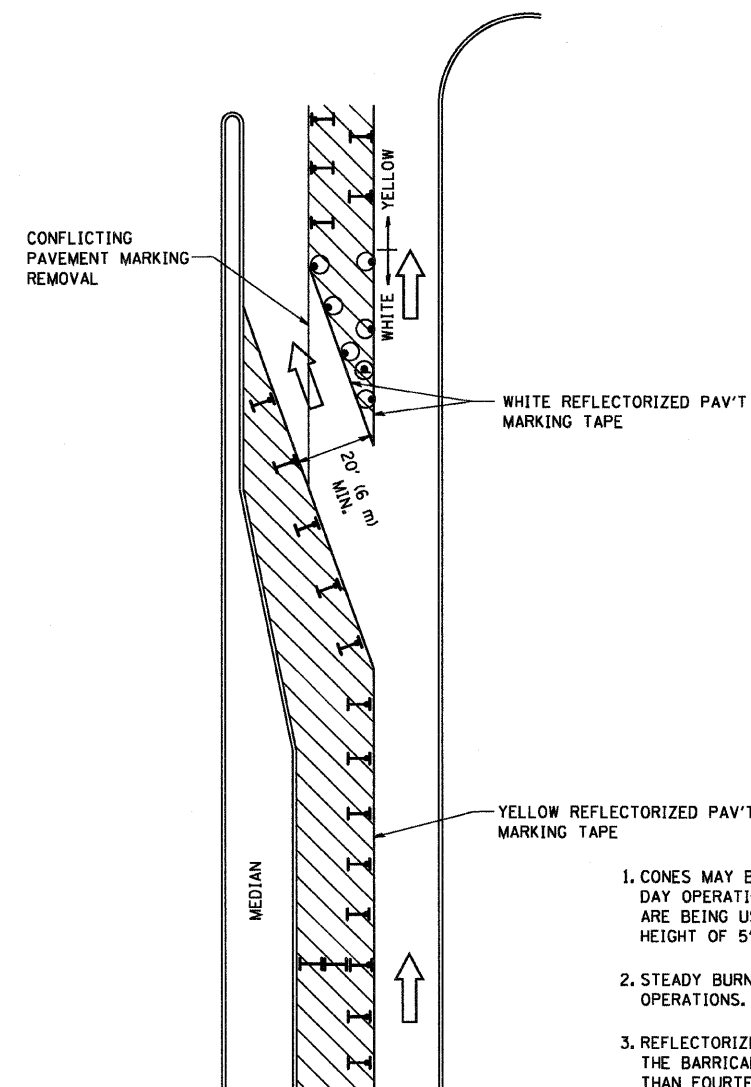





**GENERAL NOTES**

1. CONES MAY BE SUBSTITUTED FOR BARRICADES OR DRUMS AT HALF THE SPACING DURING DAY OPERATIONS. CONES SHALL BE A MINIMUM OF 28 (710) IN HEIGHT. WHEN CONES ARE BEING USED, THE "LEFT TURN LANE" SIGN MAY BE SKID MOUNTED AT A MINIMUM HEIGHT OF 5' (1.5 m).
2. STEADY BURNING LIGHTS WILL NOT BE REQUIRED ON BARRICADES OR DRUMS FOR DAY OPERATIONS. ALL LIGHTS SHALL BE MONODIRECTIONAL.
3. REFLECTORIZED TEMPORARY PAVEMENT MARKING TAPE SHALL BE PLACED THROUGHOUT THE BARRICADED AREA OF EACH TURN BAY WHERE THE CLOSURE TIME IS GREATER THAN FOURTEEN DAYS.
4. THIS APPLICATION ALSO APPLIES WHEN WORK IS BEING PERFORMED IN THE RIGHT LANE(S) AND THE RIGHT TURN BAY IS TO REMAIN OPEN. UNDER THIS CONDITION, "RIGHT TURN LANE" R3-100 24 x 24 (600 x 600) AND M6-2R 21 x 15 (530 x 380) SHALL BE USED.
5. THESE CONTROLS SHALL SUPPLEMENT MAINLINE TRAFFIC CONTROL FOR LANE CLOSURES.
6. LONGITUDINAL DIMENSIONS MAY BE ADJUSTED TO FIT FIELD CONDITIONS.
7. FORM BT 725 IS REQUIRED.
8. TRAFFIC CONTROL AND PROTECTION AT TURN BAYS (TO REMAIN OPEN TO TRAFFIC) SHALL BE INCLUDED IN THE COST SPECIFIED TRAFFIC CONTROL STANDARDS OR ITEMS.

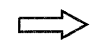
All dimensions are in inches (millimeters) unless otherwise shown.

**LEGEND**

-  WORK AREA
-  LANE OPEN TO TRAFFIC
-  TYPE I OR II BARRICADE WITH STEADY BURN LIGHT
-  DRUM WITH STEADY BURN LIGHT
-  DRUM WITH SIGN (WITH OPTIONAL FLASHING LIGHT) SEE DETAIL
-  TYPE I OR II CHECK BARRICADE WITH FLASHING LIGHT

FILE NAME = W:\dststd\22x34\to14.dgn	USER NAME = geglionobt	DESIGNED -	REVISED -T. RAMMACHER 09-08-94
		DRAWN -	REVISED - A. HOUSEH 11-07-95
		CHECKED -	REVISED - A. HOUSEH 10-12-96
		DATE -	REVISED -T. RAMMACHER 01-06-00

**STATE OF ILLINOIS  
DEPARTMENT OF TRANSPORTATION**

TRAFFIC CONTROL AND PROTECTION AT TURN BAYS (TO REMAIN OPEN TO TRAFFIC)			
SCALE: NONE	SHEET NO. 1 OF 1 SHEETS	STA.	TO STA.

F.A.I. RTE.	SECTION	COUNTY	TOTAL SHEETS	SHEET NO.
57	1919.28	COOK	119	107
TC-14			CONTRACT NO. 60371	
FED. ROAD DIST. NO. 1 ILLINOIS FED. AID PROJECT				

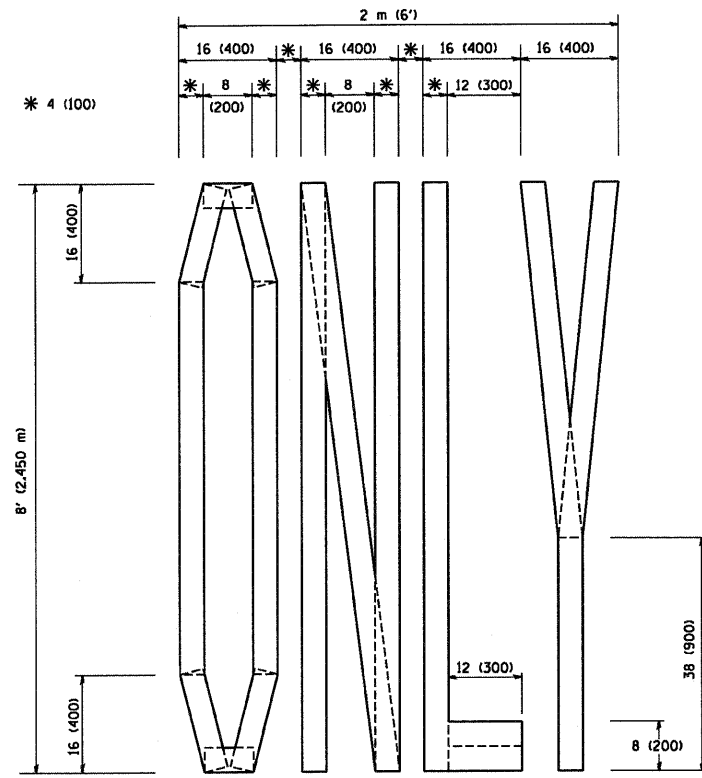

QUANTITY  
 4 (100) LINE = 64.1 ft. (19.7 m)  
 21.1 sq. ft. (1.97 sq. m)

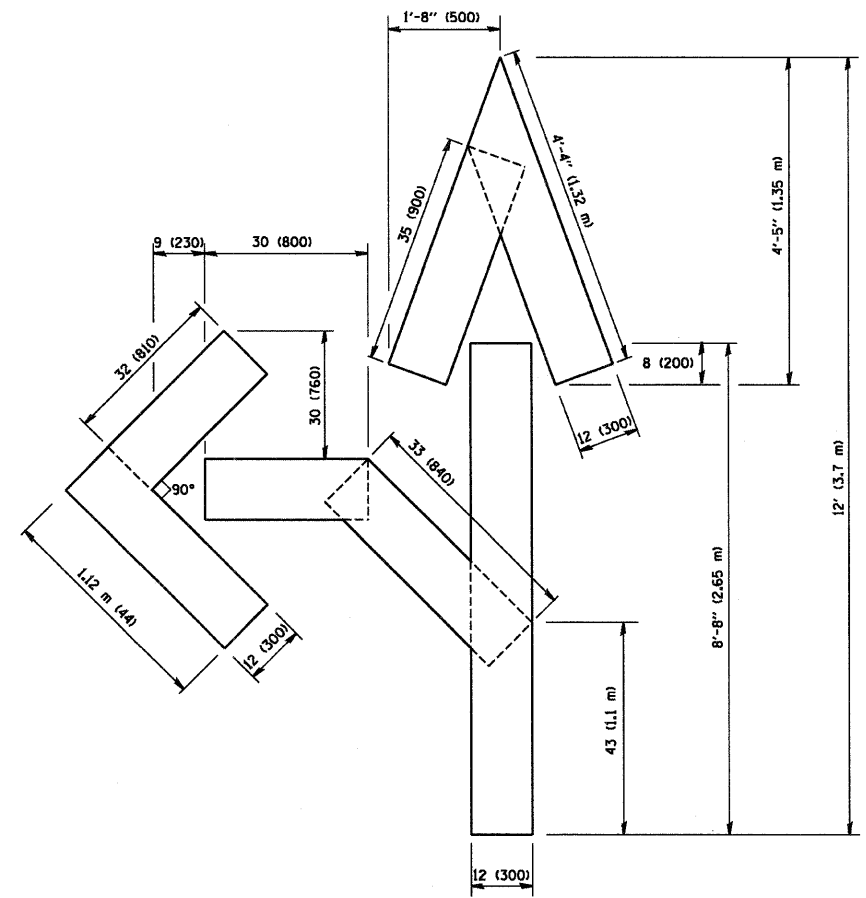

QUANTITY  
 4 (100) LINE = 82.5 ft. (25.3 m)  
 27.5 sq. ft. (2.53 sq. m)

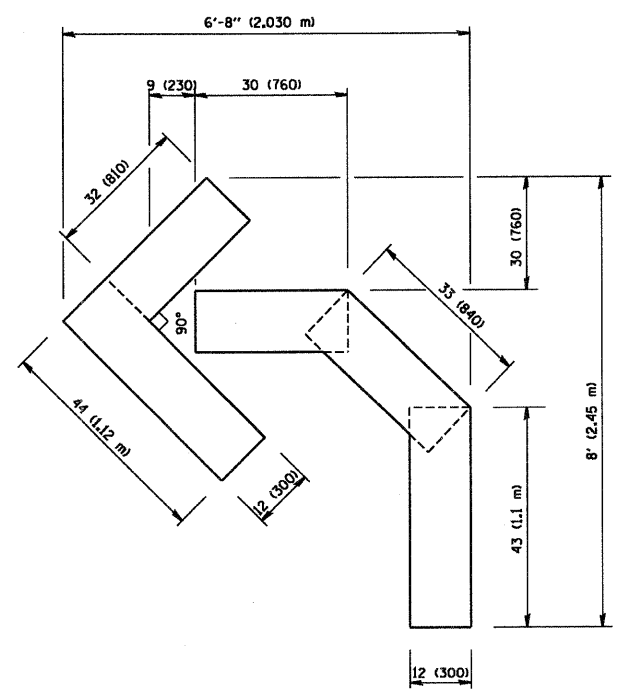

QUANTITY  
 4 (100) LINE = 45.5 ft. (13.9 m)  
 15.2 sq. ft. (1.39 sq. m)

All dimensions are in inches (millimeters) unless otherwise shown.

FILE NAME = W:\diststd\22x34\vol6.dgn	USER NAME = geglienobt	DESIGNED -	REVISED -T. RAMMACHER 06-05-96
		DRAWN -	REVISED -T. RAMMACHER 11-04-97
	PLOT SCALE = 50.0000' / IN.	CHECKED -	REVISED -T. RAMMACHER 03-02-98
	PLOT DATE = 1/4/2008	DATE - 09-18-94	REVISED -E. GOMEZ 08-28-00

STATE OF ILLINOIS  
 DEPARTMENT OF TRANSPORTATION

PAVEMENT MARKING LETTERS AND SYMBOLS FOR TRAFFIC STAGING			
SCALE: NONE	SHEET NO. 1	OF 1 SHEETS	STA. TO STA.

F.A.I. RTE.	SECTION	COUNTY	TOTAL SHEETS	SHEET NO.
57	1919.28	COOK	119	108
TC-16			CONTRACT NO. 60371	
FED. ROAD DIST. NO. 1 ILLINOIS FED. AID PROJECT				

**PARTIAL RAMP CLOSURE DETAILS**

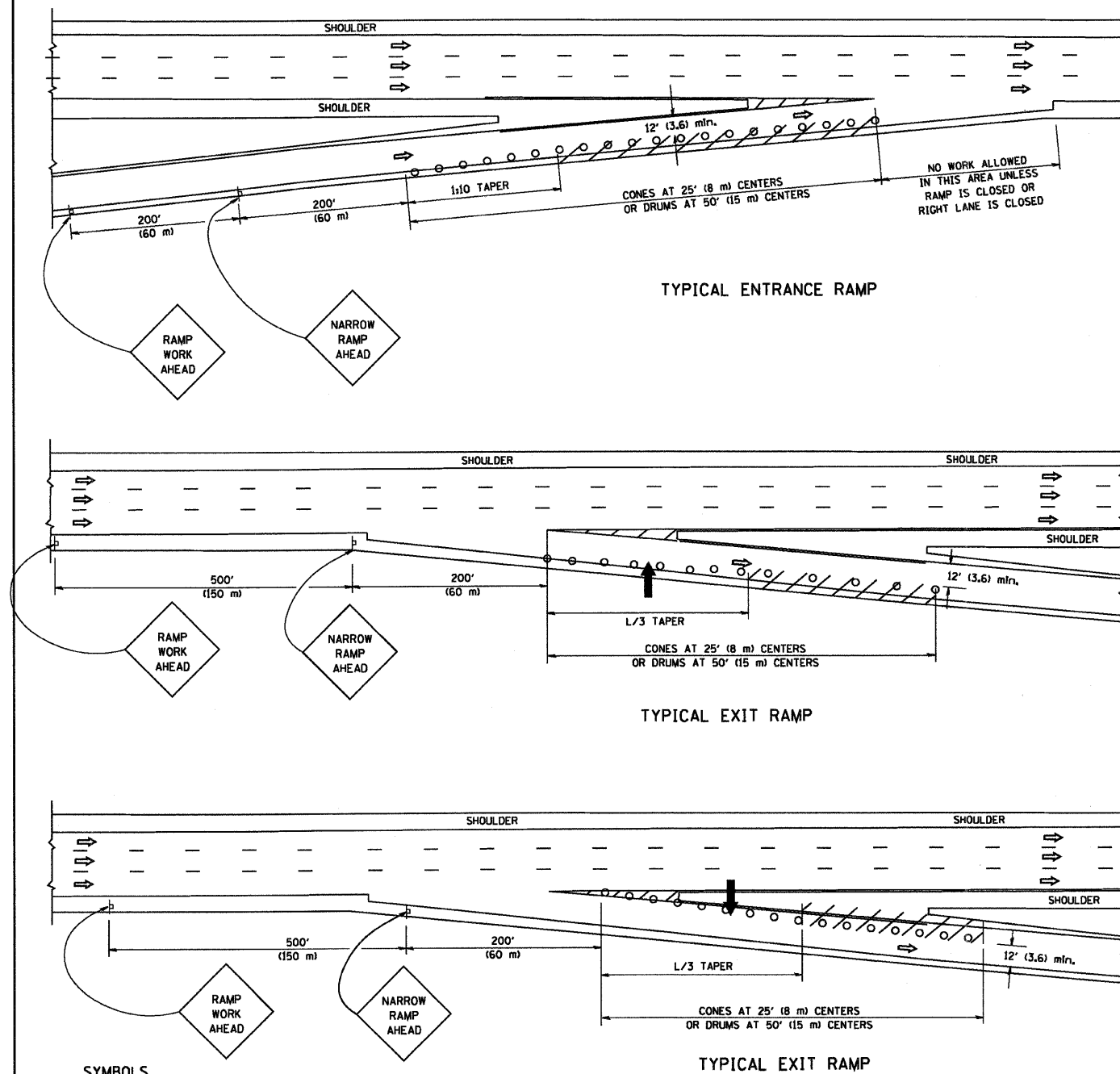

**SYMBOLS**

- ARROWBOARD
- WORK AREA
- SIGN ON PORTABLE OR PERMANENT SUPPORT
- FLAGGER WITH CONTROL SIGN
- TYPE II BARRICADE, DRUM OR VERTICAL BARRICADE WITH STEADY BURN MONO-DIRECTIONAL LIGHT
- CONE, DRUM OR BARRICADE

**GENERAL NOTES**

1. THE "L" DISTANCE EQUALS:
 

SPEED LIMIT	FORMULAS
45 mph (80 km/h) OR GREATER:	METRIC    ENGLISH
	$L = 0.65(W)(S)$ $L = (W)(S)$

W = WIDTH OF OFFSET IN FEET (METERS)  
S = NORMAL POSTED SPEED MPH (KM/H)
2. PLASTIC DRUMS WITH HIGH PERFORMANCE REFLECTIVE SHEETING AND STEADY BURNING LIGHTS ARE REQUIRED FOR ALL NIGHTTIME CLOSURES.
3. ALL SIGNS SHALL BE POST MOUNTED IF THE CLOSURE TIME EXCEEDS FOUR DAYS.
4. FLASHING LIGHTS SHALL BE USED DURING THE HOURS OF DARKNESS AND SHALL BE INSTALLED ABOVE THE FIRST TWO SETS OF SIGNS.

**SHOULDER CLOSURE DETAILS**

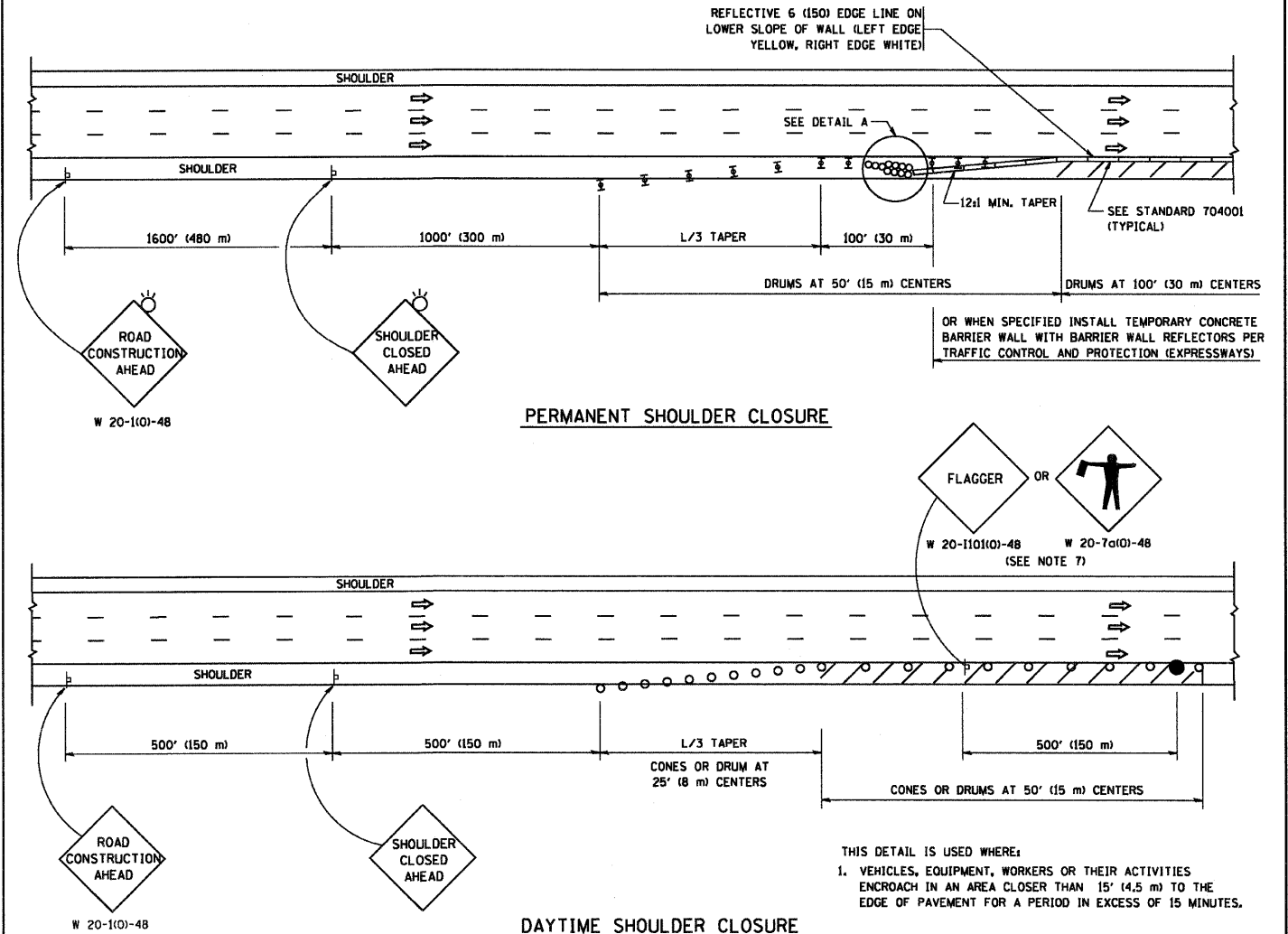

THIS DETAIL IS USED WHERE:  
1. VEHICLES, EQUIPMENT, WORKERS OR THEIR ACTIVITIES ENCR OACH IN AN AREA CLOSER THAN 15' (4.5 m) TO THE EDGE OF PAVEMENT FOR A PERIOD IN EXCESS OF 15 MINUTES.

ARRAY DESIGN PER MANUFACTURER TO BE NCHRP 350 COMPLIANT FOR POSTED SPEED.

**DETAIL "A"**  
IMPACT ATTENUATOR, TEMPORARY  
(SEE NOTE 5)

ALL DIMENSIONS ARE IN INCHES (MILLIMETERS) UNLESS OTHERWISE SHOWN.

FILE NAME =  
W:\dotstsd\22x34\1a17.dgn

USER NAME = geglionobt  
DRAWN - D.W.S.  
PLOT SCALE = 50.0000' / IN.  
PLOT DATE = 1/4/2008

DESIGNED -  
CHECKED - J.A.F. 12-06  
DATE - 11-96

REVISED - J.A.F. 12-02  
REVISED - 04-03  
REVISED - J.A.F. 12-06  
REVISED - S.P.B. 01-07

**STATE OF ILLINOIS**  
**DEPARTMENT OF TRANSPORTATION**

**TRAFFIC CONTROL DETAILS FOR FREEWAY**  
**SHOULDER CLOSURES AND PARTIAL RAMP CLOSURES**

SCALE: NONE    SHEET NO. 1 OF 1 SHEETS    STA. TO STA.

F.A.L. RTE.	SECTION	COUNTY	TOTAL SHEETS	SHEET NO.
57	1919.28	COOK	119	109
TC-17			CONTRACT NO. 60371	
FED. ROAD DIST. NO. 1 (ILLINOIS) FED. AID PROJECT				



WITH INTERSECTION TRAFFIC SIGNALS

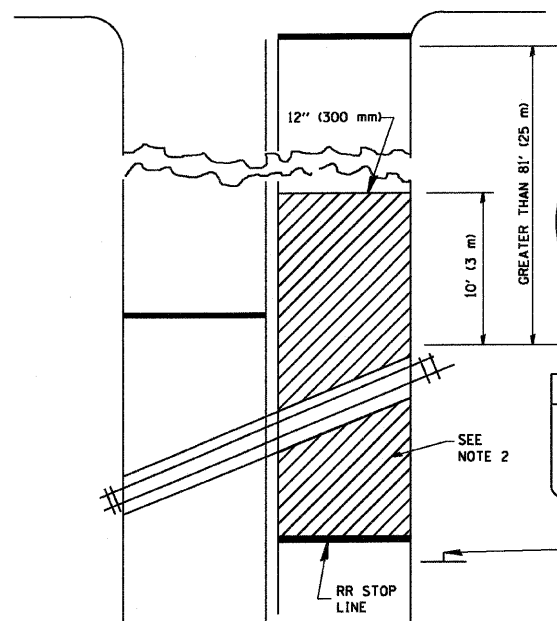

WITH NEAR-SIDE TRAFFIC SIGNALS

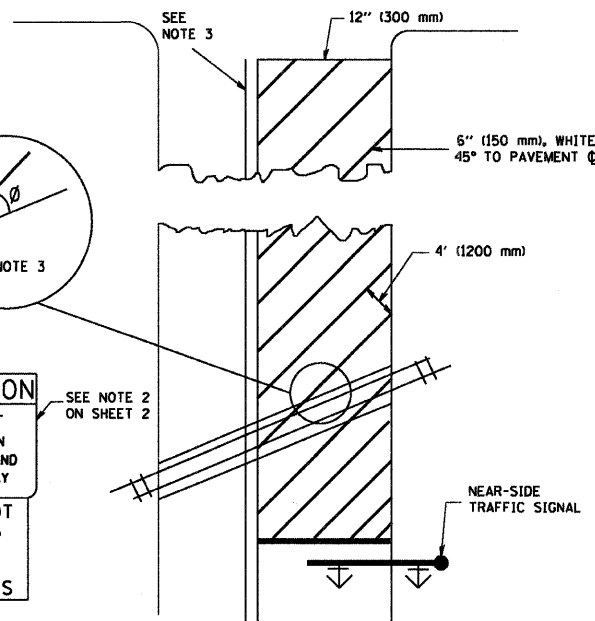

WITH NONSIGNALIZED INTERSECTION

81' (25 m) OR LESS TO CLOSEST RAIL

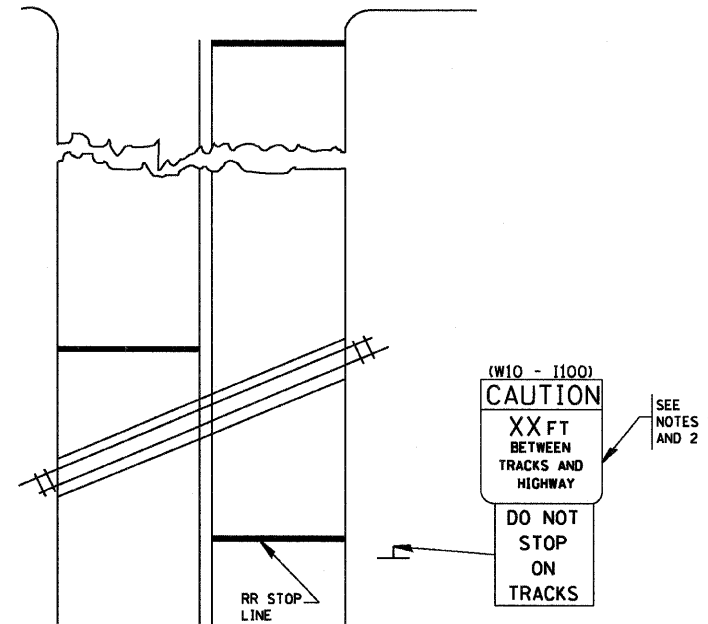

CAUTION  
XX FT  
BETWEEN  
TRACKS AND  
HIGHWAY  
DO NOT  
STOP  
ON  
TRACKS

(W10 - 1100)  
CAUTION  
XX FT  
BETWEEN  
TRACKS AND  
HIGHWAY  
DO NOT  
STOP  
ON  
TRACKS

- NOTES:
1. PAVEMENT MARKINGS TO BE INSTALLED ONLY ON APPROACHES TO INTERSECTIONS CONTROLLED BY TRAFFIC SIGNALS WHICH ARE INTERCONNECTED WITH THE RAILROAD WARNING SIGNALS.
  2. WHERE NEAR-SIDE TRAFFIC SIGNALS ARE USED, THE PAVEMENT MARKINGS EXTENDS TO THE INTERSECTION.
  3. WHERE THE ANGLE BETWEEN THE DIAGONAL STRIPES AND THE TRACK (θ) WOULD BE LESS THAN APPROXIMATELY 20°, THE STRIPES SHOULD BE SLOPED IN THE OPPOSITE DIRECTION FROM THAT SHOWN.

- NOTE:
1. DISTANCE TO BE SHOWN ON SIGN MEASURED FROM A POINT 6 FEET (1.8 m) FROM THE RAIL CLOSEST TO THE INTERSECTION TO THE STOP LINE OR CROSSWALK, WHICHEVER IS CLOSEST, ROUNDED DOWN TO THE NEAREST 5 FEET (1.5 m), WHERE THERE IS NO STOP LINE, MEASURE TO POINT WHERE THE DRIVER HAS A VIEW OF APPROACHING TRAFFIC.
  2. THE CLEARANCE SIGN IS ALSO TO BE USED AS AN INTERIM MEASURE AT LOCATIONS WITH INTERCONNECTED INTERSECTION TRAFFIC SIGNALS WHERE IT IS PLANNED TO CHANGE THEM TO NEAR-SIDE SIGNALS AT A FUTURE TIME. IN THIS CASE, THE DISTANCE TO BE SHOWN ON THE SIGN IS MEASURED FROM THE EDGE OF THE STRIPED-OUT AREA INSTEAD OF 6-FEET FROM THE RAIL. THE SIGN IS TO BE REMOVED WHEN THE NEAR-SIDE SIGNALS ARE INSTALLED AND THE PAVEMENT MARKINGS EXTEND TO THE INTERSECTION.

ALL DIMENSIONS ARE IN INCHES (MILLIMETERS) UNLESS OTHERWISE SHOWN.

FILE NAME = W:\disto\22x34\to23.dgn	USER NAME = geglcnobt	DESIGNED -	REVISED - 01-01-07
		DRAWN -	REVISED -
		CHECKED -	REVISED -
		DATE -	REVISED -

STATE OF ILLINOIS  
DEPARTMENT OF TRANSPORTATION

TYPICAL SUPPLEMENTAL SIGNING AND PAVEMENT MARKING TREATMENT FOR RAILROAD CROSSINGS			
SCALE: NONE	SHEET NO. 1 OF 1 SHEETS	STA.	TO STA.

F.A.R.T.E.	SECTION	COUNTY	TOTAL SHEETS	SHEET NO.
57	1919.28	COOK	119	111
TC-23			CONTRACT NO. 60371	
FED. ROAD DIST. NO. 1 ILLINOIS FED. AID PROJECT				

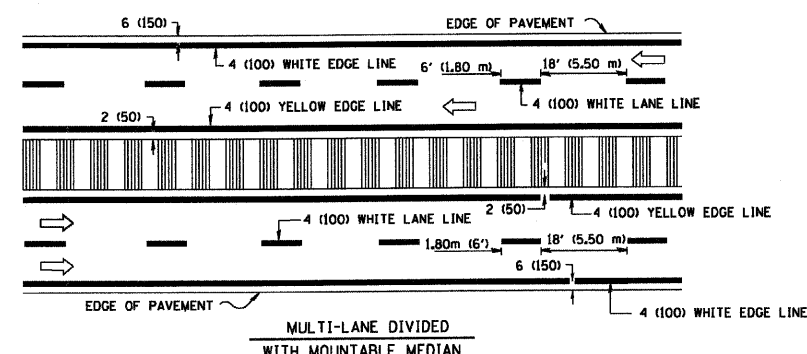
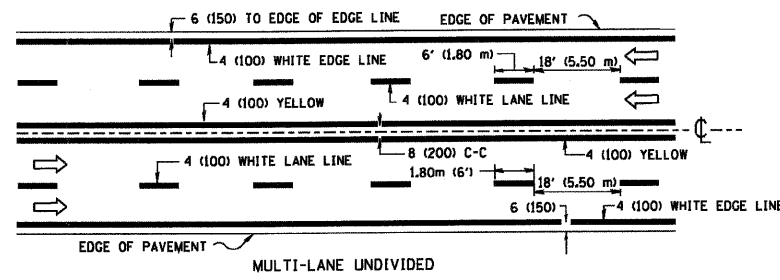
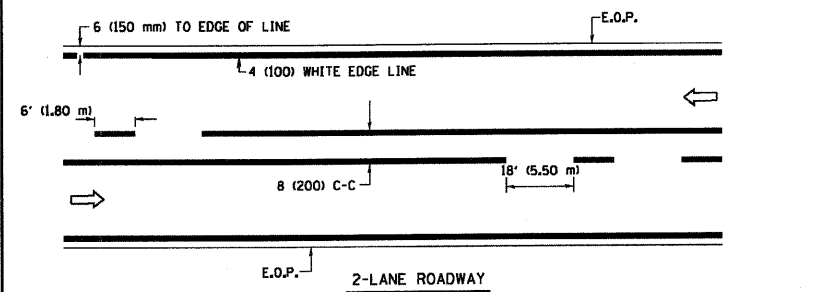

NOTE: MEDIANS WITH BARRIER CURB DO NOT REQUIRE AN EDGE LINE

TYPICAL LANE AND EDGE LINE MARKING

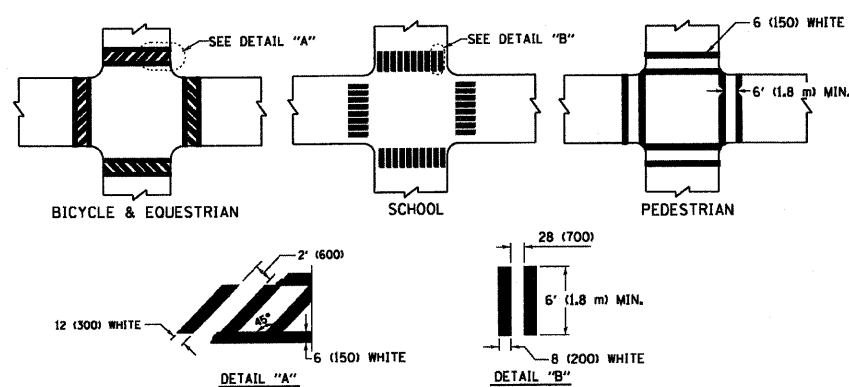

TYPICAL CROSSWALK MARKING

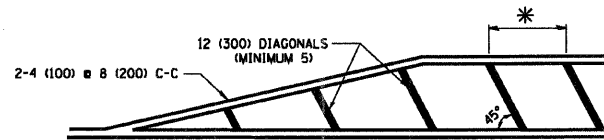

\* FOR MEDIAN LENGTHS WHERE DIAGONAL SPACING CANNOT BE ATTAINED, USE 5 (FIVE) EQUALLY SPACED DIAGONAL LINES.  
\* DIAGONAL LINE SPACING: 20' (6.1 m) C-C

PAINTED MEDIANS

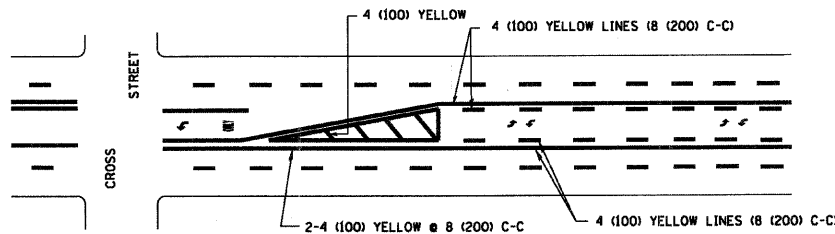

A MINIMUM OF TWO PAIRS OF TURN ARROWS SHALL BE USED, WHITE IN COLOR. ADDITIONAL PAIRS SHALL BE PLACED AT 200' (60 m) TO 300' (90 m) INTERVALS.

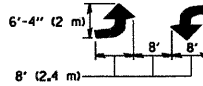

MEDIAN WITH TWO-WAY LEFT TURN LANE

TYPICAL PAINTED MEDIAN MARKING

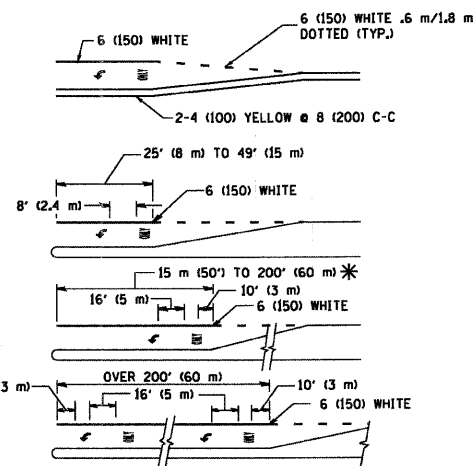

FULL SIZE LETTERS 8' (2.4 m) AND ARROWS SHALL BE USED.  
AREA = 15.8 SQ. FT. (1.47 m<sup>2</sup>) AREA = 22.9 SQ. FT. (2.13 m<sup>2</sup>)  
\* TURN LANES IN EXCESS OF 400' (120 m) IN LENGTH MAY HAVE AN ADDITIONAL SET OF ARROW - "ONLY" INSTALLED MIDWAY BETWEEN THE OTHER TWO SETS OF ARROW - "ONLY".

TYPICAL LEFT (OR RIGHT) TURN LANE

TYPICAL TURN LANE MARKING

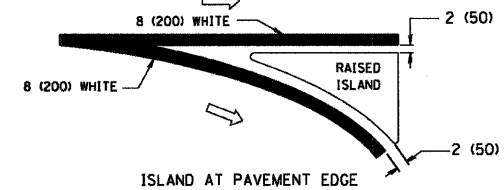
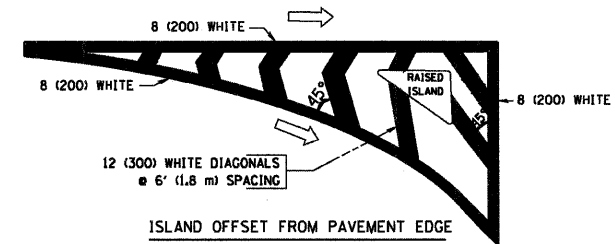

TYPICAL ISLAND MARKING

TYPE OF MARKING	WIDTH OF LINE	PATTERN	COLOR	SPACING / REMARKS
CENTERLINE ON 2 LANE PAVEMENT	4 (100)	SKIP-DASH	YELLOW	6' (1.80 m) LINE WITH 18' (5.50 m) SPACE
CENTERLINE ON MULTI-LANE UNDIVIDED PAVEMENT	2 @ 4 (100)	SOLID	YELLOW	8 (200) C-C
NO PASSING ZONE LINES FOR ONE DIRECTION FOR BOTH DIRECTIONS	4 (100) 2 @ 4 (100)	SOLID SOLID	YELLOW YELLOW	8 (200) C-C
LANE LINES	4 (100) 5 (125) ON FREEWAYS	SKIP-DASH SKIP-DASH	WHITE WHITE	6' (1.80 m) LINE WITH 18' (5.50 m) SPACE
DOTTED LINES (EXTENSIONS OF CENTER, LANE OR TURN LANE MARKINGS)	SAME AS LINE BEING EXTENDED	SKIP-DASH	SAME AS LINE BEING EXTENDED	2' (600) LINE WITH 6' (1.8) SPACE
EDGE LINES	4 (100)	SOLID	YELLOW-LEFT WHITE-RIGHT	OUTLINE MOUNTABLE MEDIANS IN YELLOW; EDGE LINES ARE NOT USED NEXT TO BARRIER CURB
TURN LANE MARKINGS	6 (150) LINES, FULL SIZE LETTERS & SYMBOLS (8' (2.4 m))	SOLID	WHITE	SEE TYPICAL TURN LANE MARKING DETAIL
TWO WAY LEFT TURN MARKING	2 @ 4 (100) EACH DIRECTION 8' (2.4 m) LEFT ARROW	SKIP-DASH AND SOLID IN PAIRS	YELLOW WHITE	6' (1.8 m) LINE WITH 18' (5.50 m) SPACE FOR SKIP-DASH; 8 (200) C-C BETWEEN SOLID LINE AND SKIP-DASH LINE SEE TYPICAL TWO-WAY LEFT TURN MARKING DETAIL
CROSSWALK LINES (PEDESTRIAN) A. DIAGONALS (BIKE & EQUESTRIAN) B. LONGITUDINAL BARS (SCHOOL)	2 @ 6 (150) 12 (300) @ 45° 8 (200) @ 90°	SOLID SOLID SOLID	WHITE WHITE WHITE	NOT LESS THAN 6' (1.8 m) APART 2' (600) APART 2'-4" (700) APART SEE TYPICAL CROSSWALK MARKING DETAILS.
STOP LINES	24 (600)	SOLID	WHITE	PLACE 4' (1.2 m) IN ADVANCE OF AND PARALLEL TO CROSSWALK, IF PRESENT. OTHERWISE, PLACE AT DESIRED STOPPING POINT. PARALLEL TO CROSSROAD CENTERLINE, WHERE POSSIBLE
PAINTED MEDIANS	2 @ 4 (100) WITH 12 (300) DIAGONALS @ 45°	SOLID	YELLOW; WHITE; ONE WAY TRAFFIC	8 (200) C-C FOR THE DOUBLE LINE SEE TYPICAL PAINTED MEDIAN MARKING.
GORE MARKING AND CHANNELIZING LINES	8 (200) WITH 12 (300) DIAGONALS @ 45°	SOLID	WHITE	DIAGONALS; 20' (6.1 m) (LESS THAN 30 MPH (50 km/h))
RAILROAD CROSSING	24 (600) TRANSVERSE LINES; "RR" IS 6' (1.8 m) LETTERS; 16 (400) LINE FOR "X"	SOLID	WHITE	SEE STATE STANDARD 780001 AREA OF: "R"=3.6 SQ. FT. (0.33m <sup>2</sup> ) EACH "X"=54.0 SQ. FT. (5.0 m <sup>2</sup> )

FOR FURTHER DETAILS ON PAVEMENT MARKING REFER TO STREET MARKING STANDARDS, PRINTED BY CITY OF CHICAGO, DEPARTMENT OF TRANSPORTATION, BUREAU OF TRAFFIC.

ALL DIMENSIONS ARE IN INCHES (MILLIMETERS) UNLESS OTHERWISE SHOWN.

FILE NAME = W:\dsc\std\22x34\to24.dgn	USER NAME = geglenobt	DESIGNED -	REVISED - T. RAMMACHER 12-07-00
		DRAWN -	REVISED -
	PLOT SCALE = 50.000 / IN.	CHECKED -	REVISED -
	PLOT DATE = 1/4/2008	DATE -	REVISED -

STATE OF ILLINOIS  
DEPARTMENT OF TRANSPORTATION

CITY OF CHICAGO			
TYPICAL PAVEMENT MARKINGS			
SCALE: NONE	SHEET NO. 1 OF 2 SHEETS	STA.	TO STA.

F.A. RTE.	SECTION	COUNTY	TOTAL SHEETS	SHEET NO.
57	1919.28	COOK	119	112
TC-24			CONTRACT NO. 60371	
FED. ROAD DIST. NO. 1 ILLINOIS FED. AID PROJECT				



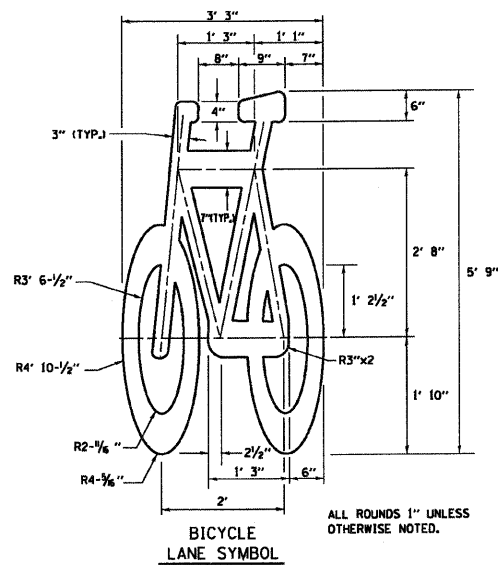
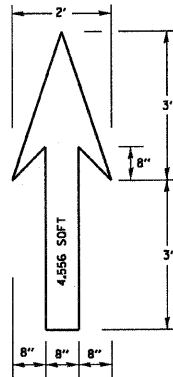

**NOTE:**  
 1.) FOR BIKE LANE SYMBOLS ONLY, USE PRE-FORMED THERMOPLASTIC WITH A MINIMUM THICKNESS OF 90 MILS, MINIMUM SKID RESISTANCE VALUE OF 60 BPN, & A MINIMUM INDEX OF REFRACTION OF 1.50.  
 2.) THE RESIDENT ENGINEER SHALL CONTACT MR. BEN GOMBERG AT 312-744-8093 AT LEAST ONE CALENDAR WEEK PRIOR TO INSTALLING BIKE LANE SYMBOLS.

**TYPICAL BIKE LANE SYMBOLS**  
 DRAWING #28

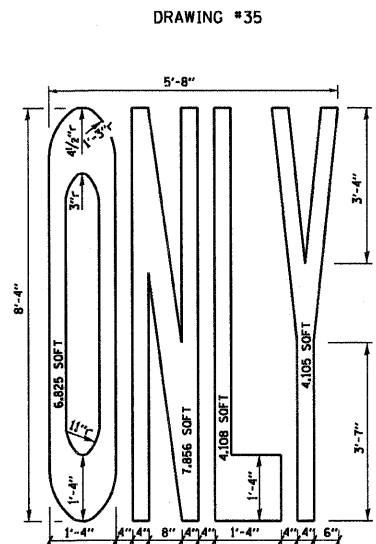
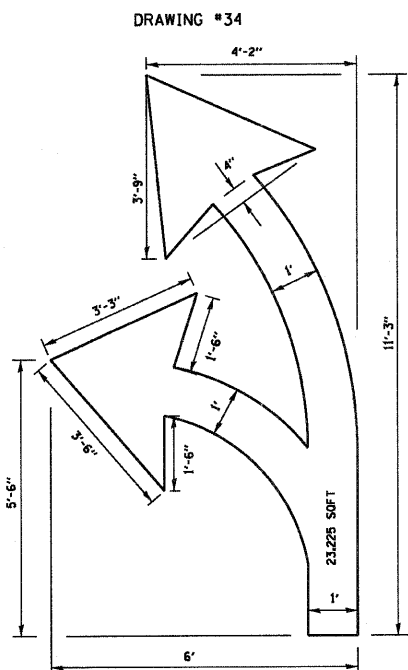
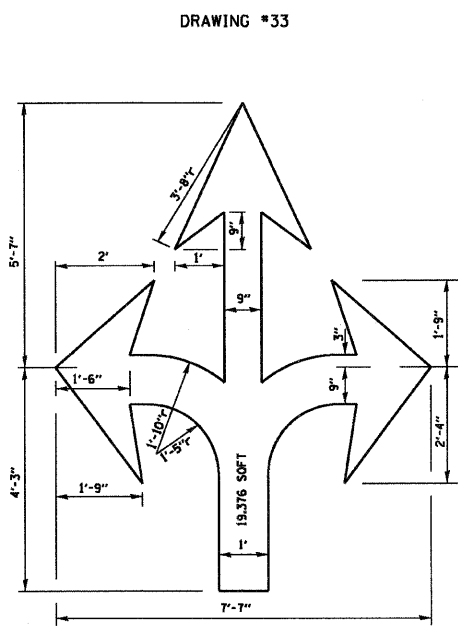
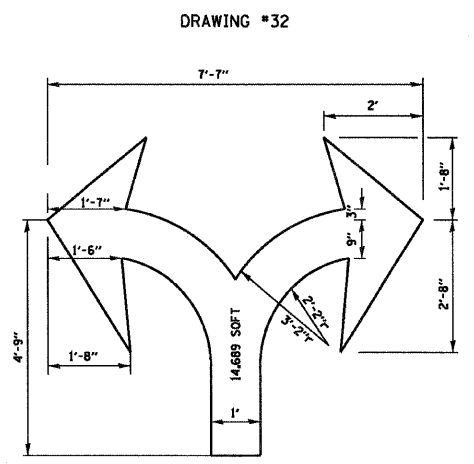
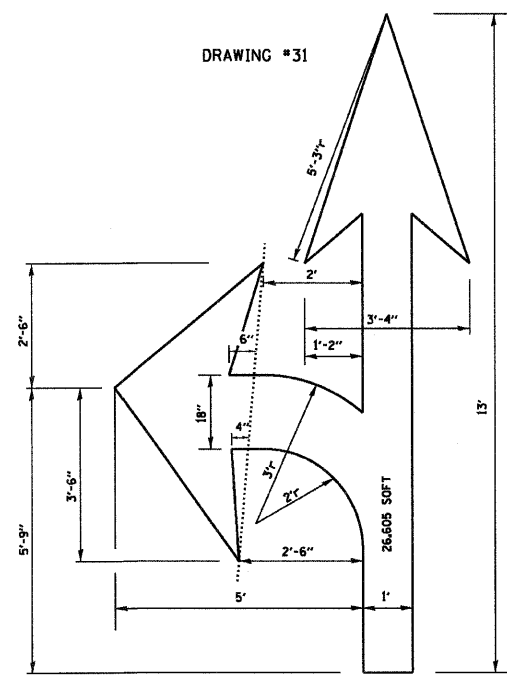
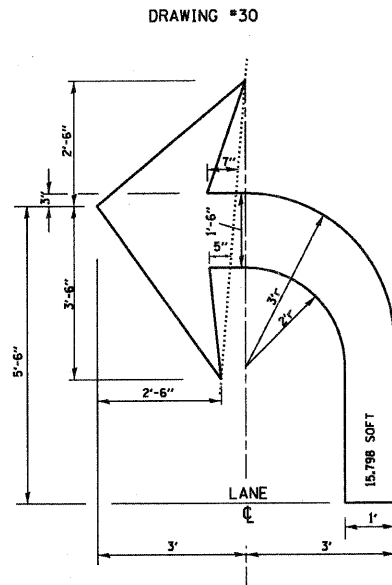
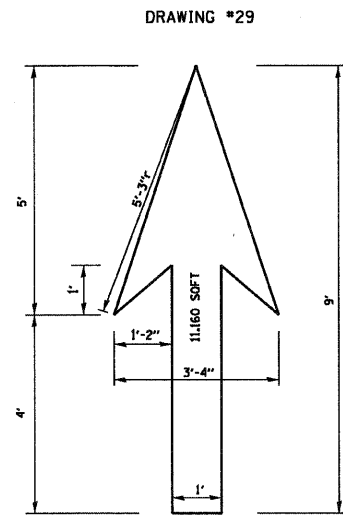

**NOTE:**  
 ALL MARKINGS SHALL BE SOLID WHITE UNLESS OTHERWISE NOTED IN THE PLANS

FILE NAME = W:\distatd\22\34\to24.dgn	USER NAME = geglienobt	DESIGNED -	REVISED - T. RAMMACHER 12-07-00
		DRAWN -	REVISED -
PLOT SCALE = 50.000 / IN.		CHECKED -	REVISED -
PLOT DATE = 1/4/2008		DATE -	REVISED -

**STATE OF ILLINOIS**  
**DEPARTMENT OF TRANSPORTATION**

<b>CITY OF CHICAGO</b>			
<b>TYPICAL PAVEMENT MARKINGS</b>			
SCALE: NONE	SHEET NO. 2 OF 2 SHEETS	STA.	TO STA.

F.A. RTE.	SECTION	COUNTY	TOTAL SHEETS	SHEET NO.
57	1919.28	COOK	119	113
TC-24		CONTRACT NO. 60371		
FED. ROAD DIST. NO. 1 ILLINOIS FED. AID PROJECT				

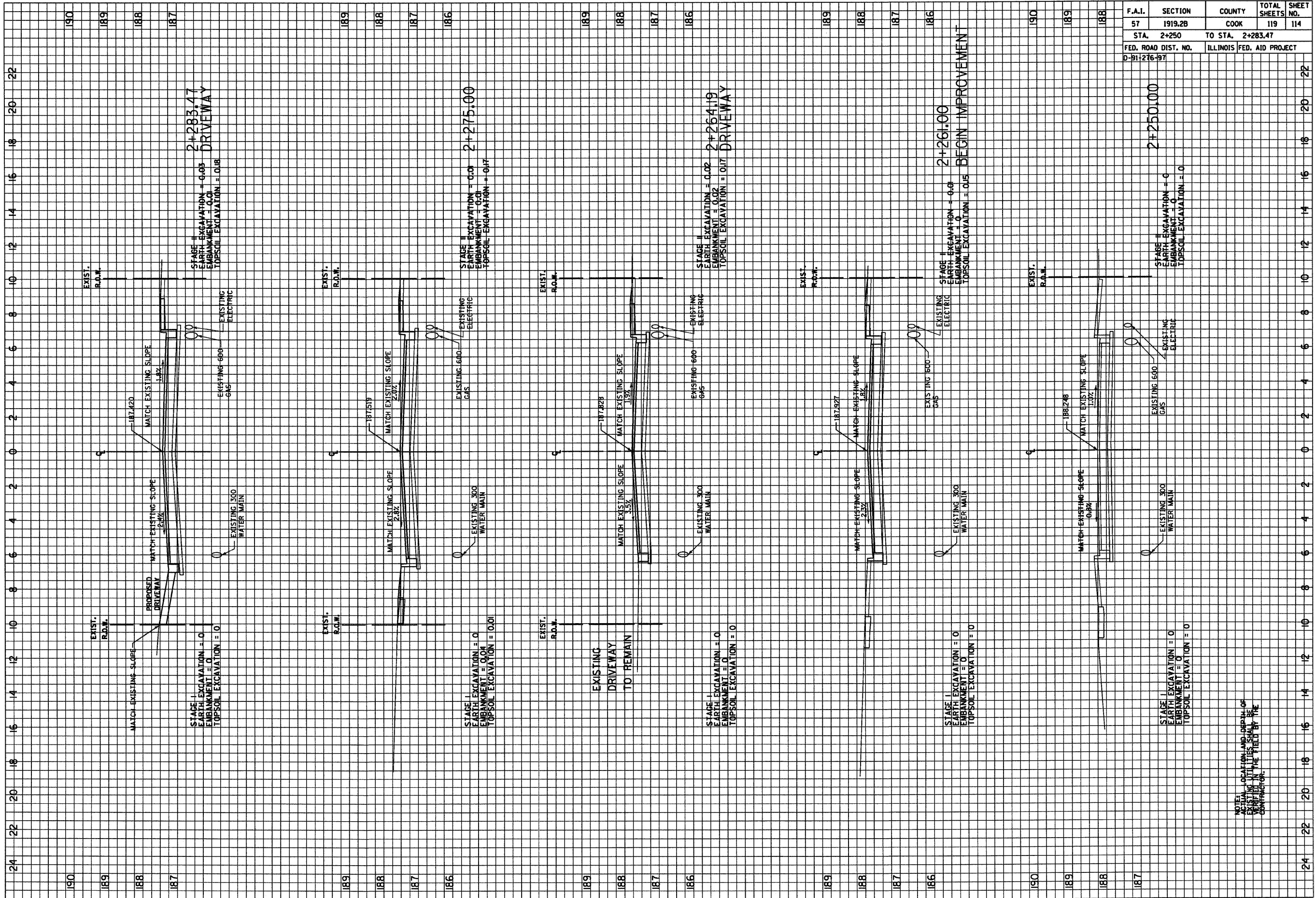

F.A.I.	SECTION	COUNTY	TOTAL SHEETS	SHEET NO.
57	1919.28	COOK	119	114
STA. 2+250		TO STA. 2+283.47		
FED. ROAD DIST. NO.		ILLINOIS FED. AID PROJECT		
D-91-276-97				

NOTE: LOCATION AND DEPTH OF EXISTING UTILITIES SHALL BE VERIFIED IN THE FIELD BY THE CONTRACTOR.

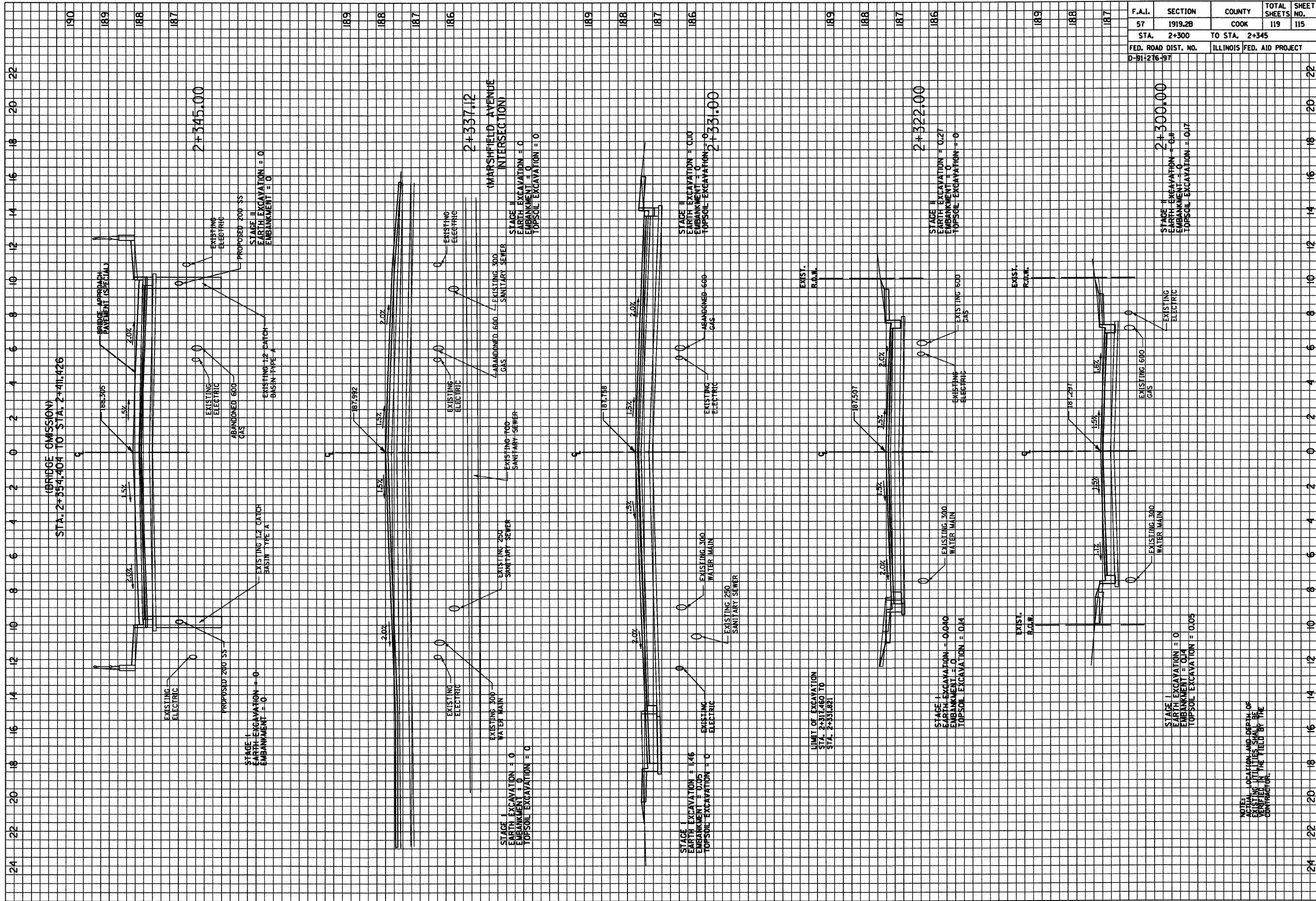

F.A.I.	SECTION	COUNTY	TOTAL SHEETS	SHEET NO.
57	1919.28	COOK	119	115
STA. 2+300		TO STA. 2+345		
FED. ROAD DIST. NO.		ILLINOIS FED. AID PROJECT		
D-91-276-97				

NOTE: LOCATION AND DEPTH OF EXISTING UTILITIES SHALL BE VERIFIED IN THE FIELD BY THE CONTRACTOR.

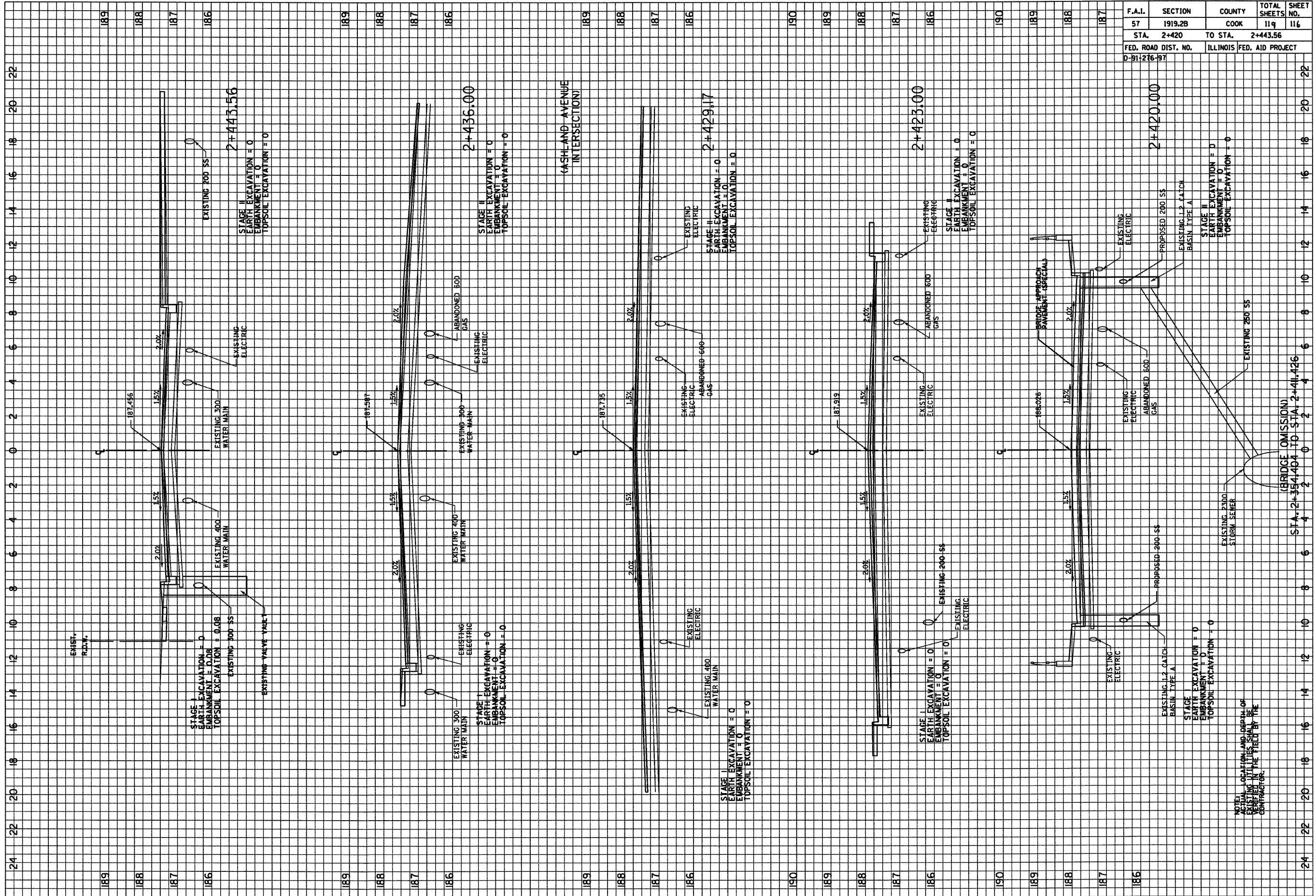

F.A.I.	SECTION	COUNTY	TOTAL SHEETS	SHEET NO.
57	1919.28	COOK	119	116
STA. 2+420		TO STA. 2+443.56		
FED. ROAD DIST. NO.		ILLINOIS FED. AID PROJECT		
D-91-276-97				

NOTE: LOCATION AND DEPTH OF EXISTING UTILITIES SHALL BE VERIFIED IN THE FIELD BY THE CONTRACTOR.

115th STREET OVER I-57

SCALE: HORZ. - 1:100  
VERT. - 1:50

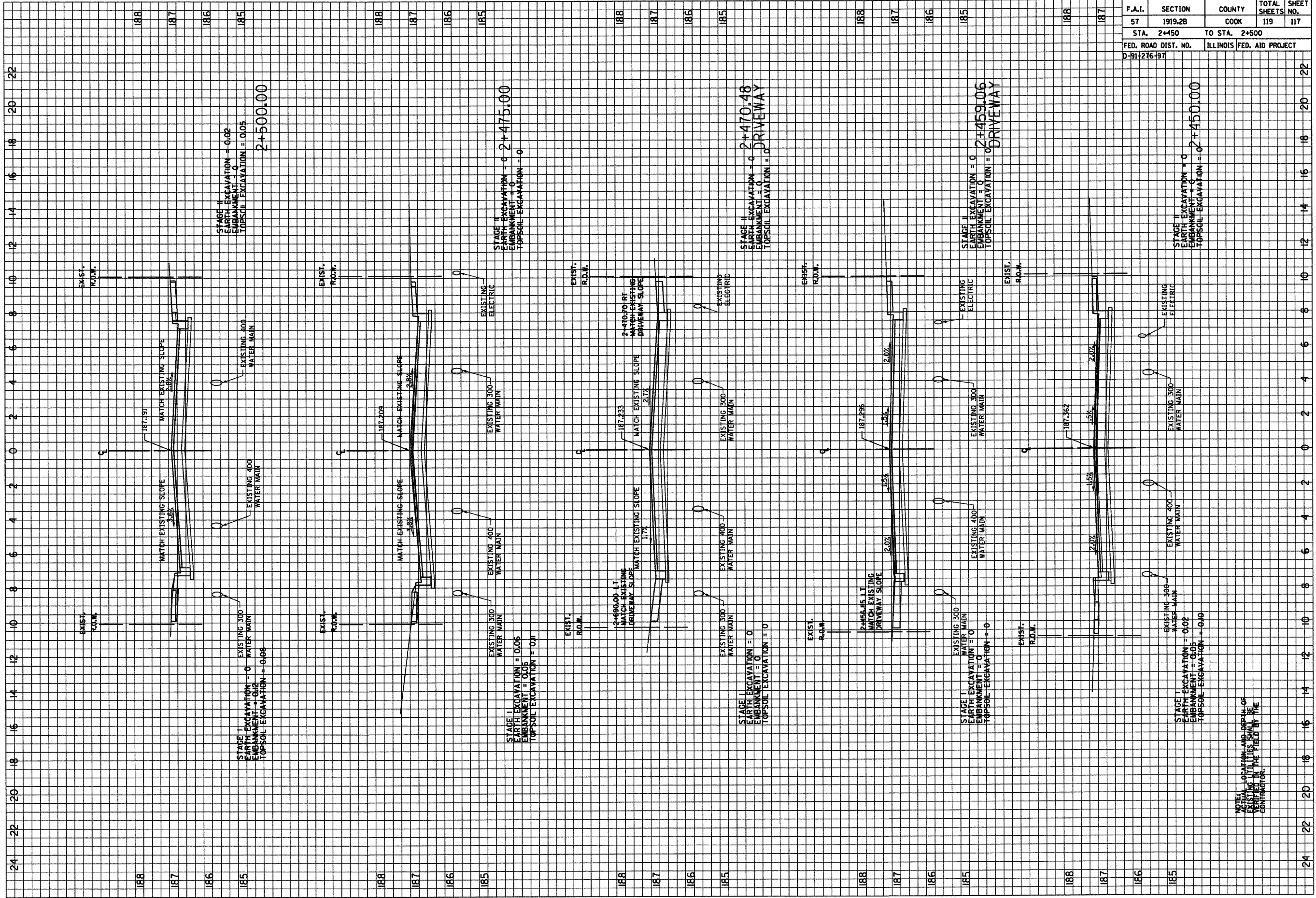

F.A.I.	SECTION	COUNTY	TOTAL SHEETS	SHEET NO.
57	1919.28	COOK	119	117
STA. 2+450		TO STA. 2+500		
FED. ROAD DIST. NO.		ILLINOIS	FED. AID PROJECT	
D-91-276-97				

NOTE: LOCATION AND DEPTH OF EXISTING UTILITIES SHALL BE DETERMINED IN THE FIELD BY THE CONTRACTOR.



F.A.I.	SECTION	COUNTY	TOTAL SHEETS	SHEET NO.
57	1919.2B	COOK	119	118
STA. 2+519		TO STA.		
FED. ROAD DIST. NO.		ILLINOIS	FED. AID PROJECT	
D-91-276-97				

2+519.40  
END OF IMPROVEMENT

EXIST. ROW

G

EXIST. ROW

NOTE: LOCATION AND DEPTH OF EXISTING UTILITIES SHALL BE VERIFIED IN THE FIELD BY THE CONTRACTOR.

F.A.L.	SECTION	COUNTY	TOTAL SHEETS	SHEET NO.
57	1919.2B	COOK	119	119
FED. ROAD DIST. NO.		ILLINOIS	FED. AID PROJECT	

THIS SHEET INTENTIONALLY LEFT BLANK

**COLLINS ENGINEERS**  
 123 North Wacker Drive  
 Suite 300  
 Chicago, IL 60606  
 (312) 704-9200  
 www.collinsengr.com  
 ILLINOIS PROFESSIONAL DESIGN FIRM LICENSE NO. 184-000993

REVISIONS	
NAME	DATE

ILLINOIS DEPARTMENT OF TRANSPORTATION

DATE: JANUARY 16, 2009

DRAWN BY: PRH  
 CHECKED BY: JMH