

F.A.I. RTE.	SECTION	COUNTY	TOTAL SHEETS	SHEET NO.
90	1213B-1	COOK	94	34
STA.		TO STA.		
FED. ROAD DIST. NO. 1		ILLINOIS FED. AID PROJECT		
CONTRACT NO. 60640				

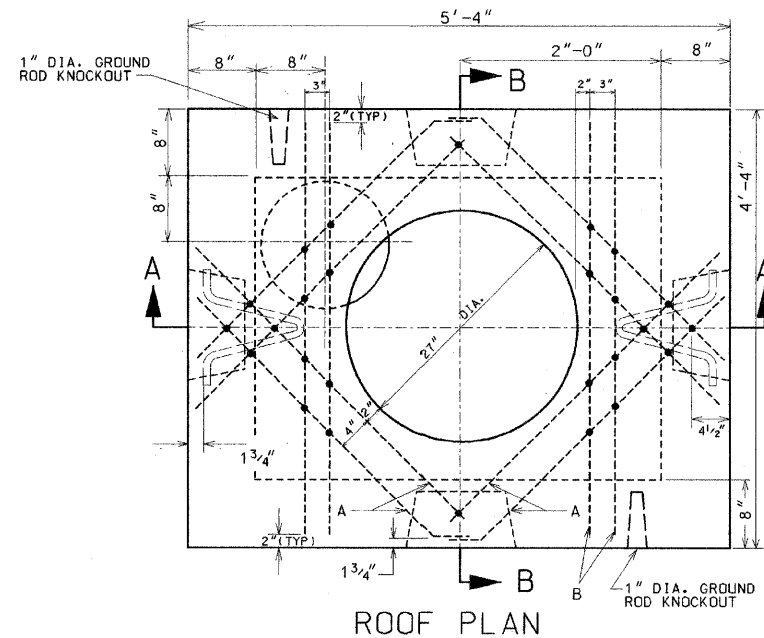

EXCAVATION (CONSTRUCTION INFORMATION)	
COMPLETE MANHOLE	6.0 CU. YDS.
NEW ROOF ONLY	2.0 CU. YDS
SHEETING MANHOLE	150.0 SQ. FT.

#5 REINFORCING BARS			
BAR	LENGTH	NO. OF RODS	TOTAL FT.
A	3'-4"	4	13'-4"
B	4'-0"	10	40'-0"

MATERIALS FOR ROOF ONLY	
CONCRETE	0.45 CU. YDS.
REINFORCING BARS #5	54'

DRG.	MATERIAL	CODE	SIZE	No. Req.
	FORM FOR MANHOLE	17-6674-6000 17-6648-5320	3x4x4	1
	CONDUIT END BELL		AS REQ.	
	TILE, SEWER	39-4038-3200	12"/24"	1
	SLAB BOLSTER		2"	20'
	BAR, REINFORCING	20-5472-9650	5/8" ø	54'
	TIE WIRE	13-9938-6106	#20GA.	35'
7878	PULLING IRON	02-4483-6970	3/4" ø	2
	CONCRETE	05-3267-2940	3 CU. YDS	
	SEWER BRICK	05-1452-9720	STD.	50
10792	GRATE FOR SUMP	02-4368-7100	15" ø	1
	GROUND ROD	09-7796-9200	3/4"x10'	1
	GROUND ROD CLAMP	09-2636-3240	3/4"	1
	CRUSHED STONE	05-9057-5471	3/4" TWO BAGS	
872	MANHOLE FRAME	02-4299-5524	24"	1
872	MANHOLE COVER	02-4574-5040	24"	1
	CONC. CHANNEL INSERT	02-4574-5040	3'	8

- NOTES:
1. PRECAST MANHOLES MUST BE PROVIDED WITH CHANNEL INSERTS, PULLING IRONS, AND CONDUIT KNOCK-OUTS.
 2. ALL CONCRETE MUST BE PORTLAND CEMENT CONCRETE MEETING IDOT REQUIREMENTS FOR CLASS PC CONCRETE FOR PRE-CAST STRUCTURES, OR CLASS S1 CONCRETE FOR CAST-IN-PLACE STRUCTURES.
 3. REINFORCING BARS MUST MEET ASTM A615 GRADE 60.

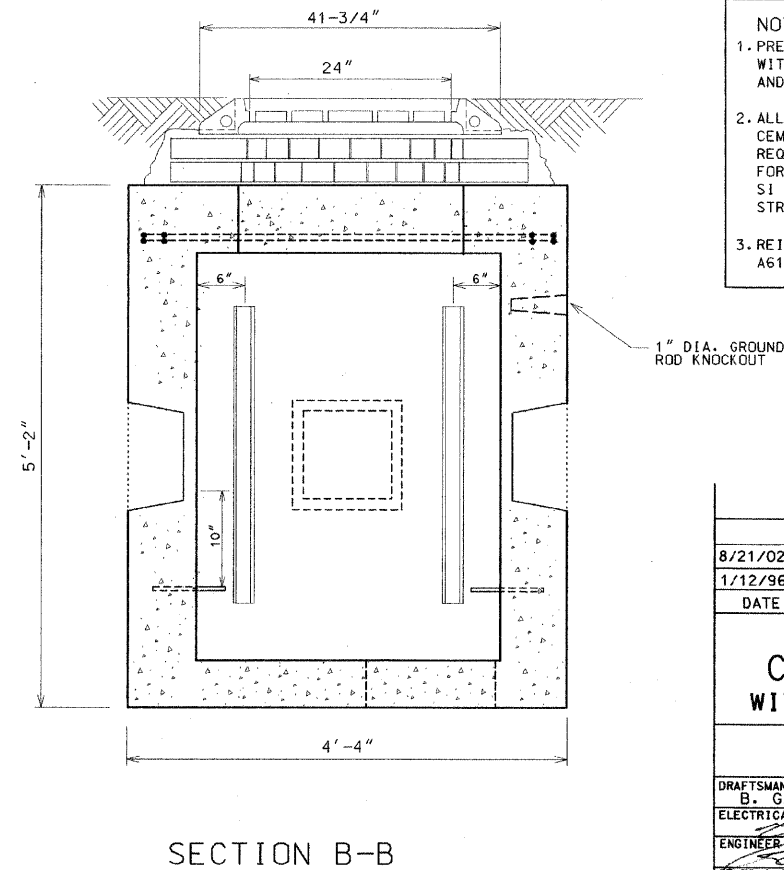
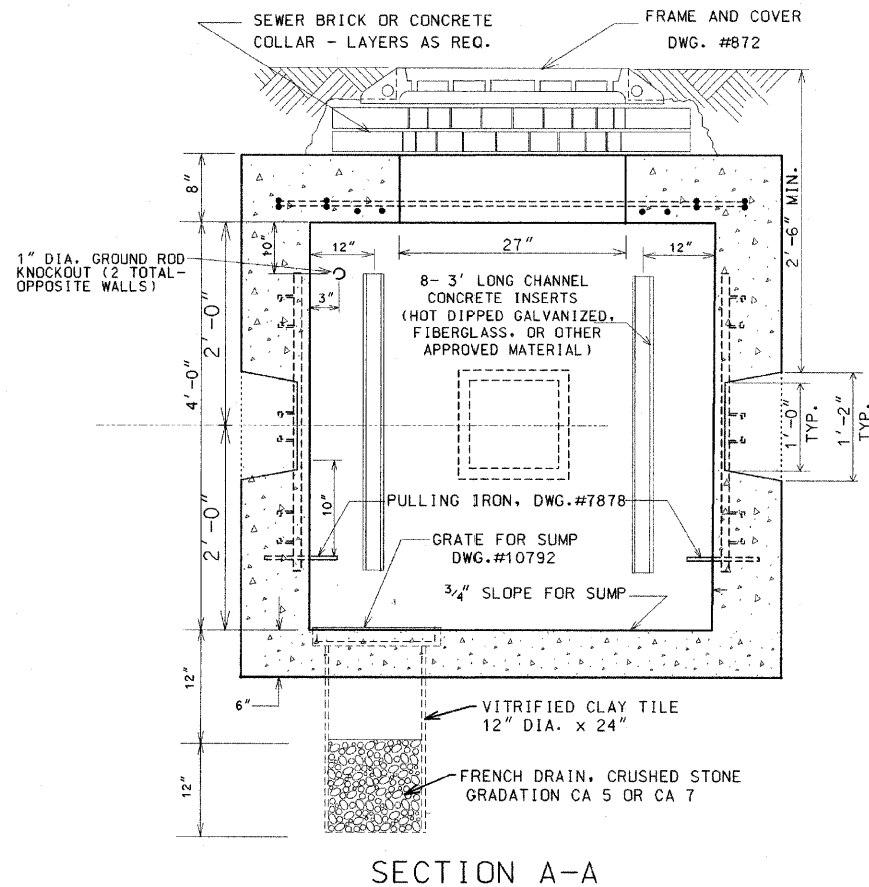

8/21/02	SUPERCEDES DWG. 730 DATED JAN 12, 1996
1/12/96	SUPERCEDES DWG. 730 DATED NOV. 21, 1973
DATE	REVISION
3' x 4' x 4'	
CONCRETE MANHOLE	
WITH 24" FRAME AND COVER	
CITY OF CHICAGO DEPT. OF STREETS AND SANITATION BUREAU OF ELECTRICITY DIVISION OF ELECTRICAL ENGINEERING	
DRAFTSMAN: B. GARNSEY	CHIEF DRAFTSMAN: R. CARTER
ELECTRICAL DESIGN ENGINEER	ENGINEER: B. GARNSEY
ENGINEER OF ELECTRICITY	DRAWING NO. 730
GENERAL SUPERINTENDENT	DATE: 8/21/02
DEPUTY COMMISSIONER	SCALE: NONE
SIZE: 17" x 22"	

REVISIONS	
NAME	DATE

ILLINOIS DEPARTMENT OF TRANSPORTATION

CITY OF CHICAGO
BUREAU OF ELECTRICITY DETAILS

SCALE: NONE
DATE: NOVEMBER 2007

DRAWN BY: K.R.K.
CHECKED BY: S.J.P.

CR & A
CHRISTIAN-ROGE & ASSOCIATES, INC.
ENGINEERS-PLANNERS-SURVEYORS
211 WEST WACKER DRIVE
CHICAGO, ILLINOIS 60606
1-312-372-2023 FAX: 1-312-372-5274