

F.A.I. RTE.	SECTION	COUNTY	TOTAL SHEETS	SHEET NO.
90	1213B-1	COOK	94	66
STA.		TO STA.		
FED. ROAD DIST. NO. 1		ILLINOIS	FED. AID PROJECT	

CONTRACT NO. 60640

BEAM @ REACTION	
Without Concrete Deck	
= 64 kn/Beam @ N. Abut.	
= 75 kn/Beam @ Pier 2	

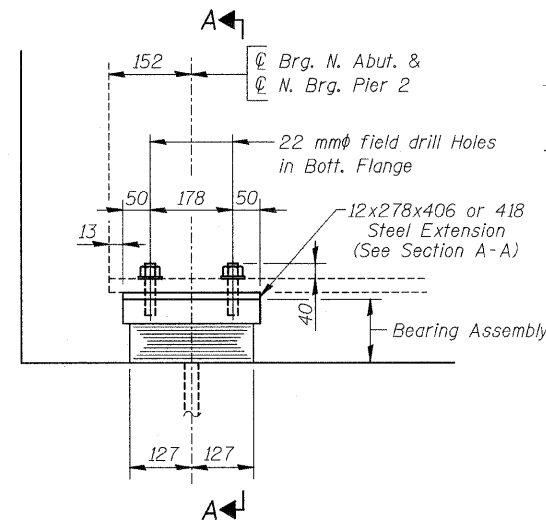

ELEVATION AT N. ABUT. (SHOWN) & N. BRG. PIER 2

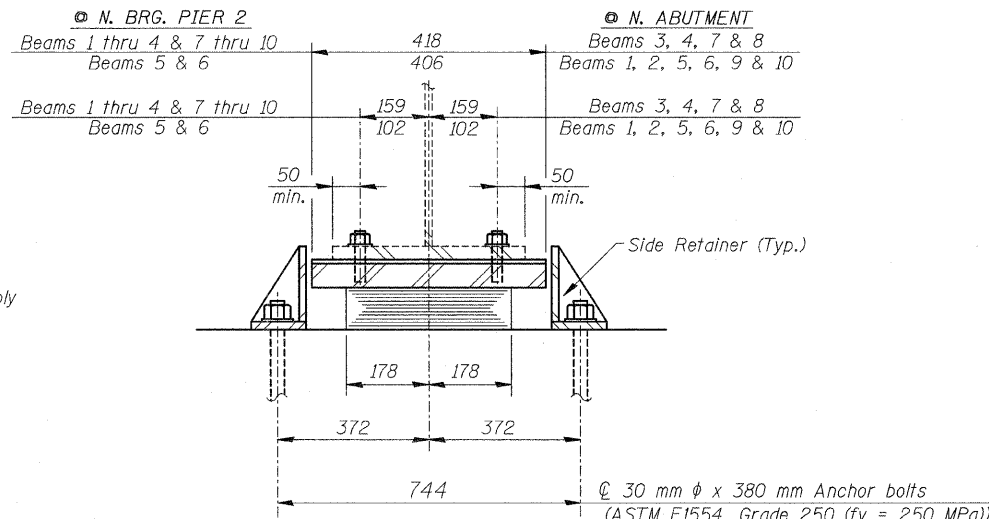

SECTION A-A

TYPE I ELASTOMERIC EXP. BRG.

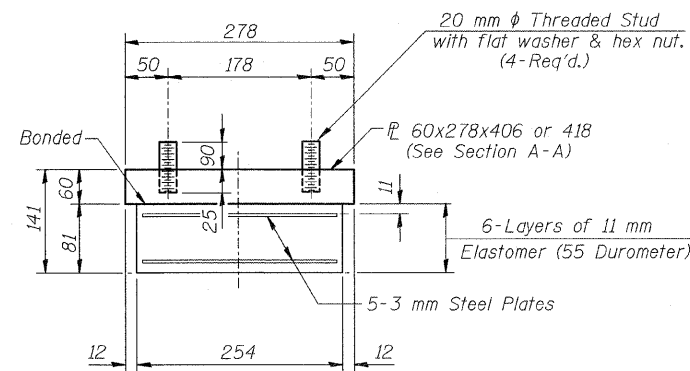

BEARING ASSEMBLY

Note: Shim plates shall not be placed under Bearing Assembly.

BILL OF MATERIAL

Item	Unit	Total
Elastomeric Bearing Assembly, Type I	Each	20
Anchor Bolts, M30	Each	40

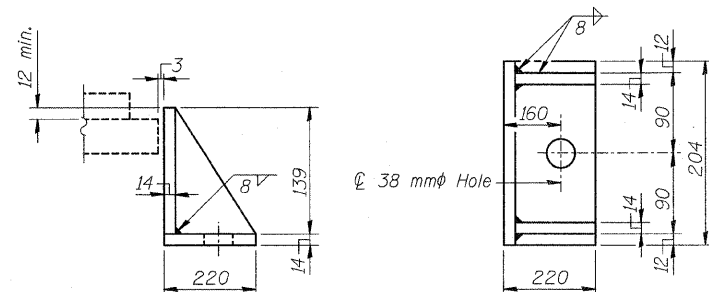

SIDE RETAINER

Equivalent rolled angle with stiffeners will be allowed in lieu of welded plates.

NOTES:

Anchor Bolts shall be ASTM F1554 all-thread (or an Engineer Approved Alternate Material) of the Grade (s) and Diameter (s) specified. ASTM A307 Grade C Anchor Bolts may be used in lieu of ASTM F1554, Grade 250 (fy = 250 MPa). The corresponding specified Grade of AASHTO M314M Anchor Bolts may be used in lieu of ASTM F1554.

Anchor Bolts for Side Retainers may be installed in holes drilled before or after members are in place. Drilled and set Anchor Bolts shall be installed according to Article 521.06 of the Standard Specifications.

Two 3mm Adjusting Shims shall be provided for each Bearing in addition to all other Plates or Shims and placed as shown on the Bearing Details. Side Retainers and other Steel Members required for the Bearing Assembly shall be included in the cost of Elastomeric Bearing Assembly, Type I.

Cost for New Steel Extensions is included with "Furnishing and Erecting Structural Steel".

Bearing Plates & Pintles to be AASHTO M270M, Grade 250.

Diaphragm removal and replacement may be required to facilitate drilling holes in bottom flange for bearing attachment. Cost is included with "Furnishing and Erecting Structural Steel".

All dimensions are in millimeters (mm) except as noted.

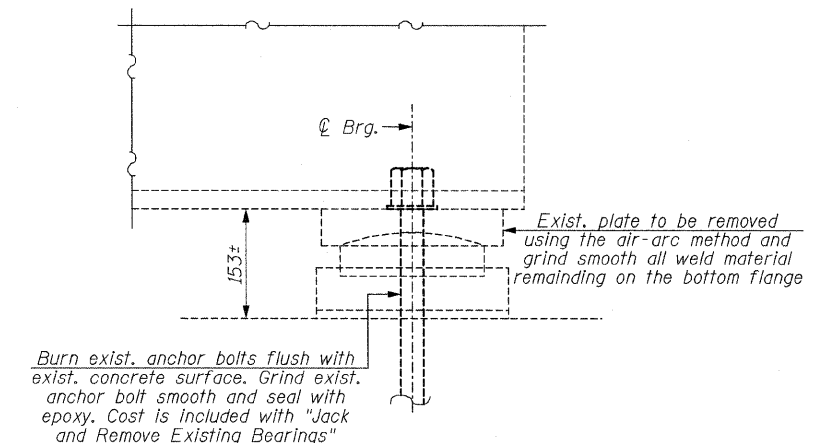

SECTION AT NORTH ABUTMENT AND AT NO. AND SO. BEARINGS @ PIER 2 (Existing Expansion Bearing Removal)

BEARING REPLACEMENT NOTES:

- The Contractor shall submit for approval by the Engineer plans for jacking Existing Superstructure prior to commencing any work at the Bearings. This submittal shall be prepared and sealed by a Licensed Structural Engineer in Illinois.
- Jacking and Removing Existing Bearings shall be done after the existing Deck removal is completed and before the New Deck is poured.
- The New Bearings shall be in place and the jacks shall be lowered before the New Concrete Deck is poured.
- Remove nuts from anchor bolts of bearings at the beams.
- Raise bridge 7 mm maximum (See General Notes below).
- Remove existing expansion bearings at North Abutment and at North & South bearings of Pier 2.
- Install Elastomeric Expansion Bearing on the existing Pedestals.

GENERAL NOTES:

- The Contractor shall supply additional shim plates if required to bring devices to grade. Cost included with Elastomeric Bearing Assembly, Type I.
- Drilling holes for expansion bearings in flanges of existing beams and in existing substructure shall be included in Elastomeric Bearing Assembly, Type I.
- It shall be the Contractor's responsibility to verify all dimensions between the bottom of the girder and the top of the bearing seat of the existing bearings in the field prior to construction or ordering of bearings.

REVISIONS	
NAME	DATE

ILLINOIS DEPARTMENT OF TRANSPORTATION

BEARING DETAILS AT ABUTMENTS CENTRAL AVENUE (F.A.U. RTE. 2798) OVER INTERSTATE 90 (KENNEDY EXPWY.) & C.T.A. F.A.I. RTE. 90 SECTION: 1213B-1 COOK COUNTY STATION 1+000.000 STRUCTURE NO. 016-0659

SCALE: NONE DRAWN BY: D.L./J.M. DATE: JANUARY 16, 2009 CHECKED BY: B.N.S./J.C.N.

CHRISTIAN-ROGE & ASSOC., INC. CHICAGO ILLINOIS

...:\\c:\p\working\drawn\1213b-1_s19.dwg 1/16/2009 7:28:39 AM