

# STAGE II (CONTINUED)

## STAGE II NOTES

- SEQUENCE OF CONSTRUCTION: PAVEMENT PATCHING, HMA SURFACE REMOVAL AND PROPOSED HMA COURSES AS DETAILED IN EACH OPERATION SECTION. WORK CAN OCCUR CONCURRENTLY, BUT SEQUENCE SHALL BE MAINTAINED AND NOT CONFLICT. THE TWO LANE SECTION OF I-94 WILL FOLLOW THE SEQUENCE OF LANES 1 AND 3 IN THE OPERATION SECTIONS. RAMP WORK WILL BE COMPLETED USING DISTRICT DETAIL TC-8 - FREEWAY AND EXIT RAMP CLOSURE DETAILS.
- LANE AND RAMP CLOSURES ALLOWED AS STIPULATED IN THE SPECIAL PROVISIONS.
- HMA SURFACE REMOVAL AND RESURFACING OPERATIONS SHALL NOT BEGIN UNTIL STAGE I IS COMPLETED AND THE I-94 ALTERNATE ROUTE IS SET UP.
- LANE CLOSURES PER STANDARDS 701400, 701401 AND 701446.
- REDUCE LANE WIDTH USING 35:1 TAPER PER DISTRICT DETAIL TC-9 - TRAFFIC CONTROL DETAILS FOR FREEWAY SINGLE AND MULTI-LANE WEAVE, A W5-1 (48 x 48) ROAD NARROWS SIGN WILL BE ERECTED 500' IN ADVANCE OF THE TAPER.
- THE CONTRACTOR SHALL ERECT ROAD CONSTRUCTION AHEAD SIGNS (W20-1103(O-48) WITH FLASHING BEACON ON ALL ARTERIAL ROADWAYS APPROACHING INTERCHANGE RAMPS.
- GRADE DIFFERENTIAL BETWEEN LANES SHALL NOT EXCEED 2".
- PARTIAL MILLING OF PAVEMENT FOR AN OPERATION WILL NOT BE PAID FOR SEPARATELY, BUT WILL BE PAID FOR AT THE FINAL MILLING THICKNESS SHOWN ON THE TYPICAL SECTIONS.
- REMOVAL OF TEMPORARY PAVEMENT MARKING, WHEN REQUIRED, SHALL BE PAID FOR AS "WORK ZONE PAVEMENT MARKING REMOVAL".
- REMOVAL OF EXISTING PAVEMENT MARKING, WHEN REQUIRED, SHALL BE PAID FOR AS "PAVEMENT MARKING REMOVAL".
- EXISTING OR TEMPORARY PAVEMENT MARKINGS REMOVED DURING MILLING OPERATIONS WILL NOT BE PAID FOR SEPARATELY.
- CASTINGS EXPOSED IN TRAVEL LANES SHALL BE PROTECTED PER APPLICABLE PORTIONS OF ARTICLE 603.07 OF THE STANDARD SPECIFICATIONS. THIS WORK WILL NOT BE PAID FOR SEPARATELY, BUT SHALL BE INCLUDED IN THE VARIOUS HMA BINDER AND SURFACE COURSES PLACED.

## LEGEND

- ① EXISTING PAVEMENT MARKING
- ② WET REFLECTIVE TEMPORARY TAPE, TYPE III, 5" (10' DASH - 30' SKIP)
- ③ WET REFLECTIVE TEMPORARY TAPE, TYPE III, 4" (YELLOW LEFT & WHITE RIGHT) INSTALLED WITHIN 24 HOURS OF MILLING OR BINDER PLACEMENT.
- ④ PROPOSED PAVEMENT MARKING. SEE PAVEMENT MARKING PLANS.
- ⑤ VERTICAL BARRICADES WITH STEADY BURNING MONO DIRECTIONAL LIGHT AT 100' C-C SPACING. VERTICAL BARRICADES ALONG SHOULDERS WILL REMAIN IN PLACE BETWEEN OPERATIONS TO PREVENT SHOULDER RIDING. DURING EACH OPERATION VERTICAL BARRICADES WILL THEN BE USED TO SEPARATE THE WORK ZONE AND OPERATING LANES.

- BITUMINOUS SURFACE REMOVAL
- HMA SURFACE COURSE

## NOTE

STRUCTURAL WORK ON BRIDGES TO BE ACCOMPLISHED IN STAGE II DURING ALLOWABLE SHOULDER AND LANE CLOSURES IDENTIFIED IN THE SPECIAL PROVISIONS. THE CONTRACTOR SHALL COORDINATE THE ROADWAY AND STRUCTURAL WORK SO BITUMINOUS MATERIALS ARE NOT TRACKED ON THE BRIDGE DECKS BEFORE BEING SEALED.

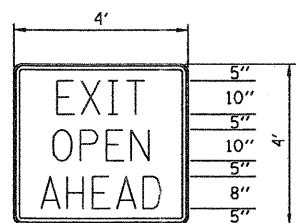

1" BORDER LINE  
GREEN REFLECTIVE BACKGROUND  
WITH WHITE LEGEND

THIS SIGN SHALL BE INSTALLED  
IN ADVANCE OF ALL OPEN/EXIT  
RAMPS WHEN THE RIGHT  
LANES ARE CLOSED.



W8-11  
48" x 48"

NOTE:  
THIS SIGN SHALL BE INSTALLED  
ON BOTH SIDES OF THE ROADWAY  
500' IN ADVANCE OF AREAS WHERE  
THERE IS A GRADE DIFFERENTIAL  
BETWEEN LANES, AFTER EACH  
ENTRANCE RAMP AND A MINIMUM  
OF EVERY MILE.

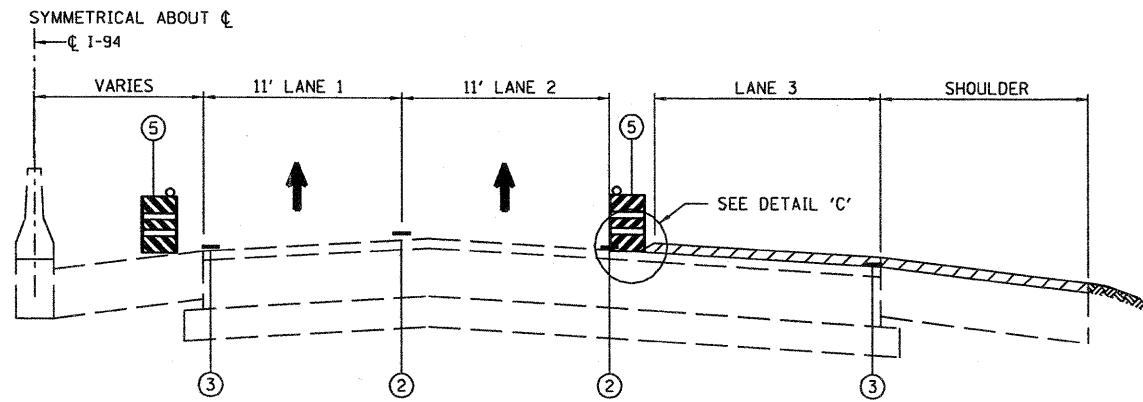

STAGE II - OPERATION FOUR - I-94  
HMA SURFACE REMOVAL 2" - LANE 3 & OUTSIDE SHOULDER

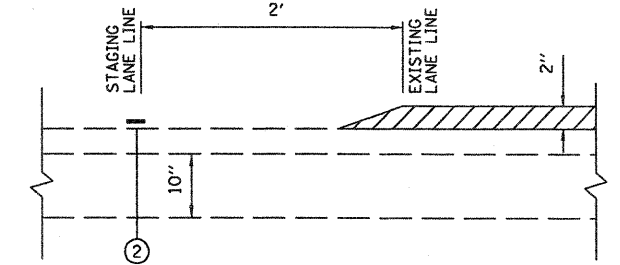

DETAIL 'C'

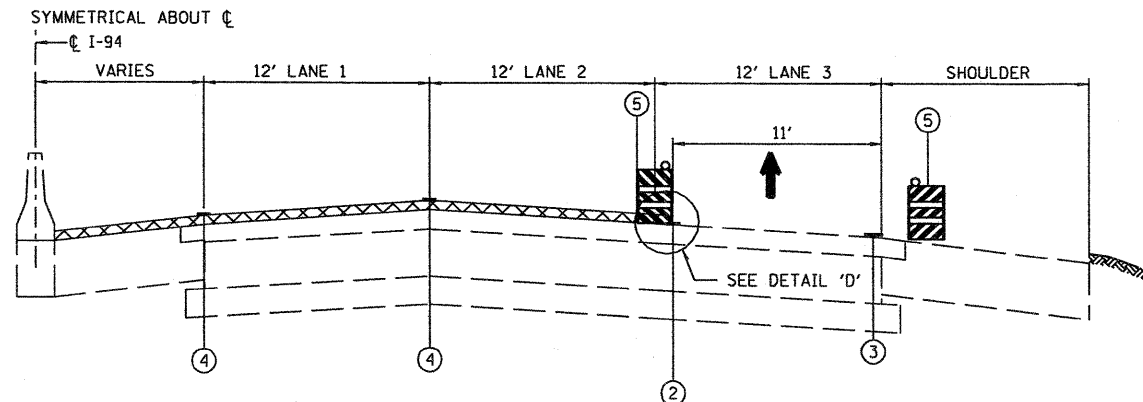

STAGE II - OPERATION FIVE - I-94  
PLACE SURFACE 2" - LANES 1 & 2 & INSIDE SHOULDER

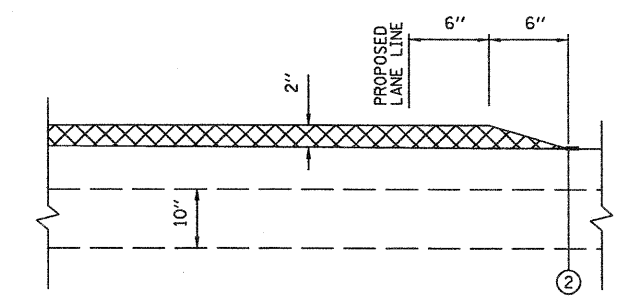

DETAIL 'D'

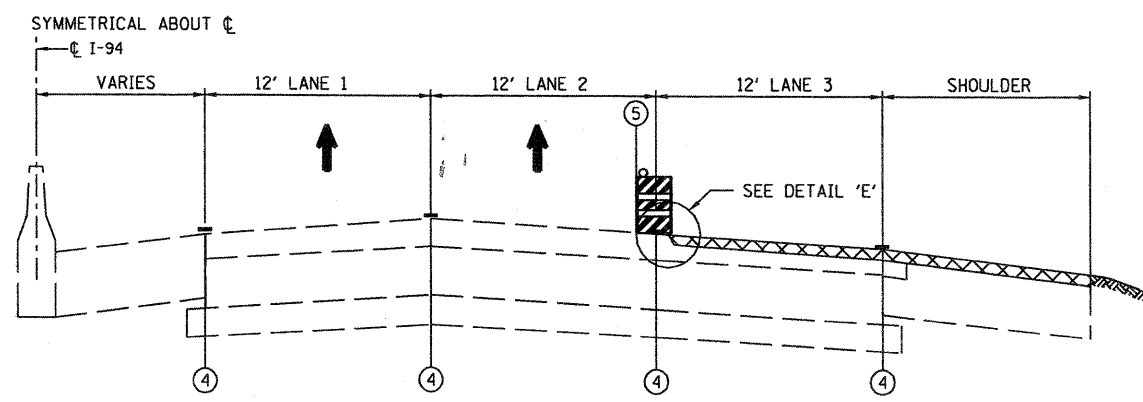

STAGE II - OPERATION SIX - I-94  
PLACE SURFACE 2" - LANE 3 & OUTSIDE SHOULDER

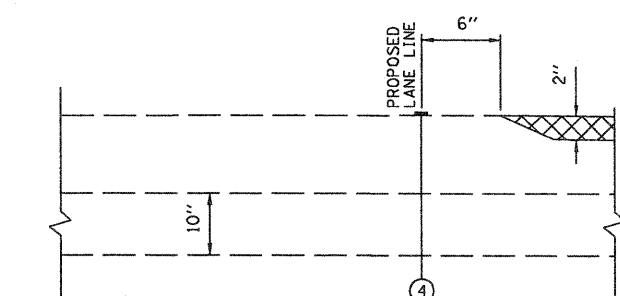

DETAIL 'E'

FILE NAME = D160C08-064-STAGE.II.B.dgn	USER NAME = dvoznarski	DESIGNED - DRAWN - DMW	REVISED - REVISED - REVISED - REVISED -	STATE OF ILLINOIS DEPARTMENT OF TRANSPORTATION		BISHOP FORD EXPRESSWAY (I-94) SUGGESTED MAINTENANCE OF TRAFFIC		F.A.I. RTE.	SECTION	COUNTY	TOTAL SHEETS	SHEET NO.
	PLOT SCALE = N/A	CHECKED - DATE - 2/6/2009						94	0312-708W, ETC. & 1315RS-4	COOK	167	64
				SCALE: N/A	SHEET NO. 5 OF 9 SHEETS	STA.	TO STA.	FED. ROAD DIST. NO. [ILLINOIS] FED. AID PROJECT				