

STATE OF ILLINOIS
DEPARTMENT OF TRANSPORTATION

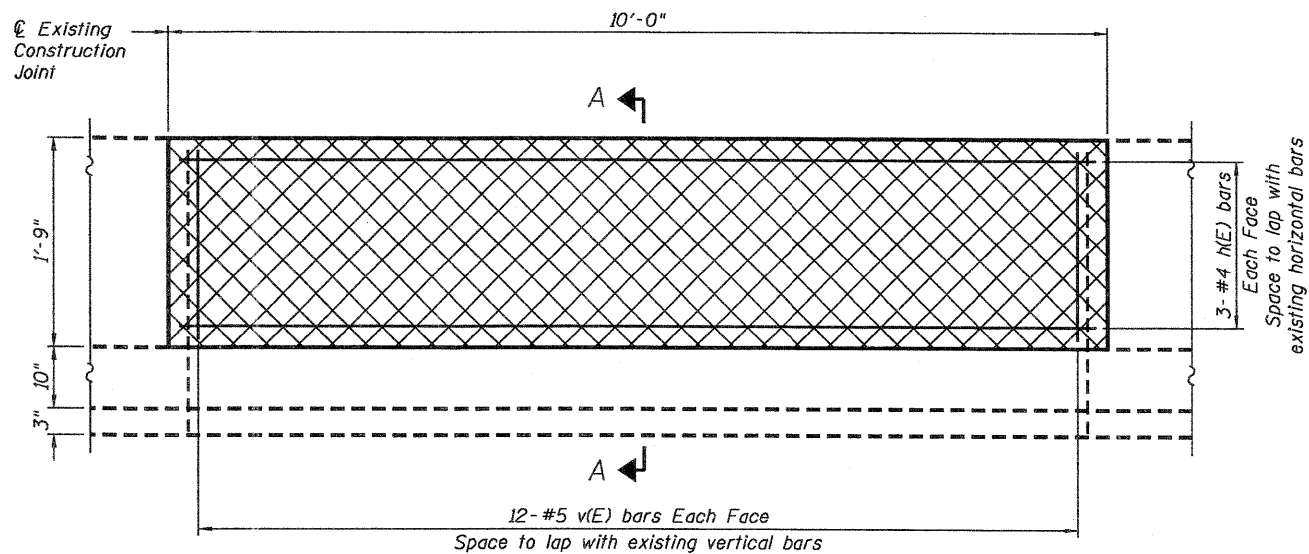

BARRIER REPAIR
SN 016-0153

Existing reinforcement shall be cleaned and incorporated into the new construction. Cost included with Concrete Removal.

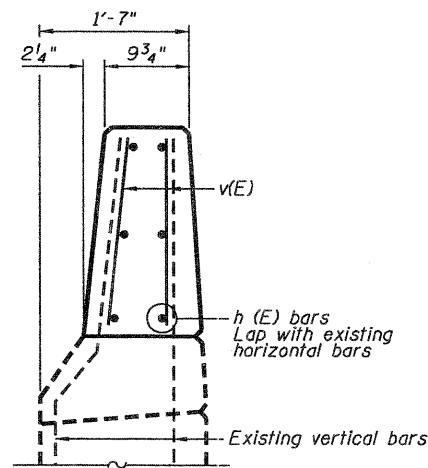
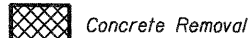

SECTION A-A

BILL OF MATERIAL - BRIDGE 016-0153

Bar	No.	Size	Length	Shape
h(E)	6	#4	9'-8"	—
v(E)	24	#5	1'-5"	—
Item		Unit	Quantity	
Concrete Removal		Cu. Yd.	0.6	
Concrete Superstructures		Cu. Yd.	0.6	
Reinforcement Bars (Epoxy Coated)		Pound	70	

Reinforcement bars shall conform to the requirements of ASTM A 706 Gr 60. See Special Provisions.

Reinforcement bars designated (E) shall be epoxy coated.

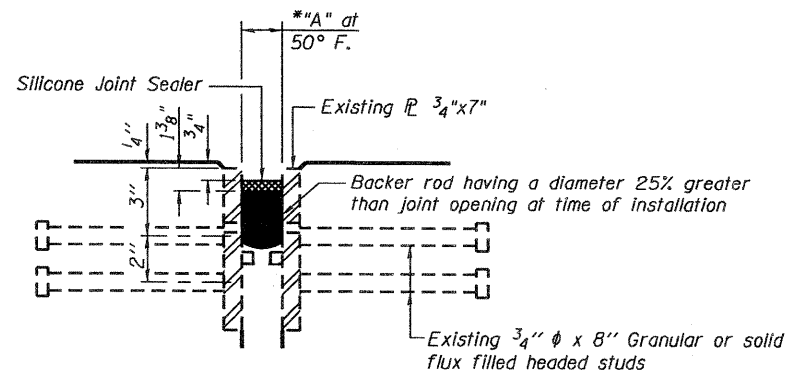

SILICONE JOINT SEALER DETAIL
AT EXISTING PREFORMED JOINT SEAL

*See Table A

TABLE A

Structure Number	Location	"A"
016-0158	Joint 1	2 3/4"
016-0158	Joint 2	2 3/4"
016-0158	Joint 3	2 3/4"
016-0158	Pier 4	2 3/4"
016-0159	Pier 4	2 3/4"
016-0160	N. Abutment	2 3/4"
016-0161	N. Abutment	2 3/4"
016-0161	S. Abutment	1 3/4"

Note:

The contract unit price for "feet" for Silicone Joint Sealer of the size specified shall include removal of the existing silicone joint sealer and backing rod or the removal of the existing preformed joint seal and 1/2"x1/2" steel bars as necessary. The existing steel plates and anchor bolts shall be reused.

DESIGNED	LAS
CHECKED	DAZ
DRAWN	SAW
CHECKED	LAS

ZROKA
engineering
Zroka Engineering, P.C.
4216 North Hamlette
Chicago, IL 60613

SHEET NO. 12 OF 13 SHEETS	F.A.I. RTE.	SECTION	COUNTY	TOTAL SHEETS	SHEET NO.
	94	(0312-708W, ETC. & 1315)RS-4	COOK	167	120
S.N. VARIES			CONTRACT NO. 60C08		
FED. ROAD DIST. NO. 7 ILLINOIS FED. AID PROJECT					

**BARRIER WALL AND
JOINT REPAIR DETAILS**
BISHOP FORD EXPRESSWAY (I-94)
COOK COUNTY
STATION 118+00 TO 485+91
VARIOUS BRIDGES