

STATE OF ILLINOIS
DEPARTMENT OF TRANSPORTATION

The Contractor shall exercise extreme care with the existing conduits in sections of the parapet to be removed and to protect and support the conduit. The Contractor will be required to repair any damage done to the conduit to the satisfaction of the Engineer. No splicing will be allowed to any cable damage resulting from this work, instead the Contractor will be required to repair the entire span of any damaged cable.

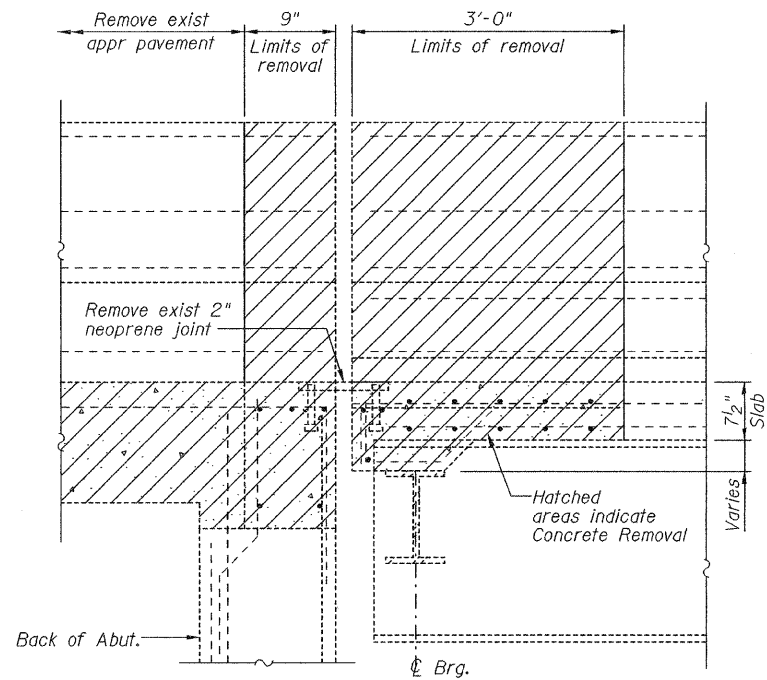

SECTION A-A

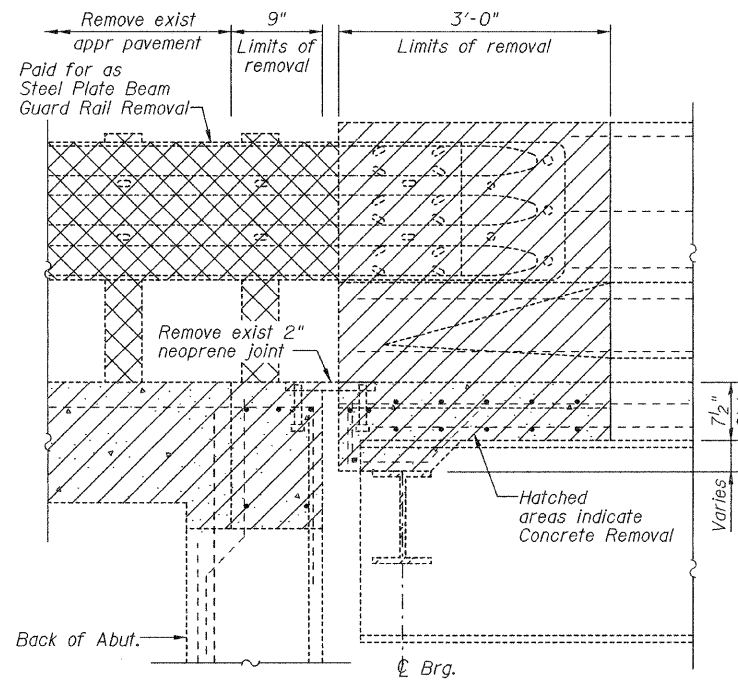

SECTION B-B

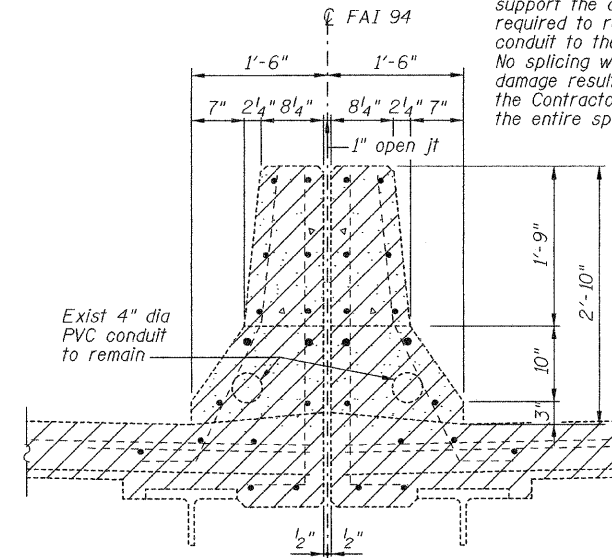

MEDIAN PARAPET
SECTION C-C

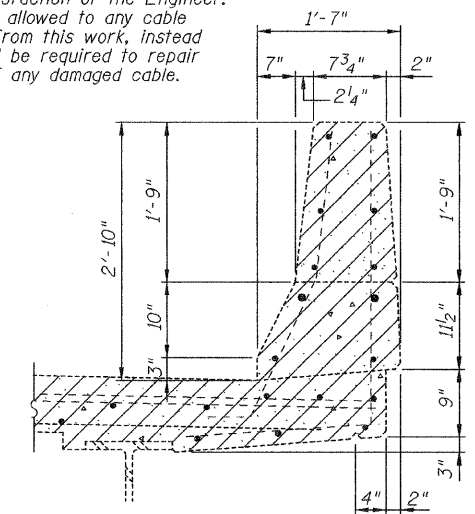

EB & WB PARAPET
SECTION D-D

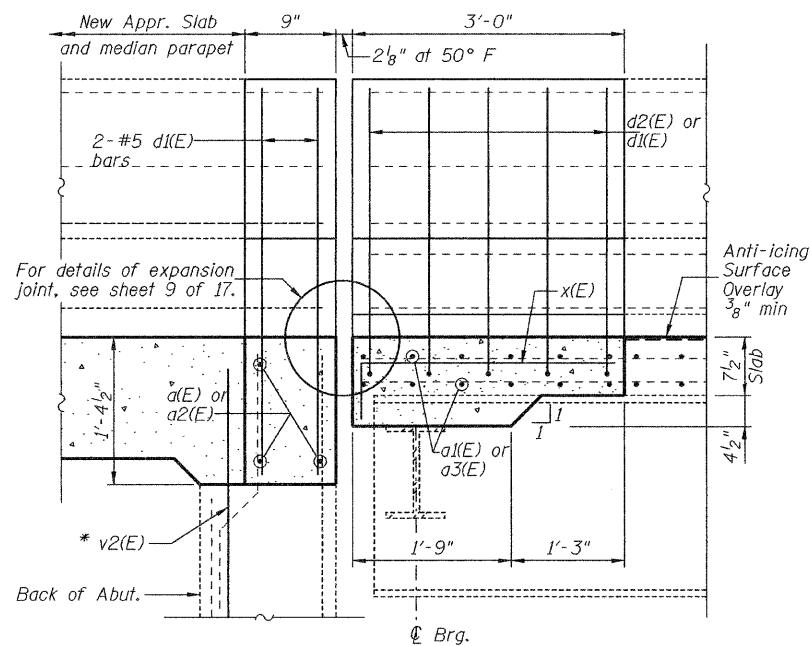

SECTION E-E

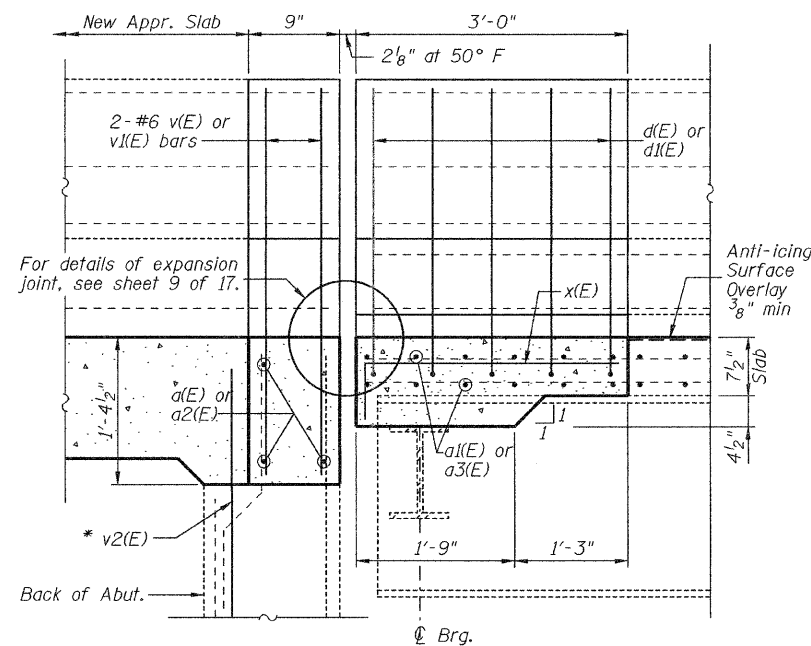

SECTION F-F

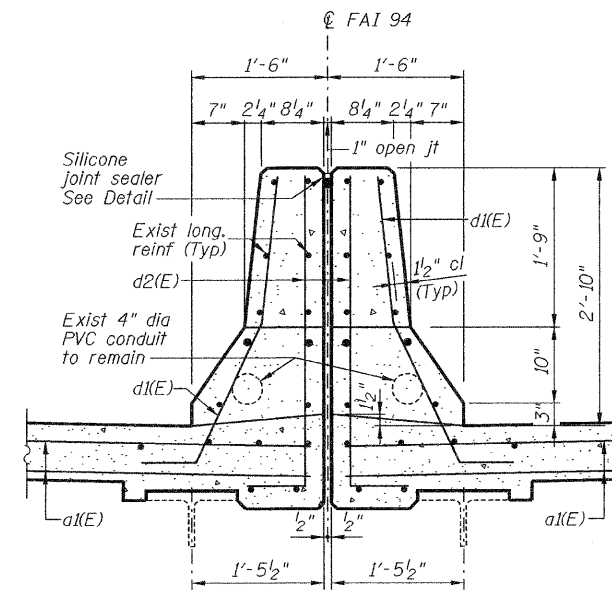

MEDIAN PARAPET
SECTION G-G

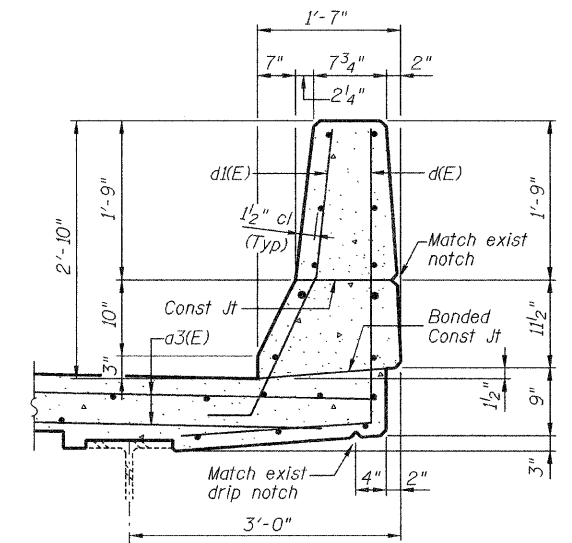

EB & WB PARAPET
SECTION H-H

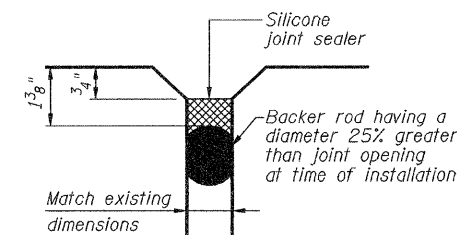

SILICONE BRIDGE JOINT SEALER
(Typical entire length of bridge)

* See details on sheets 16 & 17 of 17.

EXPANSION JOINT REMOVAL AND
REPLACEMENT DETAILS 1
BISHOP FORD EXPRESSWAY (I-94)
LITTLE CALUMET RIVER
COOK COUNTY
STATION
STRUCTURE NUMBER 016-0163

DESIGNED -	
CHECKED -	
DRAWN -	
CHECKED -	

HOMER L. CHASTAIN & ASSOCIATES, LLP
CONSULTING ENGINEERS
DECATUR (217) 422-8544
CHICAGO (773) 714-0050
ROCKFORD (815) 489-0050
184-001397

SHEET NO. 7 OF 17 SHEETS	F.A.I. RTE. 94	SECTION (0405,ETC,42-7&0707)RS-11	COUNTY COOK	TOTAL SHEETS 133	SHEET NO. 93
	BISHOP FORD EXPRESSWAY (I-94)		CONTRACT NO. 60D21		
FED. ROAD DIST. NO. - ILLINOIS FED. AID PROJECT					