

F.A.I. RTE.	SECTION	COUNTY	TOTAL SHEETS	SHEET NO.
57	2021.IB-R	COOK	101	047
STA.	TO STA.			
FED. ROAD DIST. NO. 1		ILLINOIS	FED. AID PROJECT	
CONTRACT NO. 62532				

TOP VIEW  
FRAME, COVER & TOP  
OF HANDHOLE REMOVED

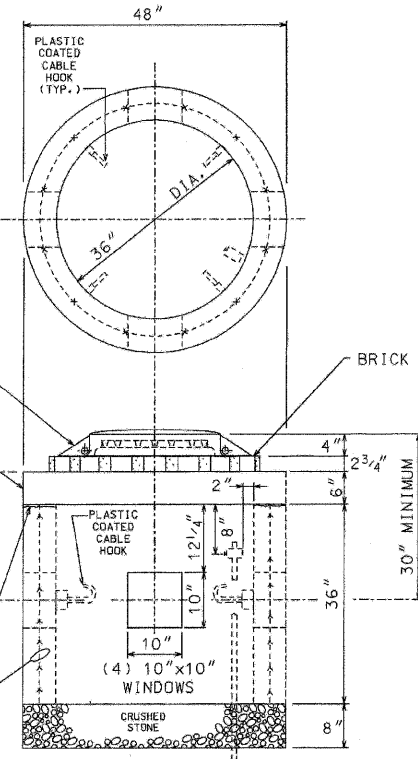

SIDE  
ELEVATION

COMPLETE COMMODITY CODE NO. 05-6610-5310M

CODE NO.	MATERIALS	SIZE	QUAN.
(1) 05-6610-5312	PRE-CAST HANDHOLE	36" X 36"	
(2) 05-6610-5312	PRE-CAST ROOF	SEE DETAIL	1
05-9075-5470	STONE 3/4" CRUSHED SCREENINGS	BAG	5
05-1452-9720	BRICK		24
02-4299-5524	FRAME, MANHOLE	24"	1
02-4574-5624	COVER, MANHOLE	24"	1
09-7796-9312	GROUND ROD	3/4" X 12'	1
09-2636-3240	GROUND CLAMP		1
(3) 05-5082-5330	SONO TUBE	36"	1
(3) 05-5082-5342	SONO TUBE	48"	1
(3) 05-3267-2940	CONC. REDI-MIX	CU. YD.	3/4
(3) 20-5472-9630	REINFORCING BAR	#3 (3/8")	20'
(3) 20-5472-9630	REINFORCING BAR	#3 (3/8")	8'
(3) 20-5472-9640	REINFORCING BAR	#4 (1/2")	4'
(3) 57-0770-0000	(MESH (6" X 6"))	36" X 11'	1

- (1) PRE-CAST HANDHOLE SHALL INCLUDE CABLE HOOKS AND CONDUIT KNOCK-OUTS.
- (2) PRE-CAST ROOF SHALL INCLUDE LIFTING EYES.
- (3) THESE ITEMS ARE FOR POURED-IN-PLACE HANDHOLES ONLY.

CONSTRUCTION NOTES:

- 1 - 8" BED OF STONE FOR DRAINAGE.
- 2 - ALL METALLIC CONDUIT(S) ENTERING HANDHOLE SHALL EXTEND MIN. 1" & MAX. OF 3" INSIDE INNER WALL & BE EQUIPPED WITH AN APPROVED TYPE THREADED GROUNDING BUSHING.

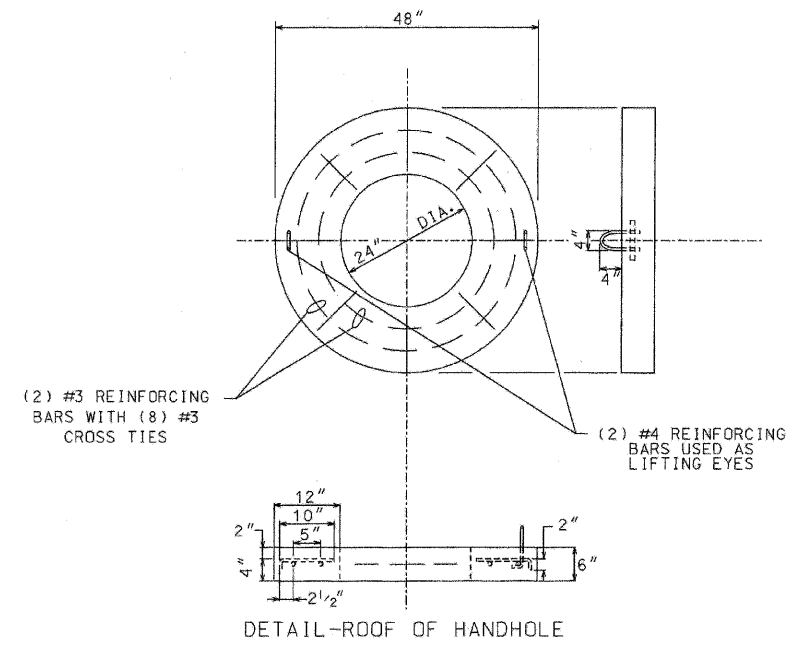

DETAIL-ROOF OF HANDHOLE

DATE	REVISION
01-23-00	ADDED CABLE HOOKS PER COMMISSIONER MURPHY (RC/RD)
	REDRAW (CAD.) (MP)

36" DIA. HEAVY DUTY  
CONCRETE HANDHOLE  
WITH 24" FRAME &  
COVER

CITY OF CHICAGO  
DEPT. OF STREETS AND SANITATION  
DIVISION OF ELECTRICAL ENGINEERING

DRAFTSMAN M. PATTON	CHIEF DRAFTSMAN B. CARTER	ENGINEER W. TROMPKA
SUPERVISING ENGINEER ELEC. DESIGN ENGR.		W. DEBARTOLO
ENGINEER OF ELECTRICITY		
DEPT. SUPV. OF ELECTRICITY		
DEPUTY COMMISSIONER		
SIZE: 17" x 22"	SCALE: NONE	DATE: 1-12-96

DWG. NO. 866

\$\$\$CHAS7ECSH  
\$\$\$FORAS7ECSH  
\$\$\$DWL#7ECSH  
\$\$\$PEN#7ECSH

REVISIONS	
NAME	DATE

ILLINOIS DEPARTMENT OF TRANSPORTATION  
111TH STREET OVER  
F.A.I ROUTE 57 (INTERSTATE 57)

ELECTRICAL STANDARD DETAILS

SCALE: NONE DRAWN BY: N/A  
DATE: 01/16/09 CHECKED BY: N/A

**TENG**  
TENG & ASSOCIATES, INC.  
ENGINEERS, ARCHITECTS, PLANNERS  
205 N. MICHIGAN AVE., CHICAGO, IL 60601  
TELEPHONE: 312/616-0000

WITH ST. BORBER.DGN  
 1-16-2009 10:48:21  
 T:\DOCUMENT\9300866\CIVIL\DON\K\H08\00.DGN  
 12 13 14 15 16 17 18 19 20 21 22 23 24 25 26 27 28 29 30 31 32 33 34 35 36 37 38 39 40 41 42 43 44 45 46 47 48 49 50 51 52 53 54 55 56 57 58 59 60 61 62 63  
 RECHT BR  
 60 61 62 63