

F.A.P. RTE.	SECTION	COUNTY	TOTAL SHEETS	SHEET NO.
71	*	IROQUOIS	9	9
STA.		TO STA.		
FED. ROAD DIST. NO.		ILLINOIS FED. AID PROJECT		

*112RS-4 & 113RS-2

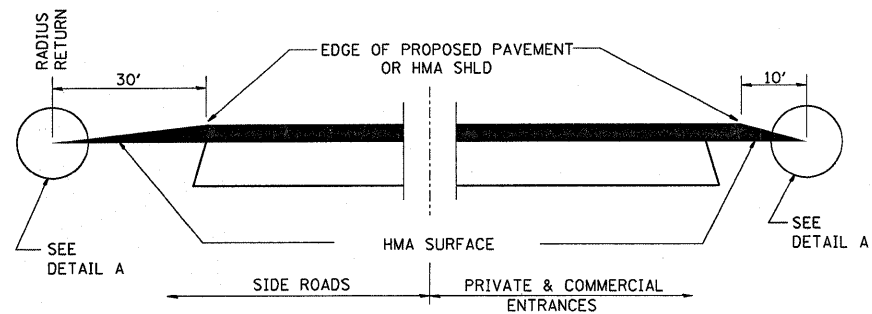

SECTION A-A
DETAILS AT ENTRANCES & SIDE ROADS

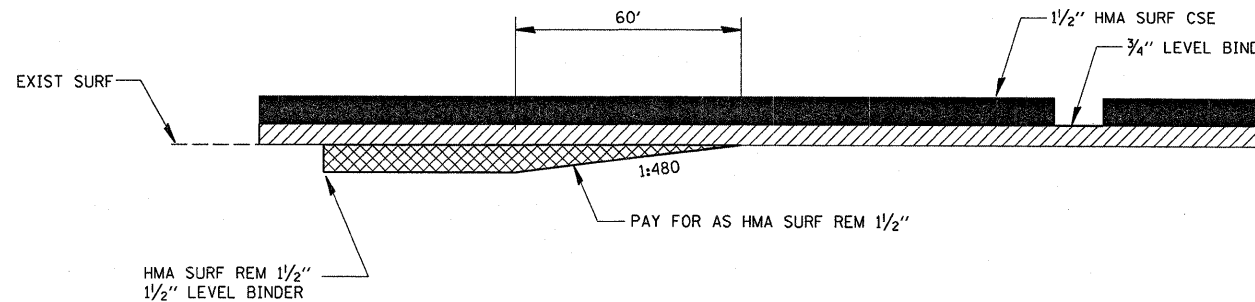

HMA TAPER
133+40 TO 134+00 EB
144+54 TO 145+14 EB

THE COST OF REMOVAL AT EXISTING HMA OR P.C.C. LOCATIONS SHALL BE PAID FOR PER SQ YD BY THE APPROPRIATE PAY ITEM. REMOVAL AT EXISTING AGG. LOCATIONS SHALL BE INCIDENTAL TO THE HMA. A-3 LOCATIONS SHALL BE FEATHER TAPERED.

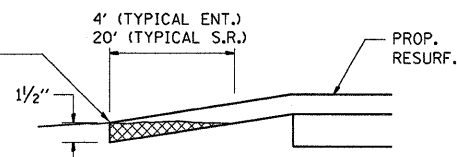

DETAIL A

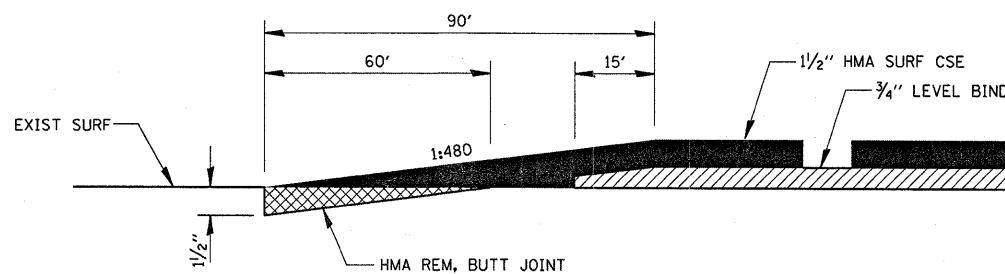

HMA REM-BUTT JOINT
44+40 TO 45+30
195+40.58 TO 196+30.58
197+11.96 TO 198+01.96
216+90 TO 217+80
225+80 TO 226+70
267+40 TO 268+30

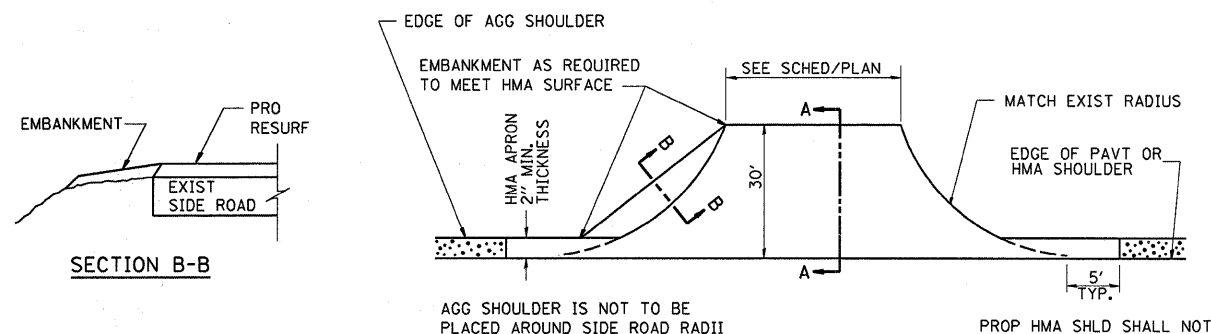

PLAN AT SIDE ROADS

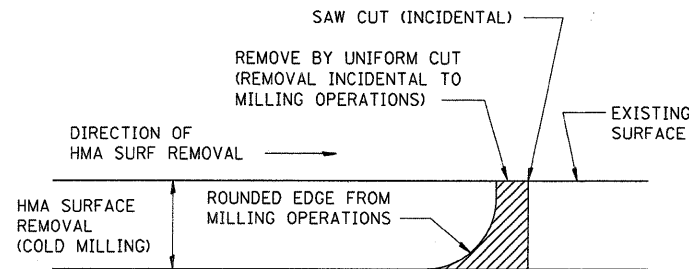

NOTE: WHEN MILLING OPERATIONS PRODUCE A ROUNDED EDGE, THEN A SAW CUT SHALL BE USED TO MANUFACTURE A PERPENDICULAR EDGE AS SHOWN IN THE DETAIL. THE ENGINEER SHALL BE THE SOLE JUDGE CONCERNING THE USE OF THIS DETAIL.

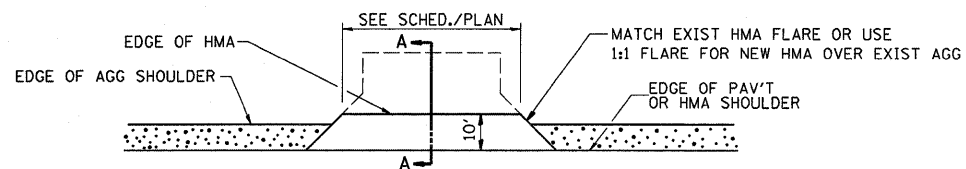

PLAN AT PRIVATE & COMMERCIAL ENTRANCES
(DO NOT RESURFACE FIELD ENTRANCES)

DETAILS

HMA DETAIL AT BUTT JOINTS