

F.A.P. RTE.	SECTION	COUNTY	TOTAL SHEETS	SHEET NO.
71		LOGAN	14	1

• 10(RS-2); 11(RS-2)

STATE OF ILLINOIS
 DEPARTMENT OF TRANSPORTATION
 DIVISION OF HIGHWAYS
**PROPOSED
 HIGHWAY PLANS**

FAP ROUTE 71 (IL 54)
 SECTION 10(RS-2); 11(RS-2)
 PROJECT ESP - 0071 (116)
 LOGAN COUNTY
 C-96-556-07

D-96-560-03

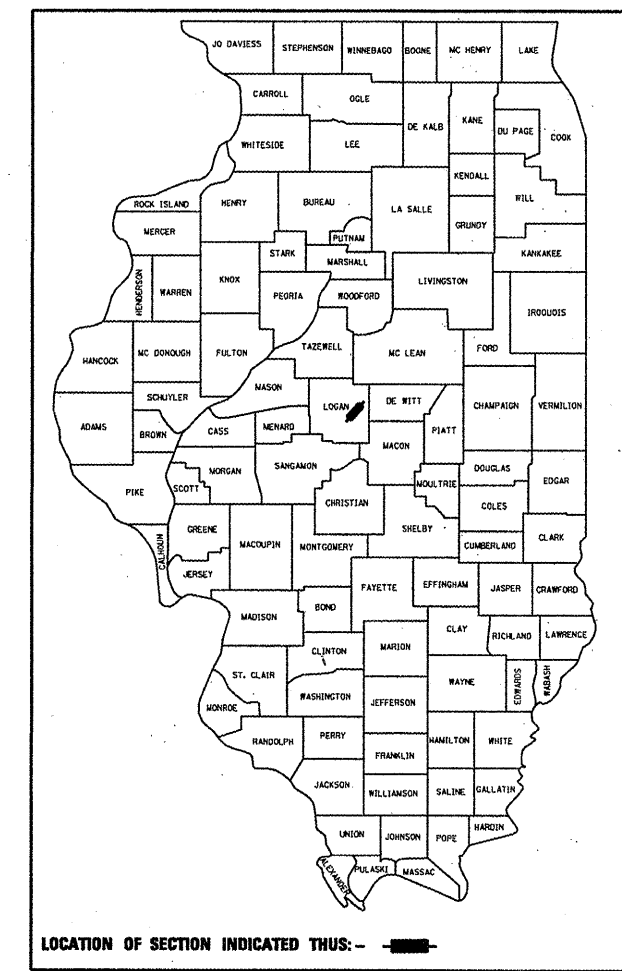

INDEX OF SHEETS

1	COVER SHEET
2	GENERAL NOTES
3-4	SUMMARY OF QUANTITIES
5	SCHEDULE OF QUANTITIES
6	TYPICAL SECTIONS
7-8	ALIGNMENT SHEETS
9	SUPERELEVATION TRANSITION DETAILS
10	BUTT-JOINT DETAILS
11-14	SIDE ROAD AND ENTRANCE DETAILS

LIST OF STANDARDS

000001-05	701301-03
442201-03	701306-02
701001-02	701311-03
701006-03	701901-01
701011-02	780001-02
701201-03	781001-03

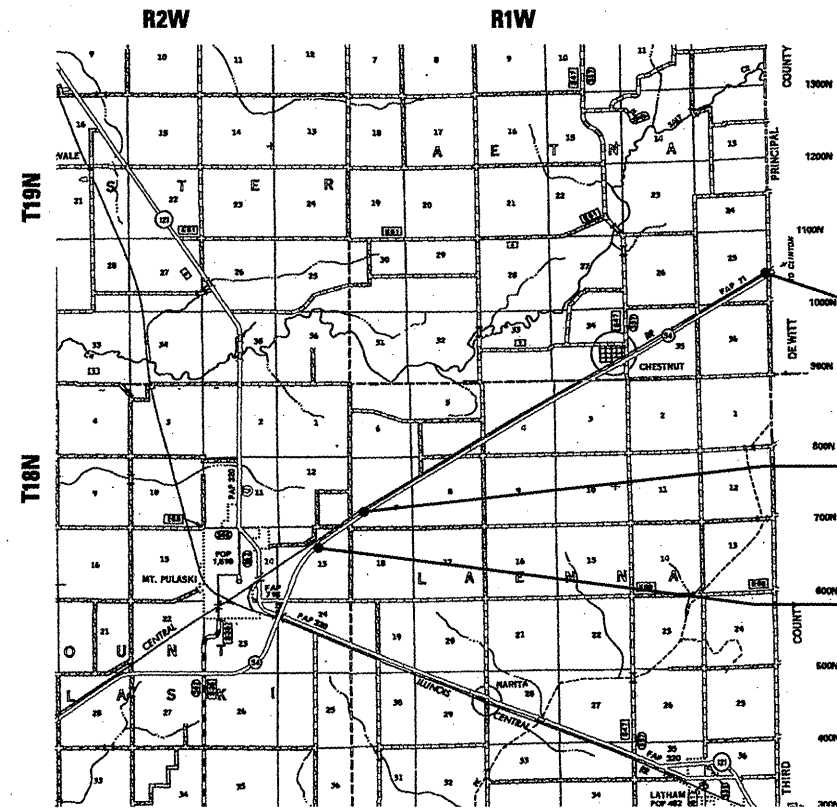

END PPP PROJECT
 STA. 450 + 44 ± [R2]

STATION EQUATION
 118 + 26.00 [R1] (BK) =
 118 + 28.90 [R2] (AH)

BEGIN PPP PROJECT
 STA. 82 + 38.5 ± [R1]

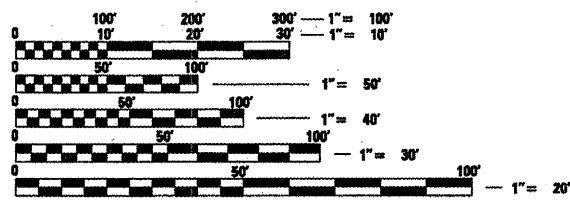

FULL SIZE PLANS HAVE BEEN PREPARED USING STANDARD ENGINEERING SCALES. REDUCED SIZED PLANS WILL NOT CONFORM TO STANDARD SCALES. IN MAKING MEASUREMENTS ON REDUCED PLANS, THE ABOVE SCALES MAY BE USED.

J.U.L.I.E.
 JOINT UTILITY LOCATION INFORMATION FOR EXCAVATION
 1-800-892-0123

APPROXIMATE SCALE: 0 2 4 MILES
 TOTAL LENGTH OF PROJECT = 36,802.60 = 6.97 MILES
 HIGHWAY CLASSIFICATION = MINOR ARTERIAL
 ADT = 1630 (2007) ADT = 1970 (2027)
 87.5% PV3.0% SU9.5% MU

STATE OF ILLINOIS
 DEPARTMENT OF TRANSPORTATION
 DIVISION OF HIGHWAYS
 SUBMITTED January 23, 2009
Roger Z. Jank
 DEPUTY DIRECTOR OF HIGHWAYS, REGION ENGINEER
March 13, 2009
Charles J. Ingersoll
 ENGINEER OF DESIGN AND ENVIRONMENT
March 13, 2009
Christine M. Reed
 DIRECTOR OF HIGHWAYS, CHIEF ENGINEER

**PRINTED BY THE AUTHORITY
 OF THE STATE OF ILLINOIS**

PROJECT ENGINEER: JOHN NEGANGARD (217) 782-6890
 SQUAD LEADER: MARK DUST (217) 785-0587

F.A.P. RTE.	SECTION	COUNTY	TOTAL SHEETS	SHEET NO.
71	*	LOGAN	14	2
STA.		TO STA.		
FED. ROAD DIST. NO.		ILLINOIS FED. AID PROJECT		
* 10(RS-2); 11(RS-2)				

GENERAL NOTES

1. THE LOCATIONS OF EXISTING WATER MAINS, GAS MAINS, SEWERS, ELECTRIC POWER LINES, TELEPHONE LINES AND OTHER UTILITIES AS SHOWN ON THE PLANS ARE BASED ON CAREFUL FIELD INVESTIGATION AND THE BEST INFORMATION AVAILABLE, BUT THEY ARE NOT GUARANTEED. IT SHALL BE THE RESPONSIBILITY OF THE CONTRACTOR TO ASCERTAIN THEIR EXACT LOCATION FROM THE UTILITY COMPANIES AND BY FIELD INSPECTION.
2. WHERE SECTION OR SUBSECTION MONUMENTS ARE ENCOUNTERED, THE ENGINEER SHALL BE NOTIFIED BEFORE SUCH MONUMENTS ARE REMOVED. THE CONTRACTOR SHALL PROTECT AND CAREFULLY PRESERVE ALL PROPERTY MARKERS AND MONUMENTS UNTIL THE OWNER, AN AUTHORIZED SURVEYOR, OR AGENT, HAS WITNESSED OR OTHERWISE REFERENCED THEIR LOCATION.
3. EXISTING ROAD SIGNS THAT CONFLICT WITH STAGE CONSTRUCTION TRAFFIC PATTERNS SHALL BE COVERED OR REMOVED UNTIL NORMAL TRAFFIC PATTERNS ARE RE-ESTABLISHED.
4. ACCESS TO ALL ENTRANCES AND SIDE ROADS SHALL BE MAINTAINED AT ALL TIMES.
5. ANY REFERENCE TO A STANDARD IN THESE PLANS SHALL BE INTERPRETED TO MEAN THE EDITION AS INDICATED BY THE SUB-NUMBERS LISTED IN THE INDEX OF SHEETS, OR THE COPY OF THE STANDARD INCLUDED IN THESE PLANS.
6. IN ADDITION TO FIELD SURVEYS AND AERIAL SURVEYS, PLAN DIMENSIONS AND DETAILS RELATIVE TO THE EXISTING FACILITIES HAVE BEEN TAKEN FROM EXISTING PLANS AND ARE SUBJECT TO CONSTRUCTION VARIATIONS. IT SHALL BE THE RESPONSIBILITY OF THE CONTRACTOR TO VERIFY SUCH DIMENSIONS AND DETAILS IN THE FIELD. SUCH VARIATIONS SHALL NOT BE A CAUSE FOR ADDITIONAL COMPENSATION DUE TO A CHANGE IN THE SCOPE OF WORK. HOWEVER, THE CONTRACTOR WILL BE PAID FOR THE QUANTITY ACTUALLY FURNISHED AT THE UNIT PRICE BID FOR THE WORK.
7. PRIOR TO THE STRIPING OF NO PASSING ZONES, THE BUREAU OF OPERATIONS SHALL BE NOTIFIED 14 DAYS IN ADVANCE TO FIELD VERIFY SUCH PROPOSED MARKINGS. THE DISTRICT 6 SIGN SHOP CAN BE REACHED AT (217) 785-0288.
8. ALL REFERENCES IN THE PLANS TO "BITUMINOUS" SHALL BE INTERPRETED TO MEAN "HOT-MIX ASPHALT."
9. LEVELING BINDER QUANTITIES INCLUDE QUANTITIES TO CORRECT SUPERELEVATIONS THROUGH ALL 3 CURVES. SEE THE DETAIL ON SHEET 9 FOR CURVE 2 CORRECTIONS. CURVES 1 & 3 REQUIRE THE EXISTING SUPERELEVATED PAVEMENT TO BE PLACED BACK AT NORMAL CROWN. THE CONTRACTOR AND ENGINEER SHALL VERIFY THAT THIS CAN BE DONE BY MILLING THE EXISTING PAVEMENT AT NORMAL CROWN. IN THE EVENT THAT THE MILLING CANNOT CORRECT THE PAVEMENT SLOPE WITHOUT COMPROMISING THE INTEGRITY OF THE EXISTING PAVEMENT, THE LOW SIDE OF THE PAVEMENT SHALL BE BUILT UP WITH LEVELING BINDER UNTIL NORMAL CROWN CAN BE ACHIEVED. THE COST TO MILL THE CORRECTED SUPERELEVATIONS SHALL BE INCLUDED WITH THE HMA SURFACE REMOVAL (VARIABLE DEPTH) COST.

COMMITMENTS

1. FIELD/RESIDENT ENGINEER SHALL CONTACT STUDIES AND PLANS CONCERNING ANY MAJOR PLAN CHANGES TO MAKE SURE NO PREVIOUS COMMITMENTS (NOT LISTED) WERE MADE AFFECTING THE DESIGN AND ALLOW AN IMPROVED DESIGN FOR FUTURE PROJECTS.

APPLICATION RATES

SEEDING FERTILIZER NUTRIENTS (NIT:PHOS:POT)	90: 90: 90 lbs./acre
MULCH RATE	2.0 tons/acre
AGRICULTURAL GROUND LIMESTONE	2.0 tons/acre
AGGREGATE ITEMS	2.05 tons/cu. yd.
STONE DUMPED RIPRAP	1.75 tons/cu. yd.
HMA MATERIALS (PRIME COAT) ON HMA BASE	0.00038 tons/sq. yd.
HMA MATERIALS (PRIME COAT) ON AGG. BASE	0.001425 tons/sq. yd.
AGGREGATE (PRIME COAT)	0.002 tons/sq. yd.
LEVELING BINDER	112 lbs/sq. yd. Inch
HMA CONCRETE SURFACE COURSE	112 lbs/sq. yd. inch
HMA SHOULDER	112 lbs/sq. yd. Inch
INCIDENTAL HMA	112 lbs/sq. yd. inch

MIXTURE REQUIREMENTS

MIXTURE USE(S):	LEVELING BINDER	HMA SURF CSE	INCIDENTAL HMA SURF
AC/PG	PG 64-22	PG 64-22	PG 64-22
DESIGN AIR VOIDS	4.0 % N DESIGN = 50	4.0% % N DESIGN = 50	4.0% % N DESIGN = 50
MIXTURE COMPOSITION (GRADATION MIXTURE)	IL 9.5	IL 9.5 OR IL 12.5	IL 9.5 OR 12.5
VOLUMETRIC REQ'S	-	-	-
FRICTION AGGREGATE	NA	MIXTURE "C"	MIX C

DISTRICT SIX	
EXAMINED	Jan 13 20 09
<i>[Signature]</i>	
OPERATIONS ENGINEER	
EXAMINED	Jan 21 20 09
<i>[Signature]</i>	
PROGRAM IMPLEMENTATION ENGINEER	
EXAMINED	Jan 21 20 09
<i>[Signature]</i>	
PROGRAM DEVELOPMENT ENGINEER	

REVISIONS		ILLINOIS DEPARTMENT OF TRANSPORTATION
NAME	DATE	
		GENERAL NOTES

SCALE: VERT. _____
 DATE _____

DRAWN BY _____
 CHECKED BY _____

F.A.P. RTE.	SECTION	COUNTY	TOTAL SHEETS	SHEET NO.
71	*	LOGAN	14	3
STA.		TO STA.		
FED. ROAD DIST. NO.	ILLINOIS	FED. AID PROJECT		
• 10(RS-2) 11(RS-2)				

ILLINOIS DEPARTMENT OF TRANSPORTATION

SUMMARY OF QUANTITIES

LOCATION OF WORK				CONSTRUCTION TYPE CODE		
SUMMARY OF QUANTITIES				100% FED		
CODE NO.	ITEM	UNIT	TOTAL QUANTITY	ROADWAY 1000		
35800100	PREPARATION OF BASE	SQ YD	75	75		
40200800	AGGREGATE SURFACE COURSE, TYPE B	TON	20	20		
40600200	BITUMINOUS MATERIALS (PRIME COAT)	TON	42.6	42.6		
40600300	AGGREGATE (PRIME COAT)	TON	216	216		
40600625	LEVELING BINDER (MACHINE METHOD), N50	TON	5,030	5,030		
40600895	CONSTRUCTING TEST STRIP	EACH	1	1		
40600982	HOT-MIX ASPHALT SURFACE REMOVAL - BUTT JOINT	SQ YD	1,543	1,543		
40600990	TEMPORARY RAMP	SQ YD	29	29		
40603310	HOT-MIX ASPHALT SURFACE COURSE, MIX "C", N50	TON	8,931	8,931		
40800050	INCIDENTAL HOT-MIX ASPHALT SURFACING	TON	211	211		
44000198	HOT-MIX ASPHALT SURFACE REMOVAL, VARIABLE DEPTH	SQ YD	106,232	106,232		
44200168	PAVEMENT PATCHING, TYPE II, 14 INCH	SQ YD	1,200	1,200		
44200172	PAVEMENT PATCHING, TYPE III, 14 INCH	SQ YD	500	500		
44200174	PAVEMENT PATCHING, TYPE IV, 14 INCH	SQ YD	500	500		

REVISIONS	
NAME	DATE

ILLINOIS DEPARTMENT OF TRANSPORTATION

SUMMARY OF QUANTITIES

SCALE: VERT.
HORIZ.
DATE

DRAWN BY
CHECKED BY

F.A.P. RTE.	SECTION	COUNTY	TOTAL SHEETS	SHEET NO.
71		LOGAN	14	5
STA.	TO STA.			
FED. ROAD DIST. NO.	ILLINOIS	FED. AID PROJECT		
• 10(RS-2); 11(RS-2)				

SCHEDULE OF QUANTITIES

SURFACE AREA CALCULATIONS						QUANTITY CALCULATIONS						
STATION BEGIN	TO	STATION END	DISTANCE (FT)	AVG PAVEMENT WIDTH (FT)	PAVEMENT (SQ FT)	BIT SURF REM (VAR DEPTH) (SQ YD)	BIT SURF REMOVAL BUTT JOINT (SQ YD)	TEMP RAMP (SQ YD)	LEVELING BINDER (MACHINE METHOD) SUPERPAVE N50 (TON)	BIT MAT (PRIME COAT) (TON)	AGGREGATE (PRIME COAT) (TON)	BIT CONC SURF CSE, SUPERPAVE MIX "C" N50 (TON)
82+38.50		82+53.50	15.00	26	390.00		43.3	14.44	---	0.02	0.09	3.64
82+53.50		118+26.00	3,572.50	26	92,885.00	10,320.6	---	---	431.6 *	3.92	20.64	866.93
94+57.27		106+12.83	1,155.56	26	15,022.28	---	---	---	290 **	---	---	---
118+28.90		450+29.00	33,200.1	26	863,202.6	95,911.4	---	---	4,026.5 *	36.45	191.82	8,056.56
450+29.00		450+44.00	15.00	26	390.00	---	43.3	14.44	---	0.02	0.09	3.64
CURVE 1 & CURVE 3 ENTRANCE SCHEDULE						---	1456.3	---	282 ***	---	---	---
TOTALS						106,232.0	1542.9	28.89	5030.1	42.57	215.88	8,930.77
USE						106,232	1543	29	5030	42.6	216	8,931

NOTE: * SEE BUTT-JOINT DETAIL FOR LIMITS
 ** ADDITIONAL LEVEL BINDER ESTIMATED TO INCREASE SE
 *** ADDITIONAL LEVEL BINDER ESTIMATED TO CORRECT SUPERELEVATION TO NORMAL CROWN

PAVEMENT MARKING SCHEDULE							
STA.	TO	STA.	LT/RT	SHORT-TERM PAVT MRKNG (FOOT)	TEMP PAVT MARKING LINE 5" (FOOT)	WORK ZONE PAVT MRKNG REMOVAL (SQ FT)	PAINT PAVT MARKING LINE 5" (FOOT)
EDGE LINES							
[R 1]							
82+38.50		118+26.00	LT	---	3,587.5	---	3,587.5
82+38.50		118+26.00	RT	---	3,587.5	---	3,587.5
[R 2]							
118+28.90		450+44.00	LT	---	33,215.1	---	33,215.1
118+28.90		450+44.00	RT	---	33,215.1	---	33,215.1
CENTER LINES / NO PASSING							
[R 1]							
82+38.50		118+26.00		1077	1,397.0	119.7	1,397.0
[R 2]							
118+28.90		450+44.00		9,966	8,804.0	1,107.3	8,804.0
TOTALS				11,043	83,806.2	1,227.0	83,806.2
USE				11,043	83,806	1,227	83,806

RAISED REFLECTIVE PAVEMENT MARKER SCHEDULE							
STA.	TO	STA.	DISTANCE	SPACING	RAISED REFL PAVEMENT MARKER (EACH)	RAISED REFL PAVEMENT MARKER REM (EACH)	
[R 1]							
82+38.50		118+26.00	3,587.5	80	45	45	
[R 2]							
118+28.90		450+44.00	33,215.1	80	415	415	
TOTALS					460	460	
USE					460	460	

AGGREGATE SHOULDER SCHEDULE					
STATION BEGIN	TO	STATION END	LT/RT	DISTANCE (FT)	AGG SHLD TY B (TON)
[R 1]					
82+38.5		118+26.0	LT	3,587.5	136.2
82+38.5		118+26.0	RT	3,587.5	136.2
[R 2]					
118+28.9		450+44.0	LT	33,215.1	1260.9
118+28.9		450+44.0	RT	33,215.1	1260.9
TOTALS					2794.2
USE					2794

REVISIONS		ILLINOIS DEPARTMENT OF TRANSPORTATION
NAME	DATE	
		SCHEDULE OF QUANTITIES

SCALE: VERT. DRAWN BY
 HORIZ. CHECKED BY
 DATE

F.A.P. RTE.	SECTION	COUNTY	TOTAL SHEETS	SHEET NO.
71	•	LOGAN	14	6
STA.		TO STA.		
FED. ROAD DIST. NO.	ILLINOIS	FED. AID PROJECT		

• 10(RS-2); 11(RS-2)

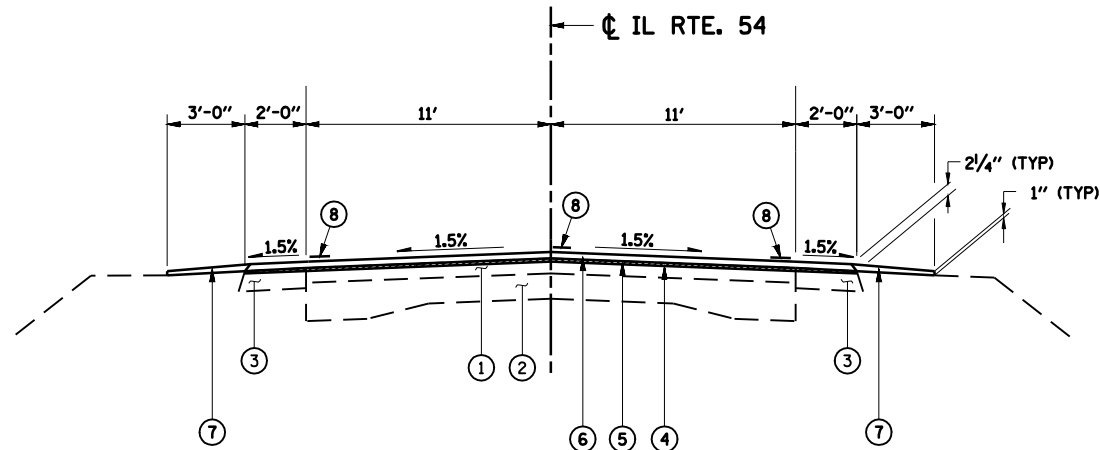

TYPICAL SECTION

STA. 83+05.72 TO STA. 94+57.27 [R1]
 STA. 106+12.83 TO STA. 450+44 [R1]

LEGEND

- ① EX BITUMINOUS CONCRETE SURFACE COURSE 5" ±
- ② EX PCC PAVEMENT (9-7-9) W/REINFORCEMENT MESH
- ③ EX BITUMINOUS CONCRETE SHOULDER, 8"
- ④ PR HMA SURFACE REMOVAL (VARIABLE DEPTH 3/4" AVG @ ϕ)
- ⑤ PR LEVELING BINDER (MACHINE METHOD), N50 (3/4" & VARIES)
- ⑥ PR BIT CONC SURFACE CSE, SUPERPAVE, MIX "C", N50 (1 1/2")
- ⑦ PR AGGREGATE SHOULDERS, TYPE B
- ⑧ PR PAVEMENT MARKING - LINE 5"

NOTE:
 SEE "SUPERELEVATION TRANSITION DETAILS" FOR S.E. TABLE.

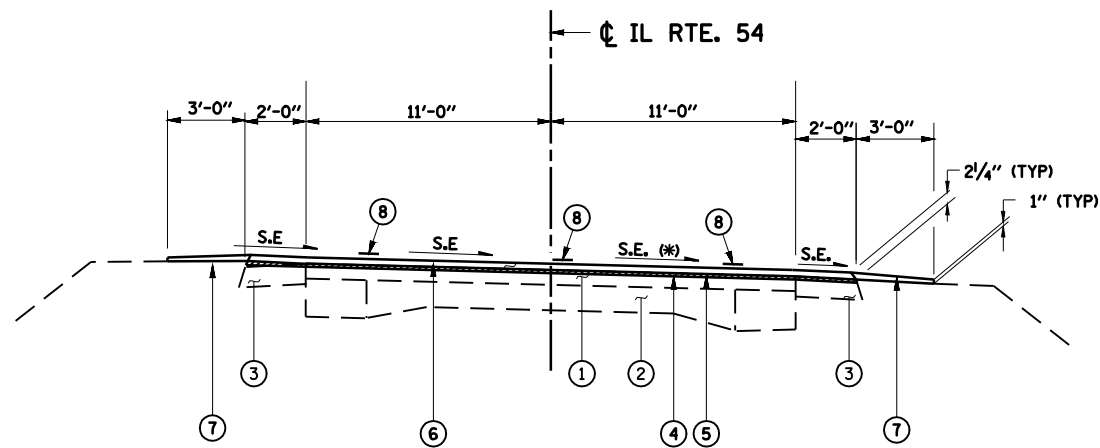

TYPICAL SECTION

STA. 82+38.50 TO STA. 83+05.72 - FULL SE TO NORMAL CROWN
 STA. 94+57.27 TO STA. 95+57.37 - SE TRANS.
 STA. 95+57.37 TO STA. 105+12.73 - FULL SE = -2.60% LT
 STA. 105+12.73 TO STA. 106+12.83 - SE TRANS.

NOTE: STA EQU 118+26.00 (BK) = 118+28.90 (AH)

REVISIONS	
NAME	DATE

ILLINOIS DEPARTMENT OF TRANSPORTATION

TYPICAL SECTIONS

SCALE: VERT. _____
 HORIZ. _____
 DATE _____ DRAWN BY _____
 CHECKED BY _____

F.A.P. RTE.	SECTION	COUNTY	TOTAL SHEETS	SHEET NO.
71		LOGAN	14	7
STA.		TO STA.		
FED. ROAD DIST. NO.	ILLINOIS	FED. AID PROJECT		

• 10(RS-2); 11(RS-2)

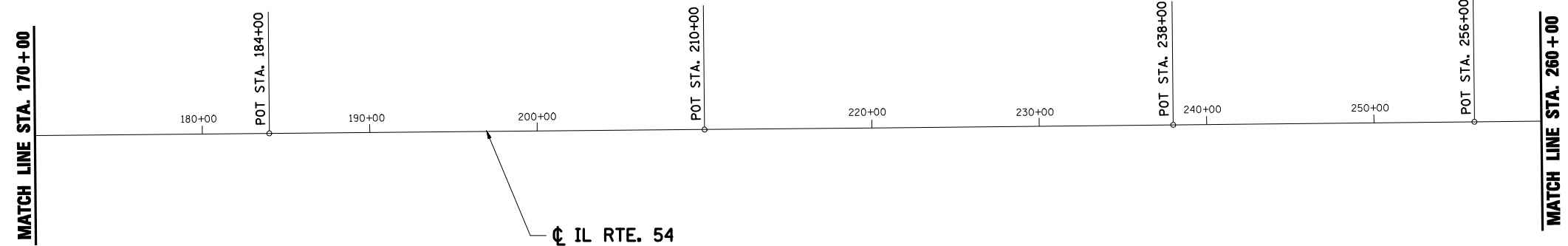
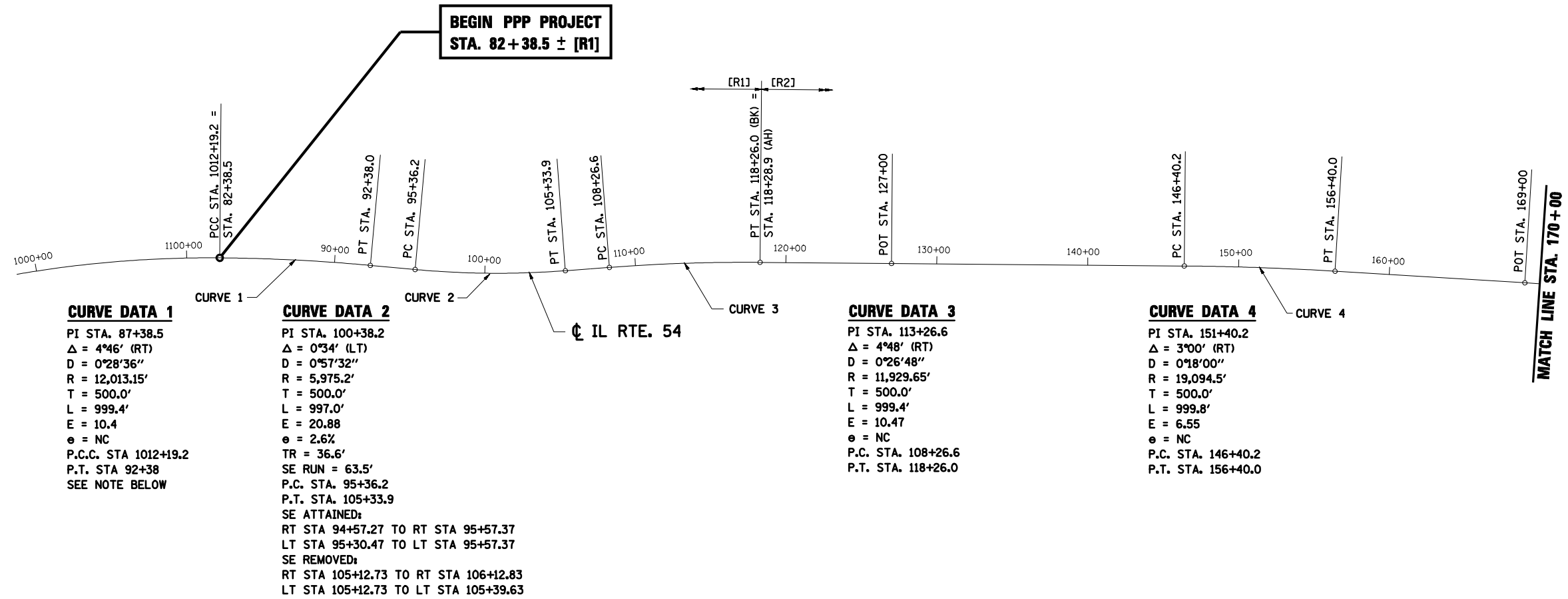

NOTE: CURVE 1 REQUIRES NO SUPERELEVATION. CONTRACTOR SHALL MATCH EXISTING SUPERELEVATION AT STATION 82+38.5 AND TRANSITION TO NORMAL CROWN AT STATION 83+05.72

REVISIONS	
NAME	DATE

ILLINOIS DEPARTMENT OF TRANSPORTATION

ALIGNMENTS

SCALE: VERT. 1"=40'
 HORIZ. 1"=100'
 DATE: CMS DRAWN BY: CHECKED BY:

F.A.P. RTE.	SECTION	COUNTY	TOTAL SHEETS	SHEET NO.
71	•	LOGAN	14	8
STA.		TO STA.		
FED. ROAD DIST. NO.	ILLINOIS	FED. AID PROJECT		
• 10(RS-2); 11(RS-2)				

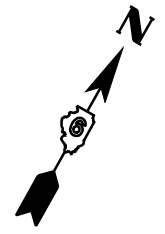
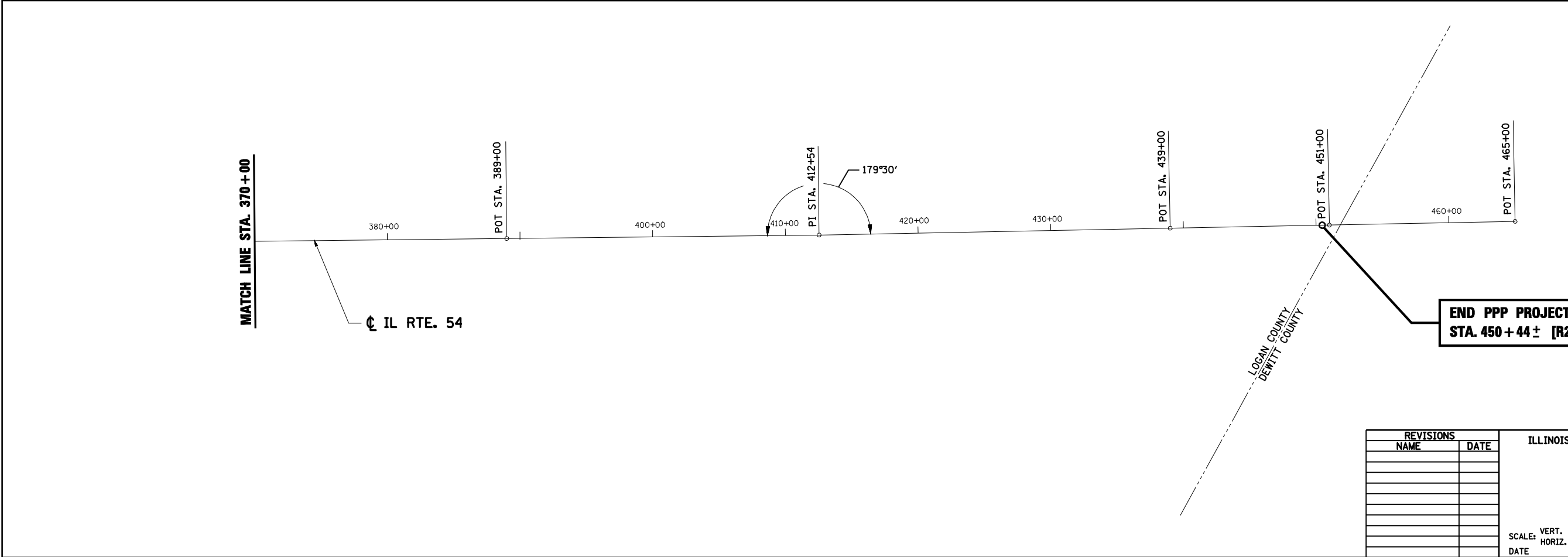
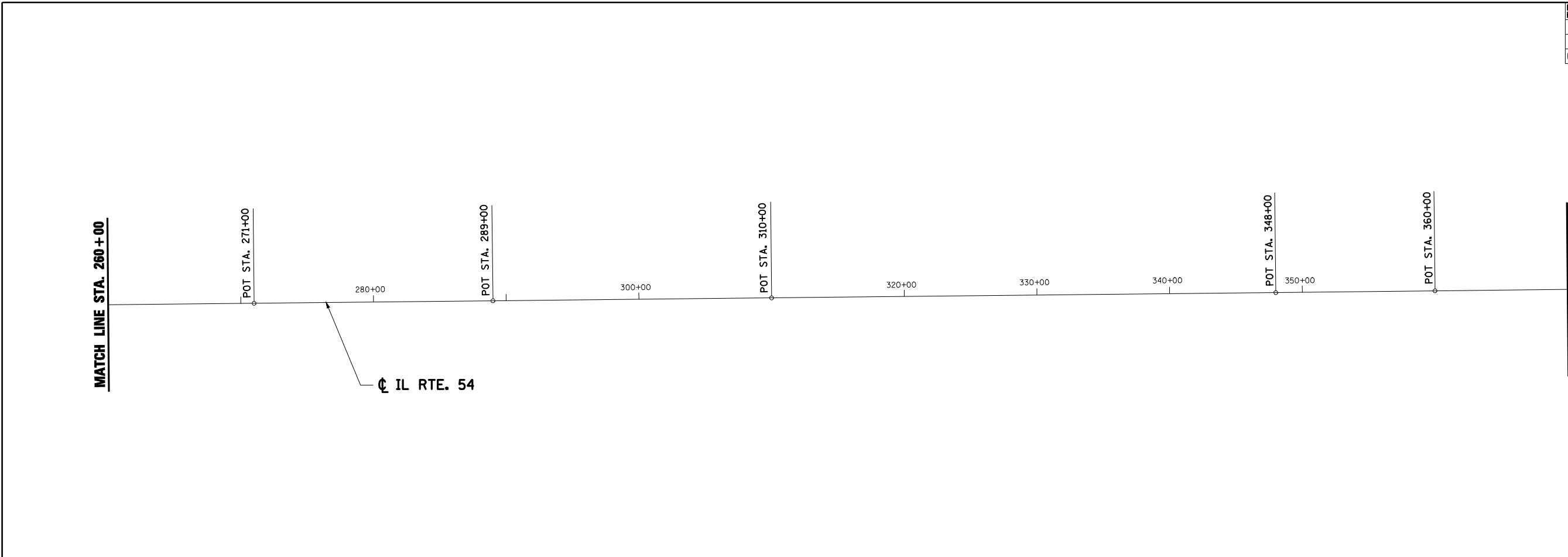
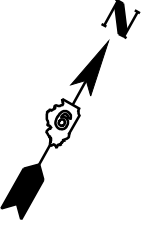

REVISIONS	
NAME	DATE

ILLINOIS DEPARTMENT OF TRANSPORTATION

ALIGNMENTS

SCALE: VERT. _____
 HORIZ. _____

DATE _____

DRAWN BY _____
 CHECKED BY _____

F.A.P. RTE.	SECTION	COUNTY	TOTAL SHEETS	SHEET NO.
71	•	LOGAN	14	9
STA.		TO STA.		
FED. ROAD DIST. NO.	ILLINOIS	FED. AID PROJECT		
• 10(RS-2); 11(RS-2)				

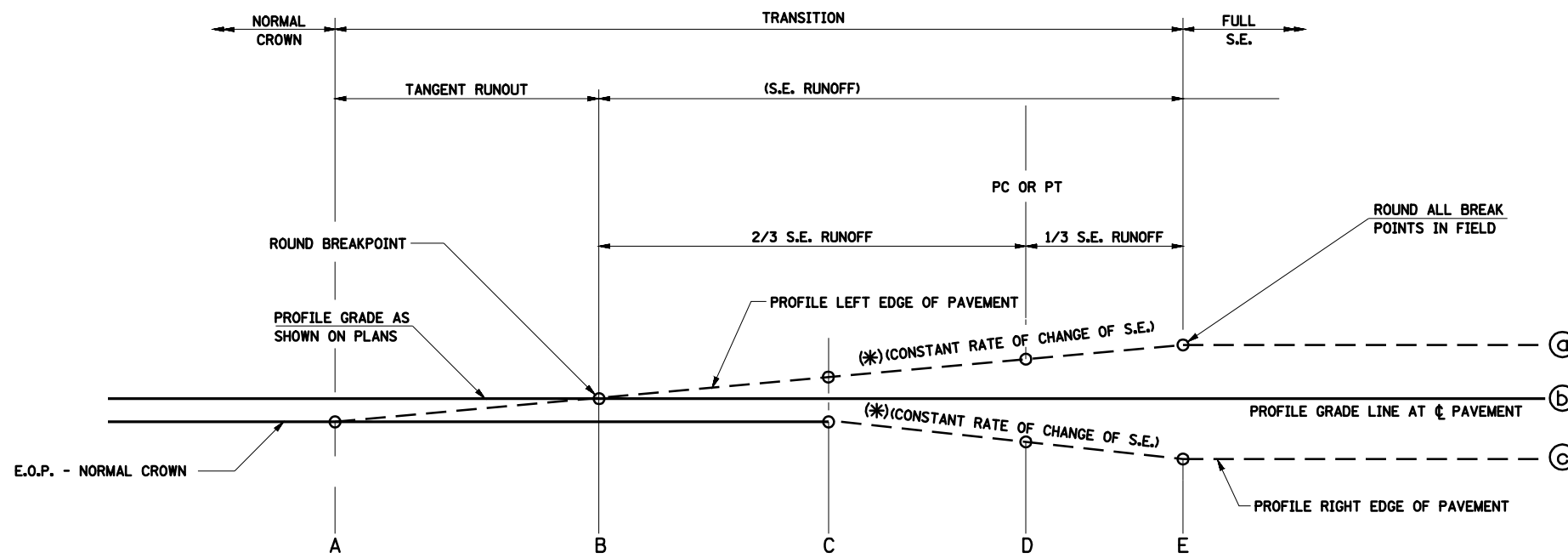

(*) RATE	
CURVE 2 - [R1]	0.041

TYPICAL PROFILE - S.E. TRANSITION

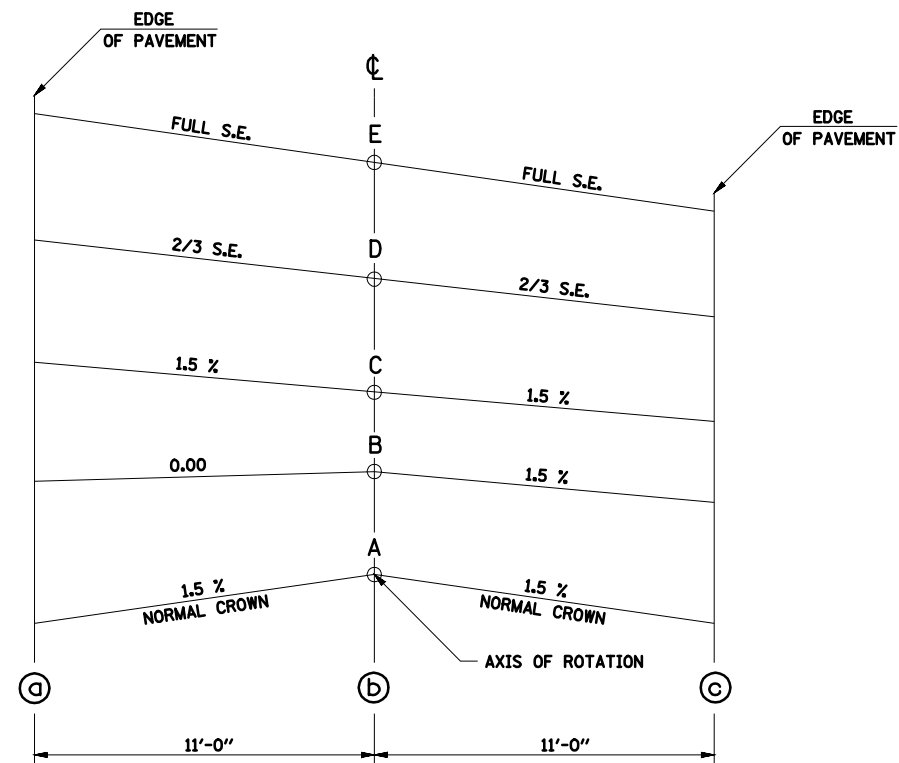

TYPICAL CROSS SECTION - S.E. TRANSITION

LOCATION OF SUPERELEVATION TRANSITIONS (STA.)										
CURVE	EX. S.E.	REQ'D SE	TR	L ₁	S _{normal}	A	B	C	D	E
2 - [R1]	1.25%	2.6%	36.6'	63.5'	1.5%	94+57.27	94+93.87	---	PC 95+36.2	95+57.37
						106+12.83	105+76.23	---	PT 105+33.9	105+12.73

$$TR = \frac{S_{normal}}{S.E.} (L_1)$$

$$L_1 = (S.E.) \cdot (w) \cdot (RS)$$

L₁ = CALCULATED SUPERELEVATION RUNOFF LENGTH

w = WIDTH OF ROTATION FOR ONE LANE

S_{normal} = TRAVEL LANE CROSS SLOPE ON TANGENT, DECIMAL

RS = RECIPROCAL OF RELATIVE LONGITUDINAL SLOPE BETWEEN THE P.G.L. AND OUTSIDE EDGE (1/(*)) RATE

REVISIONS	
NAME	DATE

ILLINOIS DEPARTMENT OF TRANSPORTATION

SUPERELEVATION TRANSITION DETAILS

SCALE: VERT.
HORIZ.

DRAWN BY
CHECKED BY

F.A.P. RTE.	SECTION	COUNTY	TOTAL SHEETS	SHEET NO.
71	•	LOGAN	14	10
STA.		TO STA.		
FED. ROAD DIST. NO.	ILLINOIS	FED. AID PROJECT		
• 10(RS-2); 11(RS-2)				

RAMP LOCATIONS			
	(A)	(B)	(C)
DESCRIPTION	BEGIN STATION	PAY LIMITS	END STATION
BEGIN IMPROVEMENT	82+38.5	82+53.5	82+68.5
END IMPROVEMENT	450+44	450+29	450+14

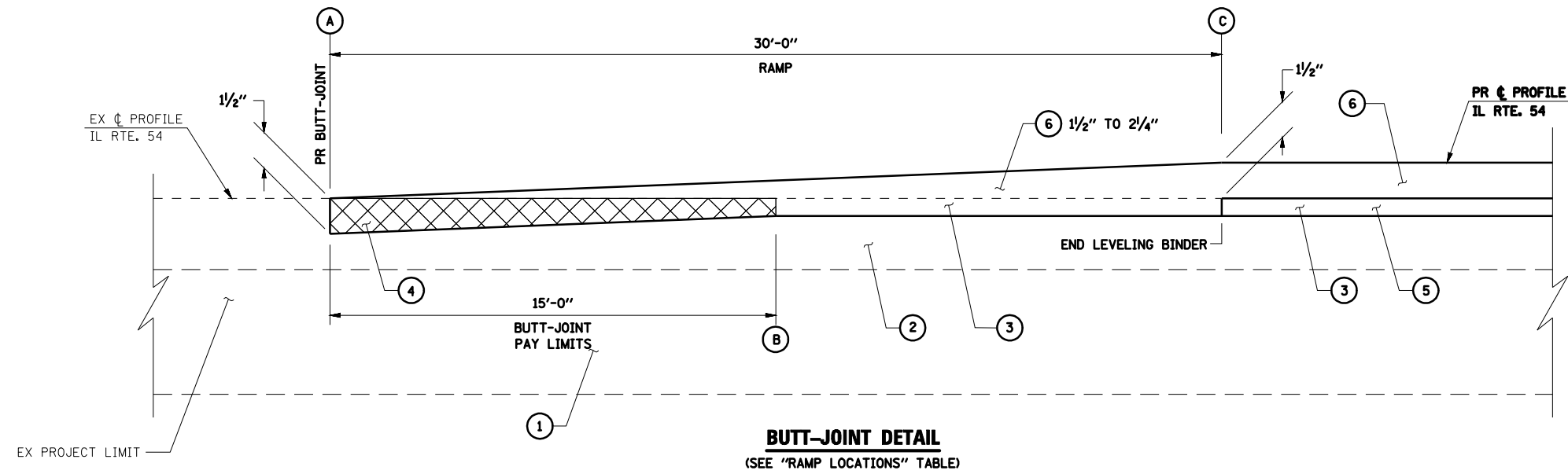

LEGEND

- ① EX PCC PAVEMENT (9-7-9)
- ② EX HMA CONCRETE SURFACE COURSE
- ③ PR HMA SURFACE REMOVAL (VARIABLE DEPTH 3/4" AVG @ C)
- ④ PR HMA SURFACE REMOVAL BUTT-JOINT
- ⑤ PR LEVELING BINDER (MACHINE METHOD), SUPERPAVE N50 (3/4")
- ⑥ PR BIT CONC SURFACE CSE, SUPERPAVE, MIX "C", N50 (1 1/2")

BUTT-JOINT DETAIL
(SEE "RAMP LOCATIONS" TABLE)

REVISIONS	
NAME	DATE

ILLINOIS DEPARTMENT OF TRANSPORTATION

BUTT-JOINT DETAILS

SCALE: VERT. _____
HORIZ. _____

DRAWN BY _____
CHECKED BY _____

F.A.P. RTE.	SECTION	COUNTY	TOTAL SHEETS	SHEET NO.
71	•	LOGAN	14	11
STA.		TO STA.		
FED. ROAD DIST. NO.	ILLINOIS	FED. AID PROJECT		

• 10(RS-2); 11(RS-2)

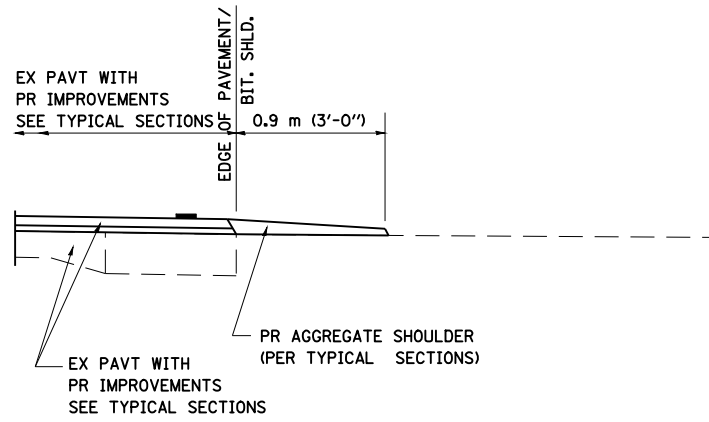

SECTION A-A FOR EX EARTH / AGGREGATE FE

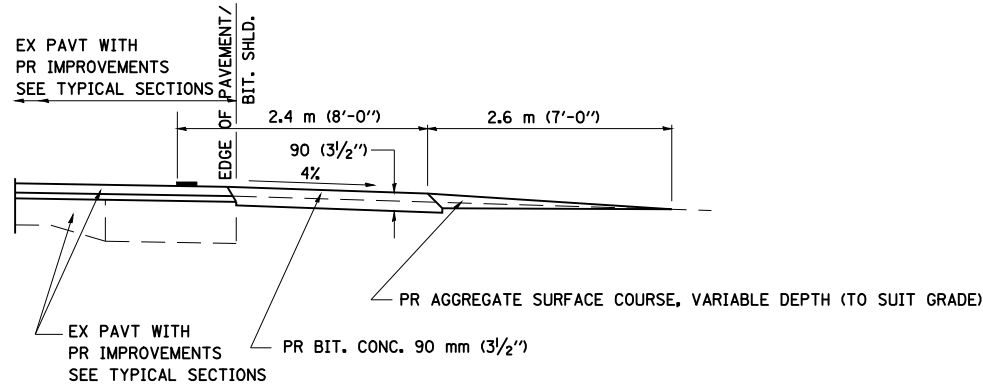

SECTION A-A FOR EX EARTH / AGGREGATE PE

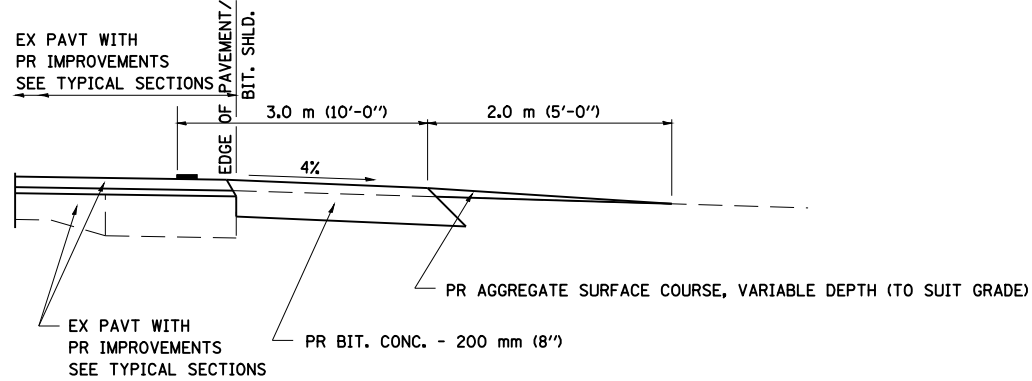

SECTION A-A FOR EX EARTH / AGGREGATE CE & SIDE ROAD

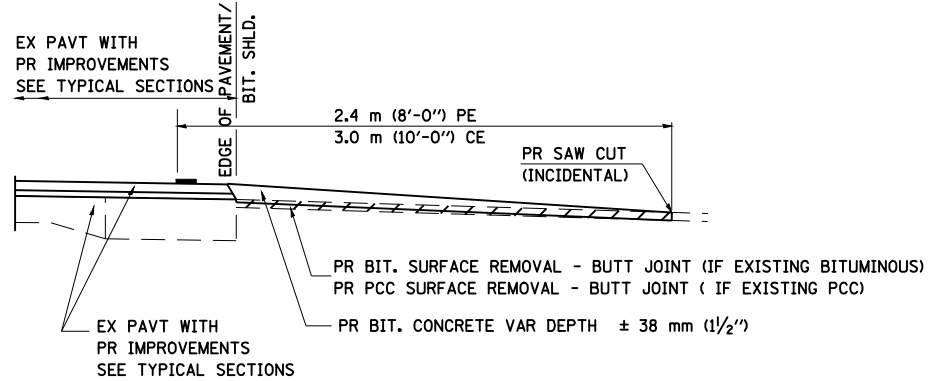

SECTION A-A FOR EX BITUMINOUS / PC CONCRETE PE, CE & SIDE ROAD

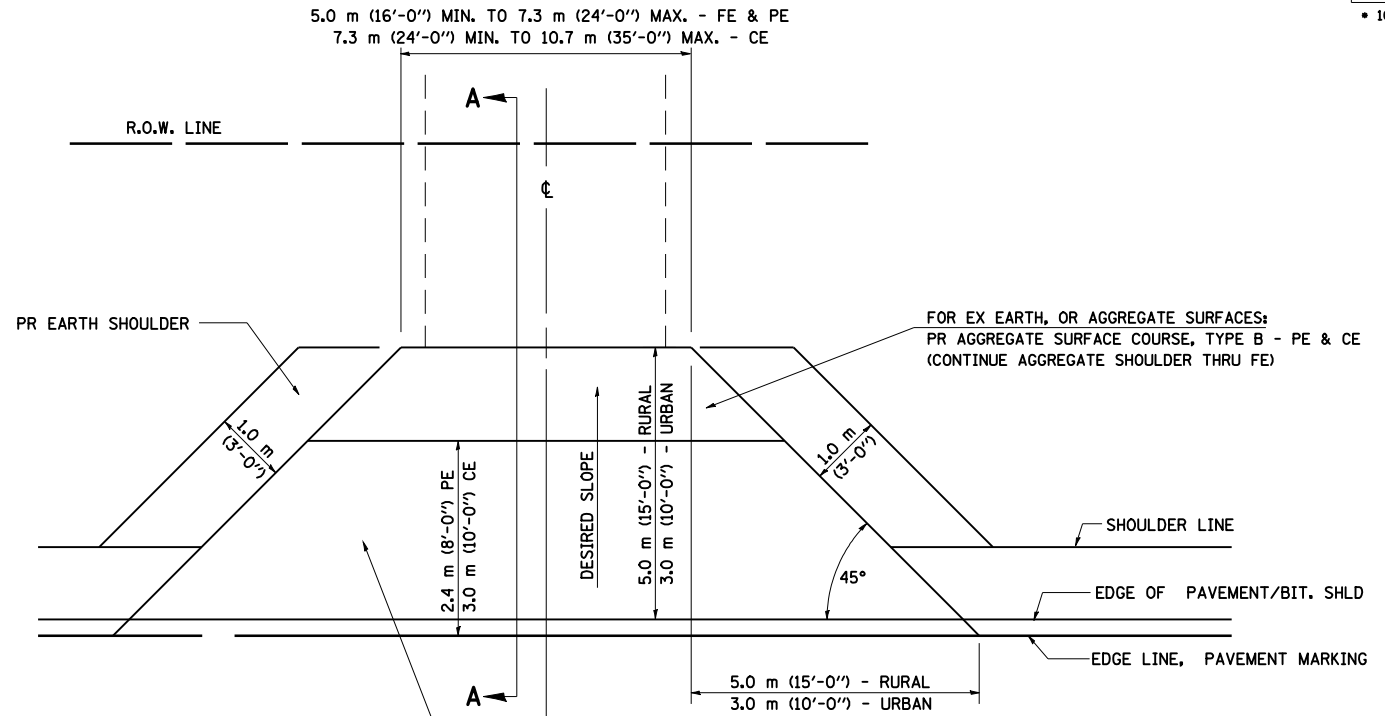

FOR EX EARTH OR AGGREGATE SURFACES:
 PR BIT SURFACE REMOVAL (IF APPLICABLE)
 PR AGGREGATE SHOULDER THRU - FE
 PR BITUMINOUS CONCRETE 90 mm (3 1/2") - PE
 PR BITUMINOUS CONCRETE 200mm (8") - CE

FOR EX BITUMINOUS CONCRETE SURFACES:
 PR BITUMINOUS SURFACE REMOVAL-BUTT JOINT

FOR EX PCC SURFACES:
 PR PCC SURFACE REMOVAL-BUTT JOINT

GENERAL NOTES:

THE RESIDENT ENGINEER WILL DETERMINE THE EXACT TYPE OF IMPROVEMENT TO BE COMPLETED FOR ALL ENTRANCES, SIDEROADS AND MAILBOX TURNOUTS ON THIS PROJECT.

THE PLAN DETAILS AND SCHEDULES SHOULD BE USED AS A GUIDE FOR THE ENGINEER TO IMPLEMENT THE FINAL DESIGN. THE ENGINEER MAY DECIDE TO SALVAGE PORTIONS OF THE EXISTING ENTRANCE PAVEMENT STRUCTURE; THEREFORE, REDUCING PAY ITEM QUANTITIES. NO ADDITIONAL PAYMENT WILL BE ALLOWED FOR THIS REDUCTION IN QUANTITIES.

ANY WORK THE ENGINEER REQUIRES WHICH IS NOT COVERED BY A PAY ITEM CONTAINED IN THE PLANS WILL BE PAID FOR IN ACCORDANCE WITH ARTICLE 109.04 OF THE STANDARD SPECIFICATIONS.

BITUMINOUS CONCRETE REQUIRED TO CONSTRUCT THE ENTRANCES SHALL BE IN ACCORDANCE WITH THE APPLICABLE PORTIONS OF SECTION 406 AND 408 OF THE STANDARD SPECIFICATIONS AND AS DIRECTED BY THE ENGINEER.

WHEN THE BITUMINOUS CONCRETE PROPOSED FOR THE IMPROVEMENT IS THICKER THAN 75 mm (3 INCHES) AND REQUIRE PLACEMENT IN MORE THAN ONE LIFT. THE BOTTOM LIFT(S) SHALL MEET THE REQUIREMENTS OF BITUMINOUS BASE COURSE IN SECTION 406 OF THE STANDARD SPECIFICATIONS AND THE TOP LIFT OF 50 mm (2 INCHES) SHALL MEET THE REQUIREMENTS OF BITUMINOUS CONCRETE SURFACE COURSE, SUPERPAVE.

THIS WORK WILL BE PAID FOR IN ACCORDANCE WITH SECTIONS 351, 358, 408, 423 AND 440 OF THE STANDARD SPECIFICATIONS.

ALL DIMENSIONS ARE IN MILLIMETERS (INCHES) UNLESS OTHERWISE SHOWN.

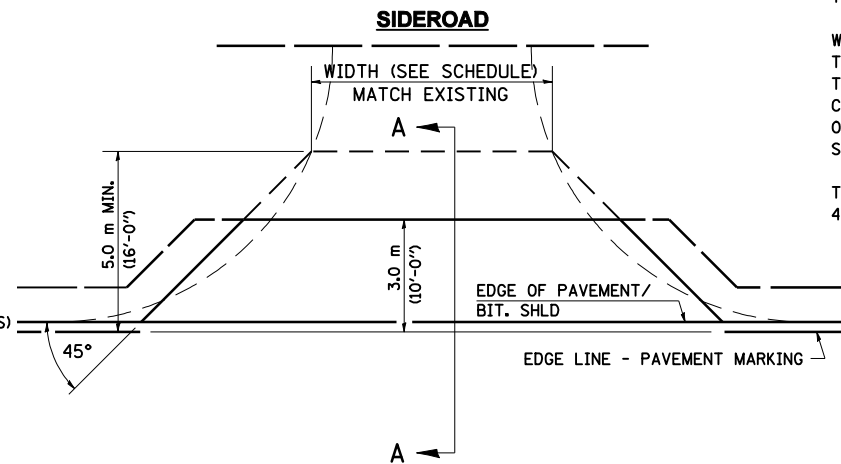

NOTE : IF BIT. SHLDS ARE PROPOSED THEY SHOULD NOT EXTEND THROUGH SIDEROADS

REVISIONS	
NAME	DATE
JCN	2/19/03

SHEET 1 OF 4
 ILLINOIS DEPARTMENT OF TRANSPORTATION
DISTRICT SIX
DETAILS FOR RURAL / URBAN
ENTRANCE, MAILBOX TURNOUT
& SIDEROADS
W / O CONCRETE GUTTER
(PPP - PROJECTS)

SCALE: VERT. DATE: FEBRUARY 23, 1999
 HORIZ. DRAWN BY CADD
 CHECKED BY JCN

F.A.P. RTE.	SECTION	COUNTY	TOTAL SHEETS	SHEET NO.
71	•	LOGAN	14	12
STA.		TO STA.		
FED. ROAD DIST. NO.	ILLINOIS	FED. AID PROJECT		
• 10(RS-2); 11(RS-2)				

DETAILS OF MAILBOX TURNOUTS

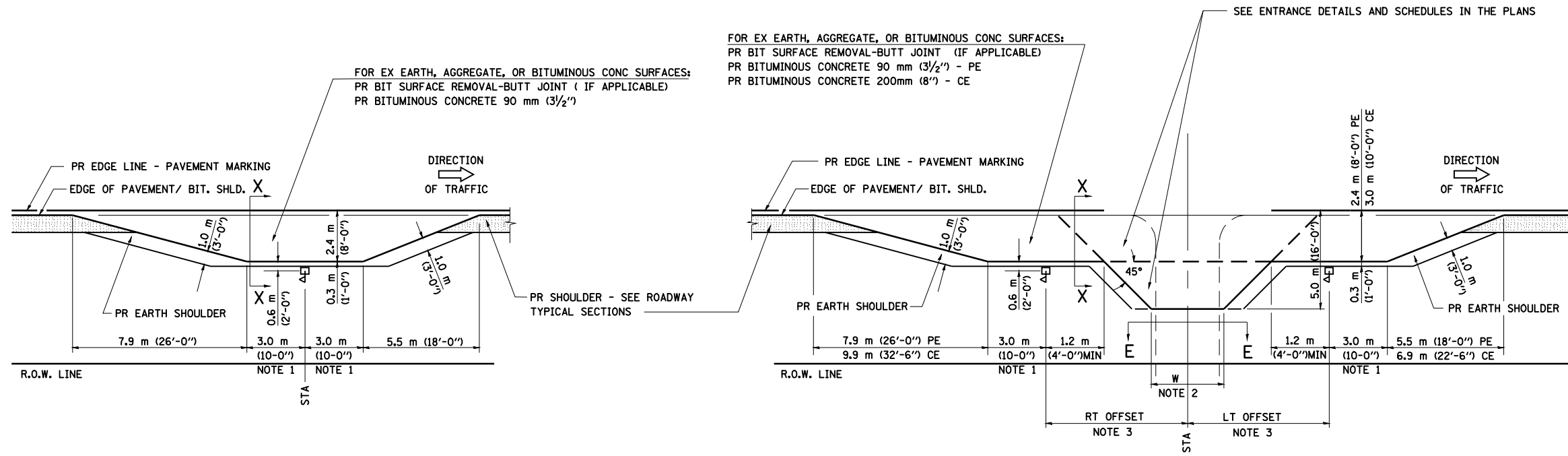

PLAN - MAILBOX TURNOUTS

PLAN - COMBINED MAILBOX TURNOUT WITH TRAILING OR LEADING ENTRANCE

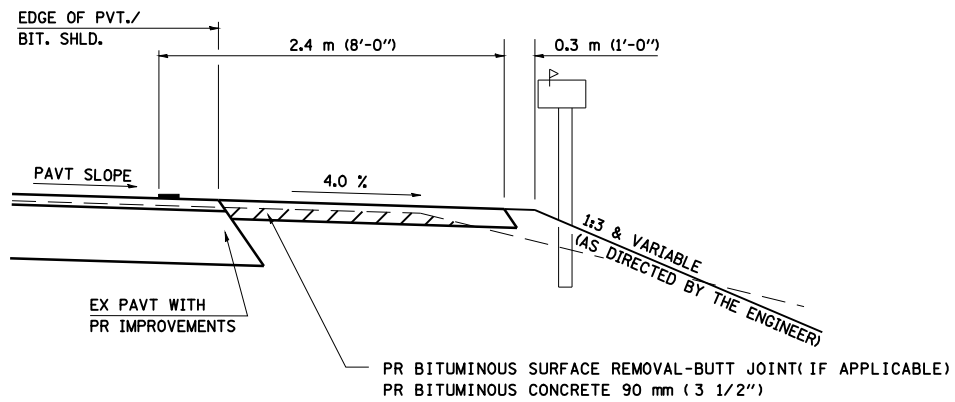

SECTION X-X THRU MAILBOX TURNOUT
 ALSO APPLIES TO MAILBOX TURNOUTS COMBINED WITH
 EX EARTH, AGGREGATE, OR BITUMINOUS PE & FE

(DETAIL APPLIES WHEN M.B. TURNOUT DOES NOT EXIST.
 IF EXISTING, TREAT SAME AS ENTRANCE.)

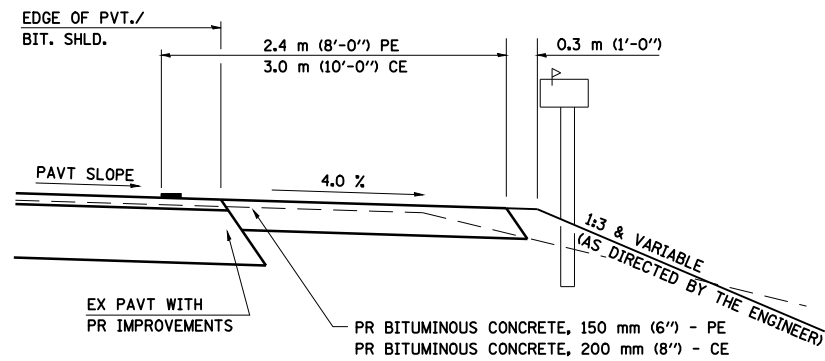

SECTION X-X THRU MAILBOX TURNOUT
 COMBINED WITH EX BITUMINOUS CONC & PC CONC PE & CE

(DETAIL APPLIES WHEN M.B. TURNOUT DOES NOT EXIST.
 IF EXISTING, TREAT SAME AS ENTRANCE.)

- NOTE 1 IF MORE THAN ONE MAILBOX IS PRESENT, DIMENSION FROM CENTER OF END MAILBOX.
- NOTE 2 FOR ENTRANCE LAYOUT DIMENSIONS AND SECTIONS A-A & E-E REFER TO THE SCHEDULES IN THE PLANS.
- NOTE 3 BOTH LT OR RT OFFSETS FOR MAILBOX SHOWN USE OFFSET DIMENSION PER SCHEDULE AND REFER TO LAYOUT SHOWN ON THE PLAN.

ALL DIMENSIONS ARE IN MILLIMETERS (INCHES)
 UNLESS OTHERWISE SHOWN.

SHEET 2 OF 4

REVISIONS	
NAME	DATE
JCN	2/19/03

ILLINOIS DEPARTMENT OF TRANSPORTATION
 DISTRICT SIX
 DETAILS FOR RURAL / URBAN
 ENTRANCE, MAILBOX TURNOUT
 & SIDEROADS
 W / O CONCRETE GUTTER
 (PPP - PROJECTS)

SCALE: VERT. DRAWN BY CADD
 HORIZ. CHECKED BY JCN
 DATE: FEBRUARY 23, 1999

F.A.P. RTE.	SECTION	COUNTY	TOTAL SHEETS	SHEET NO.
71	•	LOGAN	14	13
STA.		TO STA.		
FED. ROAD DIST. NO.	ILLINOIS	FED. AID PROJECT		
• 10(RS-2); 11(RS-2)				

ENTRANCE IMPROVEMENT SCHEDULE FOR RURAL / URBAN "PPP" PROJECTS

LOCATION (LT / RT) (STA) (+)	TYPE OF ENTRANCE (FE / PE / CE / MB) (RURAL / URBAN)	MATERIAL TYPE (EX / PR)	WIDTH AT EDGE OF PAVT FOOT	RT OFFSET FOOT	LT OFFSET FOOT	LENGTH (FROM EDGE OF PVT/ BIT SHLD TO LIMITS OF IMPROVEMENT) FOOT	PR BIT. CONC. AVERAGE THICKNESS INCH	BIT. SURF. REM. - BUTT JOINT SQ. YD.	P. C. C. SURF. REM. - BUTT JOINT SQ. YD.	PREP OF BASE SQ. YD.	AGG. BASE REPAIR TON	AGGREGATE SURFACE COURSE TY - B TON	BIT (P. C.) TON	AGG (P. C.) TON	INCIDENTAL BIT. SURF. SUPERPAVE TON
LT STA. 87+90	SR (700 ST)	O&C/BIT	141			10	2	109.3					0.16	0.22	12.2
RT STA. 88+07	SR (700 ST)	O&C/BIT	126			10	2	98.2					0.14	0.20	11.0
RT STA. 96+79	SR (1800 AV)	O&C/BIT	62			10	2	44.9					0.06	0.09	5.0
LT STA. 96+79	SR (1800 AV)	O&C/BIT	69			10	2	52.0					0.08	0.10	5.8
LT STA. 101+00	CE	AGG/BIT	78			10	8	---		75			0.06	0.08	33.6*
RT STA. 101+17	PE	BIT/BIT	48			6	2	---					0.01	0.06	3.1
LT STA. 103+00	CE	BIT/BIT	60			10	2	56.0					0.02	0.11	6.3
RT STA. 109+05	FE	GRASS						---					---	---	---
RT STA. 119+66	FE	GRASS						---					---	---	---
RT STA. 130+22	FE	GRASS						---					---	---	---
LT STA. 130+22	FE	GRASS						---					---	---	---
RT STA. 136+56	FE	GRASS						---					---	---	---
RT STA. 151+34	FE	GRASS						---					---	---	---
RT STA. 157+35	FE	AGG						---					---	---	---
LT STA. 158+06	SR (1913 AV)	O&C/BIT	63			10	2	46.2					0.07	0.09	5.2
RT STA. 167+18	FE	GRASS						---					---	---	---
RT STA. 172+46	FE	GRASS						---					---	---	---
LT STA. 185+79	SR (800 ST)	O&C/BIT	116			10	2	91.6					0.13	0.18	10.3
RT STA. 185+96	SR (800 ST)	O&C/BIT	128			10	2	103.1					0.15	0.21	11.5
RT STA. 205+20	FE	GRASS						---					---	---	---
RT STA. 211+51	SR (2000 AV)	O&C/BIT	62			10	2	47.6					0.07	0.10	5.3
LT STA. 211+51	SR (2000 AV)	O&C/BIT	93			10	2	69.3					0.10	0.14	7.8
RT STA. 217+98	FE	GRASS						---					---	---	---
RT STA. 222+73	FE	GRASS						---					---	---	---
RT STA. 228+54	FE	GRASS						---					---	---	---
RT STA. 239+10	FE	GRASS						---					---	---	---
RT STA. 243+33	FE	GRASS						---					---	---	---
RT STA. 260+22	FE	GRASS						---					---	---	---
RT STA. 270+78	FE	GRASS						---					---	---	---
RT STA. 282+93	FE	GRASS						---					---	---	---
LT STA. 282+93	FE	GRASS						---					---	---	---
RT STA. 287+15	FE	GRASS						---					---	---	---
RT STA. 302+46	FE	GRASS						---					---	---	---
RT STA. 318+30	FE	GRASS						---					---	---	---
RT STA. 320+00	CE	BIT/BIT	52			8	2	---					0.02	0.07	4.3
RT STA. 321+66	CE	BIT/BIT	76			8	2	---					0.02	0.12	6.8
RT STA. 323+00	SR (SOUTH ST)	O&C/BIT	115			10	2	92.0					0.13	0.18	10.3
RT STA. 326+17	SR (DAUPIN ST)	O&C/BIT	115			10	2	109.0					0.16	0.22	12.2
LT STA. 326+17	SR (DAUPIN ST)	O&C/BIT	100			10	2	76.9					0.11	0.15	8.6
RT STA. 326+42	CE	BIT/BIT	51			8	2	79.0					0.12	0.16	8.9
RT STA. 326+92	CE	BIT/BIT	51			8	2	79.0					0.11	0.16	8.8
RT STA. 330+51	CH 6	O&C/BIT	92			10	2	66.7					0.10	0.13	7.5
LT STA. 330+29	SR (2193 AV/CH 6)	O&C/BIT	74			10	2	55.6					0.08	0.11	6.2
RT STA. 348+81	FE	GRASS						---					---	---	---

SHEET 3 OF 4

REVISIONS	
NAME	DATE
JCN	2/19/03
KPG	1/2/09

ILLINOIS DEPARTMENT OF TRANSPORTATION
DISTRICT SIX
DETAILS FOR RURAL / URBAN
ENTRANCE, MAILBOX TURNOUT
& SIDEROADS
W / O CONCRETE GUTTER
(PPP - PROJECTS)

SCALE: VERT. DRAWN BY CADD
 HORIZ. CHECKED BY JCN
 DATE: FEBRUARY 23, 1999

F.A.P. RTE.	SECTION	COUNTY	TOTAL SHEETS	SHEET NO.
71	•	LOGAN	14	14
STA.		TO STA.		
FED. ROAD DIST. NO.	ILLINOIS	FED. AID PROJECT		
• 10(RS-2); 11(RS-2)				

ENTRANCE IMPROVEMENT SCHEDULE FOR RURAL / URBAN "PPP" PROJECTS

LOCATION (LT / RT) (STA) (+)	TYPE OF ENTRANCE (FE / PE / CE / MB) (RURAL / URBAN)	MATERIAL TYPE (EX / PR)	WIDTH AT EDGE OF PAVT FOOT	RT OFFSET FOOT	LT OFFSET FOOT	LENGTH (FROM EDGE OF PVT/ BIT SHLD TO LIMITS OF IMPROVEMENT) FOOT	PR BIT. CONC. AVERAGE THICKNESS INCH	BIT. SURF. REM. - BUTT JOINT SQ. YD.	P. C. C. SURF. REM. - BUTT JOINT SQ. YD.	PREP OF BASE SQ. YD.	AGG. BASE REPAIR TON	AGGREGATE SURFACE COURSE TY - B TON	BIT (P. C.) TON	AGG (P. C.) TON	INCIDENTAL BIT. SURF. SUPERPAVE TON
RT STA. 354+62	FE	GRASS						---					---	---	---
RT STA. 356+21	FE	GRASS						---					---	---	---
RT STA. 363+60	FE	GRASS						---					---	---	---
RT STA. 375+74	FE	GRASS						---					---	---	---
RT STA. 386+30	FE	GRASS						---					---	---	---
RT STA. 391+04	SR (2300 AV)	O&C/BIT	55			10	2	40.4					0.06	0.08	4.5
LT STA. 391+04	SR (2300 AV)	O&C/BIT	90			10	2	65.3					0.09	0.13	7.3
RT STA. 404+78	SR (1000 ST)	O&C/BIT	95			10	2	74.2					0.11	0.15	8.3
RT STA. 415+34	FE	GRASS						---					---	---	---
RT STA. 433+82	FE	GRASS						---					---	---	---
RT STA. 449+66	FE	GRASS						---					---	---	---
TOTALS=								1456.3	---	75	---	**	2.16	3.24	210.8

SHEET 4 OF 4

NOTE:

- 8" FULL DEPTH HMA PAVEMENT. SEE NOTE ON SHEET 1 OF 4 FOR MIX DESIGN AND CONSTRUCTION.
- ESTIMATE 20 TONS FOR USE AT VARIOUS ENTRANCES

REVISIONS	
NAME	DATE
JCN	2/19/03
KPG	1/2/09

ILLINOIS DEPARTMENT OF TRANSPORTATION
DISTRICT SIX
DETAILS FOR RURAL / URBAN
ENTRANCE, MAILBOX TURNOUT
& SIDEROADS
W / O CONCRETE GUTTER
(PPP - PROJECTS)

SCALE: VERT. DRAWN BY CADD
 HORIZ. CHECKED BY JCN
 DATE: FEBRUARY 23, 1999