

F.A.P. RTE.	SECTION	COUNTY	TOTAL SHEETS	SHEET NO.
781	2ZRS-1	CRAWFORD	191	122
STA.		TO STA.		
FED. ROAD DIST. NO.	ILLINOIS	FED. AID PROJECT		

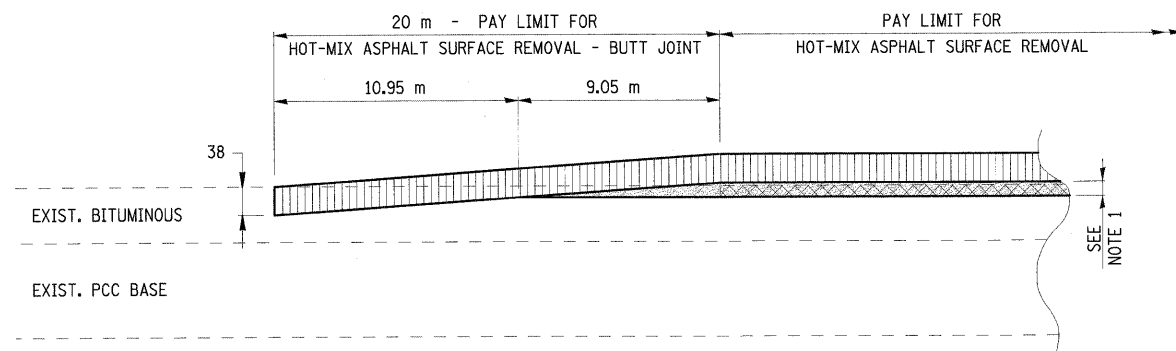

- HOT-MIX ASPHALT SURFACE REMOVAL
- HOT-MIX ASPHALT SURFACE COURSE
- HOT-MIX ASPHALT BINDER COURSE OR LEVEL BINDER

BUTT JOINT DETAIL

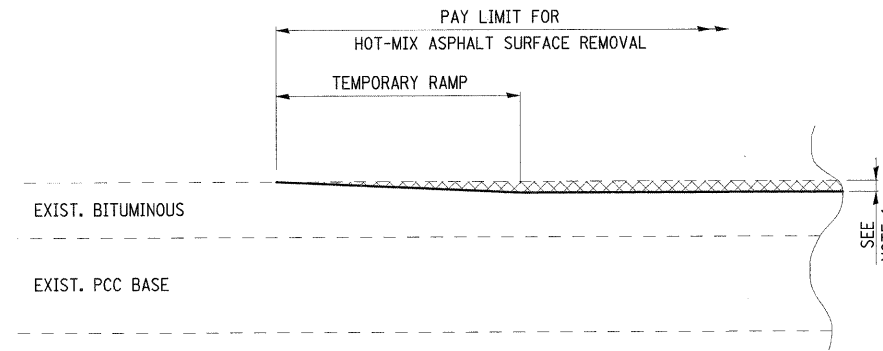

- HOT-MIX ASPHALT SURFACE REMOVAL

MILLED TEMPORARY RAMP

NOTES

- REFER TO THE HOT-MIX ASPHALT SURFACE REMOVAL DETAILS BELOW AND THE HOT-MIX ASPHALT SURFACE REMOVAL SCHEDULE FOR MILLING THICKNESSES.
- BUTT JOINTS AND TEMPORARY RAMPS SHALL BE PLACED AS SHOWN ON THE PLANS OR AS DIRECTED BY THE ENGINEER.
- BUTT JOINTS SHALL BE CONSTRUCTED IMMEDIATELY PRIOR TO THE PLACING OF THE PROPOSED HOT-MIX ASPHALT COURSES.
- TAPER THE TEMPORARY RAMP AT A RATE OF 900mm (3') PER 25mm (1") OF MILLING THICKNESS.
- TEMPORARY RAMPS SHALL BE CONSTRUCTED AT ALL BUTT JOINT LOCATIONS. AT ALL OTHER PAVEMENT TRANSITIONS THE MILLED TEMPORARY RAMP SHALL BE USED. THE INSTALLATION AND SUBSEQUENT REMOVAL OF THE TEMPORARY RAMP WILL BE PAID FOR AT THE CONTRACT UNIT PRICE PER SQUARE METER FOR TEMPORARY RAMP. MILLED TEMPORARY RAMPS WILL NOT BE PAID FOR SEPARATELY, BUT SHALL BE INCLUDED IN THE COST OF HOT-MIX ASPHALT SURFACE REMOVAL.

NOTES

- REFER TO THE HOT-MIX ASPHALT SURFACE REMOVAL SCHEDULE FOR MILLING THICKNESSES AT ϕ AND LOCATIONS WHERE EACH OCCURS.
- MILLING SHALL BE DONE AT THE NOMINAL THICKNESS CALLED FOR AT ϕ ACROSS THE SECTION.
- MILLING TO THE BOTTOM OF WHEEL RUTS SHALL NOT BE NECESSARY UNLESS REQUIRED TO OBTAIN SLOPE OR THE DESIGN DEPTH AT CENTERLINE.
- NOMINAL MILLING AREAS SHALL BE PAID FOR UNDER THE FOLLOWING:
 - M4400715 - HOT-MIX ASPHALT SURFACE REMOVAL, 15mm
 - M4400725 - HOT-MIX ASPHALT SURFACE REMOVAL, 25mm
 - M4400740 - HOT-MIX ASPHALT SURFACE REMOVAL, 40mm

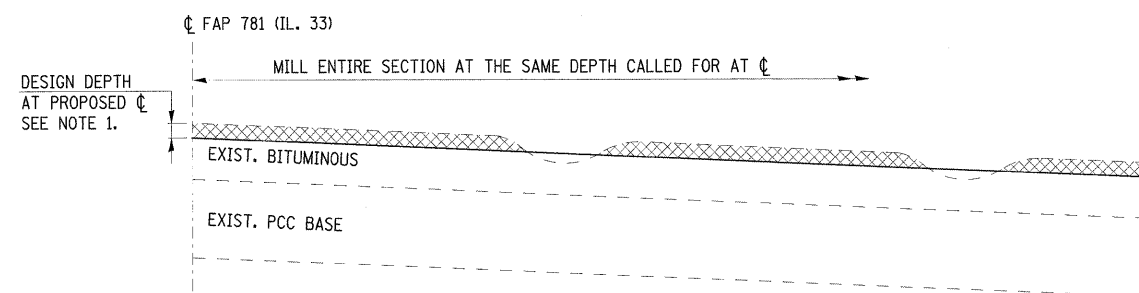

HOT-MIX ASPHALT SURFACE REMOVAL DETAIL (NOMINAL DEPTH)

NOTES

- REFER TO THE HOT-MIX ASPHALT SURFACE REMOVAL SCHEDULE FOR MILLING THICKNESSES AT ϕ AND LOCATIONS WHERE EACH OCCURS.
- MILLING SHALL BE DONE TO ATTAIN THE DESIRED DESIGN CROSSLOPE ACROSS THE SECTION.
- MILLING TO THE BOTTOM OF WHEEL RUTS SHALL NOT BE NECESSARY UNLESS REQUIRED TO OBTAIN SLOPE OR THE DESIGN DEPTH AT CENTERLINE.
- VARIABLE MILLING AREAS SHALL BE PAID FOR UNDER THE FOLLOWING:
 - M4400950 - HOT-MIX ASPHALT SURFACE REMOVAL, VARIABLE DEPTH

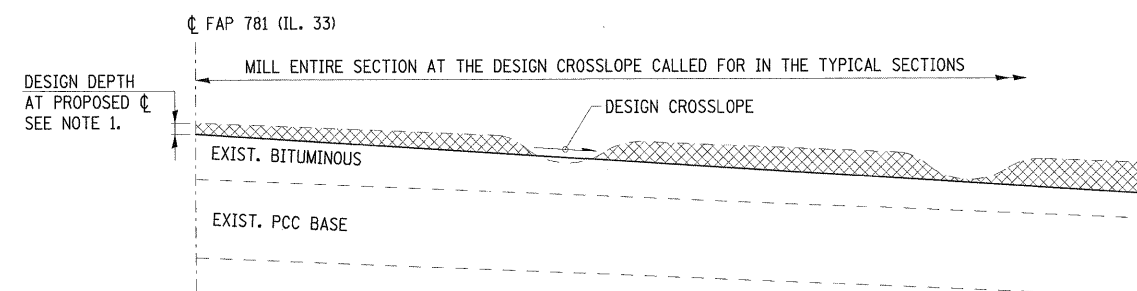

HOT-MIX ASPHALT SURFACE REMOVAL DETAIL (VARIABLE DEPTH)

ALL DIMENSIONS ARE IN MILLIMETERS UNLESS OTHERWISE SHOWN.

REVISIONS		ILLINOIS DEPARTMENT OF TRANSPORTATION
NAME	DATE	
		<p align="center">BUTT JOINT, TAPER AND ASPHALT MILLING DETAILS</p> <p>SCALE NO SCALE DRAWN BY KOJ</p> <p>DATE FEBRUARY 6, 2009 CHECKED BY LWJ</p>

PLOT DATE = 2/5/2009
FILE NAME = H:\4420\Contract 74349\SH1_120_details.dgn

H. M. & G. NO. 4420