

04-22-2016 LETTING ITEM 052

STATE OF ILLINOIS  
DEPARTMENT OF TRANSPORTATION  
DIVISION OF HIGHWAYS

**PROPOSED  
HIGHWAY PLANS**

F.A.I. ROUTE 72 (1-72)  
SECTION D5 CRACK & JOINT SEAL 2016-2

CRACK AND JOINT SEALING  
PIATT COUNTY

C-95-055-15

(WEST FIELD AREA CRACK SEALING)

F.A.I. RTE.	SECTION	COUNTY	TOTAL SHEETS	SHEET NO.
72		PIATT	8	1

ILLINOIS CONTRACT NO. 70B56  
\*D5 CRACK & JOINT SEAL 2016-2

D-95-055-15



LOCATION OF SECTION INDICATED THUS: - [shaded box] -

**ADT**

SEE LOCATION MAP, SHEET 3

FOR LOCATION MAP, SEE SHEET 3

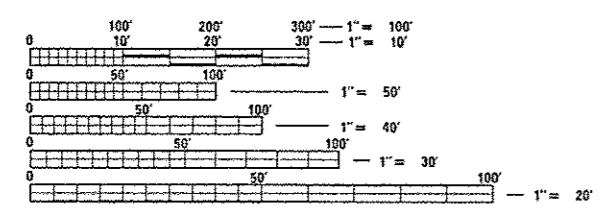

FULL SIZE PLANS HAVE BEEN PREPARED USING STANDARD ENGINEERING SCALES. REDUCED SIZED PLANS WILL NOT CONFORM TO STANDARD SCALES. IN MAKING MEASUREMENTS ON REDUCED PLANS, THE ABOVE SCALES MAY BE USED.

J.U.L.I.E.  
JOINT UTILITY LOCATION INFORMATION FOR EXCAVATION  
1-800-892-0123  
OR 811

PROJECT ENGINEER: NANCY FASIG  
SQUAD LEADER: STEVE COOMBES  
(217)465-4181  
CONTRACT NO. 70B56

STATE OF ILLINOIS  
DEPARTMENT OF TRANSPORTATION  
DIVISION OF HIGHWAYS

SUBMITTED January 26, 2016

[Signature]  
DEPUTY DIRECTOR OF HIGHWAYS, REGION ENGINEER

March 10, 2016  
Maureen M. Adz, P.E.  
ENGINEER OF DESIGN AND ENVIRONMENT

March 10, 2016  
Omer Osman, P.E.  
DIRECTOR OF HIGHWAYS, CHIEF ENGINEER

**PRINTED BY THE AUTHORITY  
OF THE STATE OF ILLINOIS**

## INDEX OF SHEETS

SHEET NO.	DESCRIPTION
1	COVER SHEET
2	INDEX OF SHEETS
2	LIST OF STANDARDS
2	GENERAL NOTES
3	LOCATION MAP
4	SUMMARY OF QUANTITIES
5 - 10	EXISTING TYPICAL CROSS SECTIONS
11	DETAIL FOR CRACK AND JOINT SEALING

## LIST OF STANDARDS

STANDARD NO.	NAME OF STANDARD
000001-06	STANDARD SYMBOLS, ABBREVIATIONS AND PATTERNS
001006	DECIMAL OF AN INCH AND OF A FOOT
701400-08	APPROACH TO LANE CLOSURE, FREEWAY/EXPRESSWAY
701406-10	LANE CLOSURE, FREEWAY/EXPRESSWAY, DAY OPERATIONS ONLY
701411-09	LANE CLOSURE, MULTILANE, AT ENTRANCE OR EXIT RAMP, FOR SPEEDS ≥ 45 MPH
701901-05	TRAFFIC CONTROL DEVICES

## GENERAL NOTES

G.N. 100

ENGLISH UNITS OF MEASUREMENT SHALL GOVERN OVER AND SUPERSEDE ANY METRIC UNITS SHOWN IN THIS CONTRACT. WHERE INCLUDED, METRIC UNITS ARE FOR INFORMATION ONLY.

G.N. 100A

ELECTRONIC FILES AND/OR ELECTRONIC SURVEY INFORMATION INCLUDING CADD FILES WILL NOT BE AVAILABLE TO THE CONTRACTOR.

G.N. 451 (SPECIAL)

THE INTENT OF THIS PROJECT IS TO ONLY BLOW OUT AND SEAL THE LONGITUDINAL JOINTS & CRACKS (I.E. - NO ROUTING). ANY CHANGES TO THE INTENT OF ROUTING AND SEALING OPERATIONS SHALL BE APPROVED IN ADVANCE BY THE ENGINEER.

LOCATIONS SHALL BE DONE IN THE NUMERICAL ORDER GIVEN IN THE PLANS.

THE FOLLOWING APPLICATION RATES WERE USED TO CALCULATE MATERIAL FOR SEALING JOINTS AND CRACKS AT ALL LOCATIONS:

LONGITUDINAL (OR NON-ROUTED) = 0.2 LBS / LINEAR FOOT

ALL PCC BRIDGE DECKS AND PAVEMENTS ARE TO BE OMISSIONS. BRIDGE DECKS WITH HMA OVERLAYS ARE TO BE SEALED ONLY (NO ROUTING).

LOCATION #1 - I-72 IN PIATT COUNTY FROM MACON COUNTY LINE TO CHAMPAIGN COUNTY LINE.

- 1) LONGITUDINAL JOINTS AND CRACKS EQUAL TO OR GREATER THAN 1/4" IN WIDTH ALONG CENTER LINE, TURN LANES, EDGE OF PAVEMENT / SHOULDERS AND OTHER PAVING JOINTS (AS DIRECTED BY THE ENGINEER) SHALL BE SEALED.
- 2) LONGITUDINAL CRACKS WITHIN THE MARKED LANES SHALL **NOT** BE SEALED.
- 3) LONGITUDINAL PAVING JOINTS, PARALLEL TO THE MAINLINE, AT SIDE ROADS AND ENTRANCES SHALL BE SEALED AS NEEDED. ALL OTHER CRACKS AT THESE LOCATIONS ARE TO BE OMITTED.
- 4) LONGITUDINAL JOINTS WITH DOUBLE CRACKS ALONG THE CENTERLINE OR ALONG THE EDGE OF PAVEMENT / SHOULDER SHALL BE SEALED AS NEEDED.

APPROXIMATE QUANTITIES AT THIS LOCATION:

LONGITUDINAL : 452,768 (RURAL) + 184,000 (URBAN) = 636,768 FOOT  
SEALER : 90,354 (RURAL) + 36,800 (URBAN) = 127,354 POUNDS

# ADT

## LOCATION #1 MAP

### I- 72 FROM THE MACON COUNTY LINE EAST TO THE CHAMPAIGN COUNTY LINE PIATT COUNTY

LOCATION #1 FAI 72 ( I 72)  
FROM MACON CO. LINE EAST  
TO THE CHAMPAIGN CO. LINE

AVERAGE ADT = 13, 500

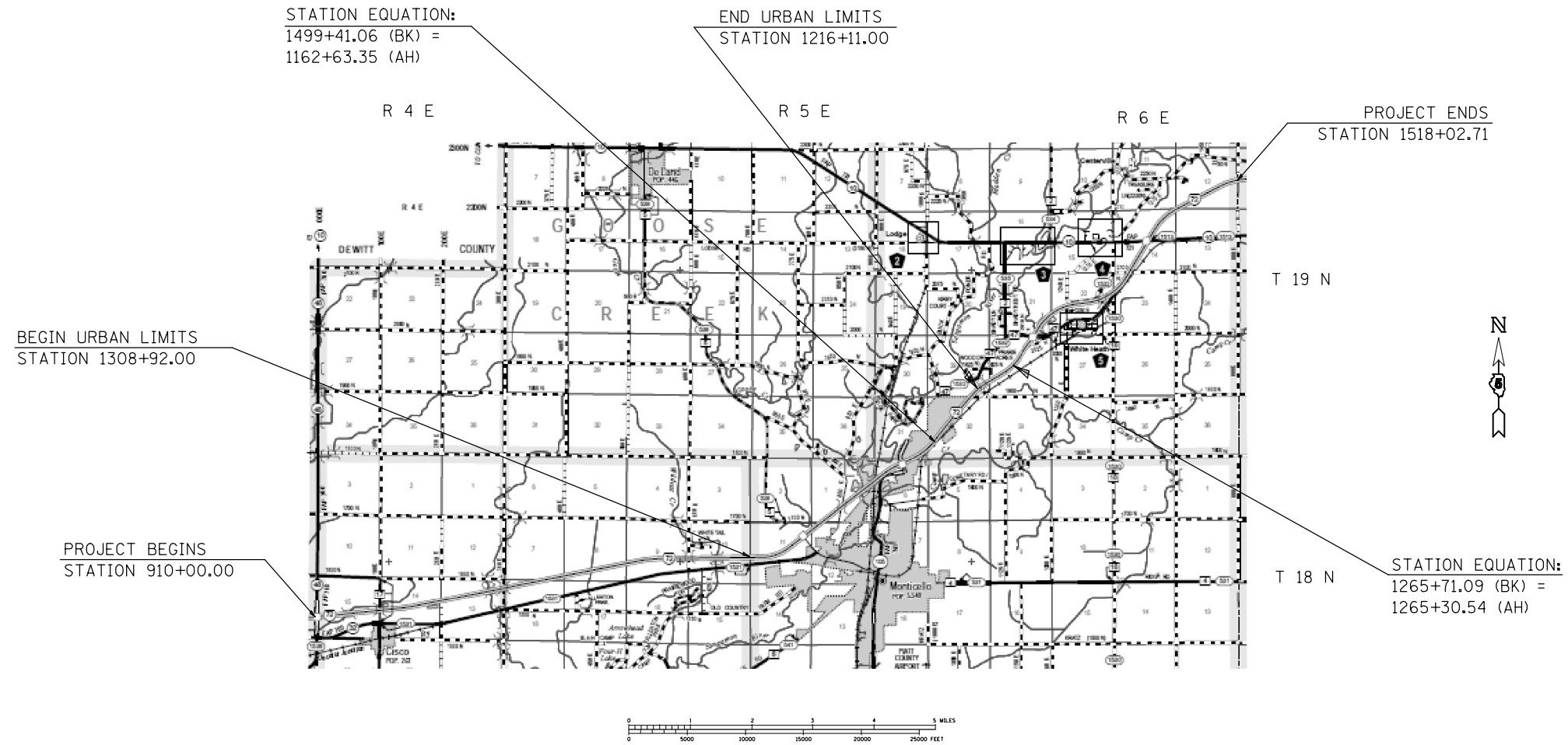

TOTAL LENGTH OF SECTION & PROJECT = 94,520.97 FEET = 17.902 MILES  
NET LENGTH OF SECTION & PROJECT = 94,520.97 FEET = 17.902 MILES

FILE NAME =	USER NAME = coombessf	DESIGNED -	REVISED -	<b>STATE OF ILLINOIS DEPARTMENT OF TRANSPORTATION</b>	<b>LOCATION #1 MAP</b>			F.A.I. RTE.	SECTION	COUNTY	TOTAL SHEETS	SHEET NO.
p:\11\084EBIDINTEG.illinois.gov\PIWIDOT\Documents\IDOT Offices\District 5\Projects\057\DRAWING\0570856-shr-plan.dgn		CHECKED -	REVISED -		72	•	VARIOUS	8	3			
		DATE -	REVISED -		SCALE: N/A			SHEET NO. 1 OF 1 SHEETS STA. TO STA.				
								ILLINOIS FED. AID PROJECT				

F.A.I. RTE.	SECTION	COUNTY	TOTAL SHEETS	SHEET NO.
72	•	VARIOUS	8	3
•D5 CRACK & JOINT SEAL 2016-2			CONTRACT NO. 70B56	
ILLINOIS FED. AID PROJECT				

## SUMMARY OF QUANTITIES

LOCATION OF WORK	LOCATION	
	#1	
COUNTY	PIATT	
	FAI 72	
	I-72	
FUNDING BREAKOUT	RURAL	URBAN
	100% STATE	
CONSTRUCTION CODE	0005	

CODE NO	ITEM DESCRIPTION	UNIT	TOTAL		
45100200	CRACK FILLING	POUND	113,425.0	84,149.0	29,276.0
67100100	MOBILIZATION	L SUM	1.0	0.7	0.3
70100420	TRAFFIC CONTROL AND PROTECTION, STANDARD 701411	EACH	16.0	8.0	8.0
70100700	TRAFFIC CONTROL AND PROTECTION, STANDARD 701406	L SUM	1.0	0.7	0.3
X7010410	SPEED DISPLAY TRAILER	CAL MO	2.0	1.5	0.5
X7015005	CHANGEABLE MESSAGE SIGN	CAL DA	6.0	3.0	3.0
*DENOTES SPECIALTY ITEM					

\*\*SEE GENERAL NOTE 451 (SPECIAL) FOR SPECIFIC ROUT & SEAL INSTRUCTIONS AT THIS LOCATION.

### ① LOCATION 1 (I-72) EXISTING TYPICAL CROSS SECTION

STATION TO STATION  
910+00.00 965+00.00

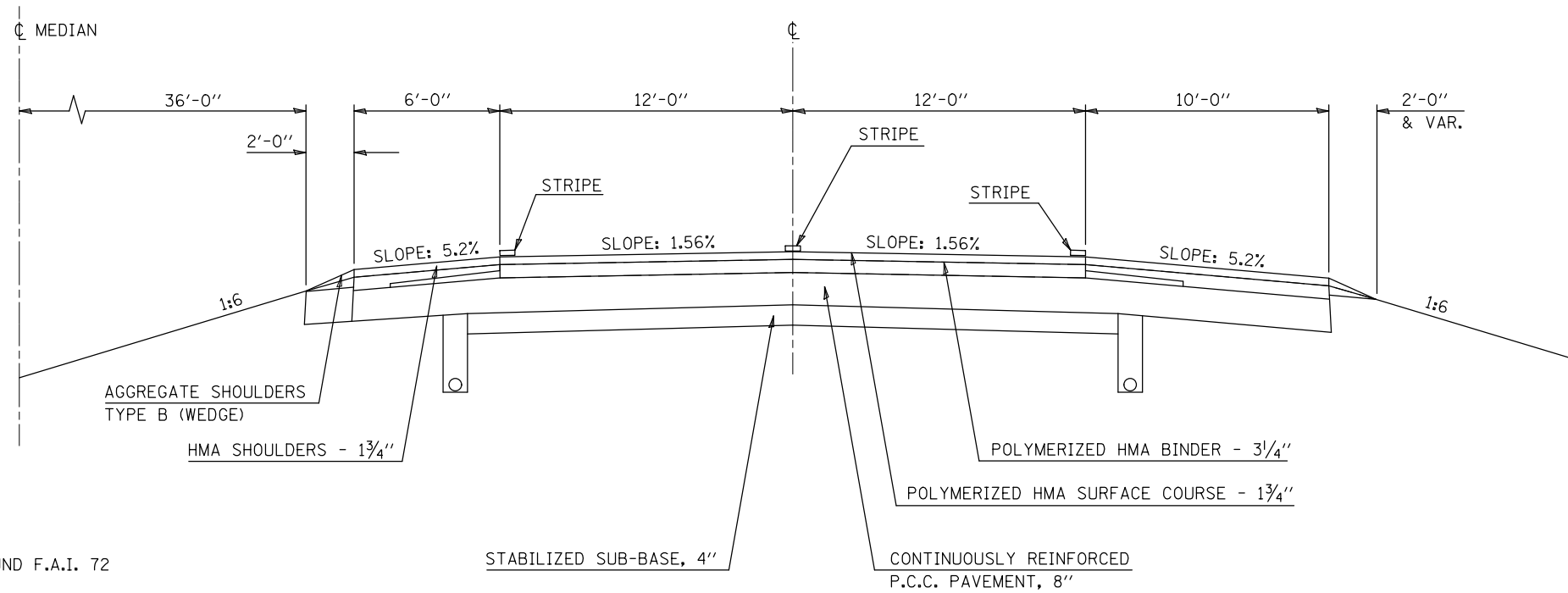

EASTBOUND F.A.I. 72 SHOWN, TYPICAL FOR WESTBOUND F.A.I. 72

\*\*SEE GENERAL NOTE 451 (SPECIAL) FOR SPECIFIC ROUT & SEAL INSTRUCTIONS AT THIS LOCATION.

### ② LOCATION 1 (I-72) EXISTING TYPICAL CROSS SECTION

STATION TO STATION  
965+00.00 1210+00.00

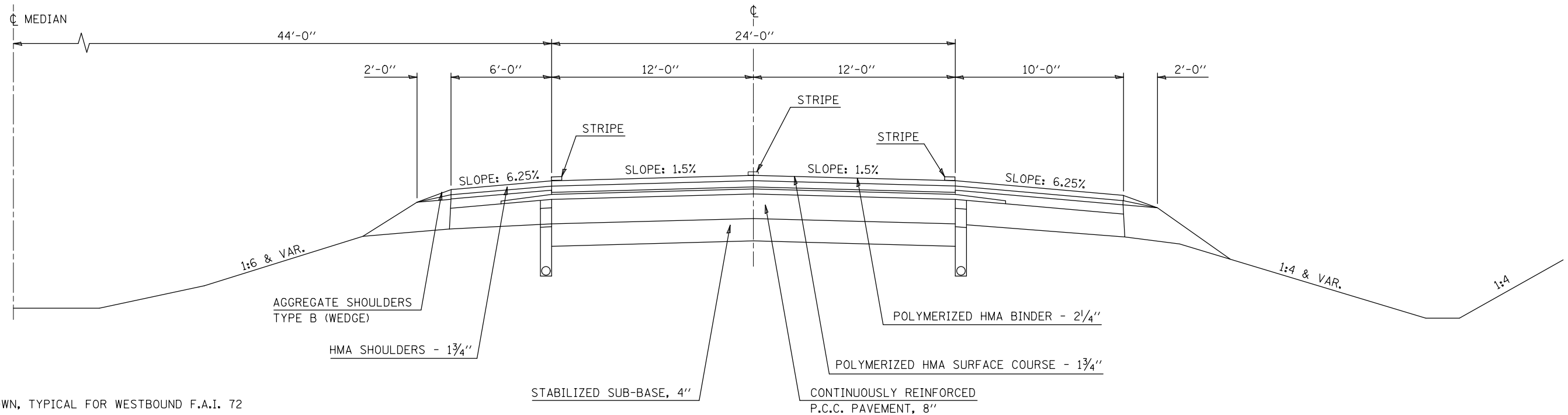

EASTBOUND F.A.I. 72 SHOWN, TYPICAL FOR WESTBOUND F.A.I. 72

FILE NAME =	USER NAME = coombessf	DESIGNED -	REVISED -	<b>STATE OF ILLINOIS DEPARTMENT OF TRANSPORTATION</b>	<b>EXISTING TYPICAL CROSS SECTIONS LOCATION #1 (I-72)</b>			F.A.I. RTE.	SECTION	COUNTY	TOTAL SHEETS	SHEET NO.		
p:\IL\084EBID\INTEG.illinois.gov\PIWIDOT\Documents\IDOT Offices\District 5\Projects\0570856\Design\0570856-shr-plan.dgn		DRAWN	REVISED -		SCALE: N/A	SHEET 1	OF 3	SHEETS	STA.	TO STA.	72	VARIOUS	8	5
*MODELNAME*	PLOT SCALE = 40.0000' / in.	CHECKED -	REVISED -					*D5 CRACK & JOINT SEAL 2016-2			CONTRACT NO. 70B56			
	PLOT DATE = 1/15/2016	DATE -	REVISED -					ILLINOIS FED. AID PROJECT						

\*\*SEE GENERAL NOTE 451 (SPECIAL) FOR SPECIFIC ROUT & SEAL INSTRUCTIONS AT THIS LOCATION.

**3** **LOCATION 1 (I-72)**  
**EXISTING TYPICAL CROSS SECTION**

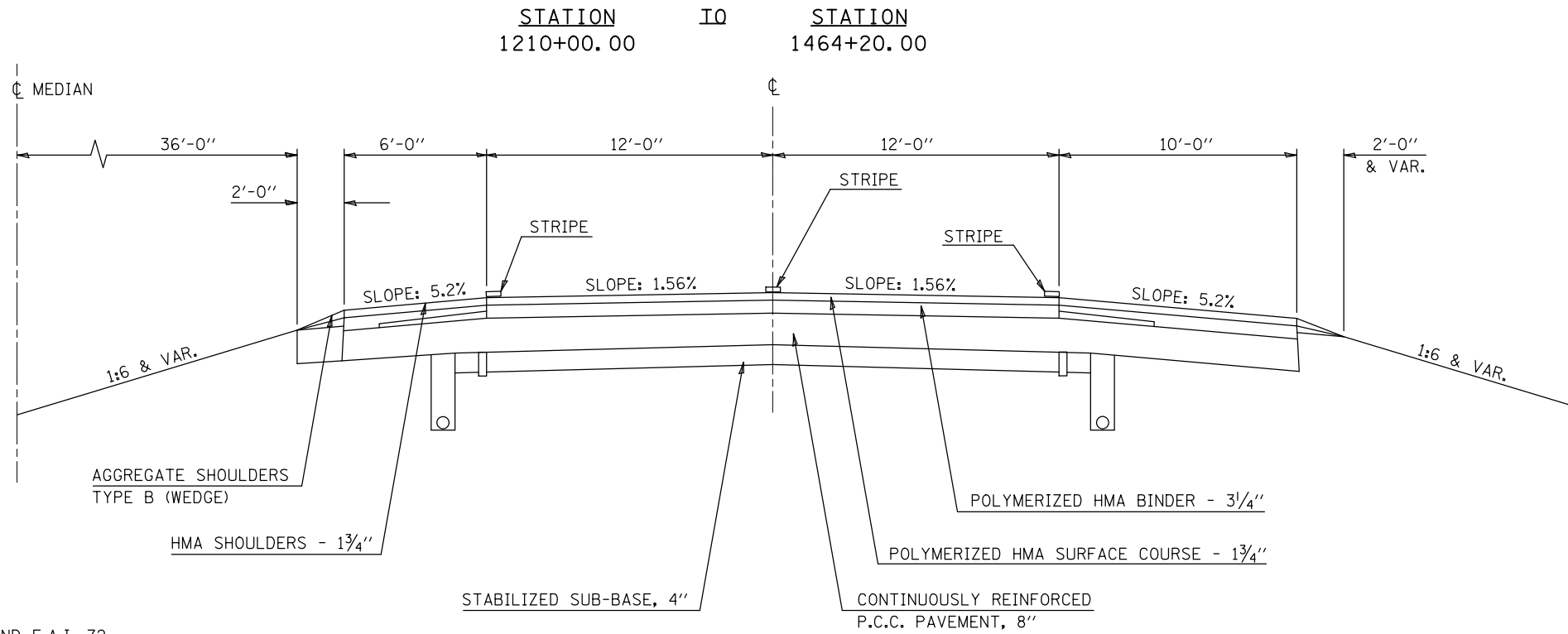

EASTBOUND F.A.I. 72 SHOWN, TYPICAL FOR WESTBOUND F.A.I. 72

\*\*SEE GENERAL NOTE 451 (SPECIAL) FOR SPECIFIC ROUT & SEAL INSTRUCTIONS AT THIS LOCATION.

**4** **LOCATION 1 (I-72)**  
**EXISTING TYPICAL CROSS SECTION**

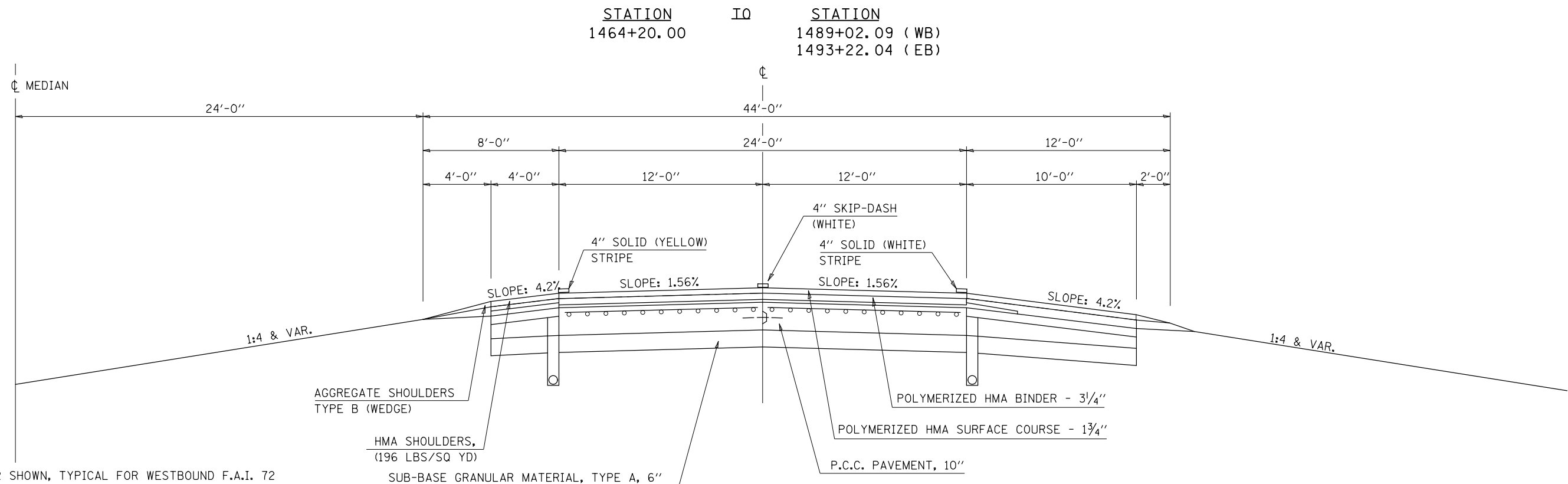

EASTBOUND F.A.I. 72 SHOWN, TYPICAL FOR WESTBOUND F.A.I. 72

FILE NAME =	USER NAME = coombessf	DESIGNED -	REVISED -	<b>STATE OF ILLINOIS DEPARTMENT OF TRANSPORTATION</b>	<b>EXISTING TYPICAL CROSS SECTIONS LOCATION #1 (I-72)</b>			F.A.I. RTE.	SECTION	COUNTY	TOTAL SHEETS	SHEET NO.	
p:\1\084EBIDINTEG.illinois.gov\PIWIDOT\Documents\DOT Offices\District 5\Projects\057\DRAWING\0570856-shr-plan.dgn		CHECKED -	REVISED -		SCALE: N/A	SHEET 2	OF 3 SHEETS	STA.	TO STA.	72	VARIOUS	8	6
\$MODELNAME\$		DATE -	REVISED -							*D5 CRACK & JOINT SEAL 2016-2			
										CONTRACT NO. 70B56			

\*\*SEE GENERAL NOTE 451 (SPECIAL) FOR SPECIFIC ROUT & SEAL INSTRUCTIONS AT THIS LOCATION.

**5** **LOCATION 1 (I-72)**  
**EXISTING TYPICAL CROSS SECTION**

STATION	TO	STATION	
1489+02.09	WB	1499+41.06	(BK) STA. EQN.
1493+22.04	EB	1499+41.06	(BK) STA. EQN.
1162+63.36	(AH)	1265+71.10	(BK) STA. EQN.
1265+30.54	(AH)	1376+84.00	

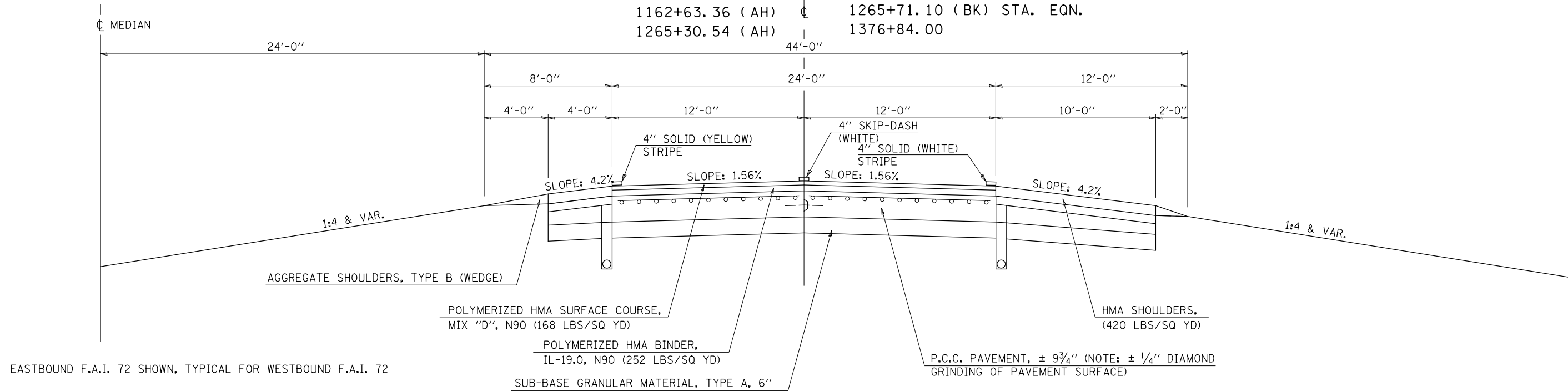

\*\*SEE GENERAL NOTE 451 (SPECIAL) FOR SPECIFIC ROUT & SEAL INSTRUCTIONS AT THIS LOCATION.

**6** **LOCATION 1 (I-72)**  
**EXISTING TYPICAL CROSS SECTION**

STATION	TO	STATION
1376+84.00		1518+02.71

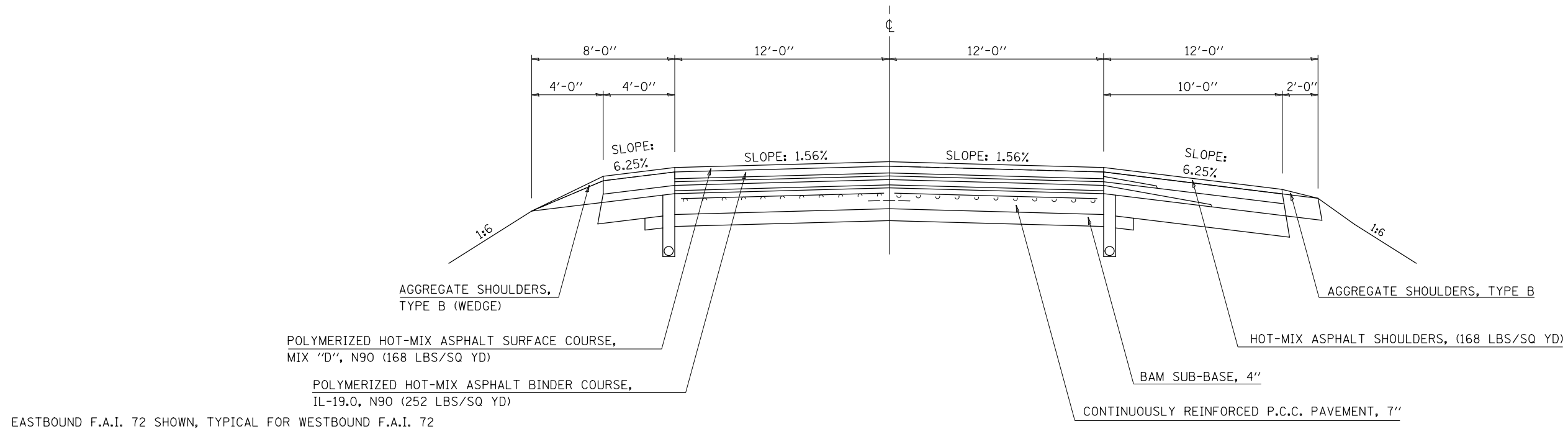

FILE NAME =	USER NAME = coombessf	DESIGNED -	REVISED -	<b>STATE OF ILLINOIS DEPARTMENT OF TRANSPORTATION</b>	<b>EXISTING TYPICAL CROSS SECTIONS LOCATION #1 (I-72)</b>			F.A.I. RTE.	SECTION	COUNTY	TOTAL SHEETS	SHEET NO.
pw:\IL\084EBIDINTEG.illinois.gov\PIDOT\Documents\IDOT Offices\District 5\Projects\0577\DRAWING\0577\Design\05770856-shr-plan.dgn	DESIGNED -	REVISED -	REVISED -					72		VARIOUS	8	7
*MODELNAME*	PLOT SCALE = 40.0000' / in.	CHECKED -	REVISED -		SCALE: N/A SHEET 2 OF 3 SHEETS STA. TO STA.			*DS CRACK & JOINT SEAL 2016-2 CONTRACT NO. 70B56				
	PLOT DATE = 1/15/2016	DATE -	REVISED -		ILLINOIS FED. AID PROJECT							

### HMA PAVEMENT

(USE PAY ITEMS : 45100100 CRACK ROUTING (PAVEMENT)  
AND 45100200 CRACK FILLING)

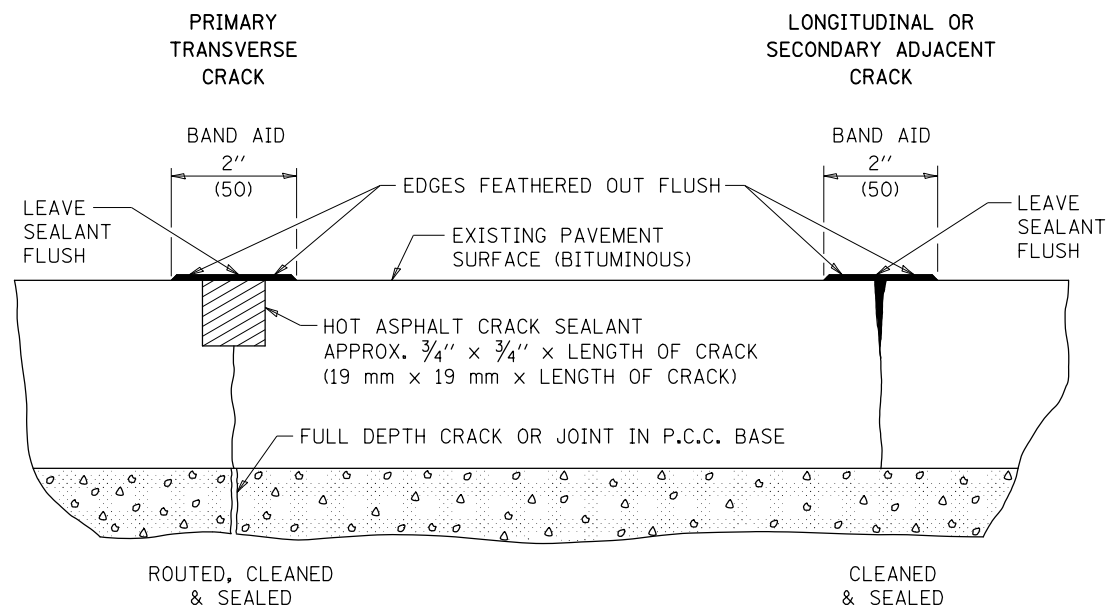

### PCC PAVEMENT

(USE PAY ITEMS : 45200100 JOINT OR CRACK ROUTING (P.C.C. PAVEMENT & SHOULDER)  
AND 45200300 JOINT OR CRACK FILLING)

#### TRANSVERSE CRACKS AND JOINTS AND CENTERLINE JOINT

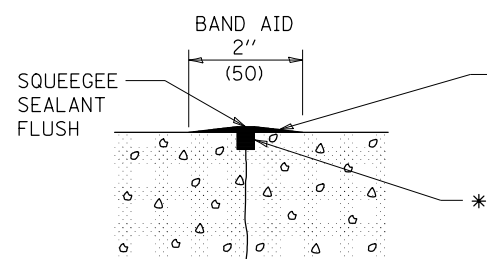

#### LONGITUDINAL SHOULDER JOINT

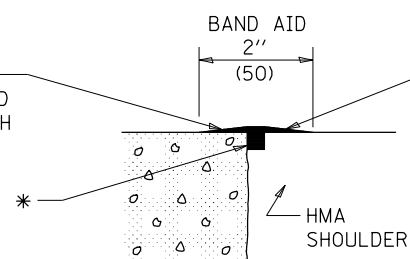

#### ANY WIDE LONGITUDINAL JOINT OR CRACK

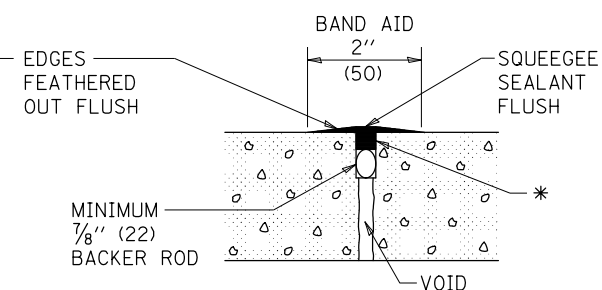

\* HOT ASPHALT CRACK SEALANT  
APPROX. 3/4 \" x 3/4 \" x LENGTH OF CRACK.  
ACTUAL QUANTITY WILL VARY AS NEEDED FOR  
PRIMARY OR SECONDARY WORKING CRACK.

#### LONGITUDINAL RANDOM CRACK

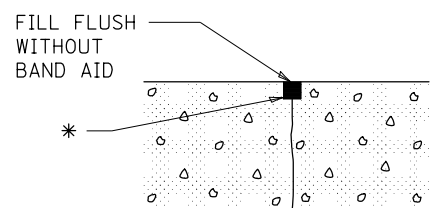

#### TRANSVERSE EXPANSION JOINT

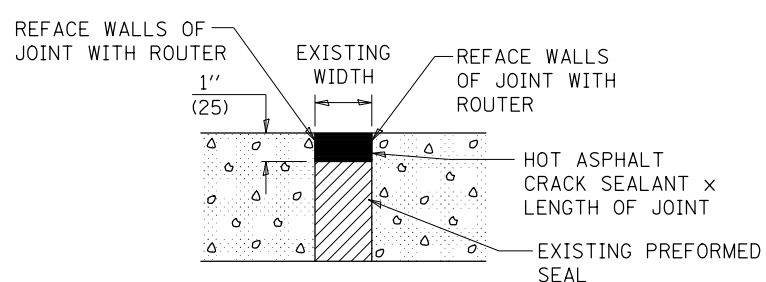

Note: All dimensions are in INCHES  
(millimeters) unless otherwise shown.

FILE NAME =	USER NAME = coombessf	DESIGNED -	REVISED - 12/06
pw:\IL\084EBIDINTEG.illinois.gov\PIWIDOT\Documents\DOT Offices\District 5\Projects\0579\Drawings\Design\0570856-shr-plan.dgn		CHECKED -	REVISED - 08/07
		DATE -	REVISED - 12/08
			REVISED -

STATE OF ILLINOIS  
DEPARTMENT OF TRANSPORTATION

CRACK AND JOINT SEALING

SCALE: SHEET NO. 1 OF 1 SHEETS STA. TO STA.

#### DISTRICT 5 DETAIL NO. 45AAAAAA

F.A.I. RTE.	SECTION	COUNTY	TOTAL SHEETS	SHEET NO.
72	*	VARIOUS	8	8
*D5 CRACK & JOINT SEAL 2016-2			CONTRACT NO. 70B56	
FED. ROAD DIST. NO.		ILLINOIS FED. AID PROJECT		