

**SECTION A-A**

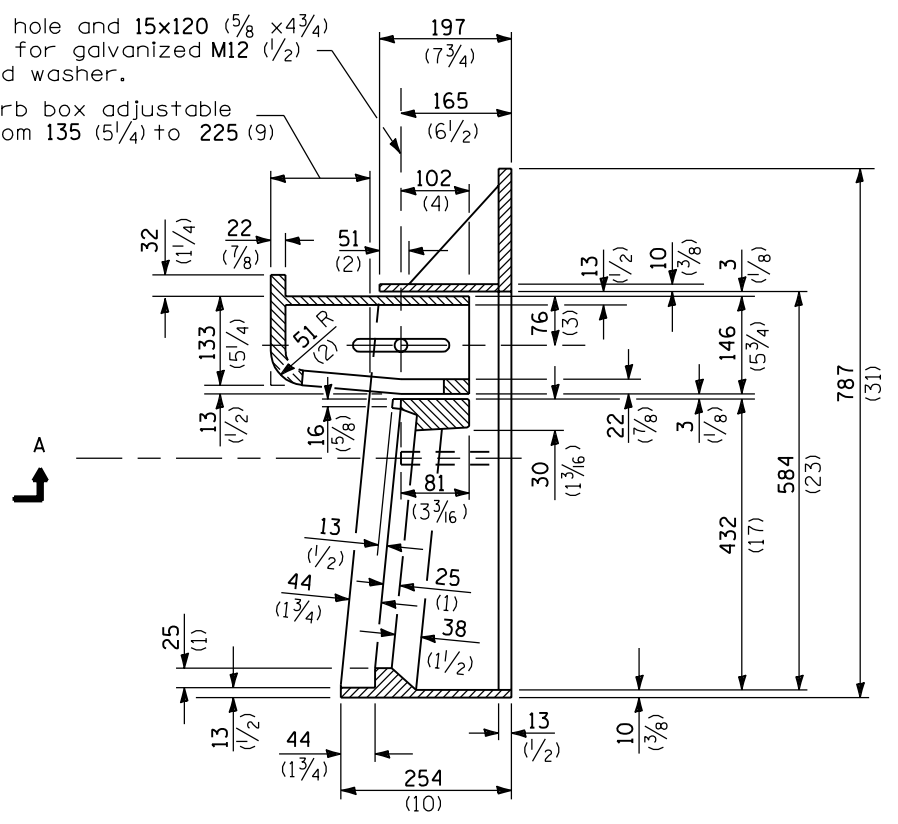

**SECTION B-B**

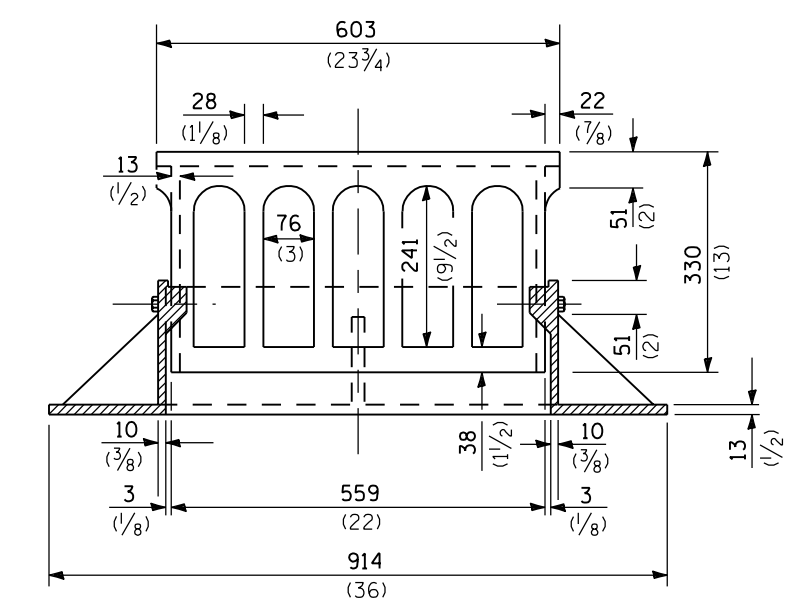

**SECTION C-C**

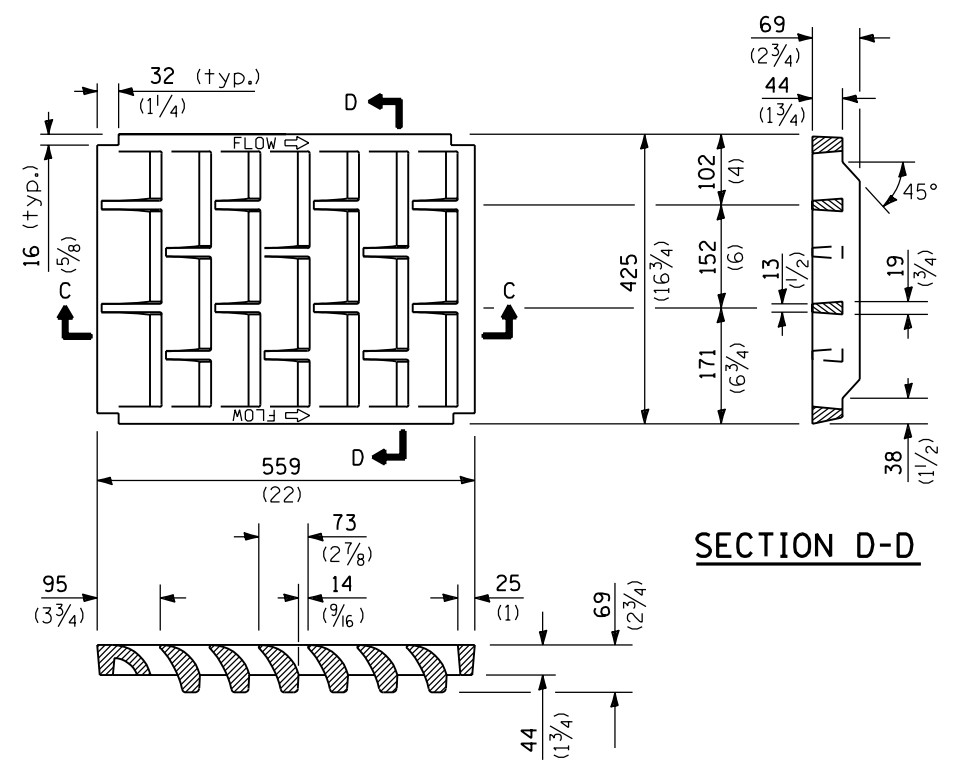

**SECTION D-D**

**CAST GRATE**

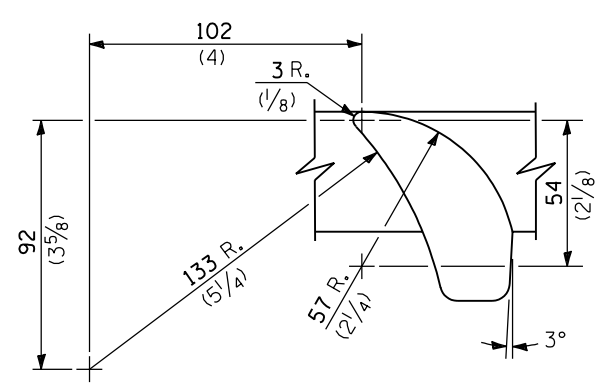

**VANE DETAILS**

**CAST FRAME**

All dimensions are in millimeters (inches) unless otherwise shown.

Illinois Department of Transportation

PASSED January 1, 2004  
*Michael Brand*  
 ENGINEER OF POLICY AND PROCEDURES

APPROVED January 1, 2004  
*Michael L. Hine*  
 ENGINEER OF DESIGN AND ENVIRONMENT

ISSUED 26-1-1

DATE	REVISIONS
1-1-04	Revised frame and removed weights.
1-1-02	Added support bar to rear of frame opening & rev. frame thickness.

**FRAME AND GRATE  
TYPE 3V**

**STANDARD 604011-02**