

TRUSS UNIT TABLE

| Structure Number | Station | Design Truss Type | Exterior Units (2) | | | Interior Unit | | | Upper & Lower Chord | | Verticals, Horizontals, Vertical, Horizontal, and Interior Diagonals | | Camber at Midspan | Splicing Flange | | | | | | |
|------------------|---------|-------------------|---------------------|-----------------------------|----------------|---------------|---------------------|-----------------------------|---------------------|--------|--|--------|-------------------|-----------------|------------|------|------------|----------------|---------|---------|
| | | | No. Panels per Unit | Unit Lgth.(L _u) | Panel Lgth.(P) | No. Req'd. | No. Panels per Unit | Unit Lgth.(L _i) | Panel Lgth.(P) | O.D. | Wall | O.D. | | Wall | Bolts | | Weld Sizes | | | |
| | | | | | | | | | | | | | | | No./Splice | Dia. | W | W ₁ | A | B |
| 2S101U020R020.7 | 1094+86 | II-A | 7 | 38'-5 3/4" | 5'-2 3/4" | 1 | 6 | 32'-7 1/2" | 5'-2 3/4" | 6 1/2" | 5/16" | 3" | 5/16" | 3 1/2" | 6 | 1" | 3/8" | 1/4" | 11" | 14 1/2" |
| 2S101U020R019.8 | 1047+60 | I-A | 6 | 29'-9" | 4'-7 3/4" | 1 | 6 | 29'-1 1/2" | 4'-7 3/4" | 5" | 5/16" | 2 1/2" | 5/16" | 2 5/8" | 6 | 7/8" | 5/16" | 1/4" | 8 3/4" | 11 1/4" |
| 2S0811074R003.4 | 404+30 | II-A | 6 | 32'-1 1/2" | 5'-0 1/2" | 1 | 6 | 31'-6" | 5'-0 1/2" | 6 1/2" | 5/16" | 3" | 5/16" | 2 3/4" | 6 | 1" | 3/8" | 1/4" | 11" | 14 1/2" |
| 2S0811088R000.5 | 257+75 | II-A | 8 | 39'-4 1/2" | 4'-8 1/4" | 1 | 8 | 38'-9" | 4'-8 1/4" | 7" | 5/16" | 3" | 5/16" | 4" | 6 | 1" | 3/8" | 1/4" | 11 1/2" | 15" |
| 2S0811088L000.8 | 275+25 | II-A | 6 | 34'-1 1/2" | 5'-4 1/2" | 1 | 6 | 33'-6" | 5'-4 1/2" | 6 1/2" | 5/16" | 3" | 5/16" | 3" | 6 | 1" | 3/8" | 1/4" | 11" | 14 1/2" |

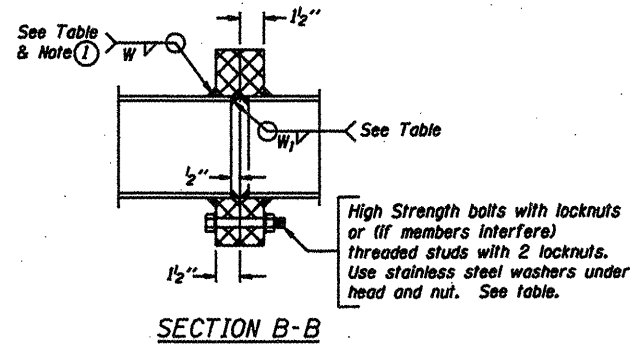

① Splicing Flanges shall be attached to each truss unit with the truss shop assembled to camber shown. Truss units shall be in proper alignment and flange surfaces shall be shop bolted into full contact before welding. Sufficient external welds or tacks shall be made to secure flanges until remaining welds are made after disassembly. Adjacent flanges shall be "match marked" to insure proper field assembly.

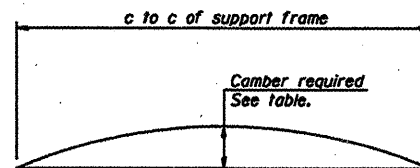
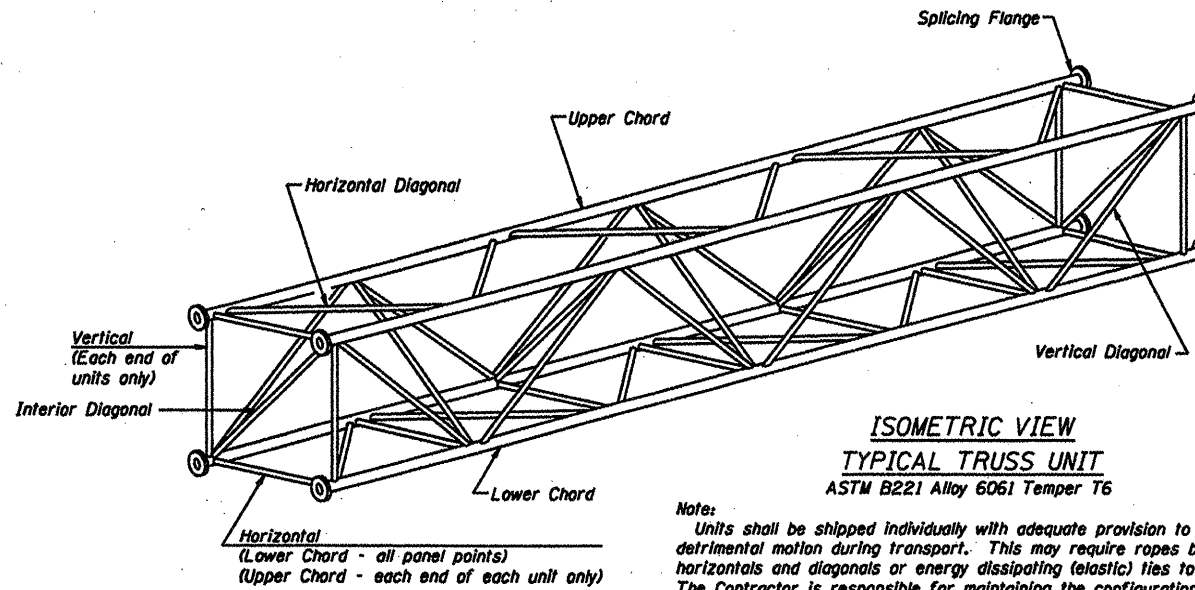

CAMBER DIAGRAM

Camber curve shown is theoretical. Actual camber attained by slope changes at splices between units.

CAMBER ATTAINMENT EXAMPLES:

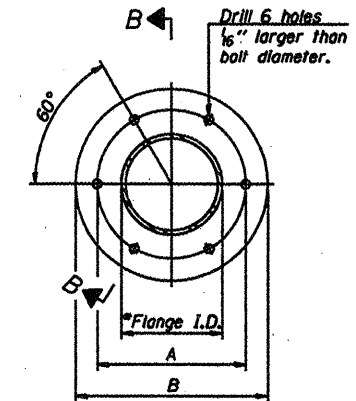
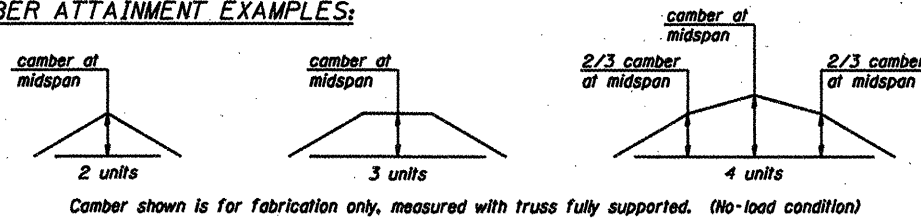

TRUSS TYPES I-A, II-A, & III-A

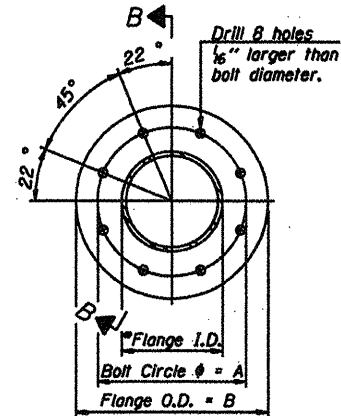

TRUSS TYPES II-A & III-A

SPLICING FLANGES

ASTM B221, Alloy 6061-T6
or ASTM B209, Alloy 6061-T651
*To fit O.D. of Chord with maximum gap of 1/16".

| NUMBER | REVISION | DATE |
|--------|----------|------|
| | | |
| | | |
| | | |
| | | |
| | | |
| | | |

OS4-A-2

12-1-08

OVERHEAD SIGN STRUCTURES
ALUMINUM TRUSS DETAILS
FOR TRUSS TYPES I-A, II-A AND III-A

| | | | | | | | | | | |
|---|-------------|------------|-----------|---|--|-----------|-------------------------------|--------|---------------------------|-----------|
| FILE NAME # | USER NAME # | DESIGNED - | REVISED - | STATE OF ILLINOIS DEPARTMENT OF TRANSPORTATION | District 2 Sign Structure Replacement | F.A. RTE. | SECTION | COUNTY | TOTAL SHEETS | SHEET NO. |
| #FILE# | | DRAWN - | REVISED - | | | ** | D-2 OVD SIGN STR REPL 2010-35 | ** | 31 | 6 |
| | | CHECKED - | REVISED - | | | ** | Rack Island & Winnebago | ** | CONTRACT NO. 4601 | |
| | | DATE - | REVISED - | | | ** | Various | ** | ILLINOIS FED. AID PROJECT | |
| SCALE: SHEET NO. OF SHEETS STA. TO STA. | | | | | | | | | | |