

F.A.P. RTE.	SECTION	COUNTY	TOTAL SHEETS	SHEET NO.
350	50-1 VB-1-BR	COOK	23	1
FED. ROAD DIST. NO.	ILLINOIS	CONTRACT NO. 60H76		

**STATE OF ILLINOIS**  
**DEPARTMENT OF TRANSPORTATION**  
**DIVISION OF HIGHWAYS**

**PROPOSED**  
**HIGHWAY PLANS**

**FAP ROUTE 350: IL 50 (CICERO AVE)**  
**SECTION: 50-1 VB-1-BR**  
**OVER BRC RR (SN 016-2512, -2513)**  
**BRIDGE JOINT RECONSTRUCTION AND**  
**SUBSTRUCTURE REPAIRS**  
**COOK COUNTY**  
**C-91-789-09**

FOR INDEX OF SHEETS, SEE SHEET NO. 2

**TRAFFIC DATA**

EXISTING ADT = 47,900 TO 61,000 (2007)  
 POSTED SPEED LIMIT = 35 MPH

THE PROJECT IS LOCATED IN THE CITY OF CHICAGO AND IN THE VILLAGE OF BEDFORD PARK.

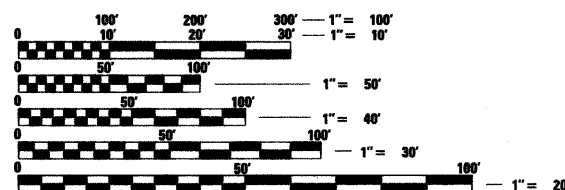
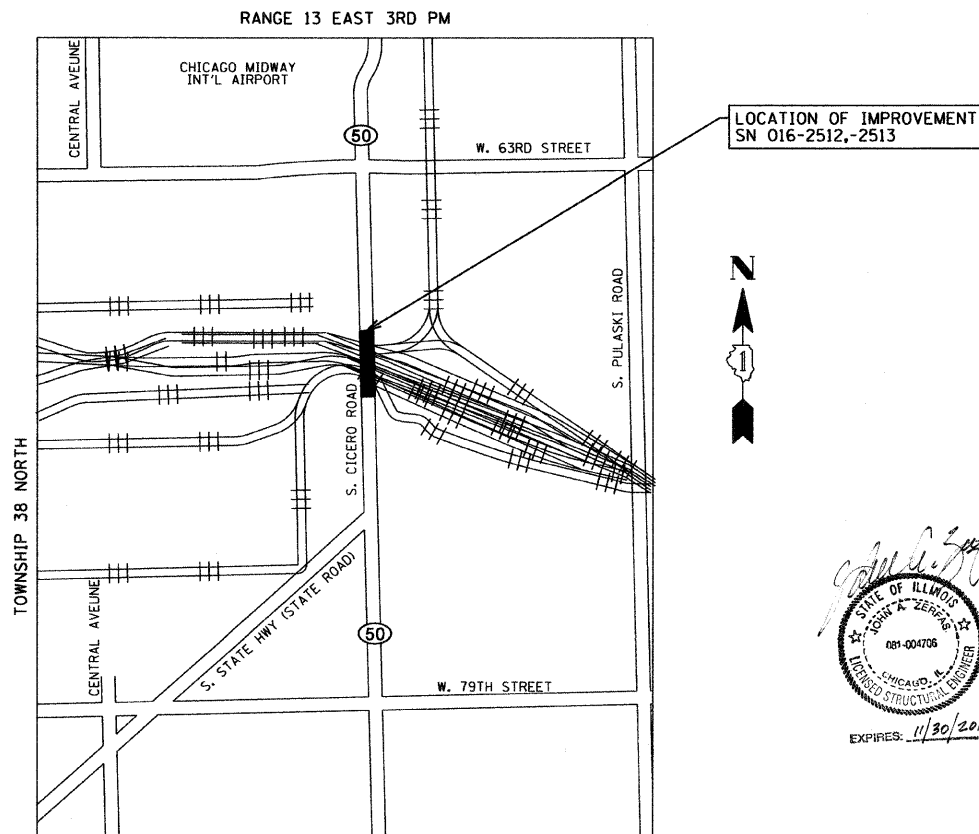

FULL SIZE PLANS HAVE BEEN PREPARED USING STANDARD ENGINEERING SCALES. REDUCED SIZED PLANS WILL NOT CONFORM TO STANDARD SCALES. IN MAKING MEASUREMENTS ON REDUCED PLANS, THE ABOVE SCALES MAY BE USED.

J.U.L.I.E.  
 JOINT UTILITY LOCATION INFORMATION  
 FOR EXCAVATION 1-800-892-0123 OR 811  
 D.I.G.O.E.R. FOR EXCAVATION IN THE  
 CITY OF CHICAGO AT 1-312-744-7000

PROJECT ENGINEER: ROBERT BORO (IDOT) (847) 705-4178  
 PROJECT MANAGER: KEN ENG (IDOT) 847-705-4247

CONTRACT NO. 60H76

GROSS & NET LENGTH OF IMPROVEMENT: 669 FT ( 0.13 MILES)



**GRÄEF**  
 8501 W. Higgins Road, Suite 280  
 Chicago, Illinois 60631  
 (773) 399-0112

STATE OF ILLINOIS  
 DEPARTMENT OF TRANSPORTATION  
 DIVISION OF HIGHWAYS

SUBMITTED October 16, 2009

*Devin M. O'Keefe*  
 DEPUTY DIRECTOR OF HIGHWAYS, REGION ENGINEER

December 4, 2009  
*Charles J. Jorgensen*  
 ENGINEER OF DESIGN AND ENVIRONMENT

December 4, 2009  
*Christine M. Reed*  
 DIRECTOR OF HIGHWAYS, CHIEF ENGINEER

**PRINTED BY THE AUTHORITY  
 OF THE STATE OF ILLINOIS**

INDEX OF SHEETS

SHEET NO.	DESCRIPTION
1	COVER SHEET
2	INDEX, GENERAL NOTES AND HIGHWAY STANDARDS
3	SUMMARY OF QUANTITIES
4-9	MAINTENANCE OF TRAFFIC SHEETS
10-11	PAVEMENT MARKING PLANS
12-27	BRIDGE REPAIR PLANS
28	TRAFFIC CONTROL AND PROTECTION FOR SIDEROADS, INTERSECTIONS AND DRIVEWAYS (TC-10)
29	RAISED REFLECTIVE PAVEMENT MARKERS (SNOW PLOW RESISTANT) (TC-11)
30	DISTRICT ONE PAVEMENT MARKINGS (TC-13)
31	TRAFFIC CONTROL AND PROTECTION AT TURN BAYS (TO REMAIN OPEN TO TRAFFIC) (TC-14)
32	PAVEMENT MARKING LETTERS AND SYMBOLS FOR TRAFFIC STAGING (TC16)
33	TEMPORARY INFORMATION SIGNING (TC22)

HIGHWAY STANDARDS

STD. NO.	TITLE
701426-03	LANE CLOSURE, MULTILANE, INTERMITTENT OR MOVING OPERATION FOR SPEEDS ≥ 45 MPH
701601-06	URBAN LANE CLOSURE, MULTILANE, 1W OR 2W WITH NONTRAVERSABLE MEDIAN
701801-04	LANE CLOSURE MULTILANE 1W OR 2W CROSSWALK OR SIDEWALK CLOSURE
701901-01	TRAFFIC CONTROL DEVICES
704001-06	TEMPORARY CONCRETE BARRIER
780001-02	TYPICAL PAVEMENT MARKINGS

GENERAL NOTES

BEFORE STARTING ANY EXCAVATION, THE CONTRACTOR SHALL CALL "J.U.L.I.E." AT 800-892-0123 OR 811 OR CALL "C.U.A.N." (CHICAGO UTILITY ALERT NETWORK) AT (312) 744-7000 FOR FIELD LOCATIONS OF BURIED ELECTRIC, TELEPHONE AND GAS FACILITIES. (48 HOUR NOTIFICATION IS REQUIRED).

THE CONTRACTOR SHALL COORDINATE CONSTRUCTION ACTIVITIES WITH UTILITY COMPANIES AND THE CITY OF CHICAGO AND THE VILLAGE OF BEDFORD PARK

THE CONTRACTOR WILL NOT BE ALLOWED TO SET UP A YARD OR FIELD OFFICE ON STATE PROPERTY WITHOUT WRITTEN PERMISSION FROM THE DEPARTMENT.

WHEN ARTIFICIAL LIGHTING IS USED IN NIGHT OPERATIONS THE CONTRACTOR SHALL EXERCISE THE UTMOST PRECAUTIONS IN PREVENTING ADVERSE VISIBILITY TO THE MOTORING PUBLIC AND ADJOINING RESIDENTIAL AREAS.

THE RESIDENT ENGINEER SHALL CONTACT THE TRAFFIC CONTROL SUPERVISOR AT (847) 705-4470 A MINIMUM 72 HOURS PRIOR TO BEGINNING WORK.

MATCH EXISTING PAVEMENT MARKINGS AT PROJECT LIMITS.

THE CONTRACTOR SHALL BE REQUIRED TO PROVIDE ACCESS TO ABUTTING PROPERTY AT ALL TIMES DURING THE CONSTRUCTION OF THIS PROJECT

DO NOT SCALE PLANS FOR CONSTRUCTION DIMENSIONS

THE CONTRACTOR SHALL TAKE NECESSARY PRECAUTIONS TO INSURE THAT NO DEBRIS WILL ENDANGER OR INTERFERE WITH THE RAILROAD BENEATH THE BRIDGE ACCORDING TO ARTICLE 107.12 OF THE STANDARD SPECIFICATIONS. THIS WORK WILL NOT BE PAID FOR SEPERATELY, BUT SHALL BE INCLUDED IN THE CONTRACT UNIT PRICE FOR THE APPROPRIATE PAY ITEM INVOLVED AND NO ADDITIONAL COMPENSATION WILL BE ALLOWED.

CONCRETE SUPERSTRUCTURE SHALL HAVE A SEVEN DAY MINIMUM CURE.

THERE IS EXISTING CONDUIT FOR FIBER OPTIC SIGNAL INTERCONNECT MOUNTED TO THE PARAPET ON THE WEST SIDE OF THE SOUTHBOUND BRIDGE. THE CONTRACTOR MUST PROTECT THIS CONDUIT AT ALL TIMES DURING CONSTRUCTION AND MUST USE EXTREME CARE WHILE REMOVING PORTIONS OF THE CONCRETE PARAPET FOR JOINT REPLACEMENT. THE CONDUIT MUST BE RIGIDLY SUPPORTED AT ALL TIMES IN ORDER TO MINIMIZE DEFLECTION AND MOVEMENT (SWAYING).

THE CITY OF CHICAGO HAS A 2" STREET LIGHTING CONDUIT EMBEDDED IN THE PARAPET ON THE WEST SIDE OF THE SOUTHBOUND BRIDGE AND ON THE EAST SIDE OF THE NORHTBOUND BRIDGE. CARE SHALL BE TAKEN NOT TO DAMEAGE CONDUIT DURING CONSTRUCTION.

REMOVAL OF EXISTING RAISED REFLECTIVE MARKER LENSES SHALL BE INCIDENTAL TO PAVEMENT MARKING REMOVAL AND WILL NOT BE PAID FOR SEPARARELY.

H:\Jobs\2009\20091023-02\CAD\Site\00\Dig\H16-sh1-gemnote.dgn 10/30/2009 10:08:41 AM

FILE NAME =	USER NAME = .USER.	DESIGNED - RS	REVISED -	<b>STATE OF ILLINOIS DEPARTMENT OF TRANSPORTATION</b>	<b>IL 50 (CICERO AVENUE) INDEX OF SHEETS AND GENERAL NOTES</b>	F.A.P. RTE.	SECTION	COUNTY	TOTAL SHEETS	SHEET NO.	
		DRAWN - EF	REVISED -			350	50-1 VB-1-BR	COOK	33	2	
	PLOT SCALE = 50.0000' / IN.	CHECKED -	REVISED -			CONTRACT NO. 60HT6					
	PLOT DATE = 10/30/2009	DATE - 10/23/09	REVISED -			SCALE:	SHEET NO. OF SHEETS	STA.	TO STA.	ILLINOIS FED. AID PROJECT	

SUMMARY OF QUANTITIES

URBAN  
100% STATE

CODE NUMBER	ITEM	UNIT	TOTAL QUANTITY	SFTY-2A STATE
50102400	CONCRETE REMOVAL	CU YD	77	77
50300255	CONCRETE SUPERSTRUCTURE	CU YD	78	78
50300300	PROTECTIVE COAT	SQ YD	111	111
50800205	REINFORCEMENT BARS, EPOXY COATED	POUND	15,040	15,040
50800515	BAR SPLICERS	EACH	74	74
52000110	PREFORMED JOINT STRIP SEAL	FOOT	159	159
52000340	NEOPRENE EXPANSION JOINT 4"	FOOT	54	54
67000400	ENGINEER'S FIELD OFFICE, TYPE A	CAL MO	6	6
67100100	MOBILIZATION	L SUM	1	1
70101800	TRAFFIC CONTROL AND PROTECTION, (SPECIAL)	L SUM	1	1
70301000	WORK ZONE PAVEMENT MARKING REMOVAL	SQ FT	2,589	2,589
70400100	TEMPORARY CONCRETE BARRIER	FOOT	988	988
70400200	RELOCATE TEMPORARY CONCRETE BARRIER	FOOT	988	988
* 78000100	THERMOPLASTIC PAVEMENT MARKING - LETTERS AND SYMBOLS	SQ FT	36	36
* 78000200	THERMOPLASTIC PAVEMENT MARKING -LINE 4"	FOOT	1,728	1,728
* 78000400	THERMOPLASTIC PAVEMENT MARKING -LINE 6"	FOOT	140	140
* 78100300	REPLACEMENT REFLECTOR	EACH	50	50
78300100	PAVEMENT MARKING REMOVAL	SQ FT	682	682
X0322256	TEMPORARY INFORMATION SIGNING	SQ FT	102	102
X0322933	SILICONE JOINT SEALER, 2.5"	FOOT	51	51
X0320087	POLYMER CONCRETE	CU FT	5.3	5.3
X0323076	SILICONE JOINT SEALER, 1 3/4"	FOOT	53	53
X0323077	SILICONE JOINT SEALER, 2 3/4"	FOOT	51	51
X0325305	STRUCTURAL REPAIR OF CONCRETE (DEPTH EQUAL TO OR LESS THAN 5 INCHES)	SQ FT	447	447
X0325775	WET REFLECTIVE TEMPORARY TAPE, TYPE III, 4 INCH	FOOT	6,964	6,964
X0325837	WET REFLECTIVE TEMPORARY TAPE TYPE III, 6 INCH	FOOT	394	394
X0325842	WET REFLECTIVE TEMPORARY TAPE, TYPE III, LETTERS AND SYMBOLS	SQ FT	73	73
X0325737	TEMPORARY TRAFFIC SIGNAL TIMING	EACH	2	2
Z0010605	CLEANING DRAINAGE SYSTEM	L SUM	1	1
Z0030240	IMPACT ATTENUATORS, TEMPORARY (NON-REDIRECTIVE), TEST LEVEL 2	EACH	2	2
Z0030340	IMPACT ATTENUATORS, RELOCATE (NON-REDIRECTIVE), TEST LEVEL 2	EACH	2	2
Z0048665	RAILROAD PROTECTIVE LIABILITY INSURANCE	L SUM	1	1
Z0073200	TEMPORARY SHORING AND CRIBBING	EACH	4	4

\* DENOTES SPECIALTY ITEM

H:\job\2009\20090303-02 CAD\Site\00\DI60HT6-ehf-500.dgn  
 11/2/2009 10:55 PM

FILE NAME *	USER NAME = USER	DESIGNED - RS	REVISED -	<b>STATE OF ILLINOIS DEPARTMENT OF TRANSPORTATION</b>	<b>IL 50 (CICERO AVENUE) SUMMARY OF QUANTITIES</b>			F.A.P. RTE.	SECTION	COUNTY	TOTAL SHEETS	TOTAL SHEET NO.	
		DRAWN - EF	REVISED -					350	50-1 VB-1-BR	COOK	33	3	
		CHECKED -	REVISED -					CONTRACT NO. 60HT6					
		DATE - 10/23/09	REVISED -					ILLINOIS FED. AID PROJECT					
	PLOT SCALE = 50.0000' / IN.				SCALE:	SHEET NO.	OF	SHEETS	STA.	TO STA.			
	PLOT DATE = 11/2/2009												

Rev.

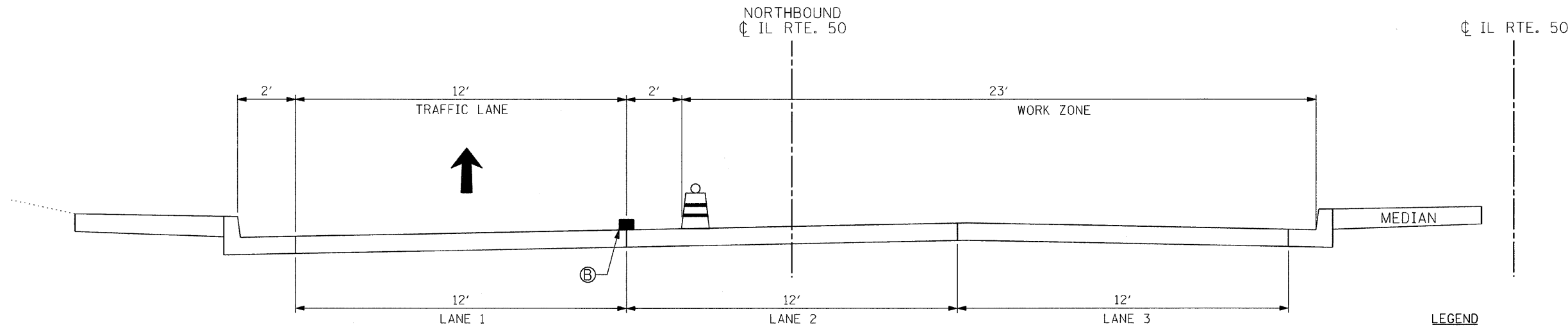

**MAINTENANCE OF TRAFFIC  
IL-50 OVER BRC RR  
BRIDGE JOINT RECONSTRUCTION- STAGE 1  
(LOOKING SOUTH)**

- LEGEND**
- DRUM WITH STEADY BURN LIGHT
  - PAVEMENT MARKING
  - SOLID YELLOW LINE, TAPE TYPE III, 4"
  - SOLID WHITE LINE, TAPE TYPE III, 4"

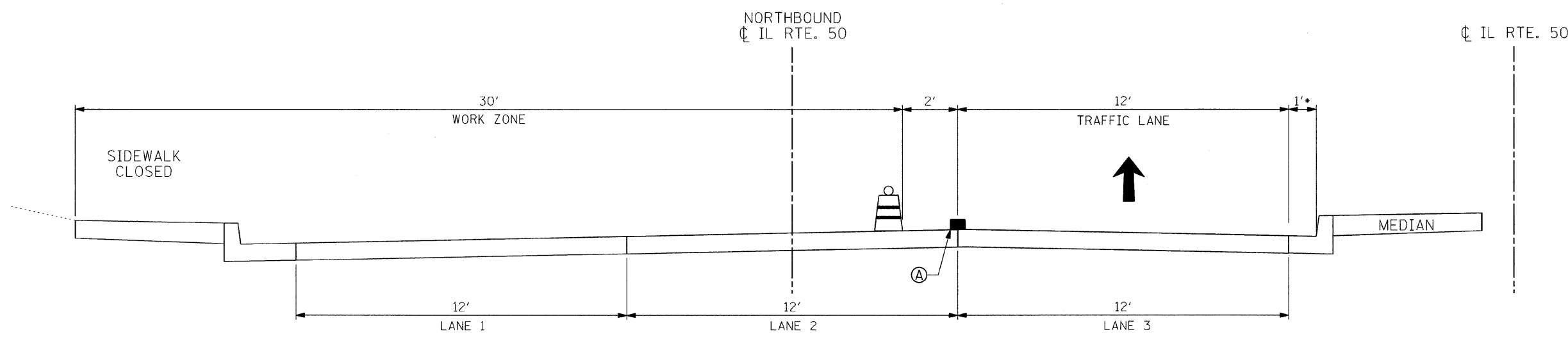

**MAINTENANCE OF TRAFFIC  
IL-50 OVER BRC RR  
BRIDGE JOINT RECONSTRUCTION- STAGE 2  
(LOOKING SOUTH)**

• VARIES 1' TO 3.42'  
STA. 142+61 TO 143+46

M:\b2008\2009\1023\02\cadd\site\00\0160116-sh1-typical.dgn  
 10/22/2009 10:54:48 AM

FILE NAME =	USER NAME = .USER.	DESIGNED - RS	REVISED -	<b>STATE OF ILLINOIS DEPARTMENT OF TRANSPORTATION</b>	<b>IL 50 (CICERO AVENUE) NORTHBOUND TYPICAL SECTIONS</b>		F.A.P. RTE. 350	SECTION 50-1 VB-1-BR	COUNTY COOK	TOTAL SHEETS 33	SHEET NO. 4	
	PLOT SCALE = 50.0045' / IN.	DRAWN - EF	REVISED -		SCALE:	SHEET NO. 1 OF 2 SHEETS	STA.	TO STA.	CONTRACT NO. 60H76			
	PLOT DATE = 10/22/2009	CHECKED -	REVISED -		ILLINOIS FED. AID PROJECT							
		DATE - 10/23/09	REVISED -									



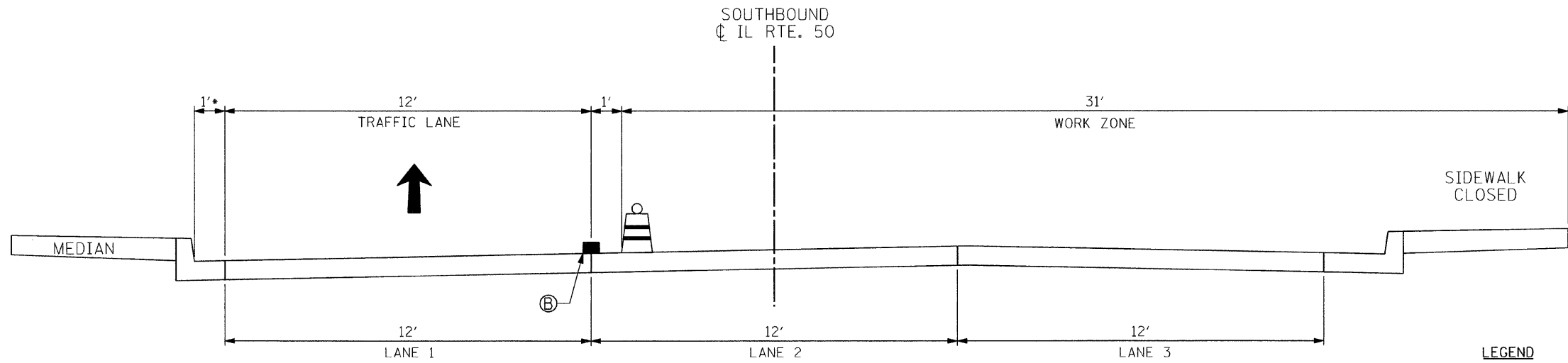

CL IL RTE. 50



\* VARIES 1' TO 3.42'  
STA. 142+61 TO 143+46

**MAINTENANCE OF TRAFFIC  
IL-50 OVER BRC RR  
BRIDGE JOINT RECONSTRUCTION- STAGE 1  
(LOOKING SOUTH)**

**LEGEND**

-  DRUM WITH STEADY BURN LIGHT
-  PAVEMENT MARKING
-  SOLID YELLOW LINE, TAPE TYPE III, 4"
-  SOLID WHITE LINE, TAPE TYPE III, 4"

CL IL RTE. 50

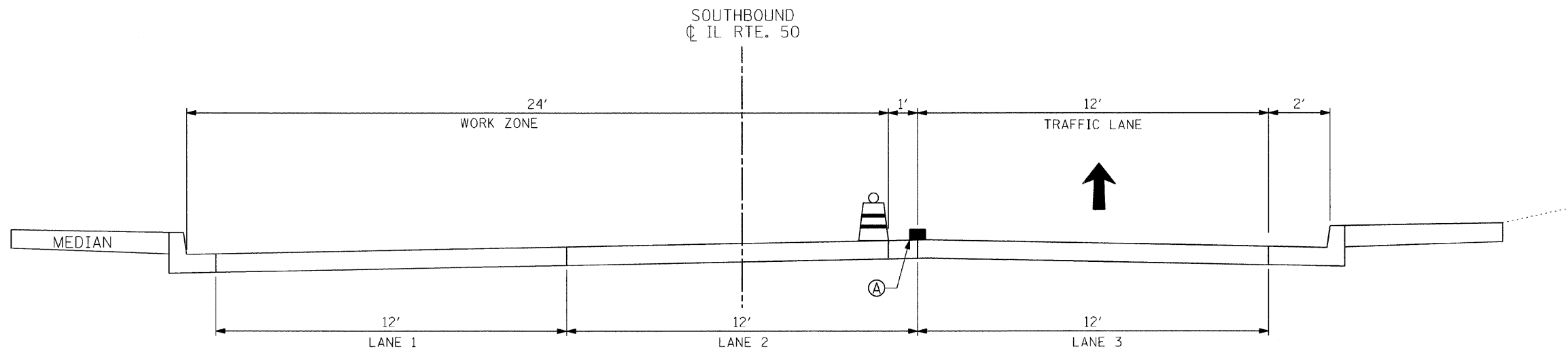

**MAINTENANCE OF TRAFFIC  
IL-50 OVER BRC RR  
BRIDGE JOINT RECONSTRUCTION- STAGE 2  
(LOOKING SOUTH)**

P:\10852009\20083023-02\cadd\site\00\10852009\10852009.dgn  
 10/22/2009 10:54:50 AM

FILE NAME =	USER NAME = .USER.	DESIGNED - RS	REVISED -	<b>STATE OF ILLINOIS DEPARTMENT OF TRANSPORTATION</b>	<b>IL 50 (CICERO AVENUE) SOUTHBOUND TYPICAL SECTIONS</b>		F.A.P. RTE. 350	SECTION 50-1 VB-1-BR	COUNTY COOK	TOTAL SHEETS 33	SHEET NO. 5	
PLDT SCALE = 50.0045' / IN.	CHECKED - EF	REVISED -	REVISED -		SCALE:	SHEET NO. 2 OF 2 SHEETS	STA.	TO STA.	ILLINOIS FED. AID PROJECT			
PLDT DATE = 10/22/2009	DATE - 10/23/09	REVISED -	REVISED -		CONTRACT NO. 60H76							

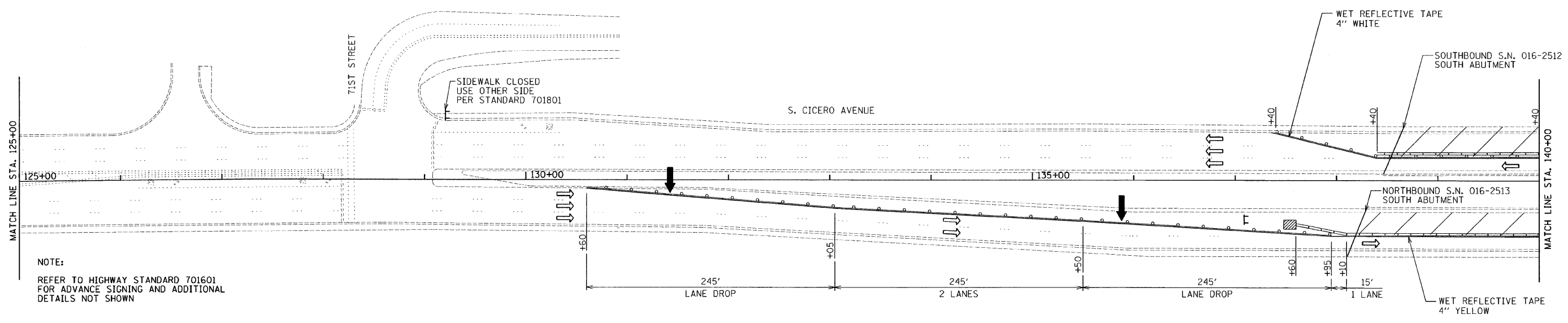

NOTE:  
REFER TO HIGHWAY STANDARD 701601  
FOR ADVANCE SIGNING AND ADDITIONAL  
DETAILS NOT SHOWN

- CONSTRUCTION WORK ZONE
- DIRECTION OF TRAFFIC
- TEMPORARY CONCRETE BARRIER
- IMPACT ATTENUATOR TEMPORARY
- FLASHING ARROW BOARD
- TYPE III BARRICADE
- BARRICADE OR DRUM  
50' CTC ON TANGENTS  
20' CTC IN TAPER

NOTE:  
FIBER OPTIC CABLES ARE ATTACHED TO THE WEST SIDE OF THE  
SOUTHBOUND BRIDGE (SN 016-2512) FOR TRAFFIC SIGNAL INTERCONNECT.  
THERE ARE DRAIN PIPES ATTACHED TO THE BOTTOM OF THE DECK AND  
DIAPHRAGMS. THERE MAY BE ELECTRICAL CONDUIT IN THE DECK FOR  
THE LIGHTING ON THE BRIDGE.  
USE DIRECTION INDICATOR BARRICADES IN LANE CLOSURE TAPERS

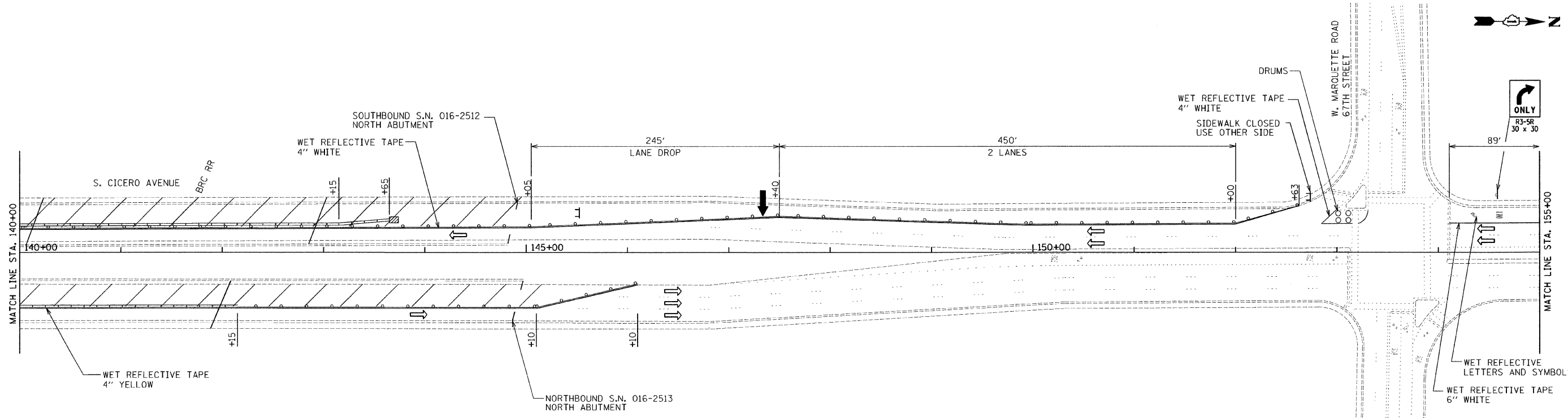
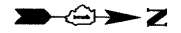

P:\Jobs\2009\20090223-02\cod\site\00\DIR\76-sht+st+cg\01.dgn  
 10/22/2009 10:58:04 AM

FILE NAME =	USER NAME = .USER.	DESIGNED - RS	REVISED -	<b>STATE OF ILLINOIS DEPARTMENT OF TRANSPORTATION</b>	<b>IL 50 (CICERO AVENUE) MAINTENANCE OF TRAFFIC STAGE 1</b>			F.A.P. RTE. 350	SECTION 50-1 VB-1-BR	COUNTY COOK	TOTAL SHEETS 33	SHEET NO. 6
	PLOT SCALE = 50.0045' / IN.	CHECKED - EF	REVISED -		SCALE: 50	SHEET NO. 1 OF 4 SHEETS	STA. TO STA.	CONTRACT NO. 60H76				
	PLOT DATE = 10/22/2009	DATE - 10/23/09	REVISED -		ILLINOIS FED. AID PROJECT							

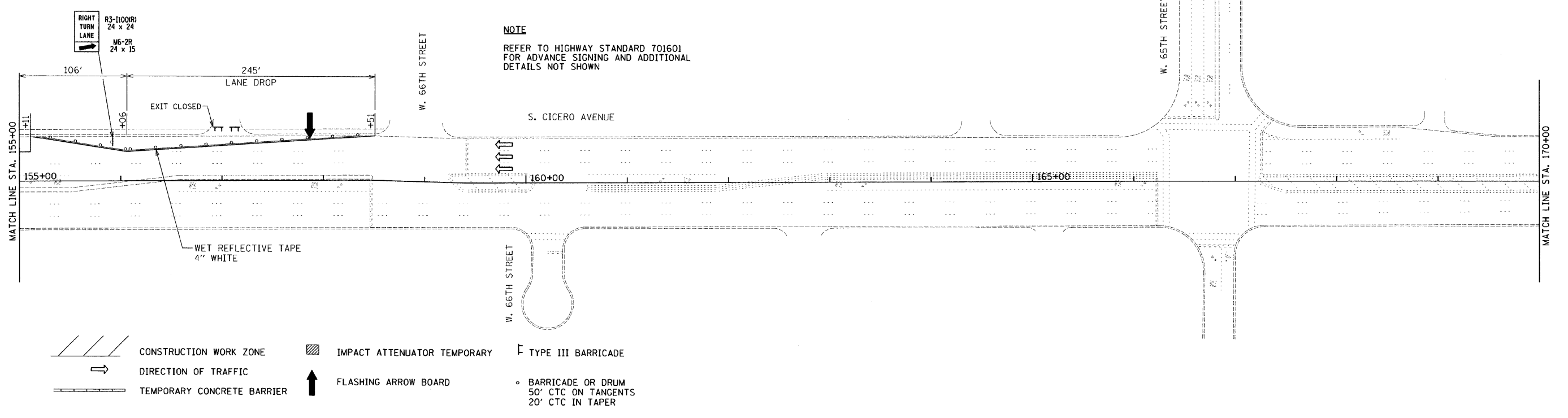
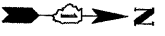

**NOTE**  
 REFER TO HIGHWAY STANDARD 701601  
 FOR ADVANCE SIGNING AND ADDITIONAL  
 DETAILS NOT SHOWN

- CONSTRUCTION WORK ZONE
- DIRECTION OF TRAFFIC
- TEMPORARY CONCRETE BARRIER
- IMPACT ATTENUATOR TEMPORARY
- FLASHING ARROW BOARD
- TYPE III BARRICADE
- BARRICADE OR DRUM  
50' CTC ON TANGENTS  
20' CTC IN TAPER

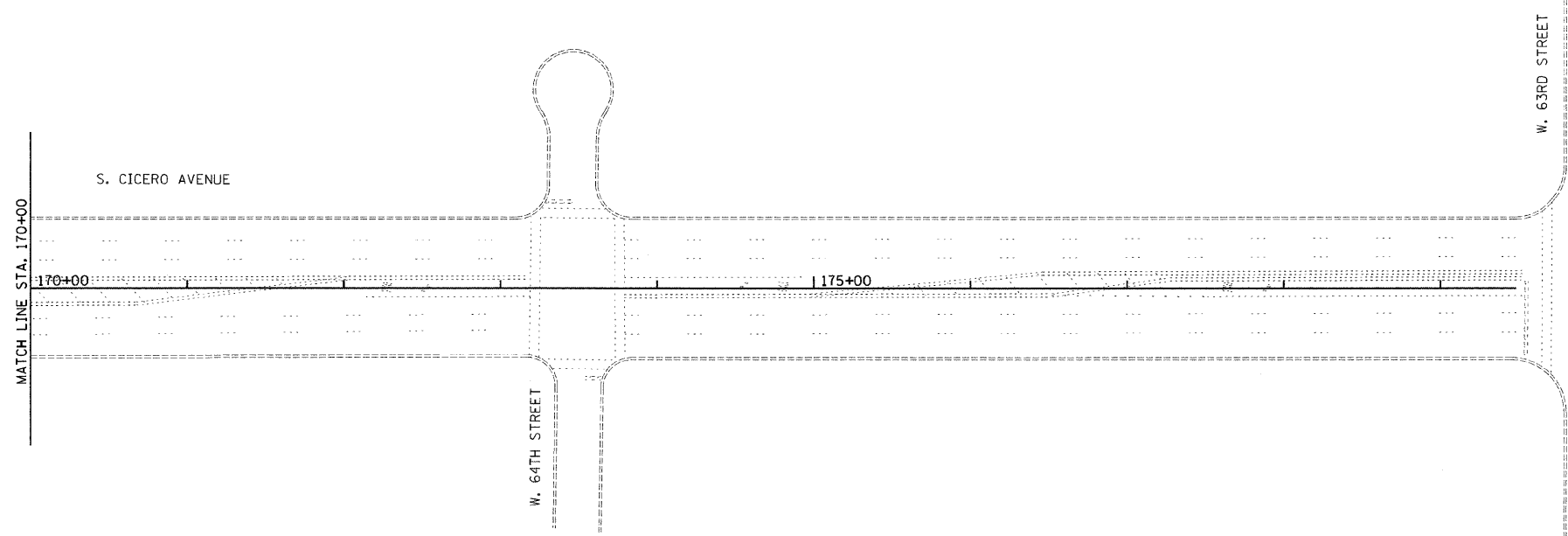

P:\10522009\20093023-02\cadd\site\00\DieOff76-sht+st09e02.dgn  
 10/22/2009 10:58:09 AM

FILE NAME =	USER NAME = .USER.	DESIGNED - RS	REVISED -
		DRAWN - EF	REVISED -
	PLOT SCALE = 50.0057' / IN.	CHECKED -	REVISED -
	PLOT DATE = 10/22/2009	DATE - 10/23/09	REVISED -

**STATE OF ILLINOIS  
 DEPARTMENT OF TRANSPORTATION**

<b>IL 50 (CICERO AVENUE)    MAINTENANCE OF TRAFFIC STAGE 1</b>			
SCALE: 50	SHEET NO. 2 OF 4 SHEETS	STA. TO STA.	

F.A.P. RTE.	SECTION	COUNTY	TOTAL SHEETS	SHEET NO.
350	50-1 VB-1-BR	COOK	33	7
CONTRACT NO. 60H76				
ILLINOIS FED. AID PROJECT				

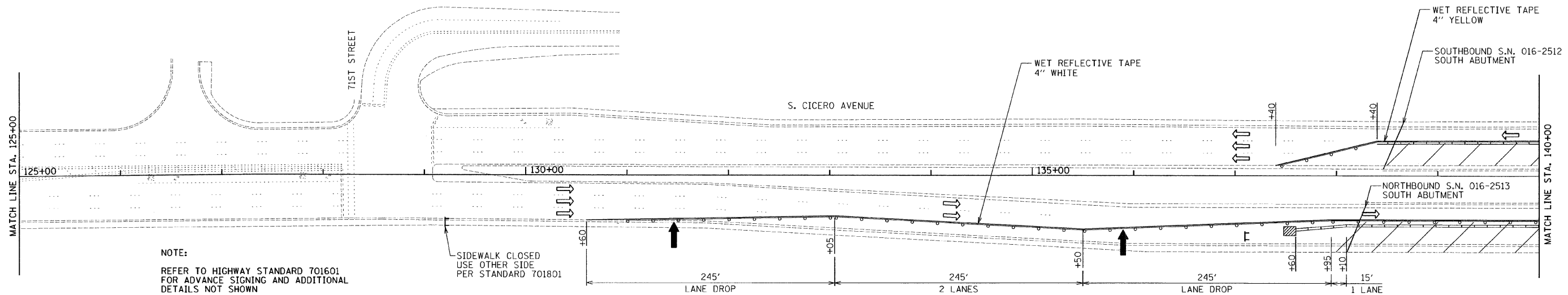

NOTE:  
REFER TO HIGHWAY STANDARD 701601  
FOR ADVANCE SIGNING AND ADDITIONAL  
DETAILS NOT SHOWN

SIDEWALK CLOSED  
USE OTHER SIDE  
PER STANDARD 701801

- CONSTRUCTION WORK ZONE
- DIRECTION OF TRAFFIC
- TEMPORARY CONCRETE BARRIER
- IMPACT ATTENUATOR TEMPORARY
- FLASHING ARROW BOARD
- TYPE III BARRICADE
- BARRICADE OR DRUM  
50' CTC ON TANGENTS  
20' CTC IN TAPER

NOTE:  
FIBER OPTIC CABLES ARE ATTACHED TO THE WEST SIDE OF THE  
SOUTHBOUND BRIDGE (SN 016-2512) FOR TRAFFIC SIGNAL INTERCONNECT.  
THERE ARE DRAIN PIPES ATTACHED TO THE BOTTOM OF THE DECK AND  
DIAPHRAGMS. THERE MAY BE ELECTRICAL CONDUIT IN THE DECK FOR  
THE LIGHTING ON THE BRIDGE.  
USE DIRECTION INDICATOR BARRICADES IN LANE CLOSURE TAPERS

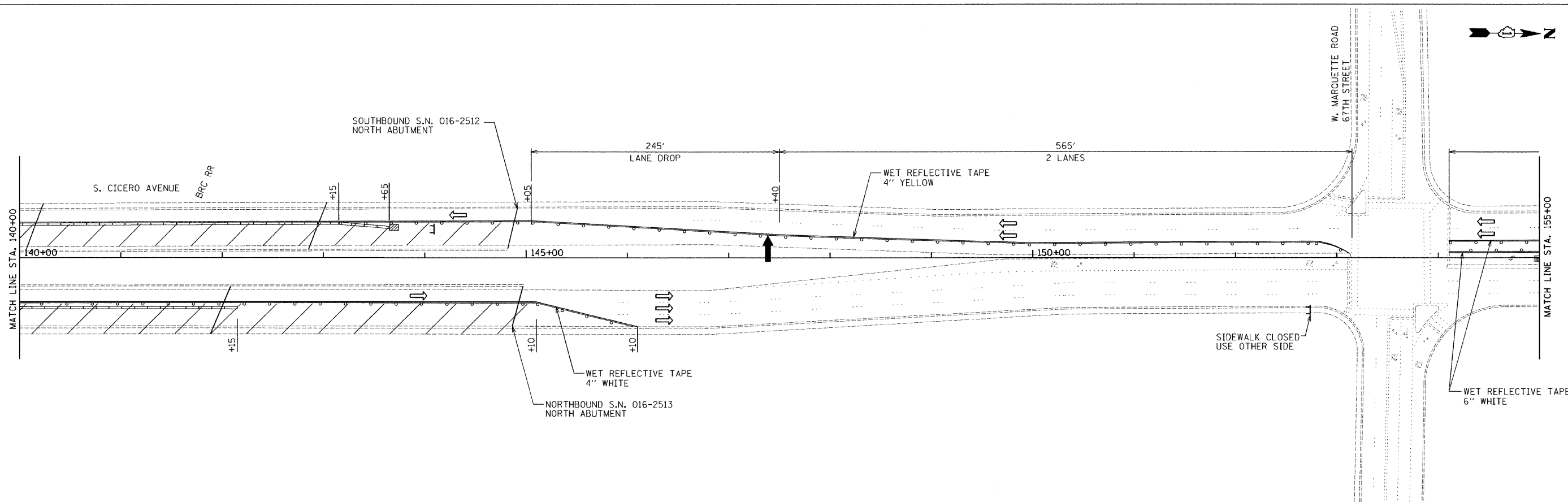

P:\Jobs\2009\20091223-02\cadd\site\00\1160H76-sht1-s\stage201.dgn  
 10/22/2009 10:58:14 AM

FILE NAME =	USER NAME = USER	DESIGNED - RS	REVISED -
		DRAWN - EF	REVISED -
	PLOT SCALE = 50.0045' / IN.	CHECKED -	REVISED -
	PLOT DATE = 10/22/2009	DATE - 10/23/09	REVISED -

**STATE OF ILLINOIS  
DEPARTMENT OF TRANSPORTATION**

**IL 50 (CICERO AVENUE)  
MAINTENANCE OF TRAFFIC STAGE 2**

SCALE: 50 SHEET NO. 3 OF 4 SHEETS STA. TO STA.

F.A.P. RTE.	SECTION	COUNTY	TOTAL SHEETS	SHEET NO.
350	50-1 VB-1-BR	COOK	33	8
CONTRACT NO. 60H76			ILLINOIS FED. AID PROJECT	



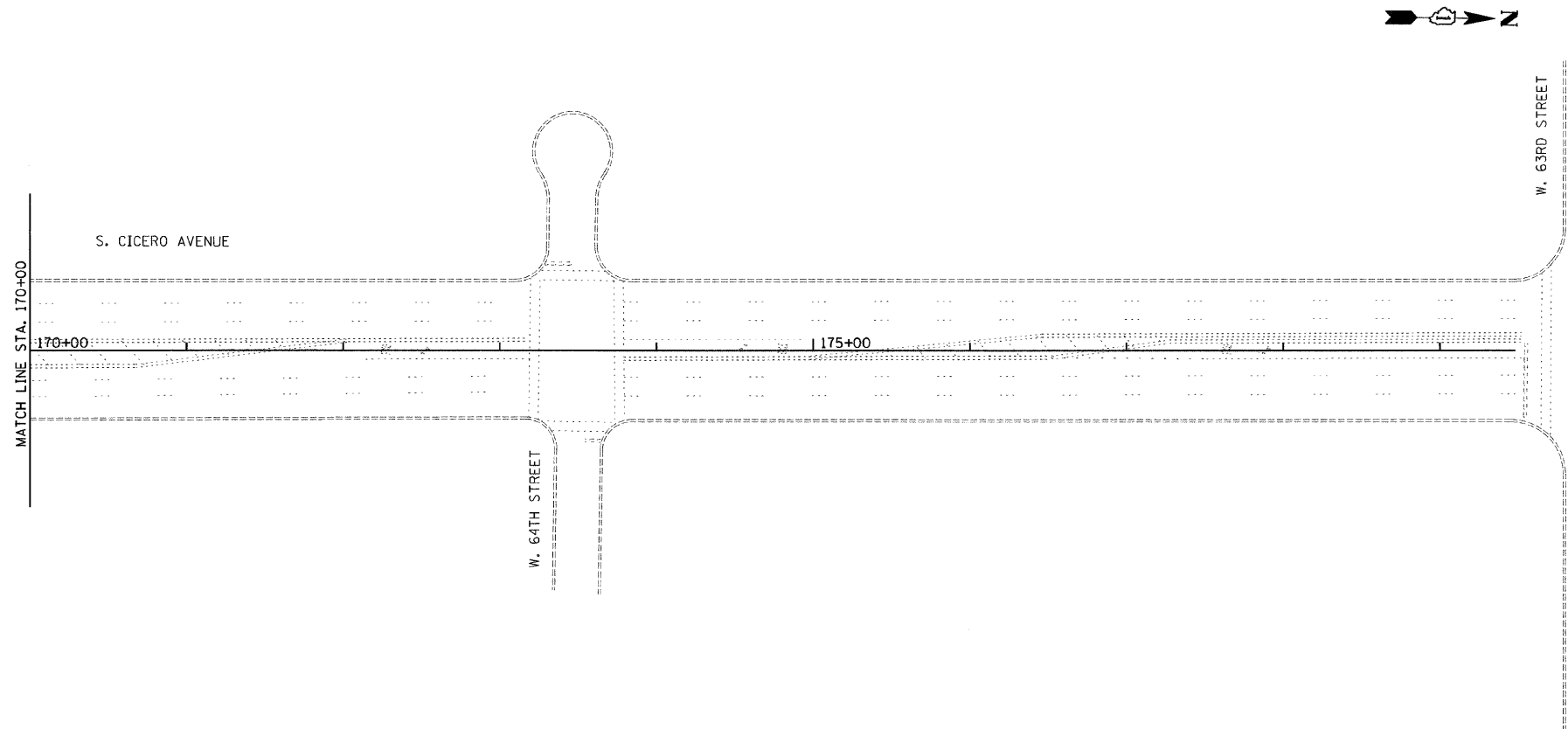
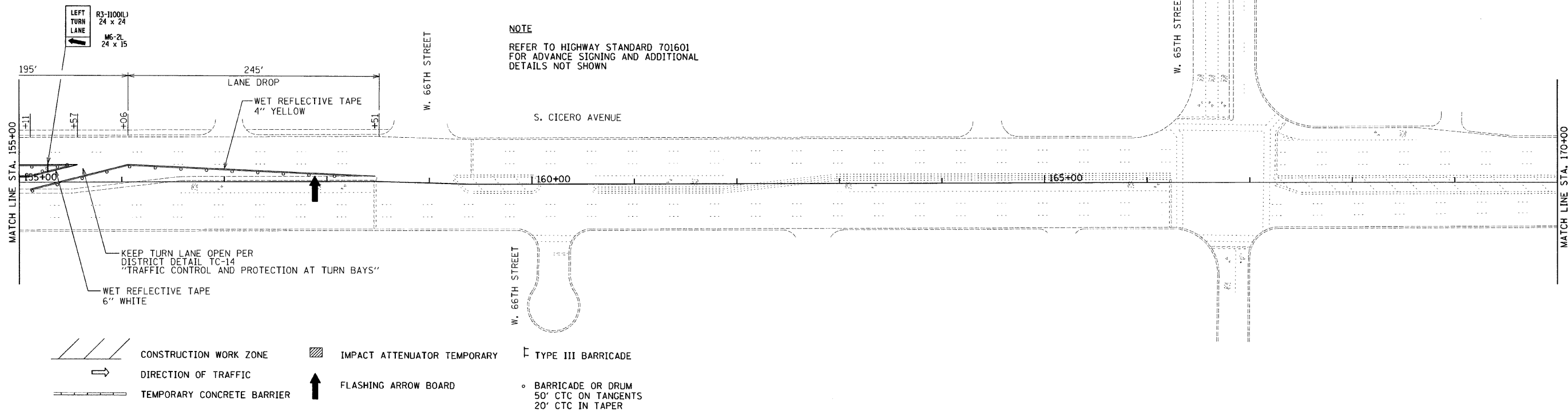

P:\\_0822009\20091023-02\cdd\site\00\Di60H76-eh1-s'ope202.dgn  
 10/22/2009 10:58:55 AM

FILE NAME =	USER NAME = USER.	DESIGNED - RS	REVISED -
		DRAWN - EF	REVISED -
		CHECKED -	REVISED -
		DATE - 10/23/09	REVISED -

**STATE OF ILLINOIS**  
**DEPARTMENT OF TRANSPORTATION**

**IL 50 (CICERO AVENUE)**  
**MAINTENANCE OF TRAFFIC STAGE 2**

SCALE: 50      SHEET NO. 4 OF 4 SHEETS      STA.      TO STA.

F.A.P. RTE.	SECTION	COUNTY	TOTAL SHEETS	SHEET NO.
350	50-1 VB-1-BR	COOK	33	9
CONTRACT NO. 60H76			ILLINOIS FED. AID PROJECT	



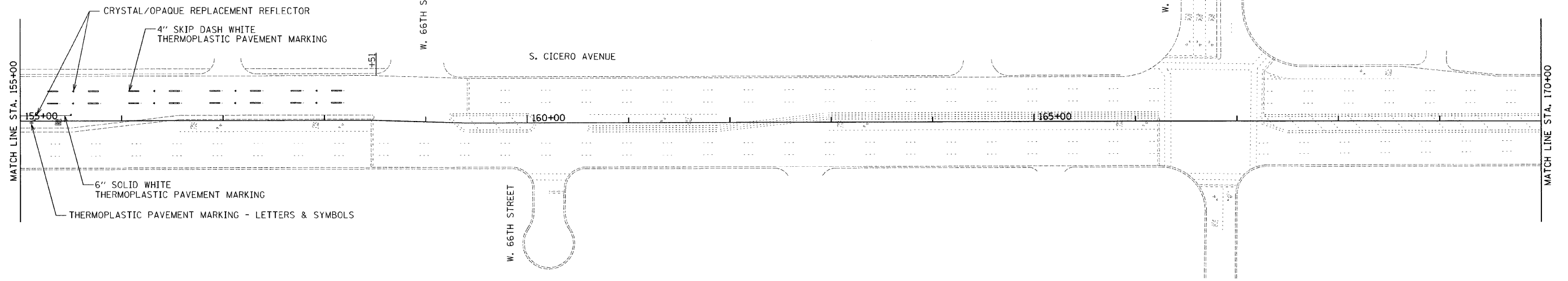

NOTE:  
 REPAIR OR REPLACE RPM'S THAT ARE DAMAGED OR REMOVED DURING TRAFFIC STAGING  
 REFER TO IDOT DISTRICT 1 STANDARD TC-11 AND TC-13  
 FOR ADDITIONAL DETAILS NOT SHOWN

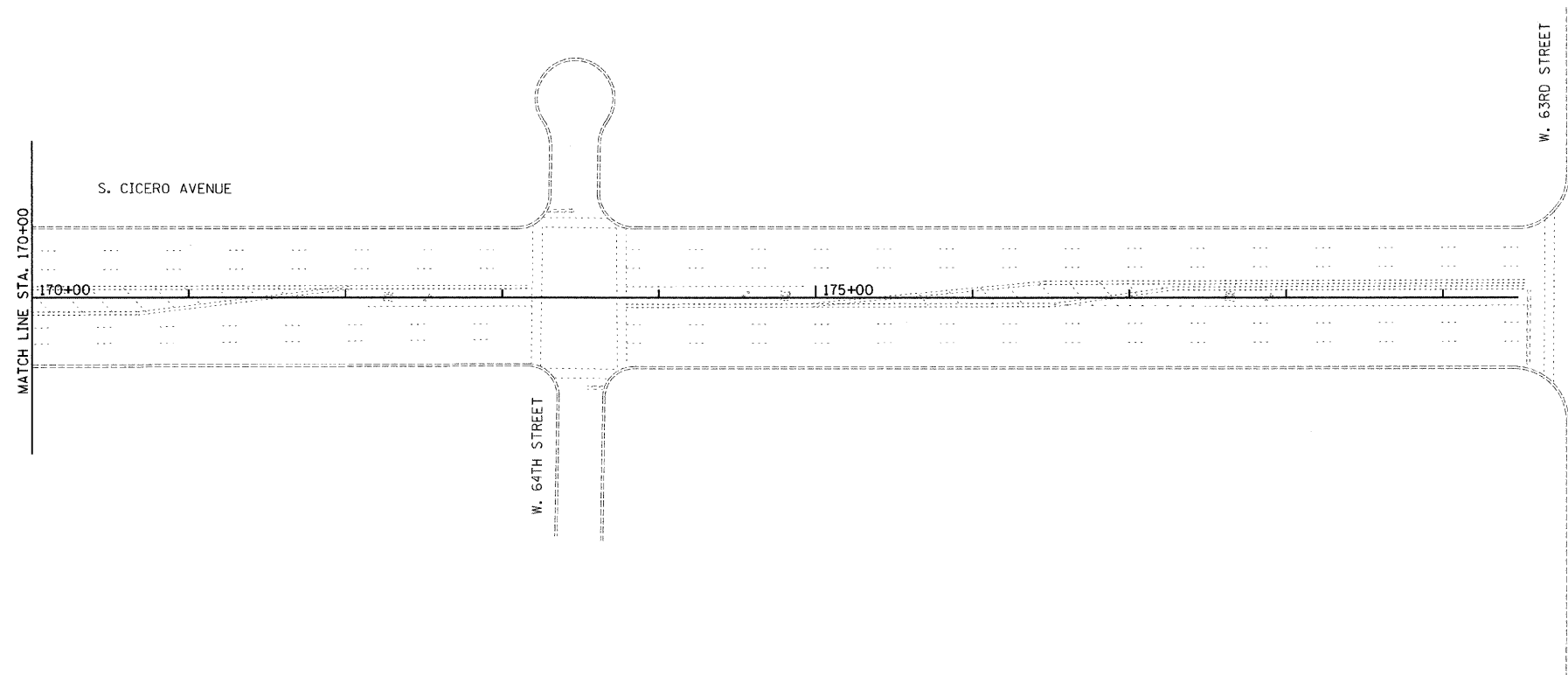

H:\isb\3009\20091023-02\CAD\Site\00\DI60RT6-sft1-pmk102.dgn  
 11/2/2009 2:32:31 PM

FILE NAME =	USER NAME = .USER.	DESIGNED - RS	REVISED -	<b>STATE OF ILLINOIS DEPARTMENT OF TRANSPORTATION</b>	<b>IL 50 (CICERO AVENUE) PAVEMENT MARKING PLAN</b>		F.A.P. RTE.	SECTION	COUNTY	TOTAL SHEETS	SHEET NO.
	PLOT SCALE = 50.0011' / IN.	DRAWN - EF	REVISED -				350	50-1 VB-1-BR	COOK	33	11
	PLOT DATE = 11/2/2009	CHECKED -	REVISED -				CONTRACT NO. 60H76			ILLINOIS FED. AID PROJECT	
	DATE - 10/23/09	REVISED -		SCALE: 50	SHEET NO. 2 OF 4 SHEETS	STA. TO STA.					

FAP ROUTE NO.	SECTION	COUNTY	TOTAL SHEETS	SHEET NO.	SHEET NO. 1 OF 16 SHEETS
350	50-1 VB-1-BR	Cook	33	12	
FED. RD. DIST.	ELLINGS	FED. AID PROJECT-			

Contract # 60H76

**SCOPE OF WORK**

1. Remove and replace expansion joints at abutments, Southbound Piers 3 & 7 and Northbound Pier 4.
2. Repair concrete at Southbound Piers 3 & 7 and Northbound Pier 4.
3. Clean the existing drainage system.

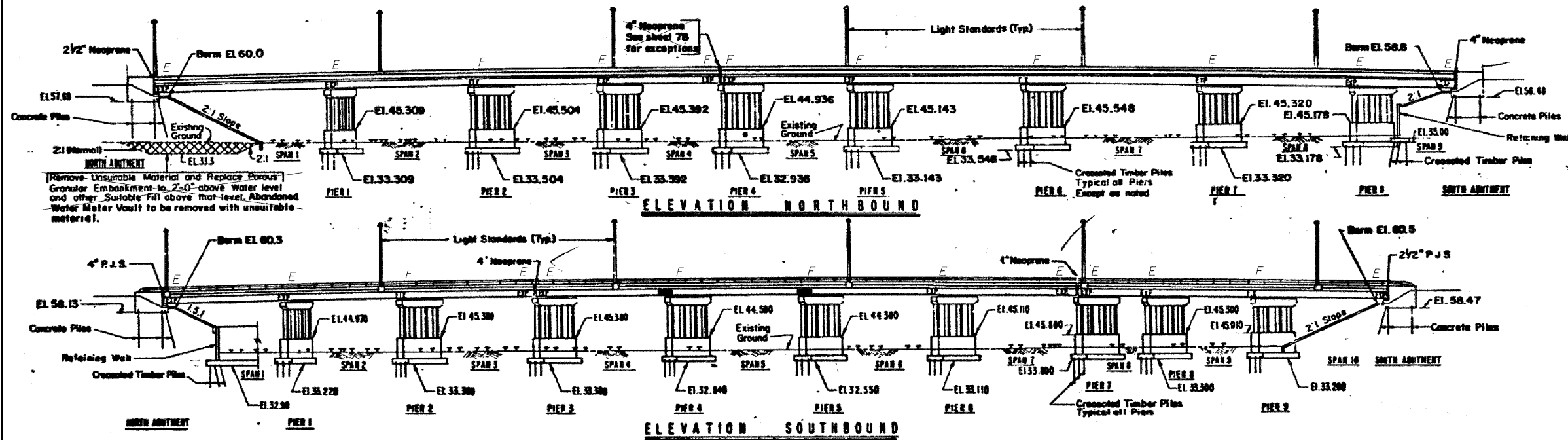
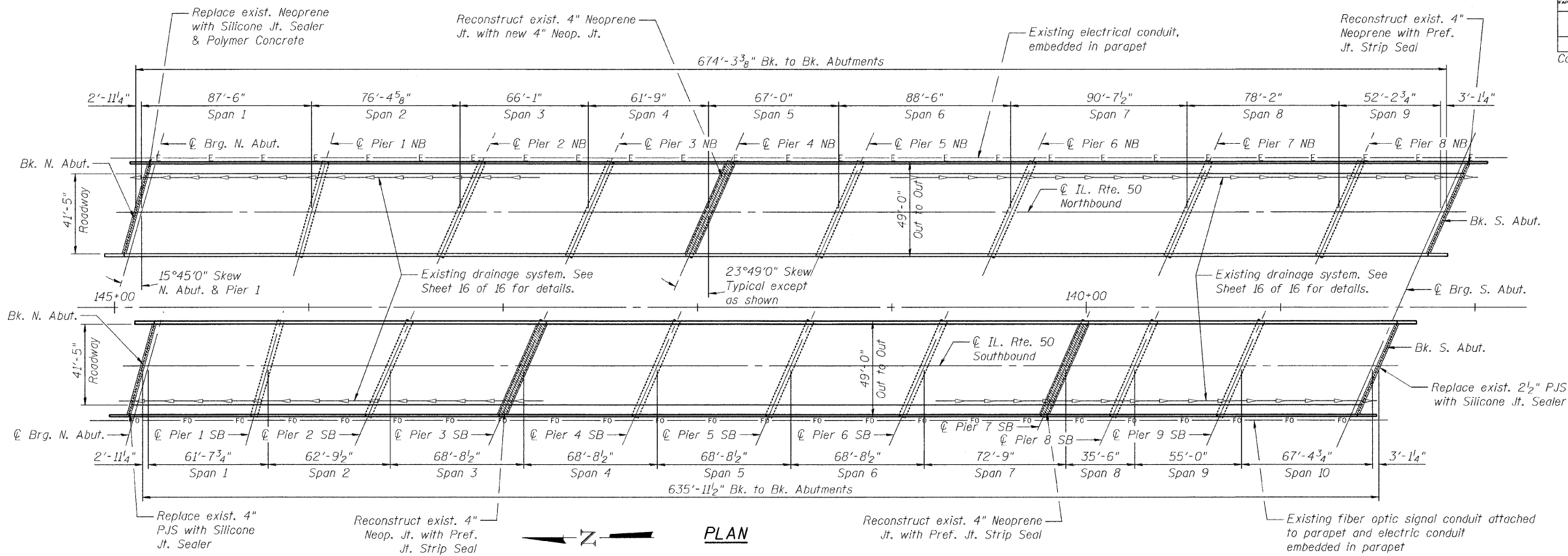

DESIGNED	E.E.J.
CHECKED	J.A.Z.
DRAWN	E.E.J.
CHECKED	J.A.Z.

GENERAL PLAN & ELEVATION  
 IL 50 (CICERO AVE) OVER BRC R.R.  
 F.A.P. 350, SECTION 50-1 VB-1-BR  
 COOK COUNTY

S.N. 016-2512 (S.B.), 016-2513 (N.B.)  
 DATE: 10-23-09

GRAEF  
 CHICAGO ILLINOIS



Contract # 60H76

### GENERAL NOTES

- Reinforcement bars shall conform to the requirements of ASTM A 706 Gr. 60. See Special Provisions.
- Reinforcement bars designated (E) shall be epoxy coated.
- Plan dimensions and details relative to existing plans are subject to nominal construction variations. The Contractor shall field verify existing dimensions and details affecting new construction and make necessary approved adjustments prior to construction or ordering of materials. Such variations shall not be cause for additional compensation for a change in scope of the work, however, the Contractor will be paid for the quantity actually furnished at the unit price bid for the work.
- At SB Piers 3 and 7, NB Pier 4 and the NB South Abutment, existing guardrail and/or railings are attached to the parapets in areas where concrete is to be removed. The cost to disconnect and reconnect the guardrail and railings shall be included in the cost of Concrete Removal. If the embedded anchorages for the railings are damaged during concrete removal, the Contractor shall furnish and install new anchorages to match the existing and the cost shall also be included in the cost of Concrete Removal.
- Existing reinforcement bars extending into the removal area shall be cleaned, straightened and incorporated into the new construction. Any reinforcement bars that are damaged during concrete removal shall be replaced with an approved bar splicer or anchorage system. Cost included with Concrete Removal.
- The Contractor shall use extreme care during concrete removal so as not to damage the PPC I-Beam.
- The deck surface shall have its final finish tined according to Article 420.09(e)(1) of the Standard Specifications. Cost included with Concrete Superstructures.
- Joint openings shall be adjusted according to Article 520.04 of the Std. Specs. when the deck is poured at an ambient temperature other than 50°F.

### TOTAL BILL OF MATERIAL

Item	Unit	Total	SB	NB
Concrete Removal	CU YD	77	42	35
Concrete Superstructure	CU YD	78.0	42.8	35.2
Protective Coat	SQ YD	111	60	51
Reinforcement Bars, Epoxy Coated	POUND	15,040	8,400	6,640
Bar Splicers	EACH	74	40	34
Prefomed Joint Strip Seal	FOOT	159	106	53
Neoprene Expansion Joint 4"	FOOT	54	-	54
Silicone Joint Sealer, 2.5"	FOOT	51	-	51
Polymer Concrete	CU FT	5.3	-	5.3
Silicone Joint Sealer, 1 <sup>3</sup> / <sub>4</sub> "	FOOT	53	53	-
Silicone Joint Sealer, 2 <sup>3</sup> / <sub>4</sub> "	FOOT	51	51	-
Structural Repair of Concrete (Depth Equal to or Less than 5 Inches)	SQ FT	447	316	131
Cleaning Drainage System	L SUM	1	-	-
Temporary Shoring and Cribbing	EACH	4	3	1

### INDEX OF SHEETS

- GENERAL PLAN & ELEVATION
- GENERAL NOTES & TOTAL BILL OF MATERIAL
- CONSTRUCTION STAGING
- EXPANSION JOINTS, SB ABUTMENTS & NB NORTH ABUTMENT
- EXPANSION JOINT, NB SOUTH ABUTMENT
- EXPANSION JOINTS, SB PIERS 3 & 7
- PREFORMED JOINT STRIP SEAL
- EXPANSION JOINT, NB PIER 4
- CONTINUOUS SEAL 4" NEOPRENE EXPANSION JOINTS
- EXPANSION JOINT BILLS OF MATERIAL
- SB PIER 3 REPAIRS
- SB PIER 7 REPAIRS
- NB PIER 4 REPAIRS
- BAR SPLICER ASSEMBLY DETAILS
- RAILING
- DRAINAGE SYSTEM

DESIGNED	E.E.J.
CHECKED	J.A.Z.
DRAWN	E.E.J.
CHECKED	J.A.Z.

GENERAL NOTES &  
TOTAL BILL OF MATERIAL  
IL 50 (CICERO AVE) OVER BRC R.R.  
F.A.P. 350, SECTION 50-1 VB-1-BR  
COOK COUNTY  
S.N. 016-2512 (S.B.), 016-2513 (N.B.)  
DATE: 10-23-09  
GRAEF  
CHICAGO ILLINOIS

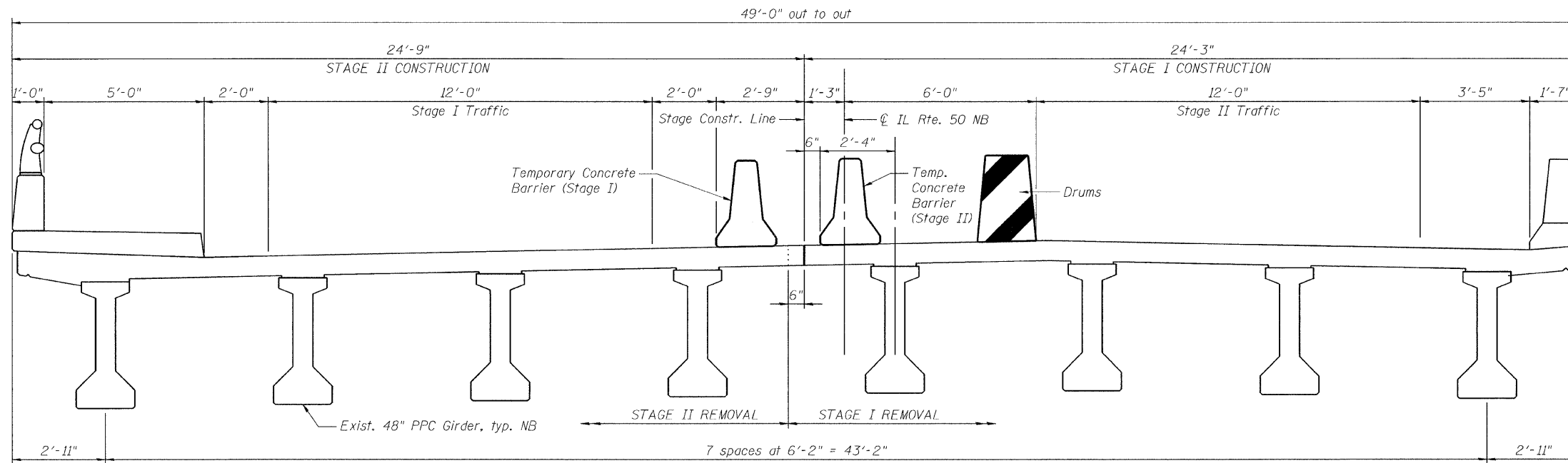

**NORTHBOUND DECK CROSS SECTION**  
(Looking South)

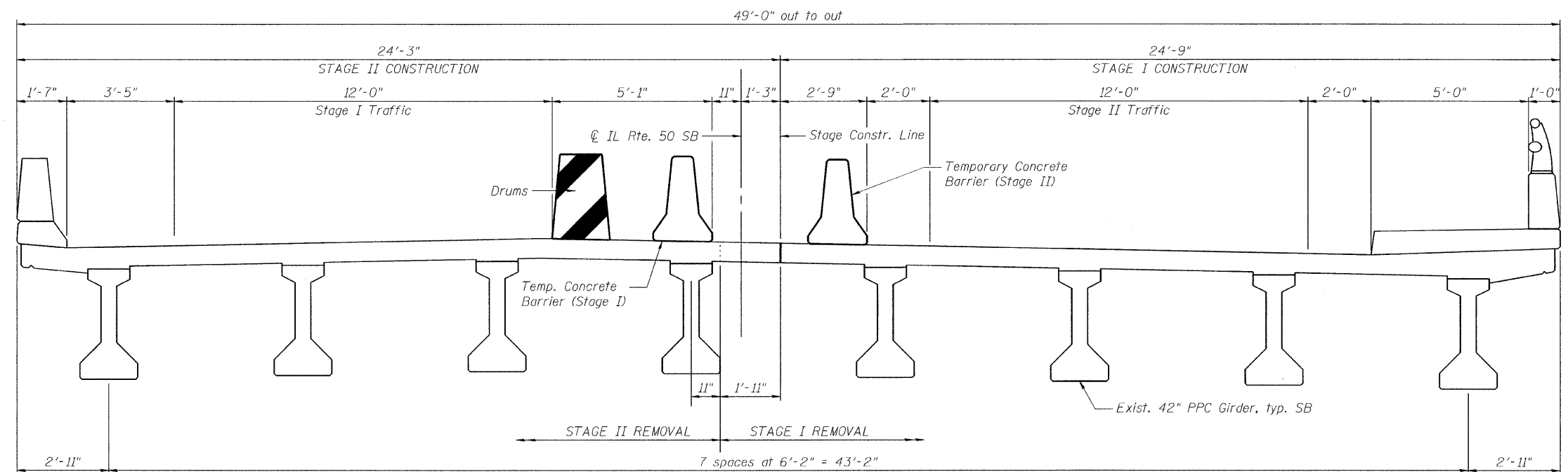

**SOUTHBOUND DECK CROSS SECTION**  
(Looking South)

DESIGNED	E.E.J.
CHECKED	J.A.Z.
DRAWN	E.E.J.
CHECKED	J.A.Z.

**CONSTRUCTION STAGING**  
**IL 50 (CICERO AVE) OVER BRC R.R.**  
**F.A.P. 350, SECTION 50-1 VB-1-BR**  
**COOK COUNTY**

S.N. 016-2512 (S.B.), 016-2513 (N.B.)  
 DATE: 10-23-09  
 GRAEF  
 CHICAGO ILLINOIS

P&P ROUTE NO.	SECTION	COUNTY	TOTAL SHEETS	SHEET NO.	SHEET NO. 4 OF 16 SHEETS
350	50-1 VB-1-BR	Cook	33	15	
FED. ROAD DIST.		ILLINOIS		FED. AID PROJECT	

Contract # 60H76

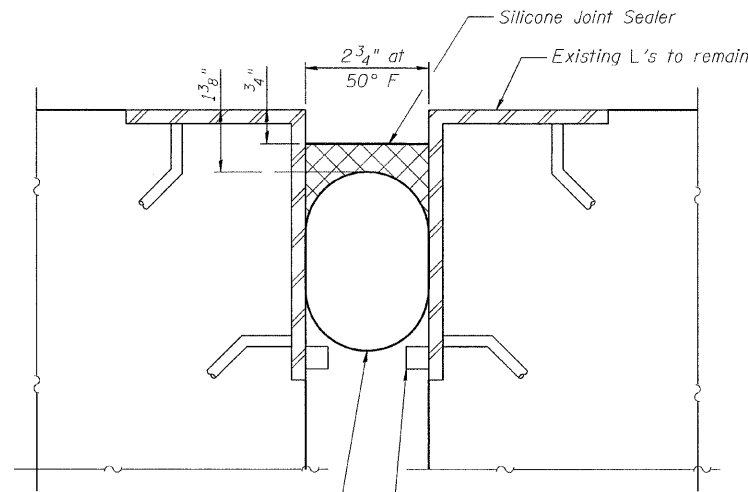

Backer rod having a diameter 25% greater than joint opening at the time of installation.

**SB, N. ABUTMENT EXPANSION JOINT**

(Horiz. dimensions at Rt. L's)

Note: Remove existing preformed joint sealer.  
Cost included with Silicone Joint Sealer, 2 3/4"

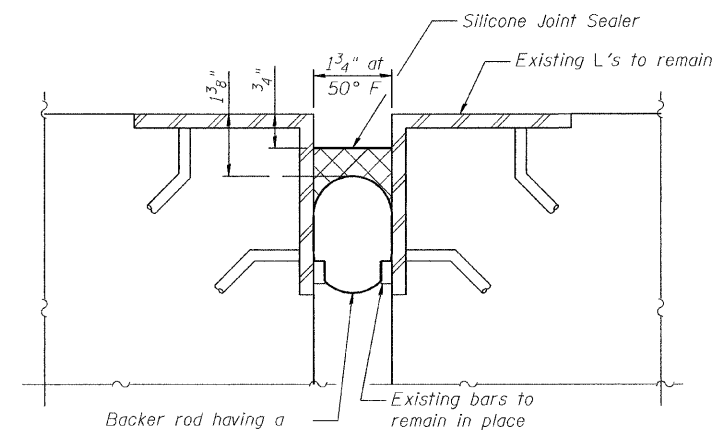

Backer rod having a diameter 25% greater than joint opening at the time of installation.

**SB, S. ABUTMENT EXPANSION JOINT**

(Horiz. dimensions at Rt. L's)

Note: Remove existing preformed joint sealer.  
Cost included with Silicone Joint Sealer, 1 3/4"

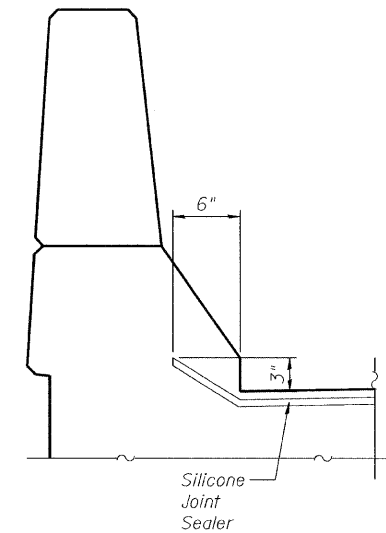

**SB END TREATMENT**

Polymer Concrete Nosing.  
Dimensions to match dimensions of existing neoprene expansion joint.

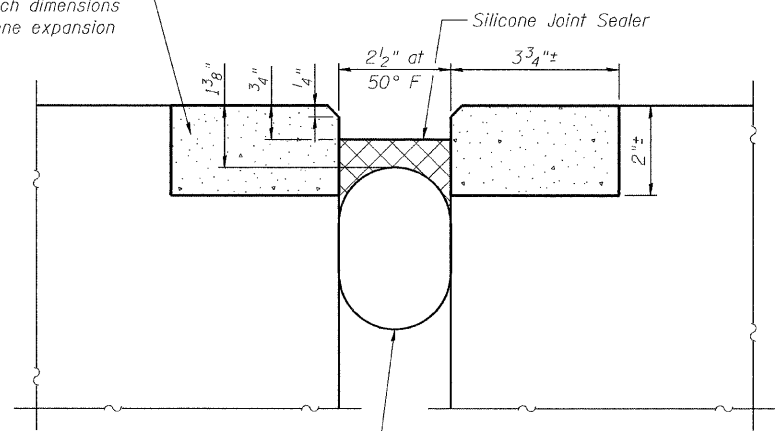

Backer rod having a diameter 25% greater than joint opening at the time of installation.

**NB, N. ABUTMENT EXPANSION JOINT**

(Horiz. dimensions at Rt. L's)

Note: Remove existing neoprene expansion joint.  
Cost included with Silicone Joint Sealer, 2.5"

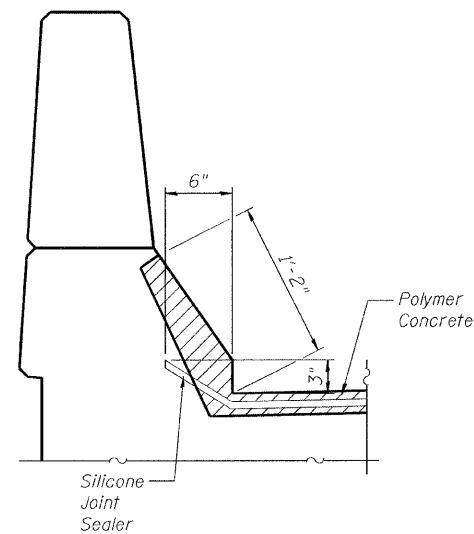

**NB END TREATMENT**

Notes:  
1. Joint opening widths are based on original plans. Contractor must verify dimensions.

**BILL OF MATERIAL**

Item	Unit	Quantity
Silicone Joint Sealer, 2.5"	Foot	51
Polymer Concrete	Cu. Ft.	5.3
Silicone Joint Sealer, 1 3/4"	Foot	53
Silicone Joint Sealer, 2 3/4"	Foot	51

DESIGNED	E.E.J.
CHECKED	J.A.Z.
DRAWN	E.E.J.
CHECKED	J.A.Z.

EXPANSION JOINTS  
SB ABUTMENTS & NB NORTH ABUTMENT  
IL 50 (CICERO AVE) OVER BRC R.R.  
F.A.P. 350, SECTION 50-1 VB-1-BR  
COOK COUNTY  
  
S.N. 016-2512 (S.B.), 016-2513 (N.B.)  
DATE: 10-23-09  
GRAEF  
CHICAGO  
ILLINOIS

MAP ROUTE NO.	SECTION	COUNTY	TOTAL SHEETS	SHEET NO.
350	50-1 VB-1-BR	Cook	33	16
FED. ROAD DIST.		ILLINOIS	FED. AID PROJECT-	

Contract # 60H76

SHEET NO. 5 OF 16 SHEETS

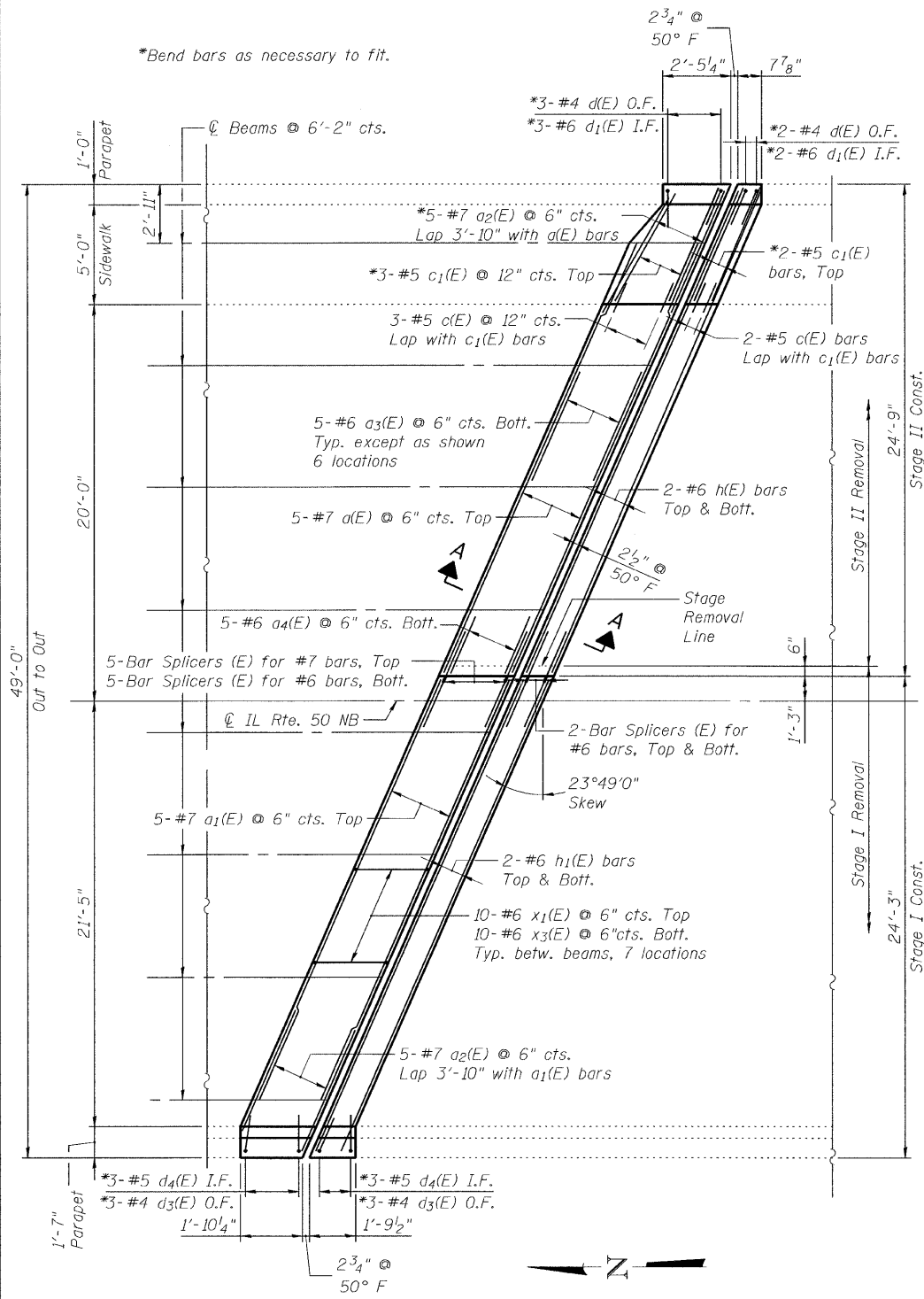

**EXP. JOINT PLAN AT NB, SOUTH ABUTMENT**

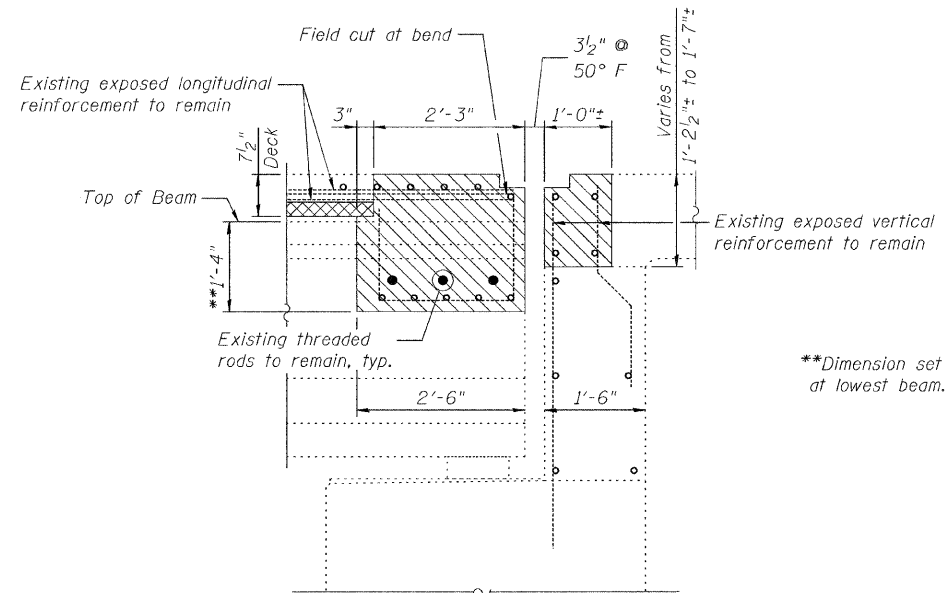

**SECTION A-A  
CONCRETE REMOVAL @ NB, S. ABUT.**  
(Horiz. dimensions at Rt. L's)

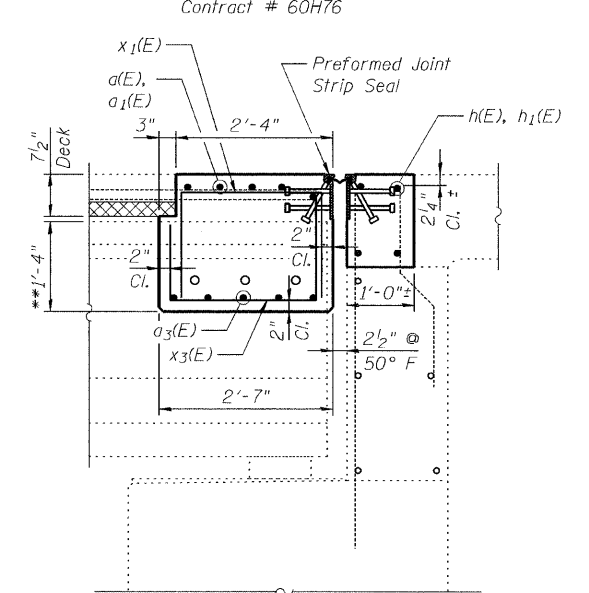

**SECTION A-A  
CONCRETE REPLACEMENT @ NB, S. ABUT.**  
(Horiz. dimensions at Rt. L's)

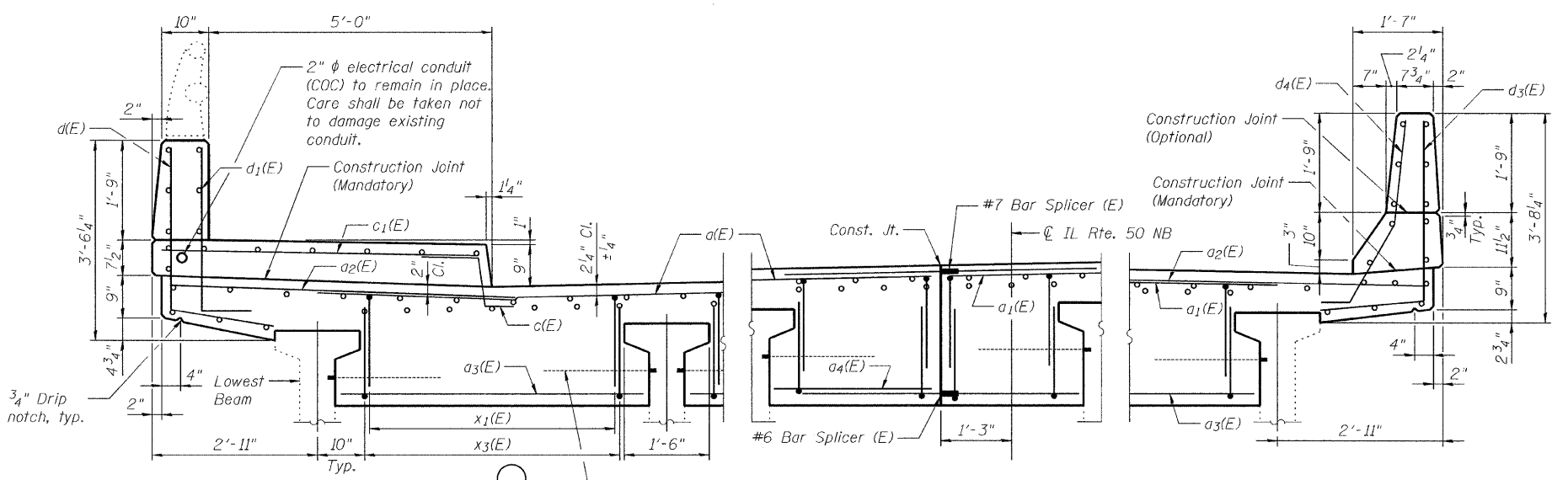

**SIDEWALK SECTION (Looking South)**      **CENTER SECTION (Looking South)**      **CURB SECTION (Looking South)**

DESIGNED	E.E.J.
CHECKED	J.A.Z.
DRAWN	E.E.J.
CHECKED	J.A.Z.

- Notes:
- Existing reinforcement shall be cleaned and incorporated into the new construction.
  - See Sheet 10 of 16 for Bill of Material.

- LEGEND**
- Concrete Removal
  - Exist. PPC Deck Plank, 2 1/2 inch thick

**EXPANSION JOINT  
NB SOUTH ABUTMENT  
IL 50 (CICERO AVE) OVER BRC R.R.  
F.A.P. 350, SECTION 50-1 VB-1-BR  
COOK COUNTY**

S.N. 016-2512 (S.B.), 016-2513 (N.B.)  
DATE: 10-23-09  
GRAEF  
CHICAGO ILLINOIS



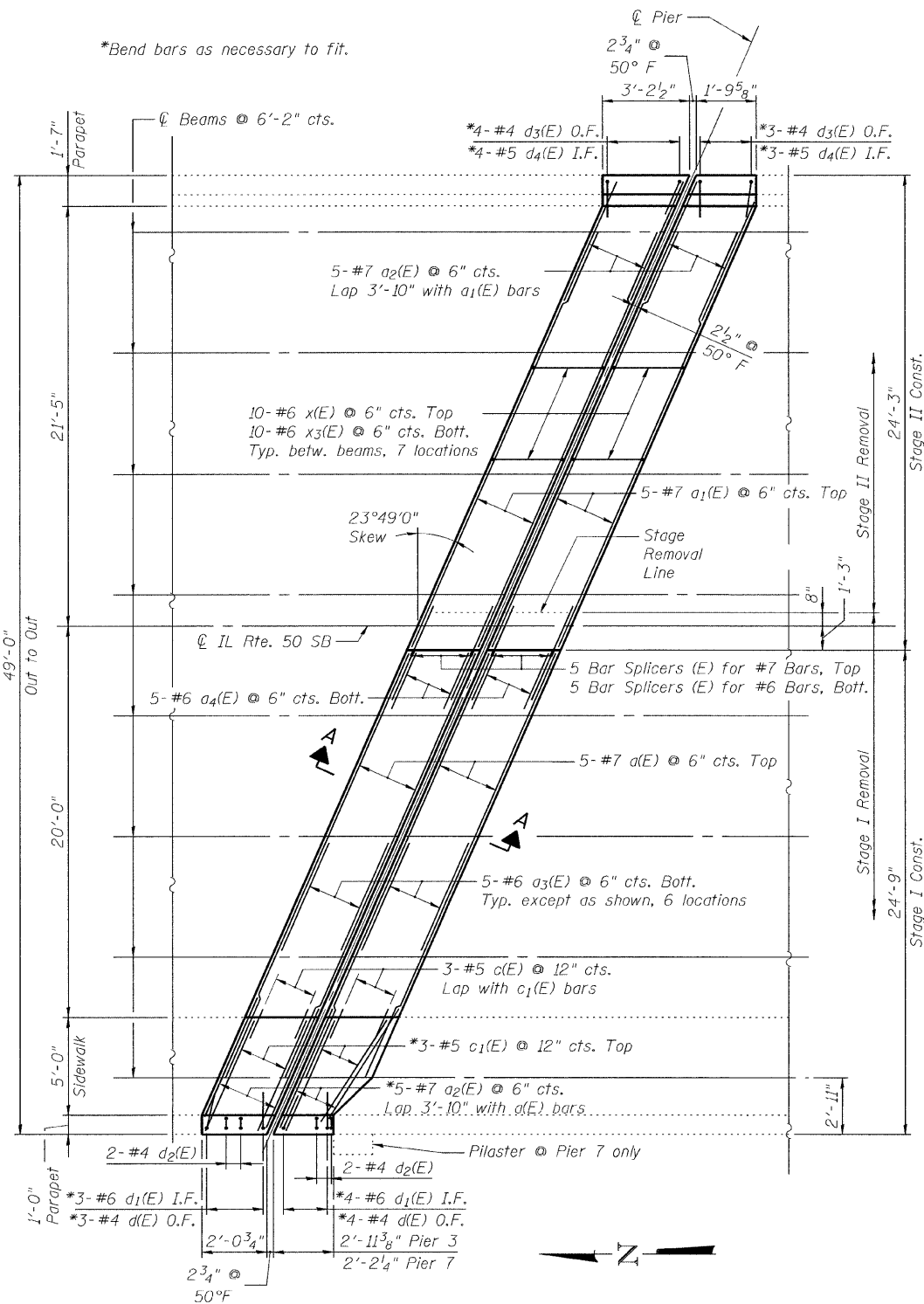

**EXP. JOINT PLAN AT SB PIER 3 & SB PIER 7**

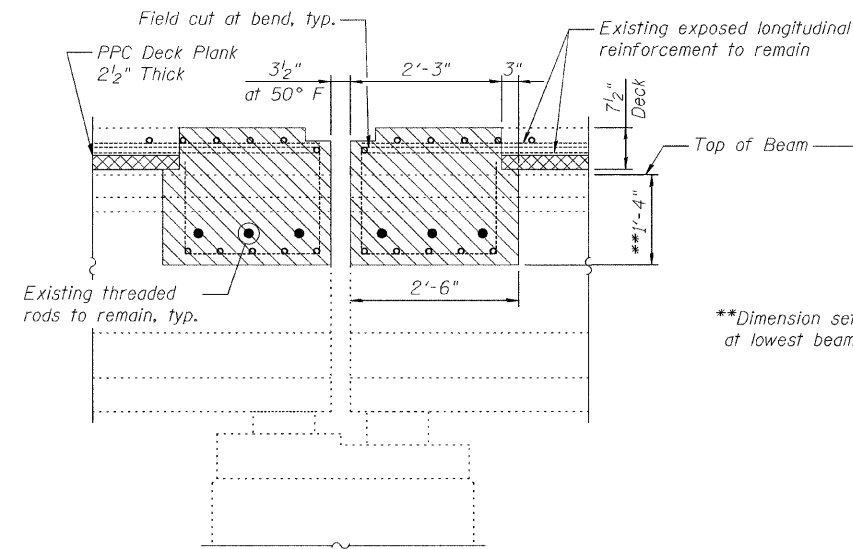

**SECTION A-A  
CONCRETE REMOVAL @ SB PIER 3 & SB PIER 7**  
(Horiz. dimensions at Rt. L's)

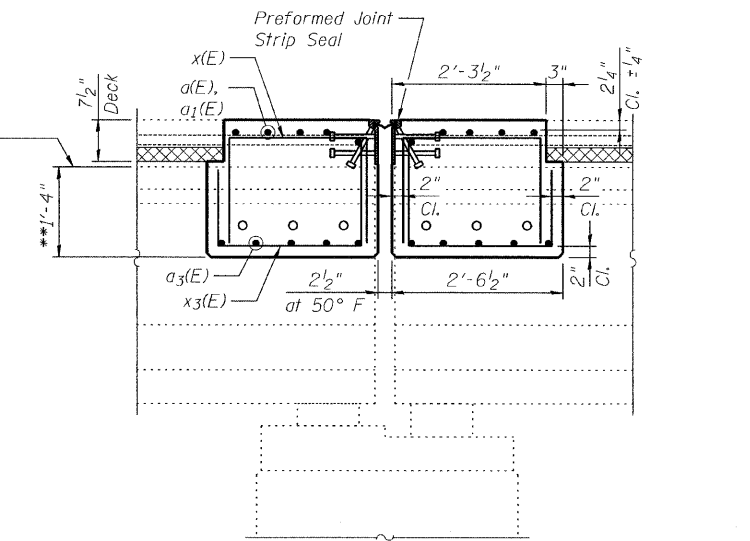

**SECTION A-A  
CONCRETE REPLACEMENT @ SB PIER 3 & SB PIER 7**  
(Horiz. dimensions at Rt. L's)

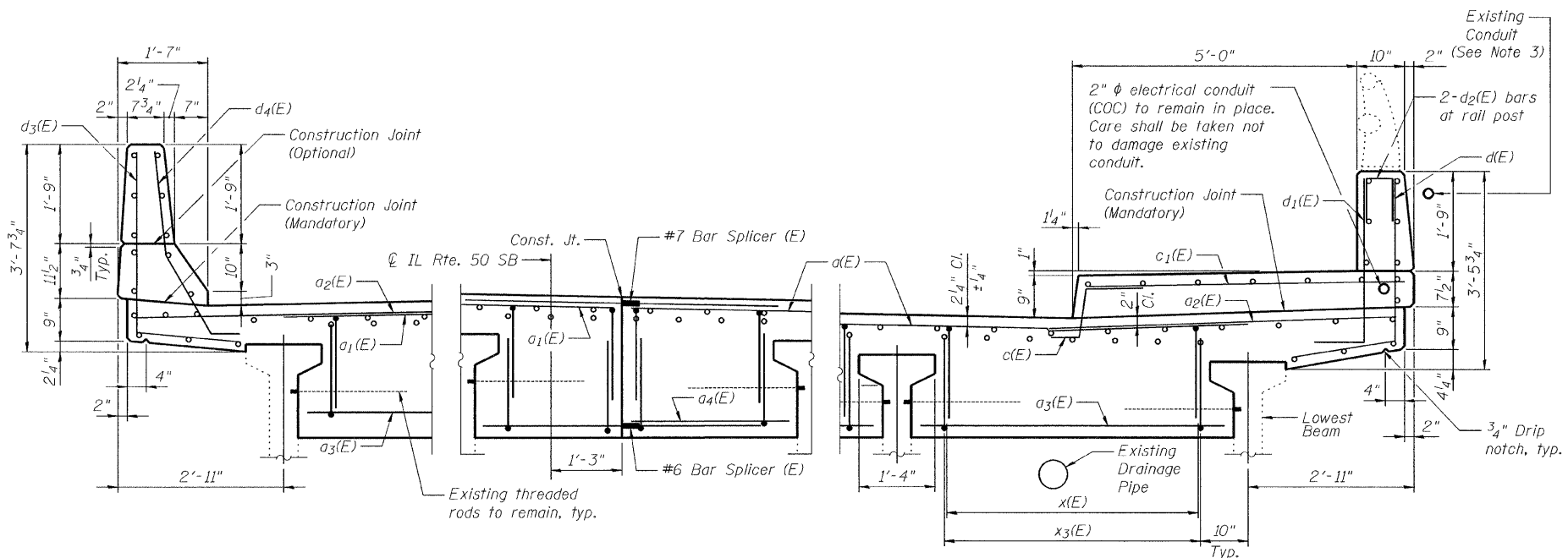

**CURB SECTION**  
(Looking South)

**CENTER SECTION**  
(Looking South)

**SIDEWALK SECTION**  
(Looking South)

DESIGNED	E.E.J
CHECKED	J.A.Z.
DRAWN	E.E.J.
CHECKED	J.A.Z.

- Notes:
- Existing reinforcement shall be cleaned and incorporated into the new construction. See Sheet 10 of 16 for Bill of Material.
  - If supports for the existing conduit attached to the parapet are removed during construction they must be reinstalled or replaced (if damaged) at no additional cost to the state. Also see the General Notes on Sheet 2 of 33.

**LEGEND**

- Concrete Removal
- Exist. PPC Deck Plank, 2 1/2" thick

**EXPANSION JOINTS  
SB PIERS 3 & 7**  
IL 50 (CICERO AVE) OVER BRC R.R.  
F.A.P. 350, SECTION 50-1 VB-1-BR  
COOK COUNTY

S.N. 016-2512 (S.B.), 016-2513 (N.B.)  
DATE: 10-23-09  
CRAEF  
CHICAGO ILLINOIS

\* Granular or solid flux filled headed studs conforming to Article 1006.32 of the Std. Specs., automatically end welded.

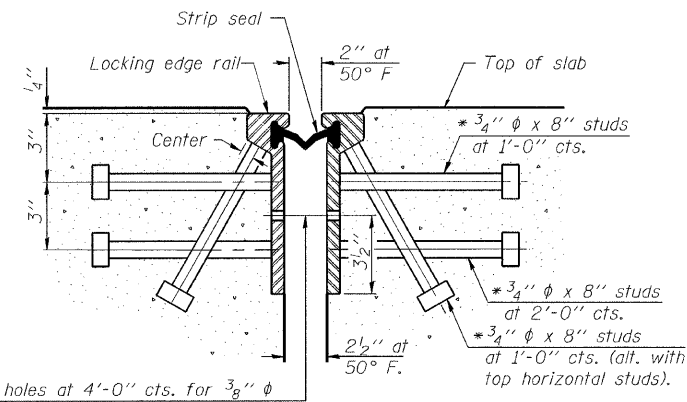

7/16" φ holes at 4'-0" cts. for 3/8" φ bolts. All bolts shall be burned, sawed, or chipped off flush with the plates after forms are removed, typ.

**SECTION THRU ROLLED RAIL JOINT**

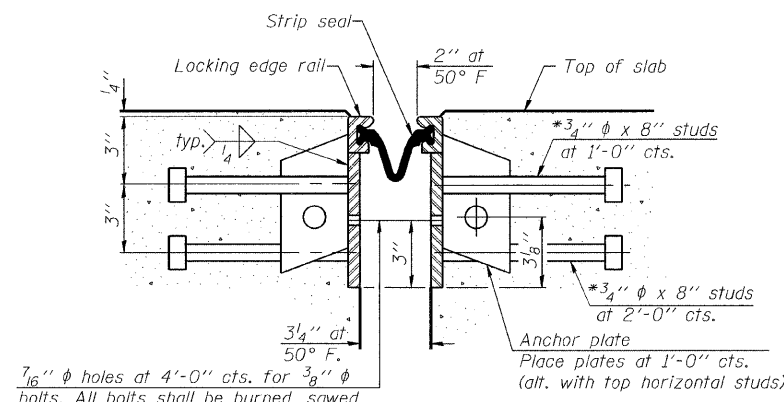

7/16" φ holes at 4'-0" cts. for 3/8" φ bolts. All bolts shall be burned, sawed, or chipped off flush with the plates after forms are removed, typ.

**SECTION THRU WELDED RAIL JOINT**

**Notes:**  
The strip seal shall be made continuous and shall have a minimum thickness of 1/4". The configuration of the strip seal shall match the configuration of the Locking Edge Rails. Open or "webbed" strip seal gland configurations are not permitted. The gland shall be sized for a maximum rated movement of 4 inches.  
The height and thickness of the Locking Edge Rails shown are minimum dimensions. The actual configuration of the Locking Edge Rails and matching strip seal may vary from manufacturer to manufacturer. Flanged edge rails will not be allowed. Locking Edge Rails may be spliced at slope discontinuities and stage construction joints.  
The manufacturer's recommended installation methods shall be followed.  
The joint opening and deck dimensions detailed on the superstructure are based on a rolled rail expansion joint. If the Contractor elects to use the welded rail expansion joint, the opening and deck dimensions shall be modified according to the dimensions detailed on this sheet. Required modifications shall be made at no additional cost to the State.  
All steel components shall be galvanized after fabrication according to Article 520.03 of the Standard Specifications.

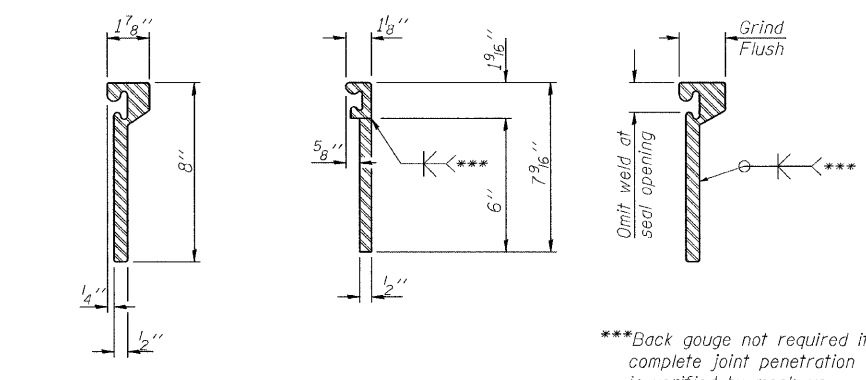

**ROLLED EXTRUDED RAIL**      **WELDED RAIL**

**LOCKING EDGE RAIL SPLICE**

The inside of the locking edge rail groove shall be free of weld residue.

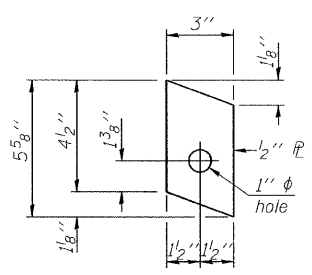

**ANCHOR PLATE**  
(for welded rail)

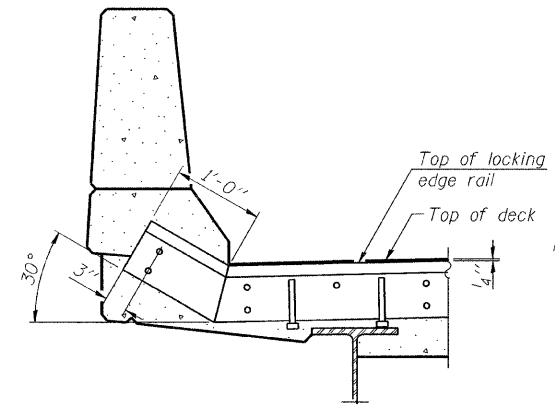

**AT PARAPET**

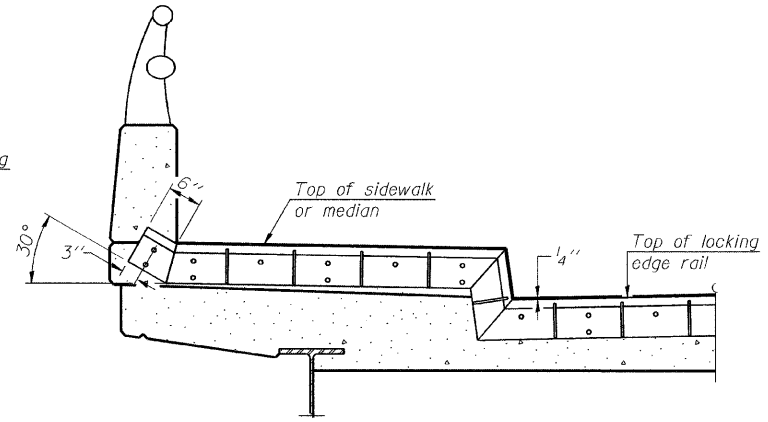

**AT SIDEWALK**

Shorter plates with a single row of studs at 12" cts. may be necessary on medians which are shallower than 9". See manufacturer's recommendation.

**LOCKING EDGE RAILS**

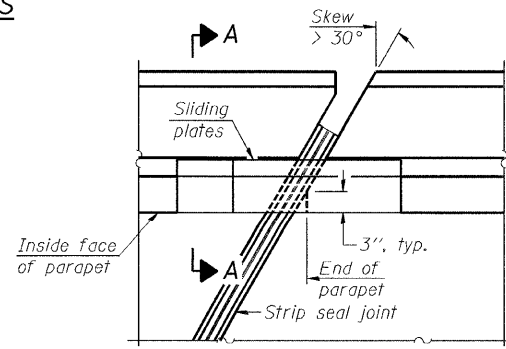

**PLAN**

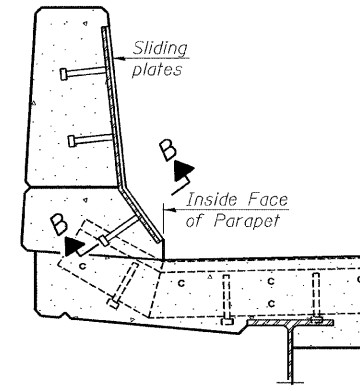

**SECTION A-A**

**POINT BLOCK DETAILS**  
(for skews > 30°)

**TYPICAL END TREATMENTS**

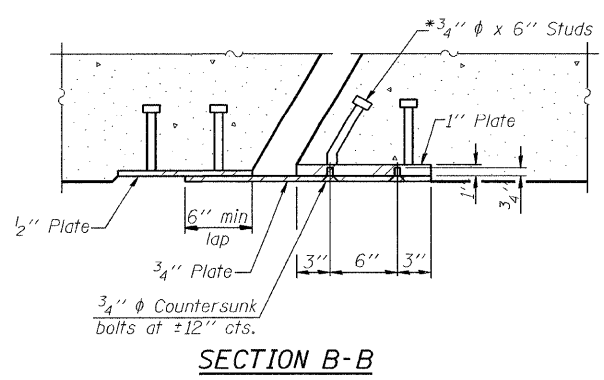

**SECTION B-B**

**BILL OF MATERIAL**

Item	Unit	Total
Preformed Joint Strip Seal	Foot	159

DESIGNED	E.E.J.
CHECKED	J.A.Z.
DRAWN	E.E.J.
CHECKED	J.A.Z.

EJ-SSJ      10-1-08

**PREFORMED JOINT STRIP SEAL**  
IL 50 (CICERO AVE) OVER BRC R.R.  
F.A.P. 350, SECTION 50-1 VB-1-BR  
COOK COUNTY  
  
S.N. 016-2512 (S.B.), 016-2513 (N.B.)  
DATE: 10-23-09  
GRAEF CHICAGO ILLINOIS

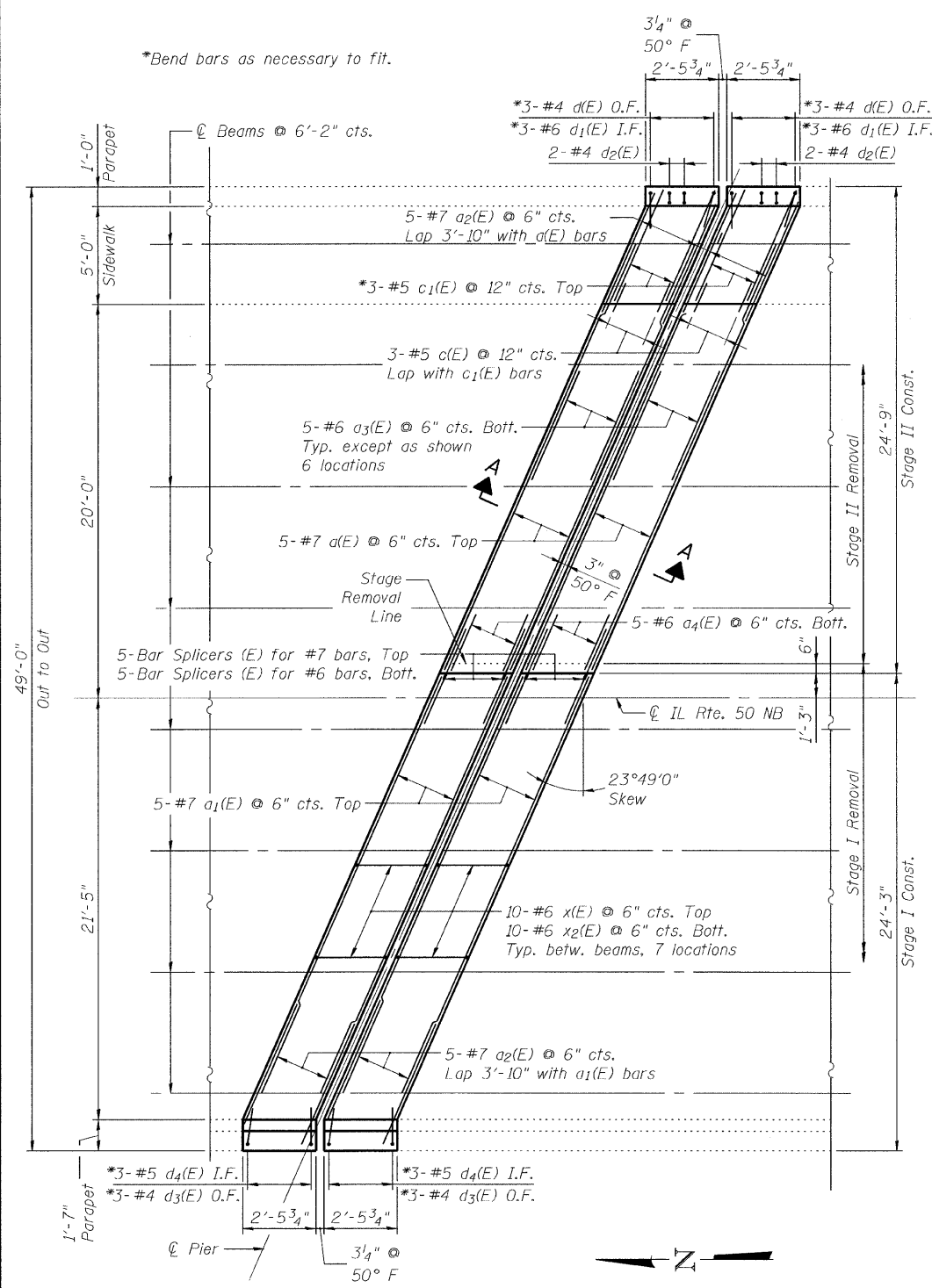

**EXP. JOINT PLAN AT NB PIER 4**

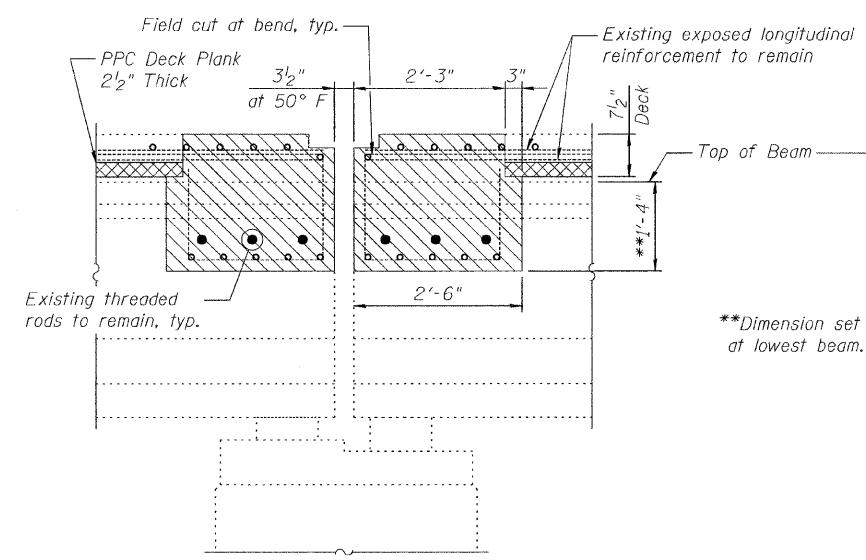

**SECTION A-A  
CONCRETE REMOVAL @ NB PIER 4**  
(Horiz. dimensions at Rt. L's)

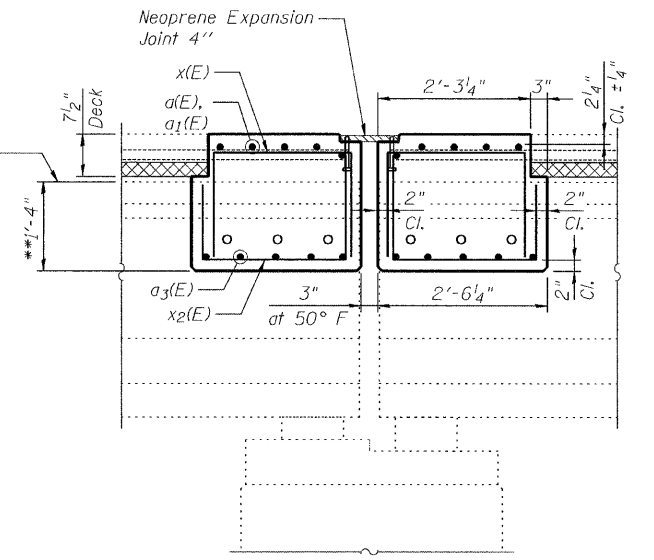

**SECTION A-A  
CONCRETE REPLACEMENT @ NB PIER 4**  
(Horiz. dimensions at Rt. L's)

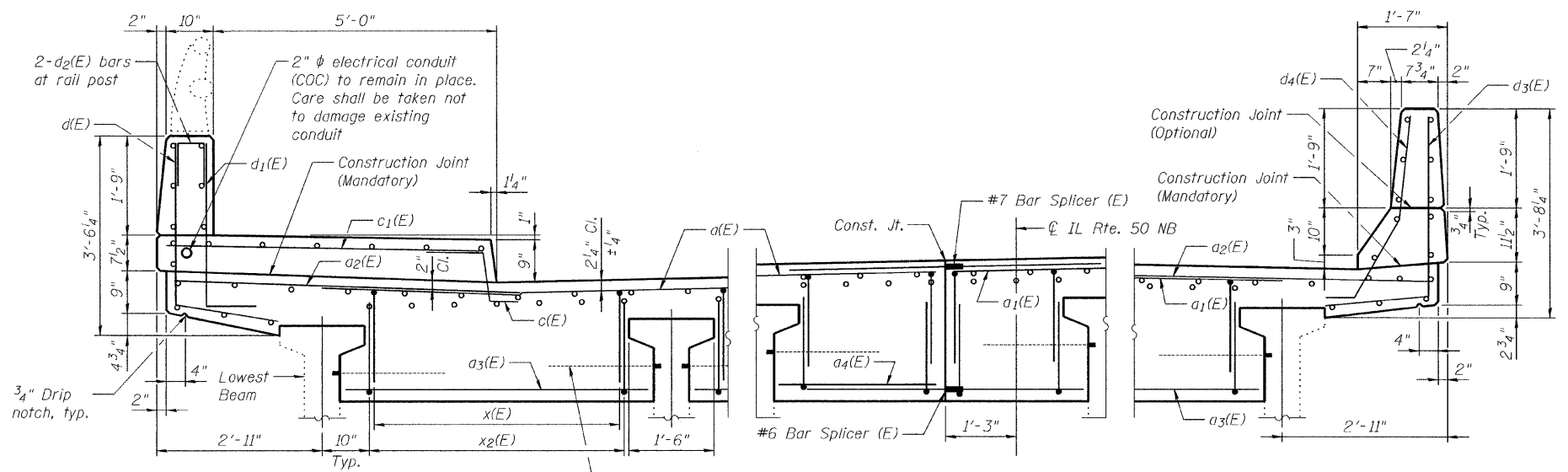

**SIDEWALK SECTION (Looking South)**  
**CENTER SECTION (Looking South)**  
**CURB SECTION (Looking South)**

DESIGNED	E.E.J.
CHECKED	J.A.Z.
DRAWN	E.E.J.
CHECKED	J.A.Z.

- Notes:
- Existing reinforcement shall be cleaned and incorporated into the new construction.
  - See Sheet 10 of 16 for Bill of Material.

- LEGEND**
- Concrete Removal
  - Exist. PPC Deck Plank, 2 1/2" thick

**EXPANSION JOINT, NB PIER 4**  
**IL 50 (CICERO AVE) OVER BRC R.R.**  
**F.A.P. 350, SECTION 50-1 VB-1-BR**  
**COOK COUNTY**

S.N. 016-2512 (S.B.), 016-2513 (N.B.)  
 DATE: 10-23-09  
 GRAEF CHICAGO ILLINOIS

Contract # 60H76

Joint Size	"C" at 50°F	"D" at 50°F
2"	2"	1 1/2" Min.
2 1/2"	2 1/2"	1 3/4" Min.
4"	3"	2 1/2" Min.

### INSTALLATION NOTES

- Install continuous seal in roadway, parapet, curb, and sidewalk.
- Install anchor blocks as indicated.

Note A:  
Maximum spacing of anchor bolts shall be 12" centers.

### SKEW LIMITATIONS

The details of the anchor blocks and the elastomeric membrane in the parapet, as shown, are for up to 50° skews. For skews greater than 50°, the anchor blocks and the elastomeric membrane, installed according to dimension "D", might require modifications to insure a minimum clearance of 1/2" from centerline of anchor studs to edge of parapet opening. The anchor blocks and the elastomeric membrane shall also be installed to the top of the parapet with the anchor studs spaced at ±12" cts.

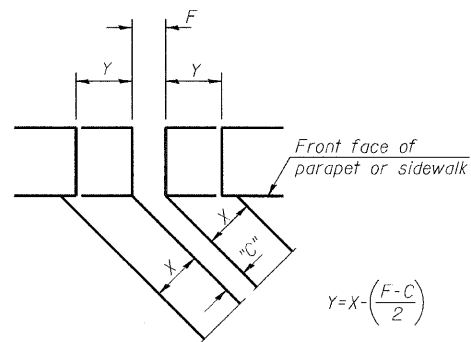

$$Y = X \left( \frac{F-C}{2} \right)$$

For dimension "F" see sheet # 8 of 16

### FORMING BLOCKOUT SKETCH

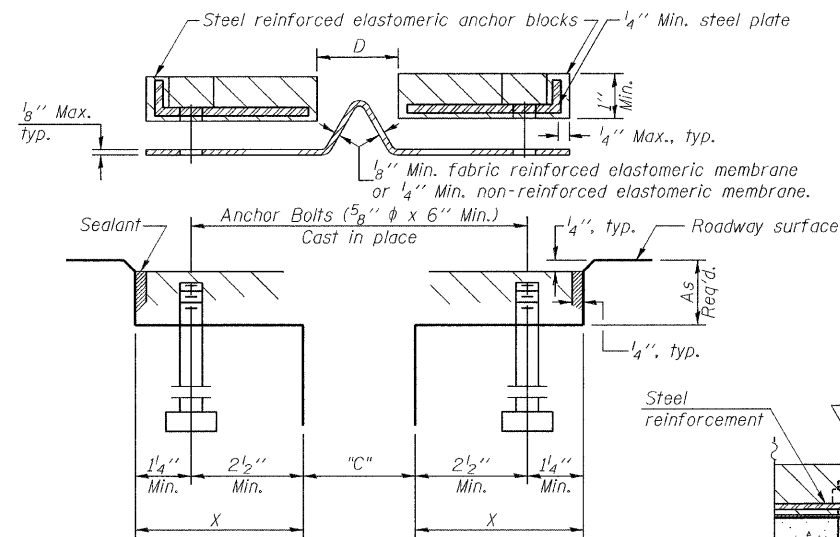

### CROSS SECTION

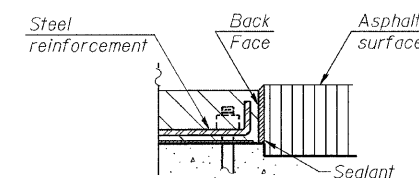

### ANCHOR BLOCK WITH ASPHALT SURFACE

### GENERAL NOTES

Continuous Seal Neoprene Expansion Joint shall consist of molded anchor blocks of elastomer and steel, field assembled over continuous lengths of elastomeric membrane.

The elastomeric membrane shall be premolded with a single or a double upward convolution that will have a "memory" to return to its molded position upon joint closure.

The convolution length shall be such that the extended length will not be greater than the manufactured length when the joint is fully expanded in its design range and will not protrude above the anchor blocks when the joint is fully compressed.

Joint openings shall be adjusted according to Article 520.04 of the Standard Specifications when the deck is poured at an ambient temperature other than 50° F.

The parapet and roadway membrane shall be made continuous by an approved vulcanizing process. Lapping will not be permitted.

After initial setting of the concrete the Temporary Wood Blockout shall be cut.

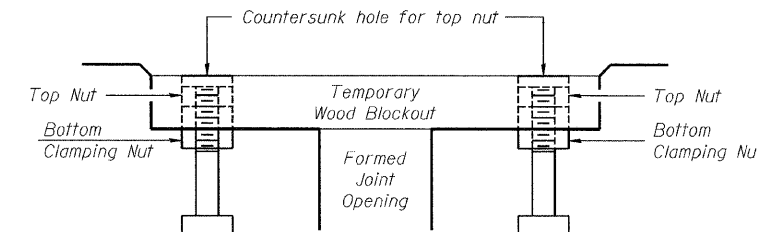

Note:  
Stud needs to be threaded lower to allow for use of clamping nut.

### RECOMMENDED BLOCKOUT DETAIL

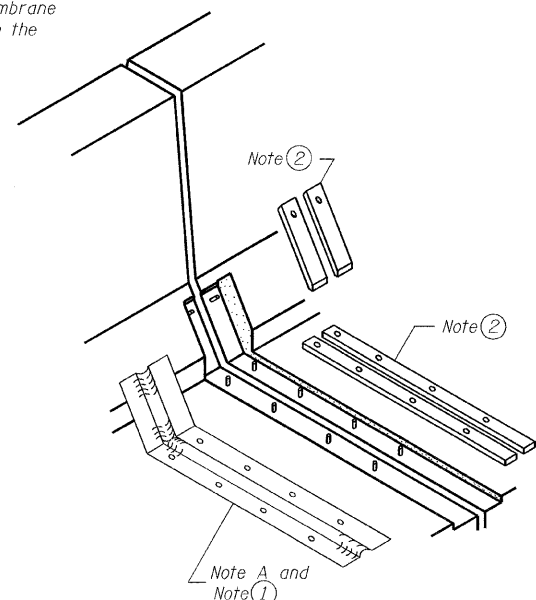

### AT PARAPET

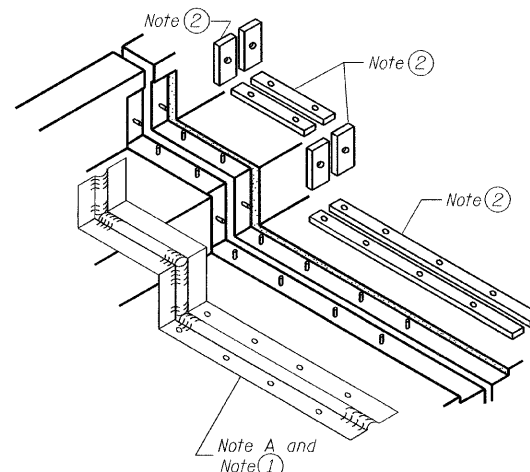

### AT SIDEWALK OR MEDIAN

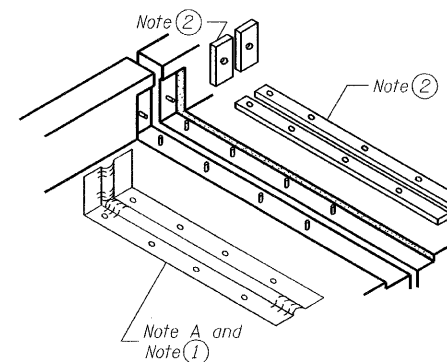

### AT WALL

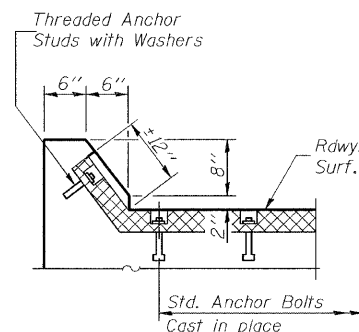

### AT CURB

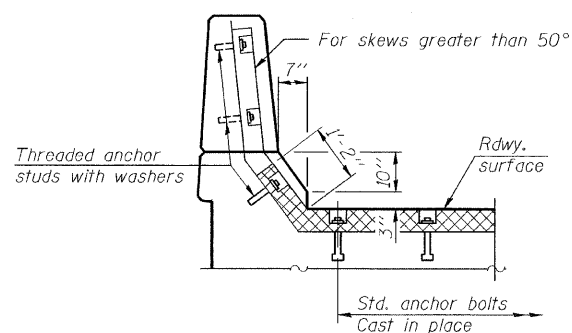

### AT PARAPET

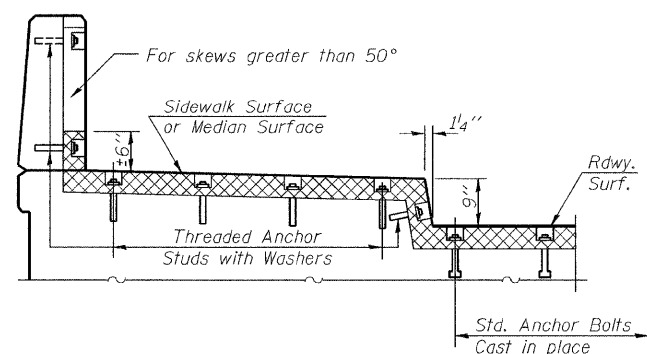

### AT SIDEWALK OR MEDIAN TYPICAL END TREATMENTS

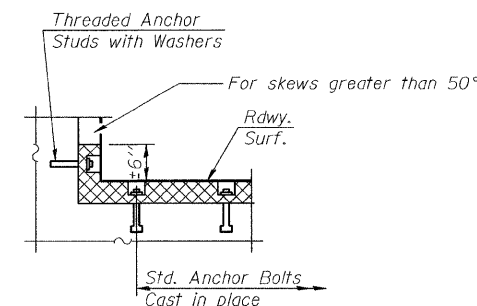

### AT WALL

DESIGNED	E.E.J.
CHECKED	J.A.Z.
DRAWN	E.E.J.
CHECKED	J.A.Z.

EJ-CS

10-22-04

CONTINUOUS SEAL 4" NEOPRENE EXPANSION JOINTS  
IL 50 (CICERO AVE) OVER BRC R.R.  
F.A.P. 350, SECTION 50-1 VB-1-BR  
COOK COUNTY

S.N. 016-2512 (S.B.), 016-2513 (N.B.)  
DATE: 10-23-09  
GRAEF CHICAGO ILLINOIS



F&P ROUTE NO.	SECTION	COUNTY	TOTAL SHEETS	SHEET NO.
350	50-1 VB-1-BR	Cook	33	22
F&P ROAD DIST.		ILLINOIS FED. AID PROJECT		

SHEET NO. 11 OF 16 SHEETS

Contract # 60H76

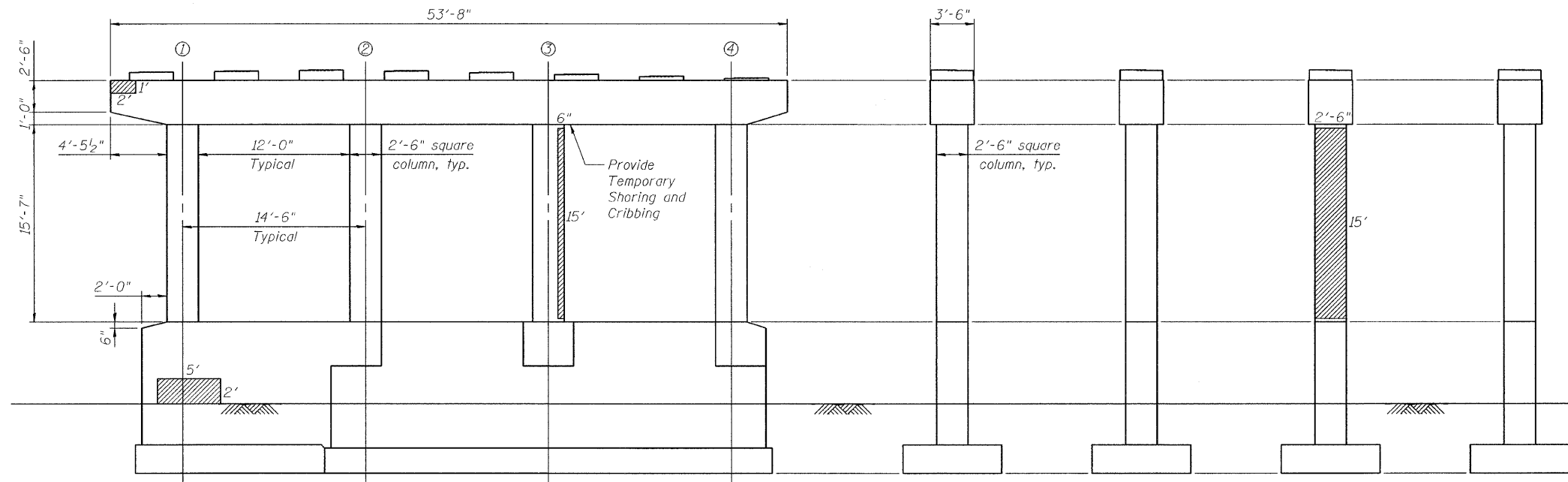

**SB PIER 3 ELEVATION**  
(Looking South)

**COLUMN 1**  
(Looking East)

**COLUMN 2**  
(Looking East)

**COLUMN 3**  
(Looking East)

**COLUMN 4**  
(Looking East)

**SB PIER 3 REACTIONS  
(BEAM LOADS ONLY)**

	Span 3	Span 4
R <sub>DL</sub> (k)	36.8	36.8
R <sub>sDL</sub> (k)	5.0	4.9
R <sub>LL</sub> (k)	33.5	33.6
R <sub>I</sub> (k)	8.6	8.7
R <sub>Total</sub> (k)	83.9	84.0

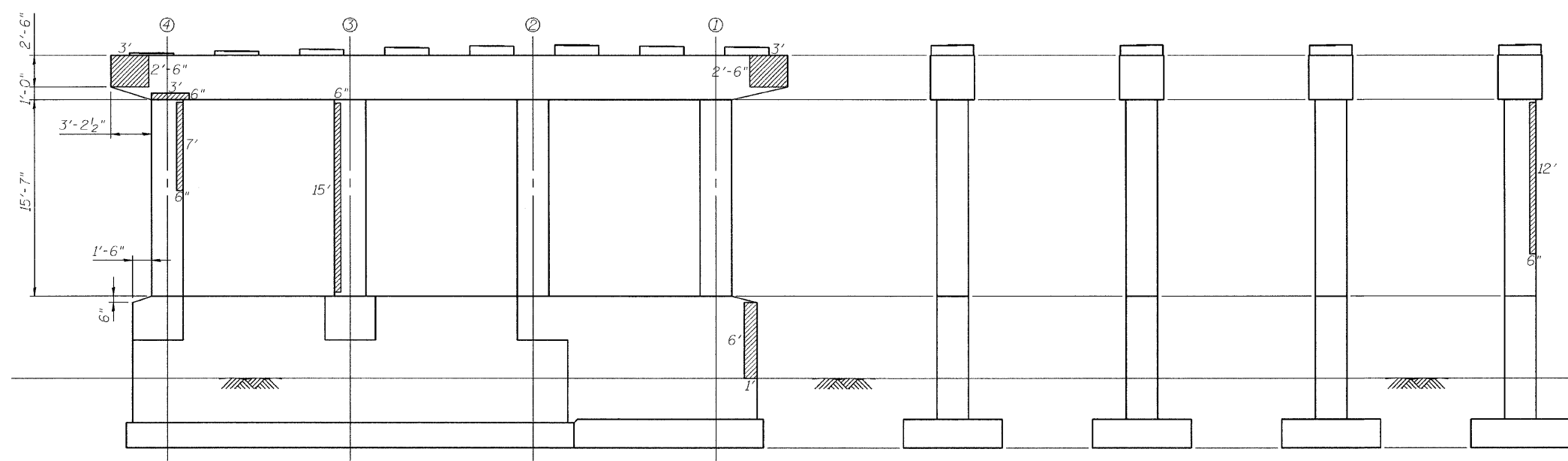

**SB PIER 3 ELEVATION**  
(Looking North)

**COLUMN 4**  
(Looking West)

**COLUMN 3**  
(Looking West)

**COLUMN 2**  
(Looking West)

**COLUMN 1**  
(Looking West)

**BILL OF MATERIAL**

Item	Unit	Quantity
Structural Repair of Concrete (Depth Equal to or Less than 5")	Sq. Ft.	97

**LEGEND**

- Structural Repair of Concrete (Depth equal to or less than 5")
- Column Number

DESIGNED	E.E.J.
CHECKED	J.A.Z.
DRAWN	E.E.J.
CHECKED	J.A.Z.

**SB PIER 3 REPAIRS**  
IL 50 (CICERO AVE) OVER BRC R.R.  
F.A.P. 350, SECTION 50-1 VB-1-BR  
COOK COUNTY

S.N. 016-2512 (S.B.), 016-2513 (N.B.)  
DATE: 10-23-09  
GRAEF  
CHICAGO  
ILLINOIS

F&P ROUTE NO.	SECTION	COUNTY	TOTAL SHEETS	SHEET NO.
350	50-1 VB-1-BR	Cook	33	23
FED. ROAD DIST.		ILLINOIS FED. AID PROJECT		

SHEET NO. 12 OF 16 SHEETS

Contract # 60H76

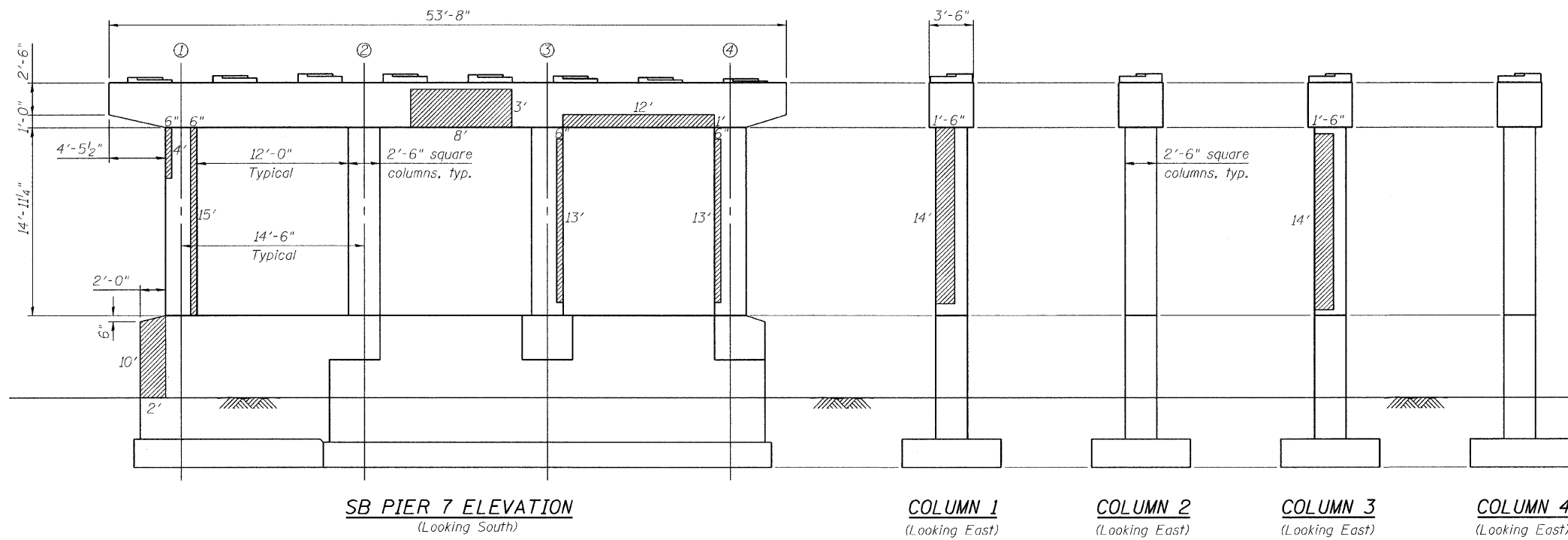

**SB PIER 7 REACTIONS  
(BEAM LOADS ONLY)**

	Span 7	Span 8
$R_{DL}$ (k)	38.9	19.0
$R_{SDL}$ (k)	5.2	2.4
$R_{LL}$ (k)	33.9	28.3
$R_I$ (k)	8.6	8.5
$R_{Total}$ (k)	86.6	58.2

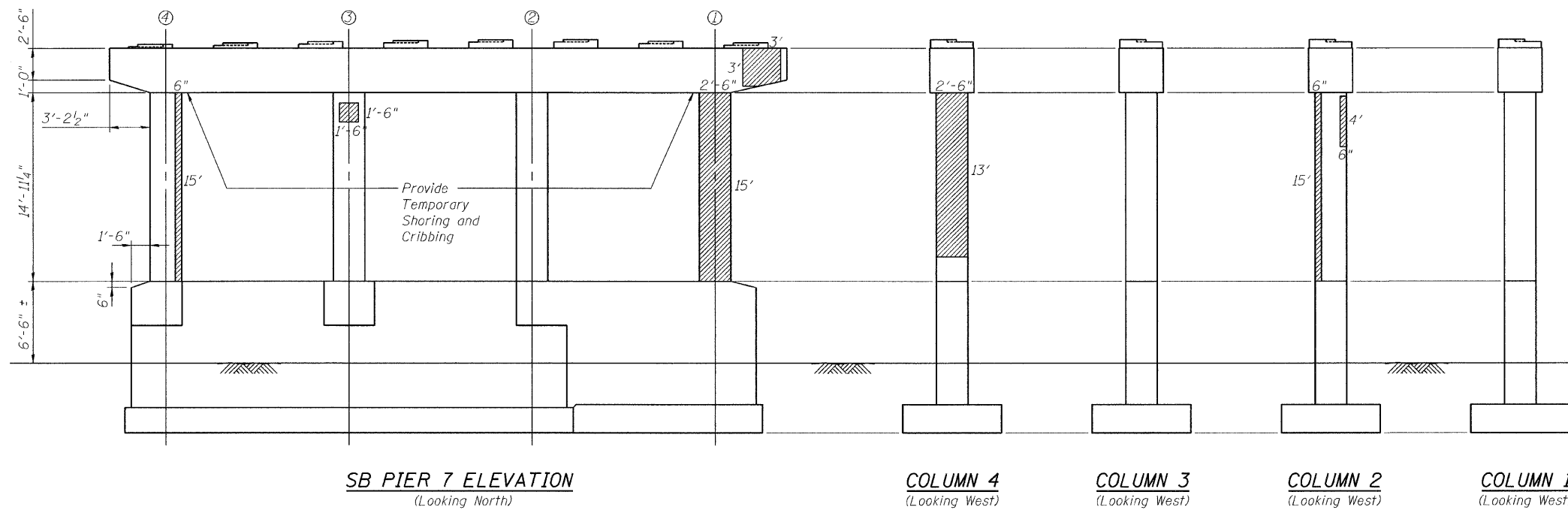

**BILL OF MATERIAL**

Item	Unit	Quantity
Structural Repair of Concrete (Depth Equal to or Less than 5")	Sq. Ft.	219

DESIGNED	E.E.J.
CHECKED	J.A.Z.
DRAWN	E.E.J.
CHECKED	J.A.Z.

**LEGEND**

- Structural Repair of Concrete (Depth equal to or less than 5")
- Column Number

**SB PIER 7 REPAIRS**  
 IL 50 (CICERO AVE) OVER BRC R.R.  
 F.A.P. 350, SECTION 50-1 VB-1-BR  
 COOK COUNTY  
 S.N. 016-2512 (S.B.), 016-2513 (N.B.)  
 DATE: 10-23-09  
 GRAEF  
 CHICAGO ILLINOIS

Contract # 60H76

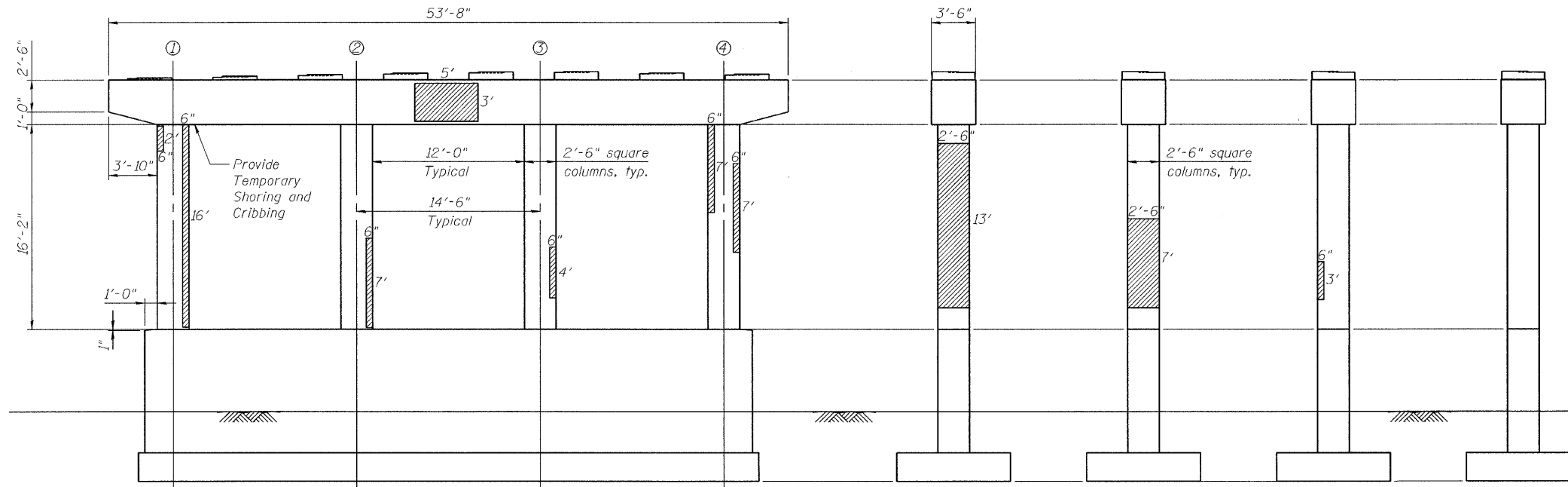

**NB PIER 4 ELEVATION**  
(Looking South)

**COLUMN 1**  
(Looking East)

**COLUMN 2**  
(Looking East)

**COLUMN 3**  
(Looking East)

**COLUMN 4**  
(Looking East)

**NB PIER 4 REACTIONS  
(BEAM LOADS ONLY)**

	Span 4	Span 5
$R_{DL}$ (k)	36.4	39.5
$R_{sDL}$ (k)	4.3	4.4
$R_{LL}$ (k)	32.9	33.6
$R_T$ (k)	8.8	8.8
$R_{Total}$ (k)	82.4	86.3

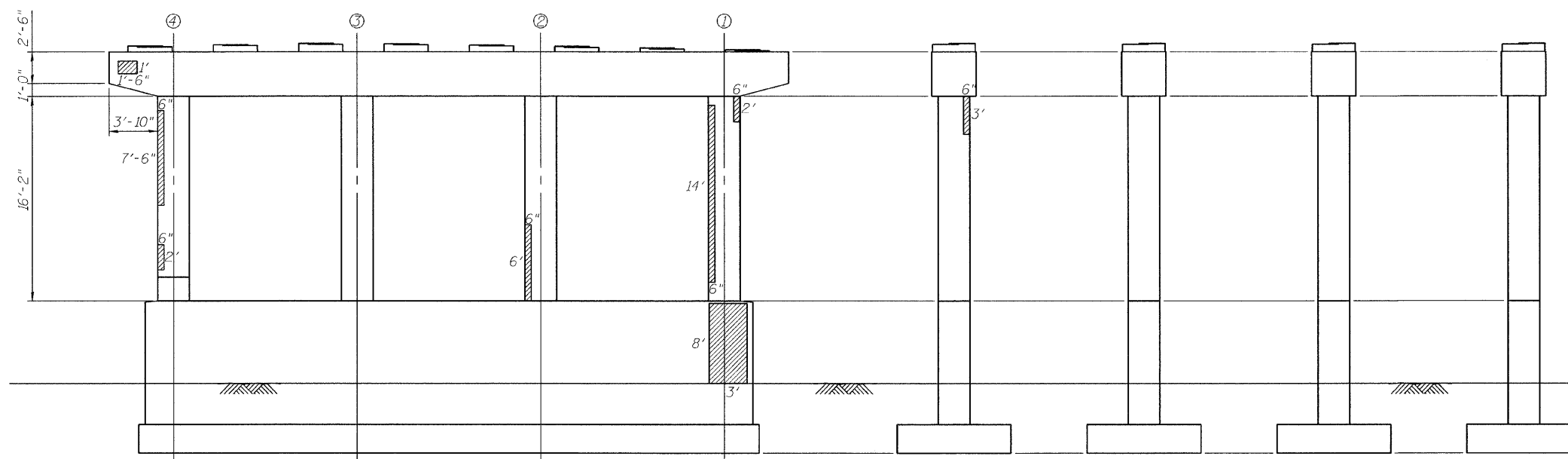

**NB PIER 4 ELEVATION**  
(Looking North)

**COLUMN 4**  
(Looking West)

**COLUMN 3**  
(Looking West)

**COLUMN 2**  
(Looking West)

**COLUMN 1**  
(Looking West)

**BILL OF MATERIAL**

Item	Unit	Quantity
Structural Repair of Concrete (Depth Equal to or Less than 5")	Sq. Ft.	131

**LEGEND**

- Structural Repair of Concrete (Depth equal to or less than 5")
- Column Number

DESIGNED	E.E.J.
CHECKED	J.A.Z.
DRAWN	E.E.J.
CHECKED	J.A.Z.

**NB PIER 4 REPAIRS**  
IL 50 (CICERO AVE) OVER BRC R.R.  
F.A.P. 350, SECTION 50-1 VB-1-BR  
COOK COUNTY  
S.N. 016-2512 (S.B.), 016-2513 (N.B.)  
DATE: 10-23-09  
GRAEF  
CHICAGO  
ILLINOIS



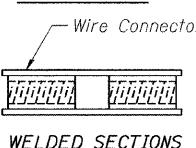
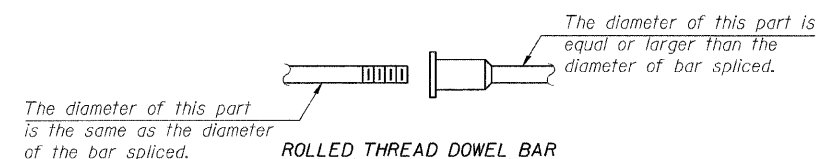

**BAR SPLICER ASSEMBLY ALTERNATIVES**

\*\*Heavy Hex Nuts conforming to ASTM A 563, Grade C, D or DH may be used.

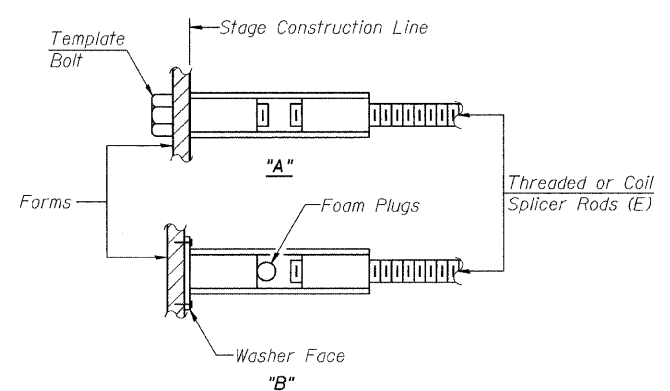

**INSTALLATION AND SETTING METHODS**

"A" : Set bar splicer assembly by means of a template bolt.  
 "B" : Set bar splicer assembly by nailing to wood forms or cementing to steel forms.  
 (E) : Indicates epoxy coating.

**NOTES**

Bar splicer assemblies shall be of an approved type and shall develop in tension at least 125 percent of the yield strength of the lapped reinforcement bars.  
 Splicer rods shall be of minimum 60 ksi yield strength, threaded or coiled full length.  
 All reinforcement bars shall be lapped and tied to the splicer rods or dowel bars.  
 Bar splicer assemblies shall be epoxy coated according to the requirements for reinforcement bars.  
 Other systems of similar design may be submitted to the Engineer for approval. Approval shall be based on certified test results from an approved testing laboratory that the proposed bar splicer assembly satisfies the following requirements:

- ① Minimum Capacity (Tension in kips) =  $1.25 \times f_y \times A_t$
  - ② Minimum \*Pull-out Strength (Tension in kips) =  $0.66 \times f_y \times A_t$
- Where  $f_y$  = Yield strength of lapped reinforcement bars in ksi.  
 $A_t$  = Tensile stress area of lapped reinforcement bars.  
 \* = 28 day concrete

Bar Size to be Spliced	Splicer Rod or Dowel Bar Length	Strength Requirements	
		Min. Capacity kips - tension	Min. Pull-Out Strength kips - tension
#4	1'-8"	14.7	7.9
#5	2'-2"	23.0	12.3
#6	2'-7"	33.1	17.4
#7	3'-5"	45.1	23.8
#8	4'-6"	58.9	31.3
#9	5'-9"	75.0	39.6
#10	7'-3"	95.0	50.3
#11	9'-0"	117.4	61.8

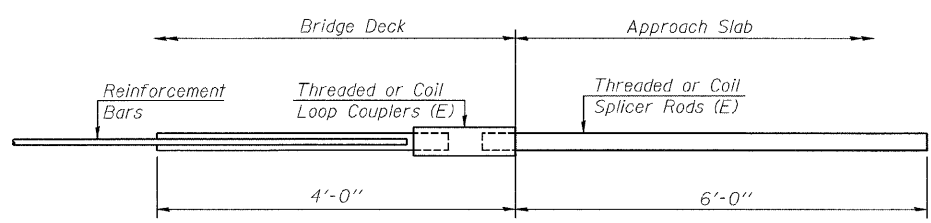

**FOR INTEGRAL OR SEMI-INTEGRAL ABUTMENTS**

Bar Splicer for #5 bar
Min. Capacity = 23.0 kips - tension
Min. Pull-out Strength = 12.3 kips - tension
No. Required =

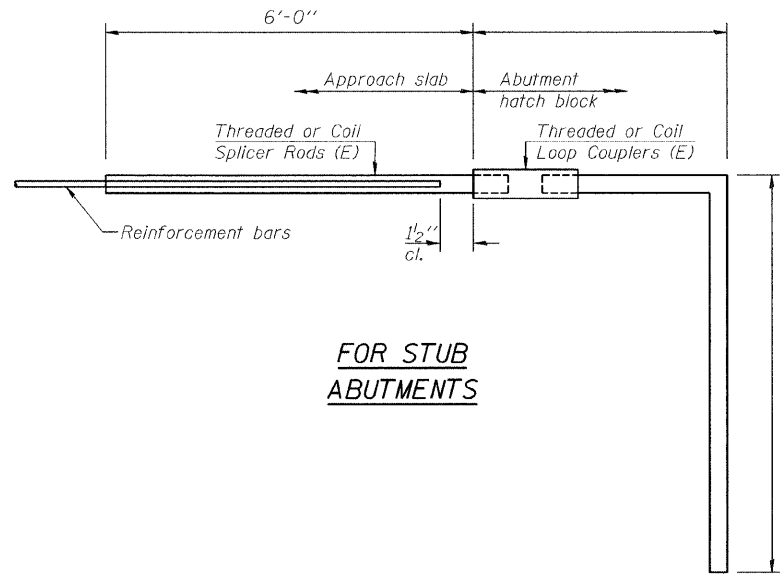

**FOR STUB ABUTMENTS**

Bar Splicer for #5 bar
Min. Capacity = 23.0 kips - tension
Min. Pull-out Strength = 12.3 kips - tension
No. Required =

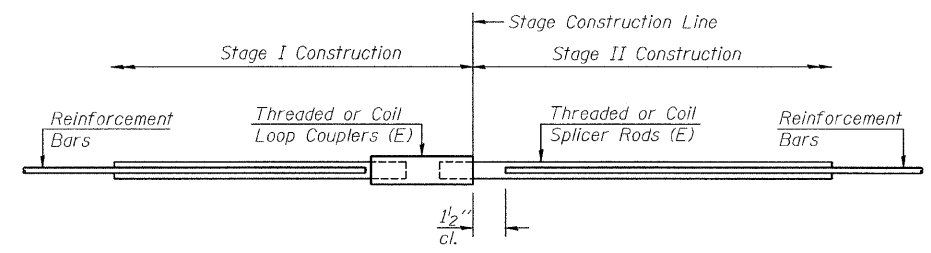

**STANDARD**

Bar Size	No. Assemblies Required	Location
#6	10	SB PIER 3
#7	10	SB PIER 3
#6	10	SB PIER 7
#7	10	SB PIER 7
#6	10	NB PIER 4
#7	10	NB PIER 4
#6	9	NB S. ABUT.
#7	5	NB S. ABUT.

**BAR SPLICER ASSEMBLY DETAILS**  
 IL 50 (CICERO AVE) OVER BRC R.R.  
 F.A.P. 350, SECTION 50-1 VB-1-BR  
 COOK COUNTY

S.N. 016-2512 (S.B.), 016-2513 (N.B.)  
 DATE: 10-23-09  
 GRAEF CHICAGO ILLINOIS

DESIGNED E.E.J.  
 CHECKED J.A.Z.  
 DRAWN E.E.J.  
 CHECKED J.A.Z.

STATE OF ILLINOIS  
DEPARTMENT OF TRANSPORTATION

MAP ROUTE NO.	SECTION	COUNTY	TOTAL SHEETS	SHEET NO.
350	50-1 VB-1-BR	Cook	33	26
FED. ROAD DIST.		ILLINOIS	FED. AID PROJECT-	

Contract # 60H76

SHEET NO. 15 OF  
16 SHEETS

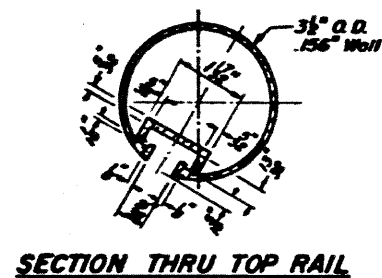

SECTION THRU TOP RAIL

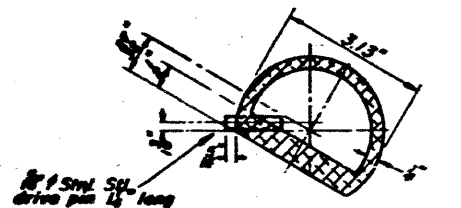

SECTION THRU SPLICE  
TOP RAIL

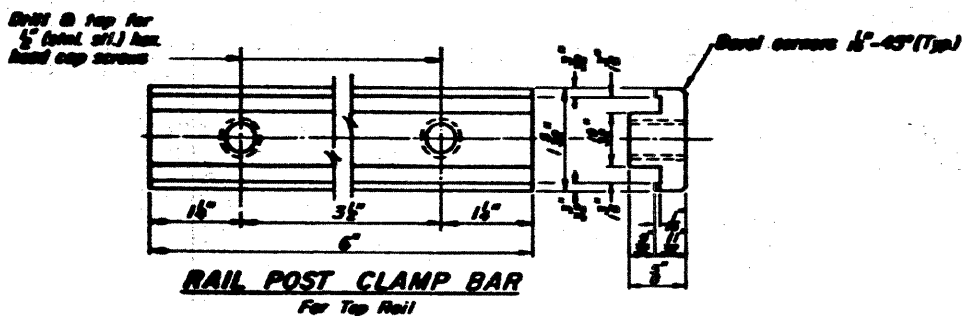

RAIL POST CLAMP BAR  
For Top Rail

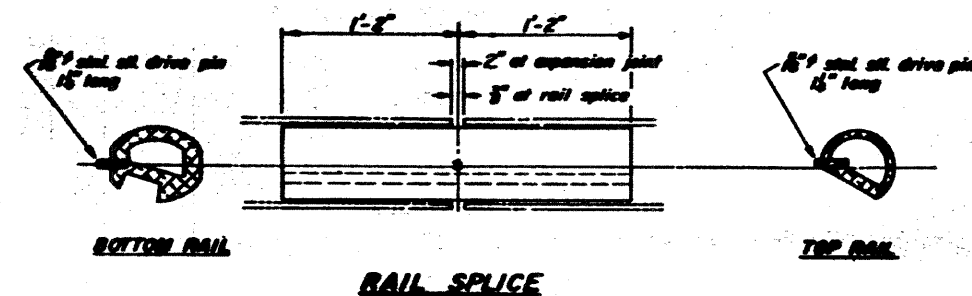

RAIL SPLICE

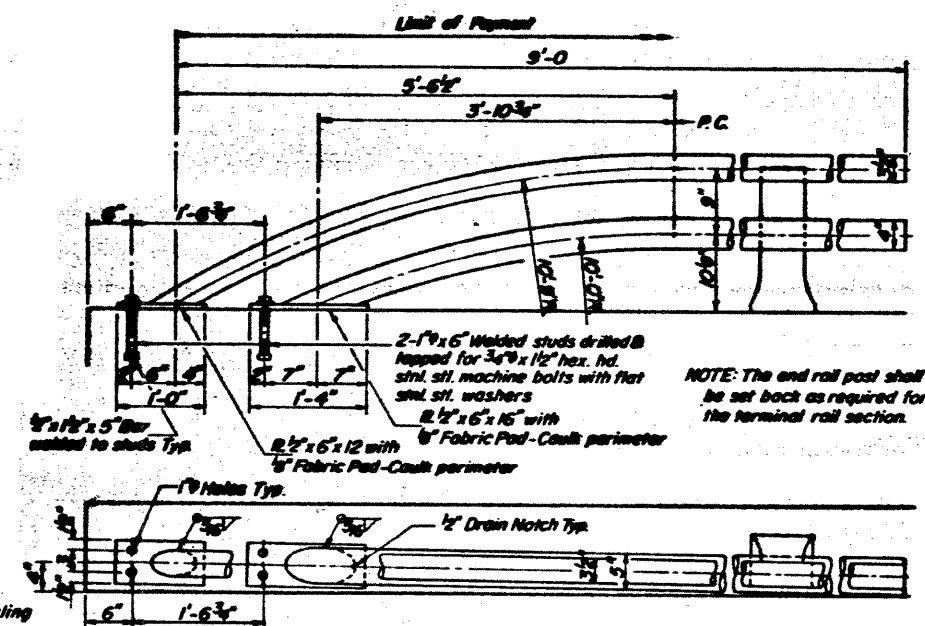

RAIL TERMINAL SECTION

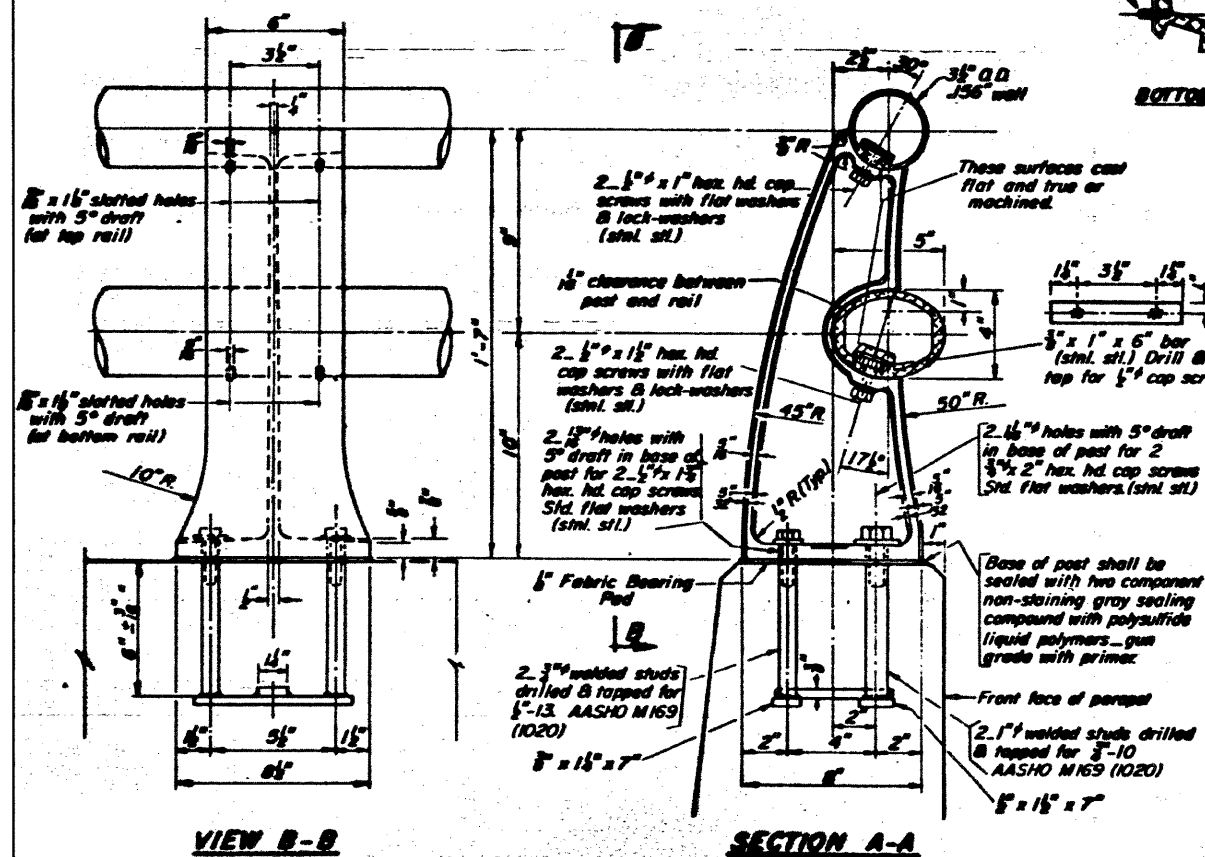

RAIL POST DETAILS

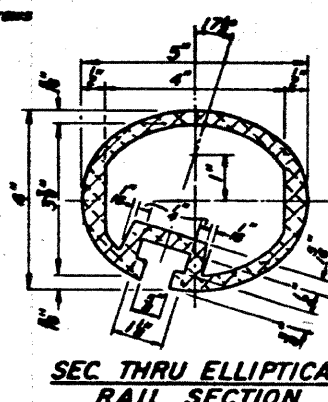

SEC. THRU ELLIPTICAL  
RAIL SECTION

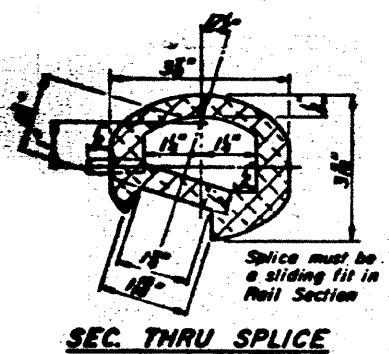

SEC. THRU SPLICE

Two component non-staining gray sealing compound with polysulfide liquid polymers - gun grade with primer

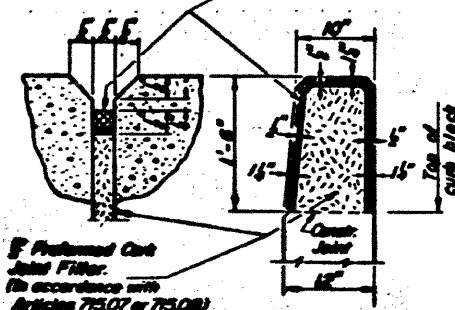

PARAPET JOINT DETAIL

NOTE: The end rail post shall be set back as required for the terminal rail section.

FOR INFORMATION  
ONLY

DESIGNED	E.E.J.
CHECKED	J.A.Z.
DRAWN	E.E.J.
CHECKED	J.A.Z.

RAILING  
IL 50 (CICERO AVE) OVER BRC R.R.  
F.A.P. 350, SECTION 50-1 VB-1-BR  
COOK COUNTY  
S.N. 016-2512 (S.B.), 016-2513 (N.B.)  
DATE: 10-23-09  
GRAEF  
CHICAGO ILLINOIS

PAP. ROUTE NO.	SECTION	COUNTY	TOTAL SHEETS	SHEET NO.
350	50-1 VB-1-BR	Cook	33	27
FED. ROAD DIST.		ILLINOIS		
		FED. AID PROJECT-		

SHEET NO. 16 OF 16 SHEETS

Contract # 60H76

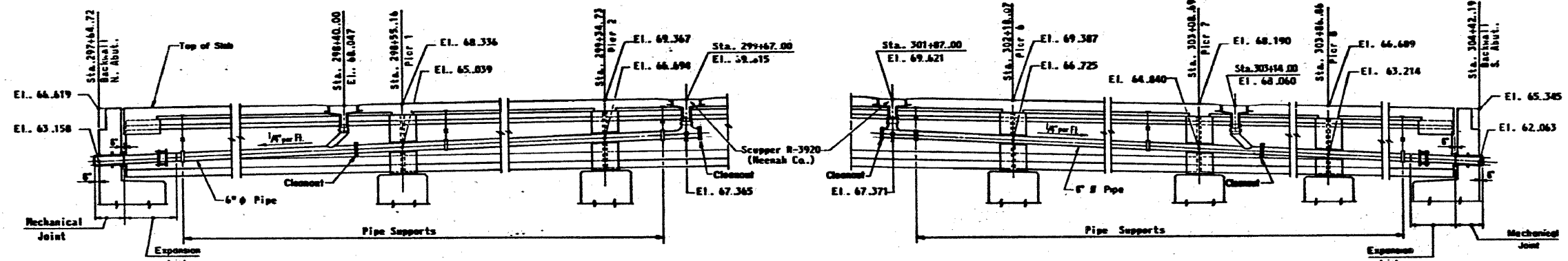

NOTE Stations and Elevations shown are along face of Curb of Gutter Line (Typical)

**DECK DRAINS - NORTHBOUND**

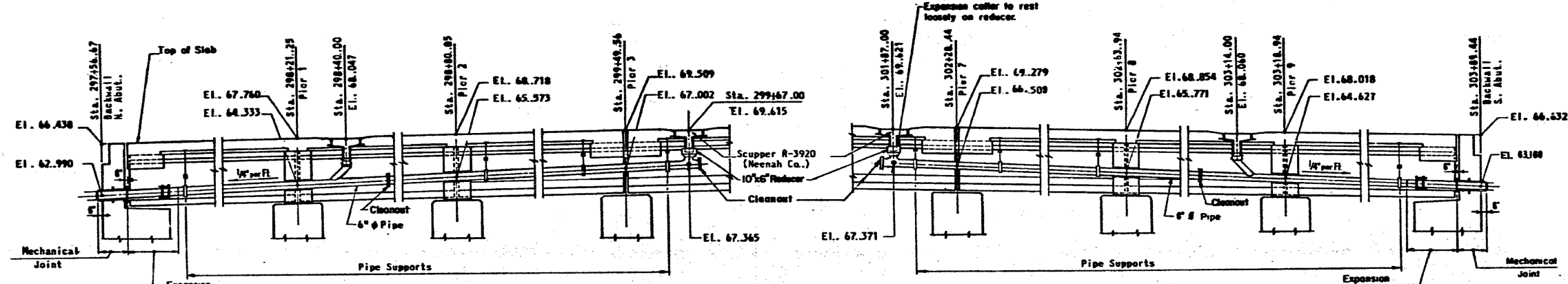

**DECK DRAINS - SOUTHBOUND**

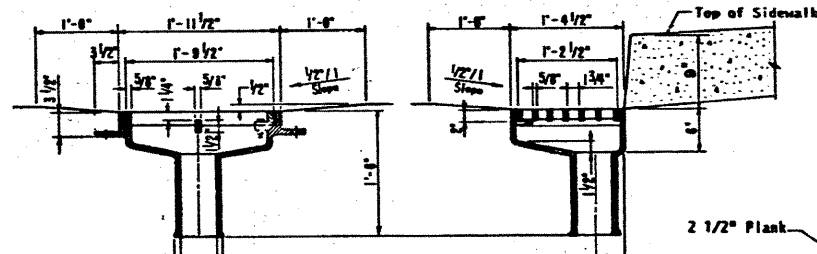

**SCUPPER DETAILS**  
NEENAH R-3920 OR EQUAL

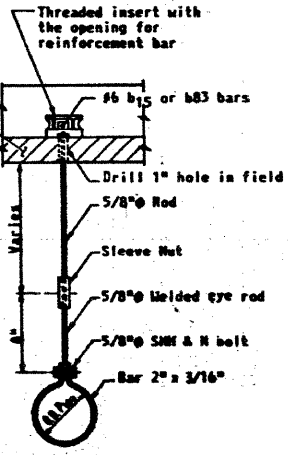

**PIPE ROLL SUPPORT**  
(S.S. - Spans 4 & 7 only)

**PIPE SUPPORT**  
(N.B. & S.B. - All Spans Except Spans 4 & 7 S.B.)

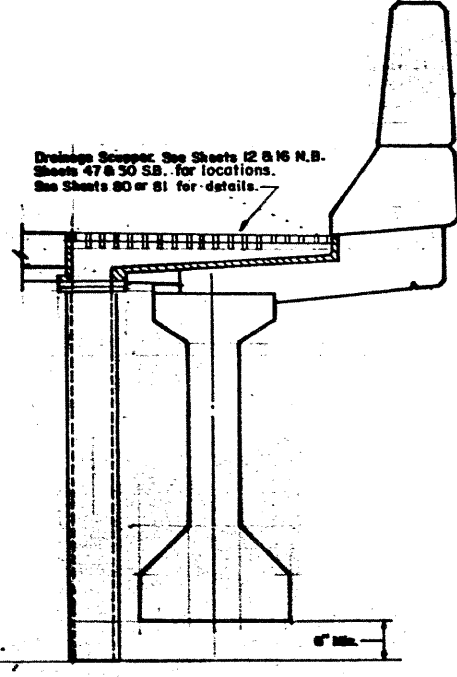

**SECTION AT DRAINAGE SCUPPER**

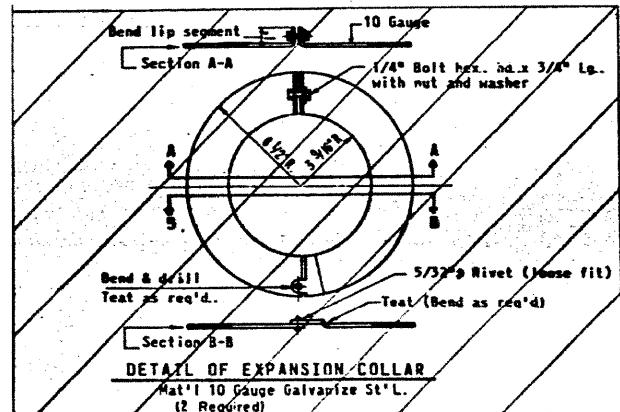

**DETAIL OF EXPANSION COLLAR**  
Mat' 10 Gauge Galvalize St'L.  
(2 Required)

FOR INFORMATION ONLY

DESIGNED	E.E.J.
CHECKED	J.A.Z.
DRAWN	E.E.J.
CHECKED	J.A.Z.

**DRAINAGE SYSTEM**  
IL 50 (CICERO AVE) OVER BRC R.R.  
F.A.P. 350, SECTION 50-1 VB-1-BR  
COOK COUNTY

S.N. 016-2512 (S.B.), 016-2513 (N.B.)  
DATE: 10-23-09

GRAF CHICAGO ILLINOIS

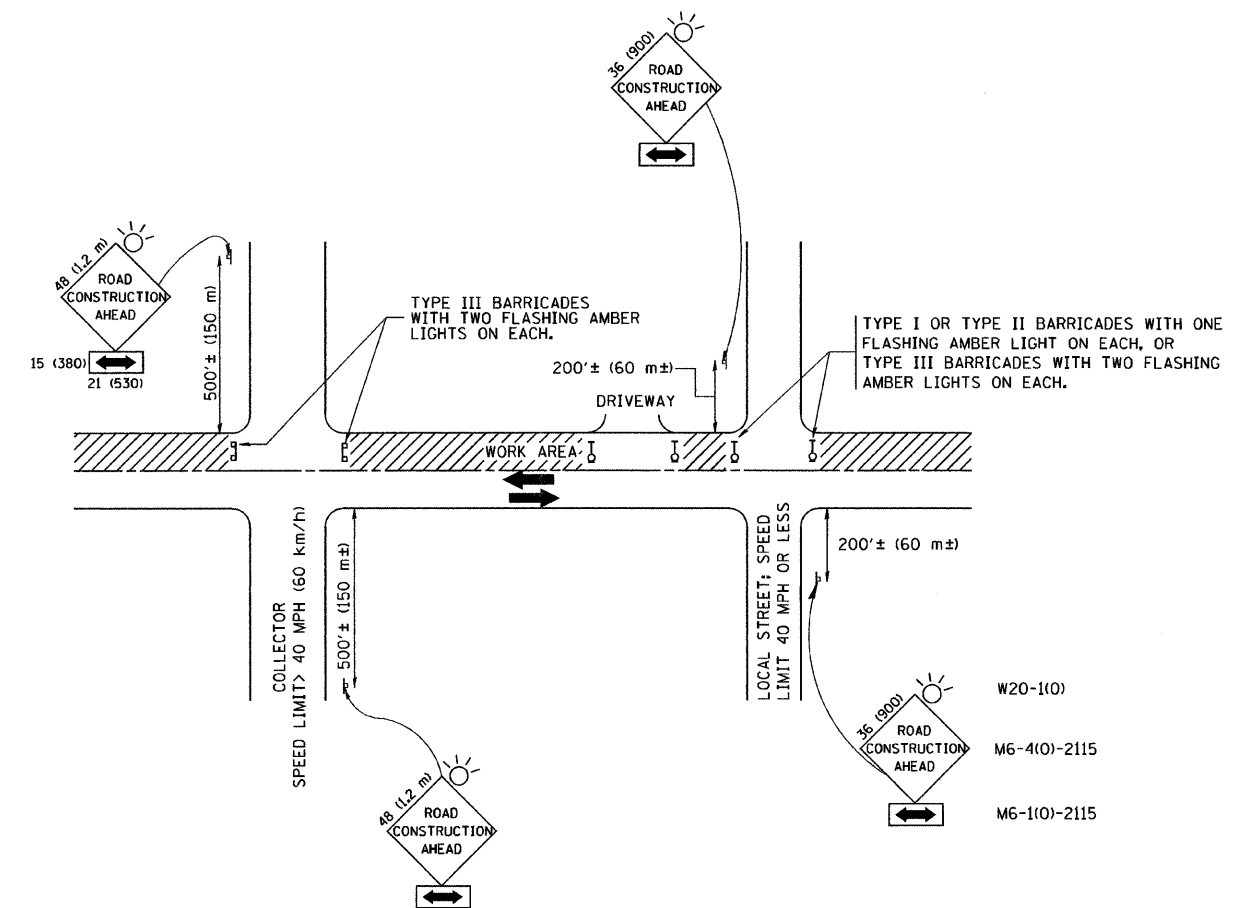

TRAFFIC CONTROL AND PROTECTION FOR SIDE ROADS, INTERSECTIONS, AND DRIVEWAYS

NOTES:

- A. FOR NO LANE RESTRICTION ON THE SIDE ROAD OR DRIVEWAYS
  1. SIDE ROAD WITH A SPEED LIMIT OF 40 MPH (60 km/h) OR LESS AS SHOWN ON THE DRAWING AND AS DIRECTED BY THE ENGINEER:
    - a) ONE ROAD CONSTRUCTION AHEAD SIGN 36 x 36 (900x900) WITH A FLASHER AND FLAG MOUNTED ON IT APPROXIMATELY 200' (60 m) IN ADVANCE OF THE MAIN ROUTE.
    - b) THE CLOSED PORTION OF THE MAIN ROUTE SHALL BE PROTECTED BY BLOCKING WITH TYPE I, TYPE II OR TYPE III BARRICADES, 1/3 OF THE CROSS SECTION OF THE CLOSED PORTION.
  2. SIDE ROAD WITH A SPEED LIMIT GREATER THAN 40 MPH (60 km/h) AS SHOWN ON THE DRAWING AND AS DIRECTED BY THE ENGINEER:
    - a) ONE ROAD CONSTRUCTION AHEAD SIGN 48 x 48 (1.2 m x 1.2 m) WITH A FLASHER MOUNTED ON IT APPROXIMATELY 500' (150 m) IN ADVANCE OF THE MAIN ROUTE.
    - b) THE CLOSED PORTION OF THE MAIN ROUTE SHALL BE PROTECTED BY BLOCKING WITH TYPE III BARRICADES, 1/2 OF THE CROSS SECTION OF THE CLOSED PORTION.
- B. FOR A LANE CLOSURE ON A SIDE ROAD OR DRIVEWAY:
 

USE APPLICABLE PORTIONS OF THE TYPICAL APPLICATION OF TRAFFIC CONTROL DEVICES (STD. 701501, STD. 701606 OR THE APPROPRIATE STANDARD). THE SPACING OF SIGNS AND BARRICADES SHALL BE ADJUSTED FOR FIELD CONDITIONS AS DIRECTED BY THE ENGINEER. THE DIRECTIONAL ARROW SHALL BE COVERED OR REMOVED WHEN NO LONGER CONSISTENT WITH THE SIDE ROAD LANE CLOSURE.
- C. ADVANCE WARNING SIGNS ARE TO BE OMITTED ON DRIVEWAY UNLESS OTHERWISE NOTED.
- D. THE TRAFFIC CONTROL AND PROTECTION FOR SIDE ROADS, INTERSECTIONS, AND DRIVEWAYS SHALL BE INCIDENTAL TO THE COST OF SPECIFIED TRAFFIC CONTROL STANDARDS OR ITEMS.

All dimensions are in millimeters (inches) unless otherwise shown.

FILE NAME = W:\diststd\22x34\tcl8.dgn	USER NAME = gaglionbt	DESIGNED - LHA	REVISED - J. OBERLE 10-18-95
		DRAWN -	REVISED - A. HOUSEH 03-06-96
		CHECKED -	REVISED - A. HOUSEH 10-15-96
		DATE - 06-89	REVISED - T. RAMMACHER 01-06-00

STATE OF ILLINOIS  
DEPARTMENT OF TRANSPORTATION

TRAFFIC CONTROL AND PROTECTION FOR SIDE ROADS, INTERSECTIONS, AND DRIVEWAYS			
SCALE: NONE	SHEET NO. 1 OF 1 SHEETS	STA.	TO STA.

F.A.P. RTE.	SECTION	COUNTY	TOTAL SHEETS	SHEET NO.
350	50-1 VB-1-BR	COOK	33	28
TC-10			CONTRACT NO.	
FED. ROAD DIST. NO. 1 ILLINOIS FED. AID PROJECT				

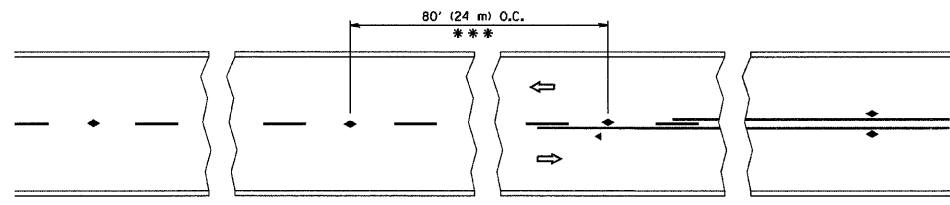

\*\*\* REDUCE TO 40' (12 m) O.C. ON CURVES WITH POSTED OR ADVISORY SPEED 45 M.P.H. (70 km/h) OR LESS.

TWO-LANE/TWO-WAY

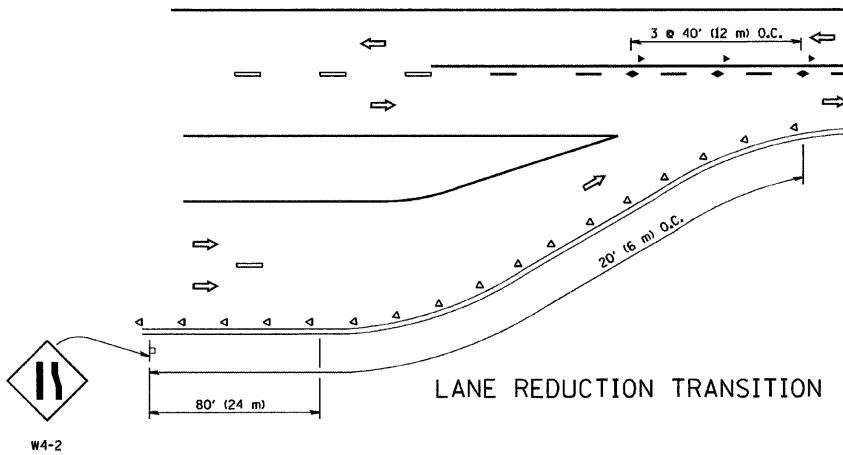

LANE REDUCTION TRANSITION

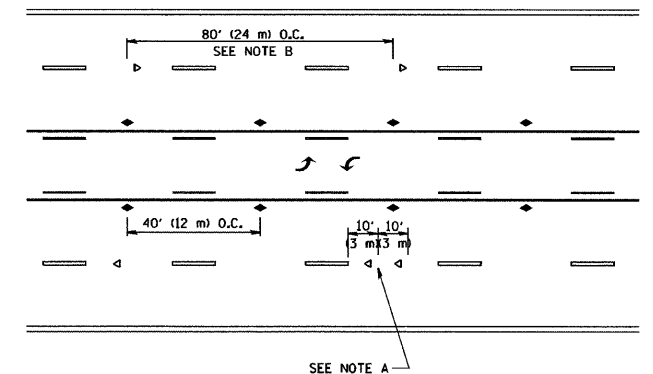

TWO-WAY LEFT TURN

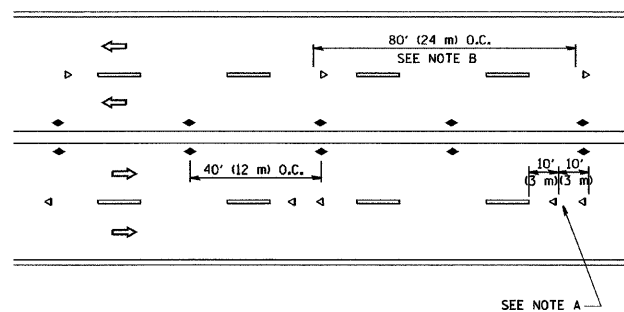

MULTI-LANE/UNDIVIDED

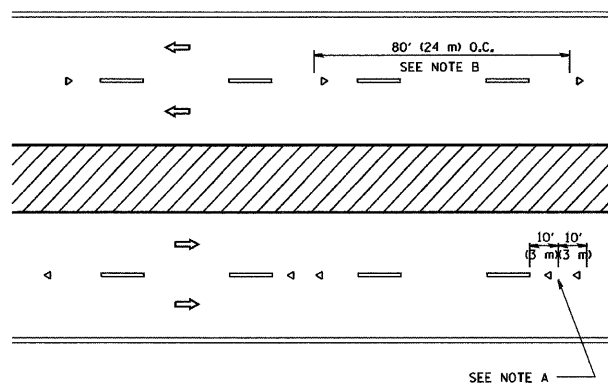

MULTI-LANE/DIVIDED

GENERAL NOTES

1. MARKERS USED WITH DASHED LINES SHALL BE CENTERED IN THE GAP BETWEEN SEGMENTS.
2. MARKERS USED ADJACENT TO SOLID LINES SHALL BE OFFSET 2 TO 3 (50 TO 75) TOWARD TRAFFIC AS SHOWN.
3. MARKERS THROUGH TANGENTS LESS THAN 500' (150 m) IN LENGTH BETWEEN CURVES SHALL BE INSTALLED AT THE LESSER OF THE TWO CURVE SPACINGS.

SYMBOLS

- YELLOW STRIPE
- WHITE STRIPE
- ◀ ONE-WAY AMBER MARKER
- ◁ ONE-WAY CRYSTAL MARKER (W/O)
- ◆ TWO-WAY AMBER MARKER

LANE MARKER NOTES

- B. REDUCE TO 40' (12 m) O.C. ON CURVES WHERE ADVISORY SPEEDS ARE 10 M.P.H. (20 km/h) LOWER THAN POSTED SPEEDS.
- A. USE DOUBLE LANE LINE MARKERS SPACED AS SHOWN.

DESIGN NOTES

1. DOUBLE LANE LINE MARKERS SHALL BE USED UNLESS SPECIFIED OTHERWISE.
2. EXCEPT AS SHOWN ON THE LANE REDUCTION TRANSITION AND FREEWAY EXIT RAMP DETAIL, MARKERS ARE NOT TO BE SPECIFIED ON RIGHT EDGE LINES.
3. THE EXACT MARKER LIMITS, SPACING, AND COLOR SHOULD BE INCLUDED IN THE PLANS.
4. MARKERS SHOULD NOT BE USED ALONGSIDE CURBS EXCEPT FOR EXTREMELY SHORT SECTIONS OF CURBS WHERE NOT MORE THAN TWO MARKERS WOULD BE INVOLVED.

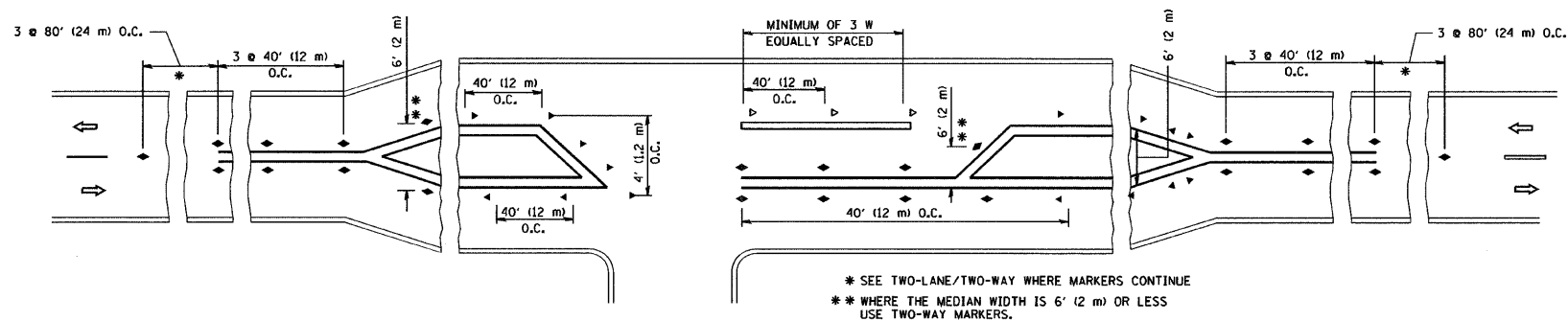

LEFT TURN

All dimensions are in inches (millimeters) unless otherwise shown.

FILE NAME = W:\dststd\22x34\td1.dgn	USER NAME = gaglionobt	DESIGNED -	REVISED - T. RAMMACHER 09-19-94	<b>STATE OF ILLINOIS DEPARTMENT OF TRANSPORTATION</b>	<b>TYPICAL APPLICATIONS</b>		F.A.P. RTE.	SECTION	COUNTY	TOTAL SHEETS	SHEET NO.
	PLOT SCALE = 50.800 / IN.	DRAWN -	REVISED - T. RAMMACHER 03-12-99		350	50-1 VB-1-BR	COOK	33	29		
PLOT DATE = 1/4/2008	CHECKED -	REVISED - T. RAMMACHER 01-06-00	<b>RAISED REFLECTIVE PAVEMENT MARKERS (SNOW-PLOW RESISTANT)</b>		<b>TC-11</b>		<b>CONTRACT NO.</b>				
	DATE -	REVISED -	SCALE: NONE		SHEET NO. 1 OF 1 SHEETS	STA.	TO STA.	FED. ROAD DIST. NO. 1   ILLINOIS   FED. AID PROJECT			

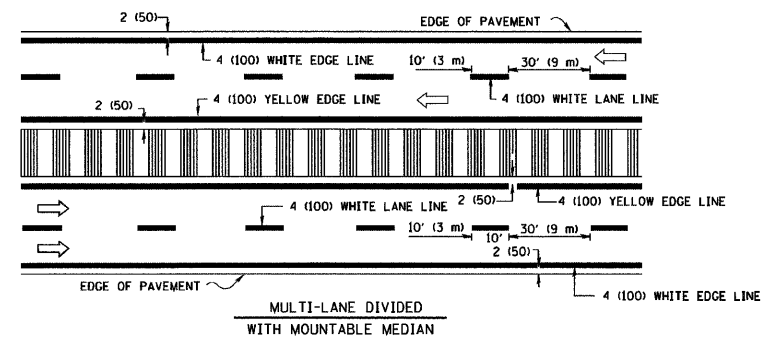
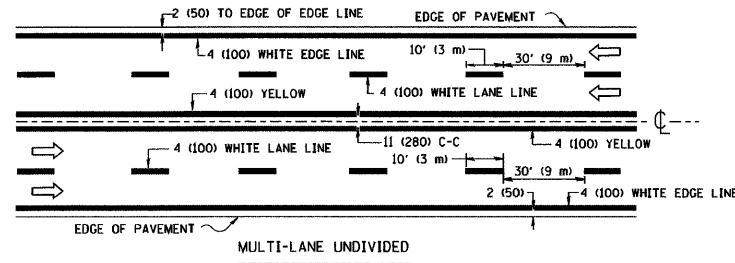
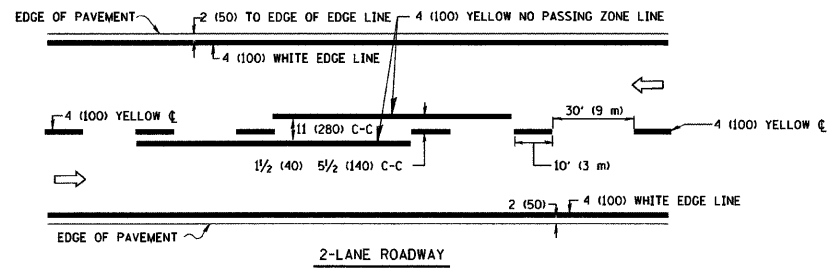

NOTE: MEDIANS WITH BARRIER CURB DO NOT REQUIRE AN EDGE LINE

**TYPICAL LANE AND EDGE LINE MARKING**

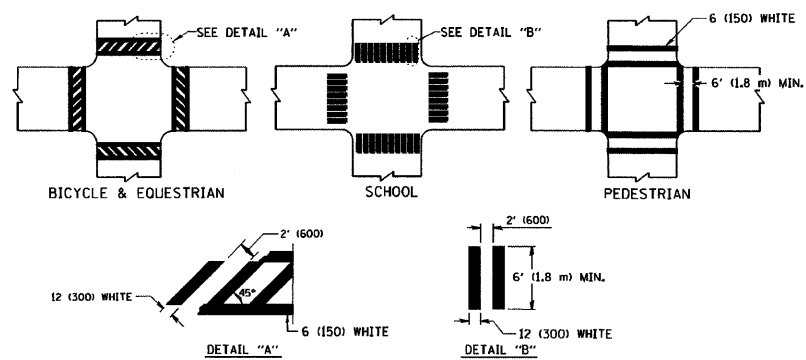

**TYPICAL CROSSWALK MARKING**

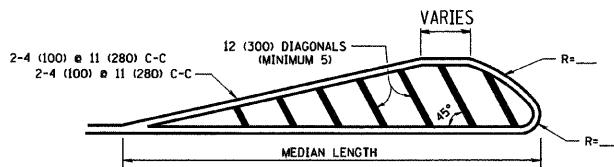
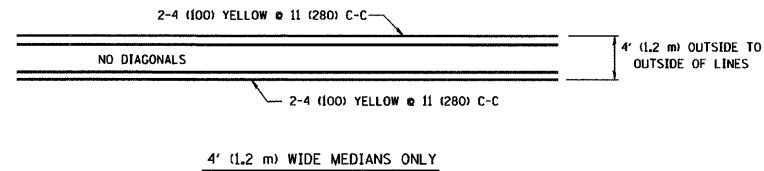

FOR MEDIAN LENGTHS WHERE DIAGONAL SPACING CANNOT BE ATTAINED, USE 5 (FIVE) EQUALLY SPACED DIAGONAL LINES.  
 DIAGONAL LINE SPACING: 50' (15 m) C-C (LESS THAN 30MPH (50 km/h))  
 75' (25 m) C-C 30MPH (50 km/h) TO 45MPH (70 km/h)  
 150' (45 m) C-C (MORE THAN 45MPH (70 km/h))

**MEDIANS OVER 4' (1.2 m) WIDE**

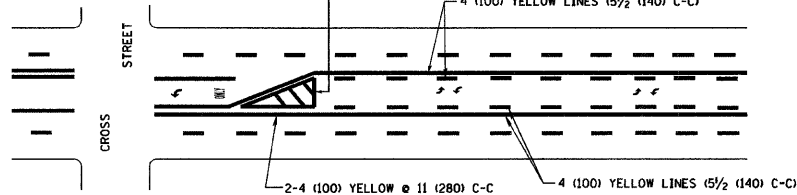

A MINIMUM OF TWO PAIRS OF TURN ARROWS SHALL BE USED, WHITE IN COLOR. ADDITIONAL PAIRS SHALL BE PLACED AT 200' (60 m) TO 300' (90 m) INTERVALS.

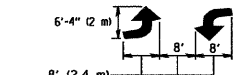

**MEDIAN WITH TWO-WAY LEFT TURN LANE**

**TYPICAL PAINTED MEDIAN MARKING**

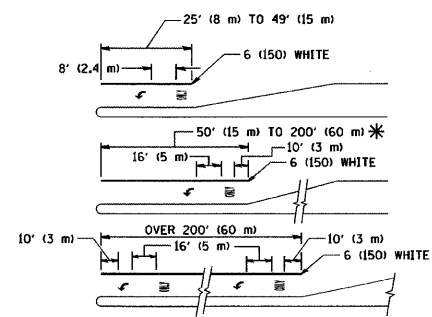

FULL SIZE LETTERS 8' (2.4 m) AND ARROWS SHALL BE USED.  
 AREA = 15.6 SQ. FT. (1.5 m<sup>2</sup>) AREA = 20.8 SQ. FT. (1.9 m<sup>2</sup>)

\* TURN LANES IN EXCESS OF 400' (120 m) IN LENGTH MAY HAVE AN ADDITIONAL SET OF ARROW - "ONLY" INSTALLED MIDWAY BETWEEN THE OTHER TWO SETS OF ARROW - "ONLY".

**TYPICAL LEFT (OR RIGHT) TURN LANE**

**TYPICAL TURN LANE MARKING**

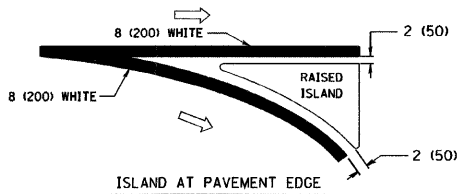
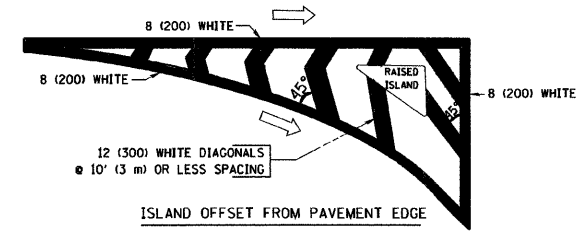

**TYPICAL ISLAND MARKING**

TYPE OF MARKING	WIDTH OF LINE	PATTERN	COLOR	SPACING / REMARKS
CENTERLINE ON 2 LANE PAVEMENT	4 (100)	SKIP-DASH	YELLOW	10' (3 m) LINE WITH 30' (9 m) SPACE
CENTERLINE ON MULTI-LANE UNDIVIDED PAVEMENT	2 @ 4 (100)	SOLID	YELLOW	11 (280) C-C
NO PASSING ZONE LINES FOR ONE DIRECTION FOR BOTH DIRECTIONS	4 (100) 2 @ 4 (100)	SOLID SOLID	YELLOW YELLOW	5/2 (140) C-C FROM SKIP-DASH CENTERLINE 11 (280) C-C OMIT SKIP-DASH CENTERLINE BETWEEN
LANE LINES	4 (100) 5 (125) ON FREEWAYS	SKIP-DASH SKIP-DASH	WHITE WHITE	10' (3 m) LINE WITH 30' (9 m) SPACE
DOTTED LINES (EXTENSIONS OF CENTER, LANE OR TURN LANE MARKINGS)	SAME AS LINE BEING EXTENDED	SKIP-DASH	SAME AS LINE BEING EXTENDED	2' (600) LINE WITH 6' (1.8 m) SPACE
EDGE LINES	4 (100)	SOLID	YELLOW-LEFT WHITE-RIGHT	OUTLINE MOUNTABLE MEDIANS IN YELLOW; EDGE LINES ARE NOT USED NEXT TO BARRIER CURB
TURN LANE MARKINGS	6 (150) LINES; FULL SIZE LETTERS & SYMBOLS (8' (2.4m))	SOLID	WHITE	SEE TYPICAL TURN LANE MARKING DETAIL
TWO WAY LEFT TURN MARKING	2 @ 4 (100) EACH DIRECTION 8' (2.4m) LEFT ARROW	SKIP-DASH AND SOLID IN PAIRS	YELLOW WHITE	10' (3 m) LINE WITH 30' (9 m) SPACE FOR SKIP-DASH; 5/2 (140) C-C BETWEEN SOLID LINE AND SKIP-DASH LINE SEE TYPICAL TWO-WAY LEFT TURN MARKING DETAIL
CROSSWALK LINES (PEDESTRIAN) A. DIAGONALS (BIKE & EQUESTRIAN) B. LONGITUDINAL BARS (SCHOOL)	2 @ 6 (150) 12 (300) @ 45° 12 (300) @ 90°	SOLID SOLID SOLID	WHITE WHITE WHITE	NOT LESS THAN 6' (1.8 m) APART 2' (600) APART SEE TYPICAL CROSSWALK MARKING DETAILS.
STOP LINES	24 (600)	SOLID	WHITE	PLACE 4' (1.2 m) IN ADVANCE OF AND PARALLEL TO CROSSWALK, IF PRESENT. OTHERWISE, PLACE AT DESIRED STOPPING POINT, PARALLEL TO CROSSROAD CENTERLINE, WHERE POSSIBLE
PAINTED MEDIANS	2 @ 4 (100) WITH 12 (300) DIAGONALS @ 45° NO DIAGONALS USED FOR 4' (1.2 m) WIDE MEDIANS	SOLID	YELLOW; TWO WAY TRAFFIC WHITE; ONE WAY TRAFFIC	11 (280) C-C FOR THE DOUBLE LINE SEE TYPICAL PAINTED MEDIAN MARKING.
GORE MARKING AND CHANNELIZING LINES	8 (200) WITH 12 (300) DIAGONALS @ 45°	SOLID	WHITE	DIAGONALS: 15' (4.5 m) C-C (LESS THAN 30MPH (50 km/h)) 20' (6 m) C-C 30MPH (50 km/h) TO 45MPH (70 km/h) 30' (9 m) C-C (OVER 45MPH (70 km/h))
RAILROAD CROSSING	24 (600) TRANSVERSE LINES; "RR" 15 6' (1.8 m) LETTERS; 16 (400) LINE FOR "X"	SOLID	WHITE	SEE STATE STANDARD 78001 AREA OF: "R"=3.6 SQ. FT. (0.33 m <sup>2</sup> ) EACH "X"=54.0 SQ. FT. (5.0 m <sup>2</sup> )
SHOULDER DIAGONALS	12 (300) @ 45°	SOLID	WHITE - RIGHT YELLOW - LEFT	50' (15 m) C-C (LESS THAN 30MPH (50 km/h)) 75' (25 m) C-C 30 MPH (50 km/h) TO 45MPH (70 km/h) 150' (45 m) C-C (OVER 45MPH (70 km/h))

FOR FURTHER DETAILS ON PAVEMENT MARKING REFER TO STANDARD SPECIFICATIONS FOR ROAD AND BRIDGE CONSTRUCTION AND STATE STANDARD 780001.

All dimensions are in inches (millimeters) unless otherwise shown.

FILE NAME = W:\dststd\22x34\td13.dgn	USER NAME = gaglianobt	DESIGNED - EVERS	REVISED - T. RAMMACHER 10-27-94
		DRAWN -	REVISED - A. HOUSEH 10-09-96
	PLOT SCALE = 50,000 / IN.	CHECKED -	REVISED - A. HOUSEH 10-17-96
	PLOT DATE = 1/4/2008	DATE - 03-19-90	REVISED - T. RAMMACHER 01-06-00

**STATE OF ILLINOIS  
DEPARTMENT OF TRANSPORTATION**

DISTRICT ONE		F.A.P. R.T.E.	SECTION	COUNTY	TOTAL SHEETS	SHEET NO.
TYPICAL PAVEMENT MARKINGS		350	50-1 VB-1-BR	COOK	33	30
SCALE: NONE		SHEET NO. 1 OF 1 SHEETS		STA. TO STA.	CONTRACT NO.	

TC-13		FED. ROAD DIST. NO. 1	ILLINOIS	FED. AID PROJECT
-------	--	-----------------------	----------	------------------

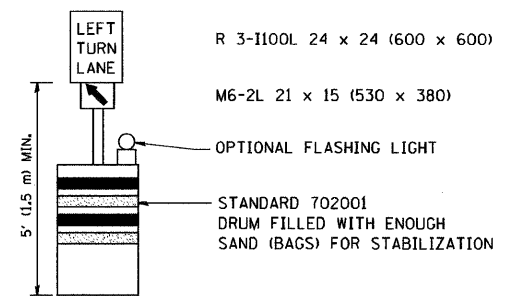
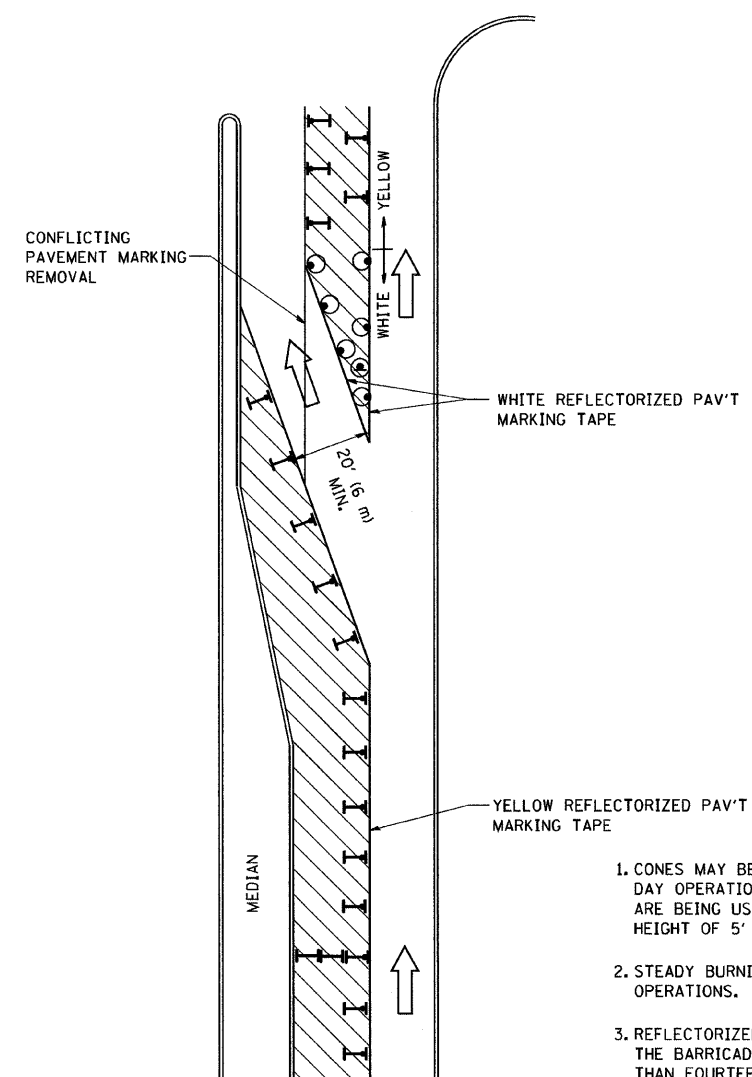

**GENERAL NOTES**

1. CONES MAY BE SUBSTITUTED FOR BARRICADES OR DRUMS AT HALF THE SPACING DURING DAY OPERATIONS. CONES SHALL BE A MINIMUM OF 28 (710) IN HEIGHT. WHEN CONES ARE BEING USED, THE "LEFT TURN LANE" SIGN MAY BE SKID MOUNTED AT A MINIMUM HEIGHT OF 5' (1.5 m).
2. STEADY BURNING LIGHTS WILL NOT BE REQUIRED ON BARRICADES OR DRUMS FOR DAY OPERATIONS. ALL LIGHTS SHALL BE MONODIRECTIONAL.
3. REFLECTORIZED TEMPORARY PAVEMENT MARKING TAPE SHALL BE PLACED THROUGHOUT THE BARRICADED AREA OF EACH TURN BAY WHERE THE CLOSURE TIME IS GREATER THAN FOURTEEN DAYS.
4. THIS APPLICATION ALSO APPLIES WHEN WORK IS BEING PERFORMED IN THE RIGHT LANE(S) AND THE RIGHT TURN BAY IS TO REMAIN OPEN. UNDER THIS CONDITION, "RIGHT TURN LANE" R3-100 24 x 24 (600 x 600) AND M6-2R 21 x 15 (530 x 380) SHALL BE USED.
5. THESE CONTROLS SHALL SUPPLEMENT MAINLINE TRAFFIC CONTROL FOR LANE CLOSURES.
6. LONGITUDINAL DIMENSIONS MAY BE ADJUSTED TO FIT FIELD CONDITIONS.
7. FORM BT 725 IS REQUIRED.
8. TRAFFIC CONTROL AND PROTECTION AT TURN BAYS (TO REMAIN OPEN TO TRAFFIC) SHALL BE INCLUDED IN THE COST SPECIFIED TRAFFIC CONTROL STANDARDS OR ITEMS.

All dimensions are in inches (millimeters) unless otherwise shown.

**LEGEND**

- WORK AREA
- LANE OPEN TO TRAFFIC
- TYPE I OR II BARRICADE WITH STEADY BURN LIGHT
- DRUM WITH STEADY BURN LIGHT
- DRUM WITH SIGN (WITH OPTIONAL FLASHING LIGHT) SEE DETAIL
- TYPE I OR II CHECK BARRICADE WITH FLASHING LIGHT

FILE NAME = W:\dststd\22x34\tc14.dgn	USER NAME = gaglianobt	DESIGNED -	REVISED -T. RAMMACHER 09-08-94
		DRAWN -	REVISED - A. HOUSEH 11-07-95
		CHECKED -	REVISED - A. HOUSEH 10-12-96
		DATE -	REVISED -T. RAMMACHER 01-06-00

**STATE OF ILLINOIS  
DEPARTMENT OF TRANSPORTATION**

**TRAFFIC CONTROL AND PROTECTION AT TURN BAYS  
(TO REMAIN OPEN TO TRAFFIC)**

SCALE: NONE SHEET NO. 1 OF 1 SHEETS STA. TO STA.

F.A.P. RTE.	SECTION	COUNTY	TOTAL SHEETS	SHEET NO.
350	50-1 VB-1-BR	COOK	33	31
TC-14			CONTRACT NO.	
FED. ROAD DIST. NO. 1 [ILLINOIS] FED. AID PROJECT				

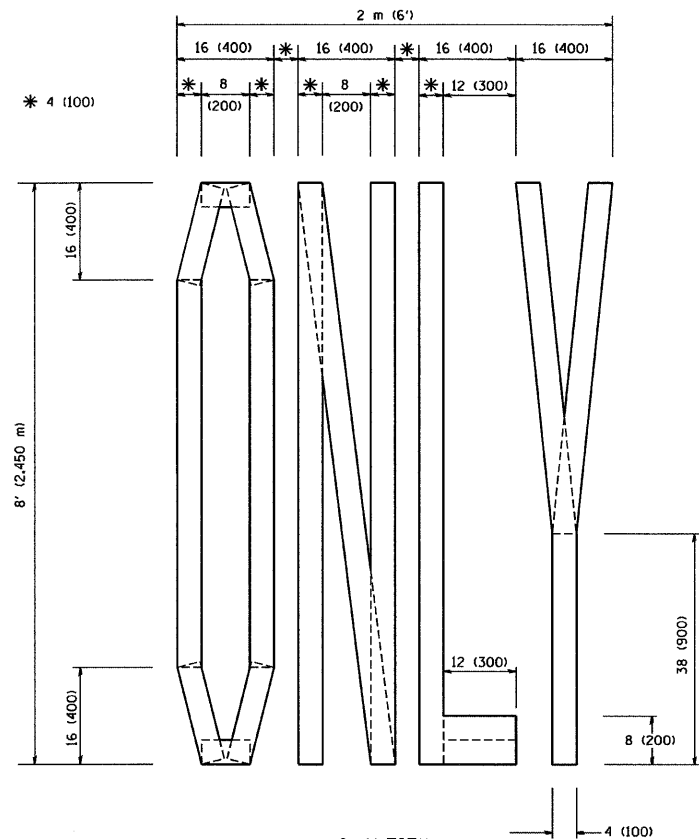

QUANTITY  
 4 (100) LINE = 64.1 ft. (19.7 m)  
 21.1 sq. ft. (1.97 sq. m)

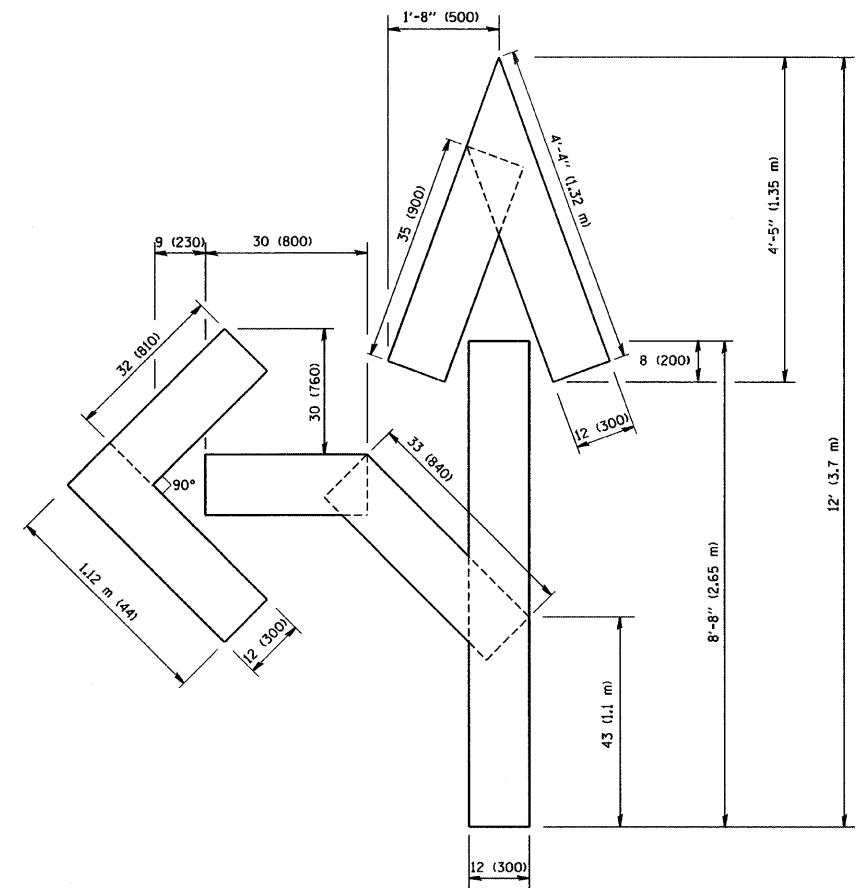

QUANTITY  
 4 (100) LINE = 82.5 ft. (25.3 m)  
 27.5 sq. ft. (2.53 sq. m)

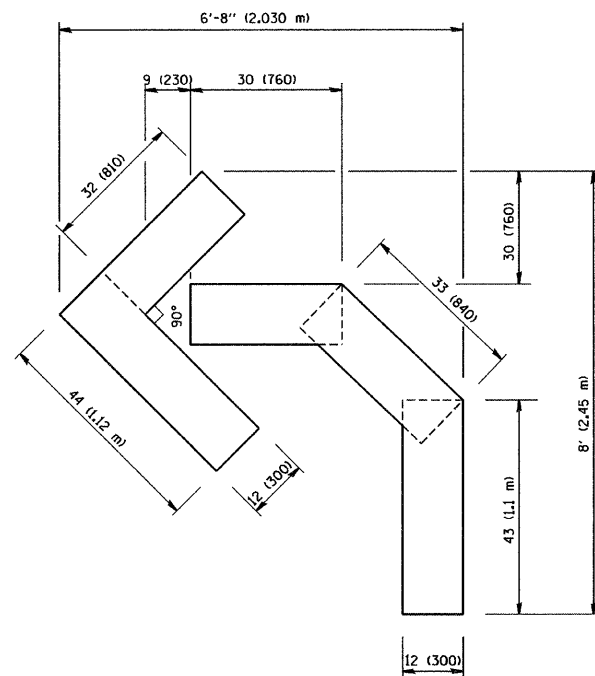

QUANTITY  
 4 (100) LINE = 45.5 ft. (13.9 m)  
 15.2 sq. ft. (1.39 sq. m)

All dimensions are in inches (millimeters) unless otherwise shown.

FILE NAME = W:\dststd\22x34\tc16.dgn	USER NAME = gaglionobt	DESIGNED -	REVISED -T. RAMMACHER 06-05-96
		DRAWN -	REVISED -T. RAMMACHER 11-04-97
	PLOT SCALE = 50.0000 / IN.	CHECKED -	REVISED -T. RAMMACHER 03-02-98
	PLOT DATE = 1/4/2008	DATE - 09-18-94	REVISED -E. GOMEZ 08-28-00

STATE OF ILLINOIS  
 DEPARTMENT OF TRANSPORTATION

PAVEMENT MARKING LETTERS AND SYMBOLS  
 FOR TRAFFIC STAGING

SCALE: NONE SHEET NO. 1 OF 1 SHEETS STA. TO STA.

F.A.P. RTE. 350	SECTION 50-1 VB-1-BR	COUNTY COOK	TOTAL SHEETS 33	SHEET NO. 32
TC-16			CONTRACT NO.	
FED. ROAD DIST. NO. 1 ILLINOIS FED. AID PROJECT				



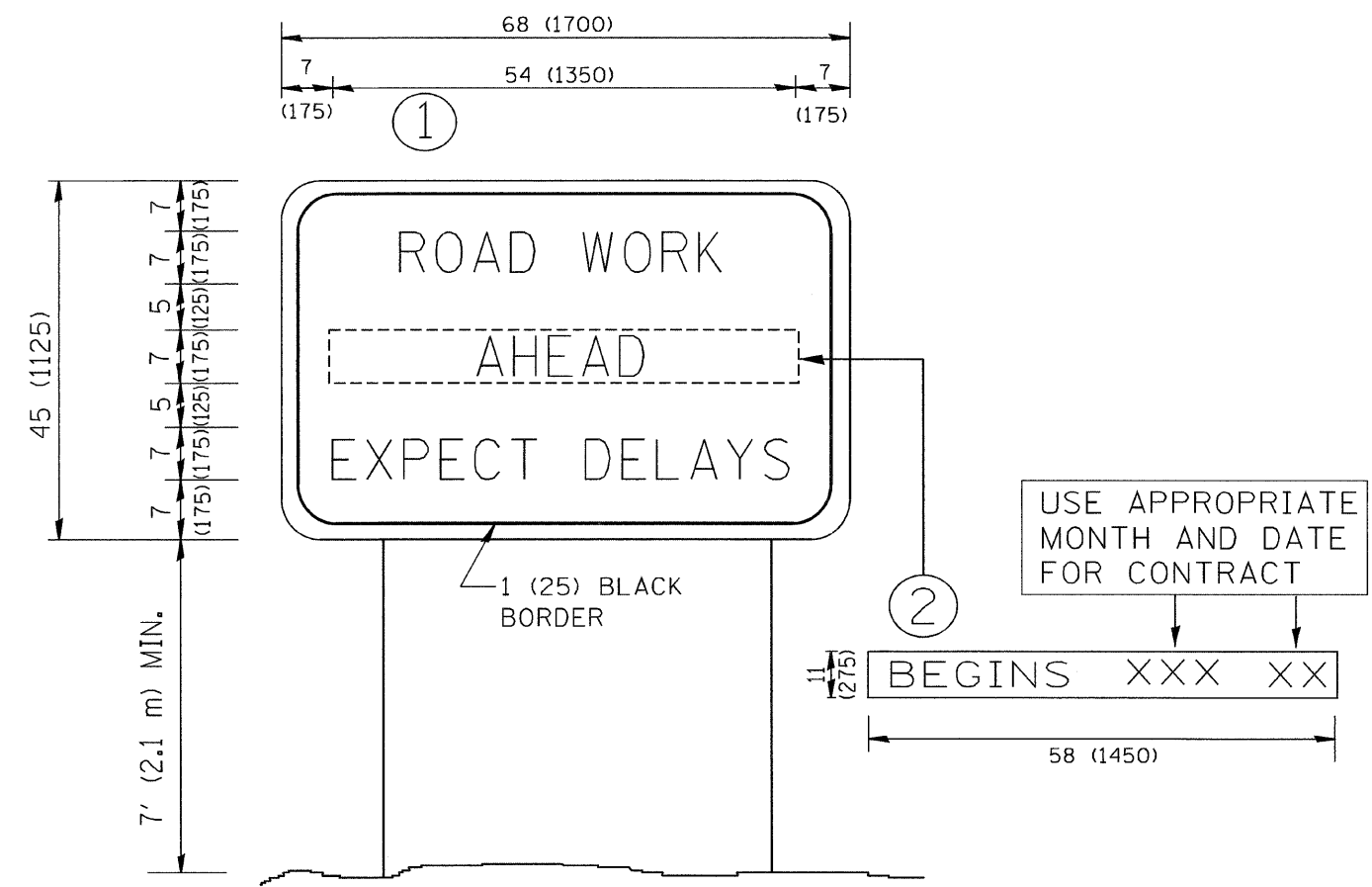

**NOTES:**

1. USE BLACK LETTERING ON ORANGE BACKGROUND.
2. ERECT SIGNS IN ADVANCE OF THE LOCATION FOR THE "ROAD CONSTRUCTION AHEAD" SIGN AT LOCATIONS AS DIRECTED BY THE ENGINEER.
3. ERECT SIGN ① WITH INSTALLED PANEL ② ONE WEEK PRIOR TO THE START OF CONSTRUCTION.
4. REMOVE PANEL ② SOON AFTER THE START OF CONSTRUCTION.
5. SEE SPECIAL PROVISION FOR "TEMPORARY INFORMATION SIGNING" FOR ADDITIONAL INFORMATION.
6. ONE SIGN ASSEMBLY EQUALS 25.70 SQ. FT. (2.3 SQ. M.)
7. SHALL BE PAID FOR AS TEMPORARY INFORMATION SIGNING.

ALL DIMENSIONS ARE IN INCHES (MILLIMETERS) UNLESS OTHERWISE SHOWN.

FILE NAME = W:\dststd\22x34\to22.dgn	USER NAME = goglianobt	DESIGNED -	REVISED - R. MIRS 09-15-97	<b>STATE OF ILLINOIS DEPARTMENT OF TRANSPORTATION</b>	<b>ARTERIAL ROAD INFORMATION SIGN</b>	F.A.P. RTE.	SECTION	COUNTY	TOTAL SHEETS	SHEET NO.	
		DRAWN -	REVISED - R. MIRS 12-11-97			350	50-1 VB-1-BR	COOK	33	33	
		CHECKED -	REVISED - T. RAMMACHER 02-02-99			<b>TC-22</b>		<b>CONTRACT NO.</b>			
		DATE -	REVISED - C. JUCIUS 01-31-07			SCALE: NONE	SHEET NO. 1 OF 1 SHEETS	STA.	TO STA.	FED. ROAD DIST. NO. 1   ILLINOIS   FED. AID PROJECT	