

## SEQUENCE OF OPERATIONS (3 LANE SECTION)

### OPERATION 1 (3 LANE SECTION)

RESURFACING WORK IN OPERATION 1 SHALL CONSISTS OF MILLING THE OUTSIDE SHOULDER 3 3/4", THEN MILLING THE OUTSIDE LANE (LANE 3) 2". AT THE END OF THE NIGHT A 5" EPOXY SKIP DASH LANE LINE SHALL BE PLACED IN BETWEEN LANE 2 AND LANE LANE 3.

### OPERATION 2 (3 LANE SECTION)

RESURFACING WORK IN OPERATION 2 SHALL CONSISTS OF MILLING LANE (1) 4" AND LANE (2) 2". THEN PLACING THE 2" SMA BINDER ON LANES 1. AT THE END OF THE NIGHT A 5" WET REFLECTIVE TEMPORARY TAPE SKIP DASH LANE LINE SHALL BE PLACED IN BETWEEN LANE 1 AND LANE 2.

### OPERATION 3 (3 LANE SECTION)

RESURFACING WORK IN OPERATION 3 SHALL CONSIST OF MILLING LANE 3 AN ADDITIONAL 2". AT THE END OF THE NIGHT A 5" EPOXY SKIP DASH LANE LINE SHALL BE PLACED IN BETWEEN LANE 2 AND LANE 3.

### OPERATION 4 (3 LANE SECTION)

RESURFACING WORK IN OPERATION 4 SHALL CONSIST OF MILLING LANE 2 AN ADDITIONAL 2". THEN PLACING 2" SMA BINDER ON LANE 2.

### OPERATION 5 (3 LANE SECTION)

RESURFACING WORK IN OPERATION 5 SHALL CONSIST OF PLACING THE 2" SMA BINDER ON LANE 3 AND 2 1/4" BINDER ON THE OUTSIDE SHOULDER. AT THE END OF THE NIGHT A 5" WET REFLECTIVE TEMPORARY TAPE, TYPE III SKIP DASH LANE LINE SHALL BE PLACED IN BETWEEN LANE 2 AND LANE 3.

### OPERATION 6 (3 LANE SECTION)

RESURFACING WORK IN OPERATION 6 SHALL CONSIST OF PLACING THE 2" SMA SURFACE ON LANE 1 AND LANE 2. AT THE END OF THE NIGHT THE 4" THERMOPLASTIC EDGE LINE SHALL BE PLACED ON THE INSIDE EDGE OF LANE 1. ALSO THE PERMANENT 5" PREFORMED PLASTIC PAVEMENT MARKING SKIP DASH LANE LINE SHALL BE PLACED BETWEEN LANES 1 AND 2, AND BETWEEN LANES 2 AND 3.

### OPERATION 7 (3 LANE SECTION)

RESURFACING WORK IN OPERATION 7 SHALL CONSIST OF PLACING THE 2" SMA SURFACE ON LANE 3 AND PLACING THE 1 1/2" SURFACE ON THE OUTSIDE SHOULDER. AT THE END OF THE NIGHT THE THERMOPLASTIC EDGE LINE SHALL BE PLACED AT THE OUTSIDE EDGE OF LANE 3.

## SEQUENCE OF OPERATIONS (3 LOCAL LANES SECTION)

### OPERATION 1

RESURFACING WORK IN OPERATION 1 SHALL CONSISTS OF MILLING THE OUTSIDE SHOULDER 3 3/4", THEN MILLING LANES 2, 3, & 4 2". AT THE END OF THE NIGHT A 5" EPOXY SKIP DASH LANE LINE SHALL BE PLACED IN BETWEEN LANE 1 & 2, LANE 2 & 3, AND LANE 3 & 4.

### OPERATION 2

RESURFACING WORK IN OPERATION 2 SHALL CONSISTS OF MILLING LANE (1) 2" AND THE SHOULDER 3 3/4".

### OPERATION 3

RESURFACING WORK IN OPERATION 3 SHALL CONSIST OF MILLING LANES 2, 3 & 4 AN ADDITIONAL 2". AT THE END OF THE NIGHT A 5" EPOXY SKIP DASH LANE LINE SHALL BE PLACED.

### OPERATION 4

RESURFACING WORK IN OPERATION 4 SHALL CONSIST OF MILLING LANE 1 AN ADDITIONAL 2".

### OPERATION 5

RESURFACING WORK IN OPERATION 5 SHALL CONSIST OF PLACING THE 2" SMA BINDER ON LANE 4, AND THE 2 1/4" BINDER ON THE OUTSIDE SHOULDER. AT THE END OF THE NIGHT A 5" WET REFLECTIVE TEMPORARY TAPE, TYPE III SKIP DASH LANE LINE SHALL BE PLACED IN BETWEEN LANE 3 AND LANE 4.

### OPERATION 6

RESURFACING WORK IN OPERATION 6 SHALL CONSIST OF PLACING THE 2" SMA BINDER ON LANE 3. AT THE END OF THE NIGHT A 5" WET REFLECTIVE TEMPORARY TAPE, TYPE III SKIP DASH LANE LINE SHALL BE PLACED IN BETWEEN LANE 2 AND LANE 3.

### OPERATION 7

RESURFACING WORK IN OPERATION 7 SHALL CONSIST OF PLACING THE 2" SMA BINDER ON LANE 2. AT THE END OF THE NIGHT A 5" WET REFLECTIVE TEMPORARY TAPE, TYPE III SKIP DASH LANE LINE SHALL BE PLACED IN BETWEEN LANE 1 AND LANE 2.

### OPERATION 8

RESURFACING WORK IN OPERATION 8 SHALL CONSIST OF PLACING THE 2" SMA BINDER ON LANE 1 AND THE 2 1/4 BINDER ON THE INSIDE SHOULDER.

REPEAT OPERATION 5 THRU 8 FOR SURFACE COURSE AND PLACE PERMANENT MARKINGS AND REFLECTORS AS SHOWN ON PLANS.

SAME SEQUENCE CAN BE USED TO RESURFACE EXPRESS LANES.

## NOTES

THE CONTRACTOR SHALL REPAIR LONGITUDINAL JOINTS AS DIRECTED BY THE RESIDENT ENGINEER PRIOR TO STAGING ANY WORK. THE CONTRACTOR SHALL REPAIR THE JOINT WITH A 2 FT WIDE, 2" DEEP MILL AND FILL WITH HOT-MIX ASPHALT SURFACE COURSE, MIX "D", N70.

PATCHING SHALL PRECEDE MILLING OPERATIONS.

THE CONTRACTOR SHALL START MILLING & RESURFACING OPERATIONS AT THE NORTH END OF THE JOB, AND PROCEED SOUTHWARD.

TRAFFIC WILL NOT BE ALLOWED ON THE MILLED SURFACE ON LANE 1 ADJACENT TO THE CONCRETE SHOULDER. CONTRACTOR SHALL PLACE BINDER THE SAME NIGHT AS THE MILLING OPERATION.

THE CONTRACTOR SHALL STAGE RESURFACING OPERATIONS SUCH THAT THE CROSS SLOPE FROM THE CROWN OF THE ROADWAY TO THE OUTSIDE EDGE OF THE SHOULDER WILL NOT TRAP WATER ON OPEN TRAFFIC LANES.

THE CONTRACTOR SHALL PLACE AND MAINTAIN DRUMS WITH MONO-DIRECTIONAL STEADY BURNING LIGHTS AT 100 FOOT C-C ON THE SHOULDER ADJACENT TO MILLED AREAS, DRUMS WILL REMAIN IN PLACE UNTIL THE PROPOSED SURFACE HAS BEEN PLACED AND THE PERMANENT EDGE LINES HAVE BEEN INSTALLED.

AT THE END OF EACH NIGHTLY SHIFT, THE CONTRACTOR SHALL SWEEP THE PAVEMENT SURFACE CLEAN, PLACE TEMPORARY PAVEMENT MARKINGS, AND REMOVE TRAFFIC CONTROL FOR THE LANE CLOSURE. ONLY THE 5" SKIPS-DASH LANE LINES AND THE 8" GORE MARKINGS AT RAMPS ARE REQUIRED FOR THE TEMPORARY PAVEMENT MARKINGS

GRADE DIFFERENTIAL BETWEEN PAVED LANES SHALL NOT EXCEED 2".

THE MILLING REQUIRED TO PLACE A TAPER BETWEEN LANES WILL BE INCLUDED IN THE COST OF HOT-MIX ASPHALT SURFACE REMOVAL 4" & HOT MIX ASPHALT SURFACE REMOVAL, 3 3/4".

SINCE THIS IS AN EXPRESSWAY FACILITY, THE CONTRACTOR MAY HAVE CREWS WORKING IN THE NORTHBOUND AND SOUTHBOUND DIRECTIONS AT THE SAME TIME.

PARTIAL MILLING OF THE MAINLINE PAVEMENT FOR EACH OPERATION WILL NOT BE PAID FOR SEPARATELY (2" AND 2" MILLING), BUT WILL BE PAID FOR AT THE FINAL ITEM OF MILLING THICKNESS AS SHOWN ON THE PLANS.

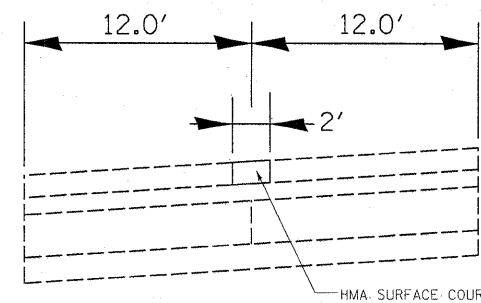
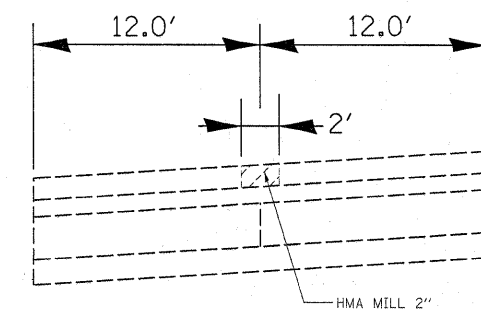

## LONGITUDINAL JOINT REPAIR

FILE NAME =	USER NAME = abreuah	DESIGNED -	REVISED -	<b>STATE OF ILLINOIS DEPARTMENT OF TRANSPORTATION</b>	<b>I-290/ILL 53 FROM ILL 72 TO US 12 SUGGESTED SEQUENCE OF OPERATIONS</b>	F.A. RTE.	SECTION	COUNTY	TOTAL SHEETS	SHEET NO.
c:\pwwork\FWIDOT\ABREUAH\0166689\010310-Design.dgn	DRAWN -	REVISED -	290			(531-3.1, 0305-302 K)	COOK	314	6	
PLDT SCALE = 50.0000' / IN.	CHECKED -	REVISED -	CONTRACT NO. 60138							
PLDT DATE = 2/11/2010	DATE -	REVISED -	SCALE:			SHEET NO.	OF SHEETS	STA.	TO STA.	ILLINOIS FED. AID PROJECT