

Existing Structure: SN 016-0665 is a 3 span 42" P.P.C. I Beam with an 8" concrete deck and a 1/2" HMA overlay with waterproofing. The substructure was built in 1929 and consists of closed abutments and solid piers. The current superstructure was added in 1980 as FAU Rte. 1350, Sec. 1977-189-BR, W, RS & TS and the substructure was widened. Scour countermeasures were added in 1999 and substructure repairs were done in 2003.

Stage construction will be utilized to maintain traffic during construction.

No salvage.

GENERAL NOTES

Reinforcement bars shall conform to the requirements of ASTM A 706 Gr 60. See Special Provisions.

Reinforcement bars designated (E) shall be epoxy coated.

Prior to pouring the new concrete deck, all heavy or loose rust, loose mill scale, and other loose or potentially detrimental foreign material shall be removed from the surfaces in contact with concrete. Removal shall be accomplished by methods that will not damage the concrete beam and the cost will be included in the pay item covering removal of the existing concrete.

Plan dimensions and details relative to existing plans are subject to nominal construction variations. The Contractor shall field verify existing dimensions and details affecting new construction and make necessary approved adjustments prior to construction or ordering of materials. Such variations shall not be cause for additional compensation for a change in scope of the work, however, the Contractor will be paid for the quantity actually furnished at the unit price bid for the work.

Concrete Sealer shall be applied to the parapets, sidewalks and median surfaces. All surfaces to be sealed shall be cleaned thoroughly prior to sealer application. Cost included with Concrete Sealer.

The Contractor shall exercise care during removal of existing joints to ensure that the slab and beams integrity will not be detrimentally impacted. The Contractor shall repair any damage(s) to the slab & beams caused by his operation as directed by the Engineer at no additional cost to the Department.

Protective Coat shall be applied to the new Bridge Deck Latex Concrete Overlay and slab at the expansion joints.

Joint openings shall be adjusted according to Article 520.04 of the Std. Specs. when the deck is poured at an ambient temperature other than 50°F.

Protective Shield required for deck repairs and joint reconstruction shall be installed according to Article 501.03 of the Standard Specifications and to the limits shown on this sheet.

SCOPE OF WORK

- 1 Bridge Deck Hydro - Scarification
- 2 Bridge Deck Repair
- 3 Reconstruct Expansion Joints with Preformed Joint Strip Seal
- 4 Eliminate longitudinal joint
- 5 Replace existing 4" x 12" deck drains with 6" ϕ deck drains
- 6 Place new 2 1/4" latex concrete overlay
- 7 Reseal relief joints at ends of approach pavement
- 8 Apply concrete sealer to parapets and sidewalks

TOTAL BILL OF MATERIAL

Item	Unit	Total
Hot Mix Asphalt Surface Removal (Deck)	Sq. Yd.	1134
Bridge Deck Hydro - Scarification 1/2"	Sq. Yd.	1134
Bridge Deck Latex Concrete Overlay, 2 1/4"	Sq. Yd.	1134
Concrete Removal	Cu. Yd.	75.4
Concrete Superstructure	Cu. Yd.	78.0
Reinforcement Bars, Epoxy Coated	Pound	12,480
Bar Splicers	Each	22
Preformed Joint Strip Seal	Foot	181
Floor Drains	Each	29
Concrete Sealer	Sq. Ft.	6950
Bridge Deck Grooving	Sq. Yd.	1064
Protective Coat	Sq. Yd.	1193
Clean and Reseal Relief Joint	Foot	150
Deck Slab Repair (Full Depth, Type I)	Sq. Yd.	7.5
Deck Slab Repair (Full Depth, Type II)	Sq. Yd.	10.0
Protective Shield	Sq. Yd.	1745

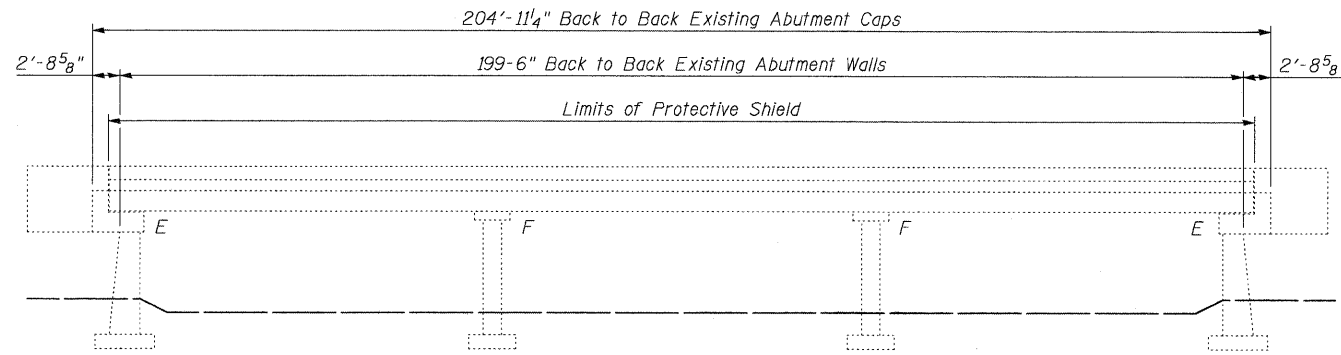

ELEVATION

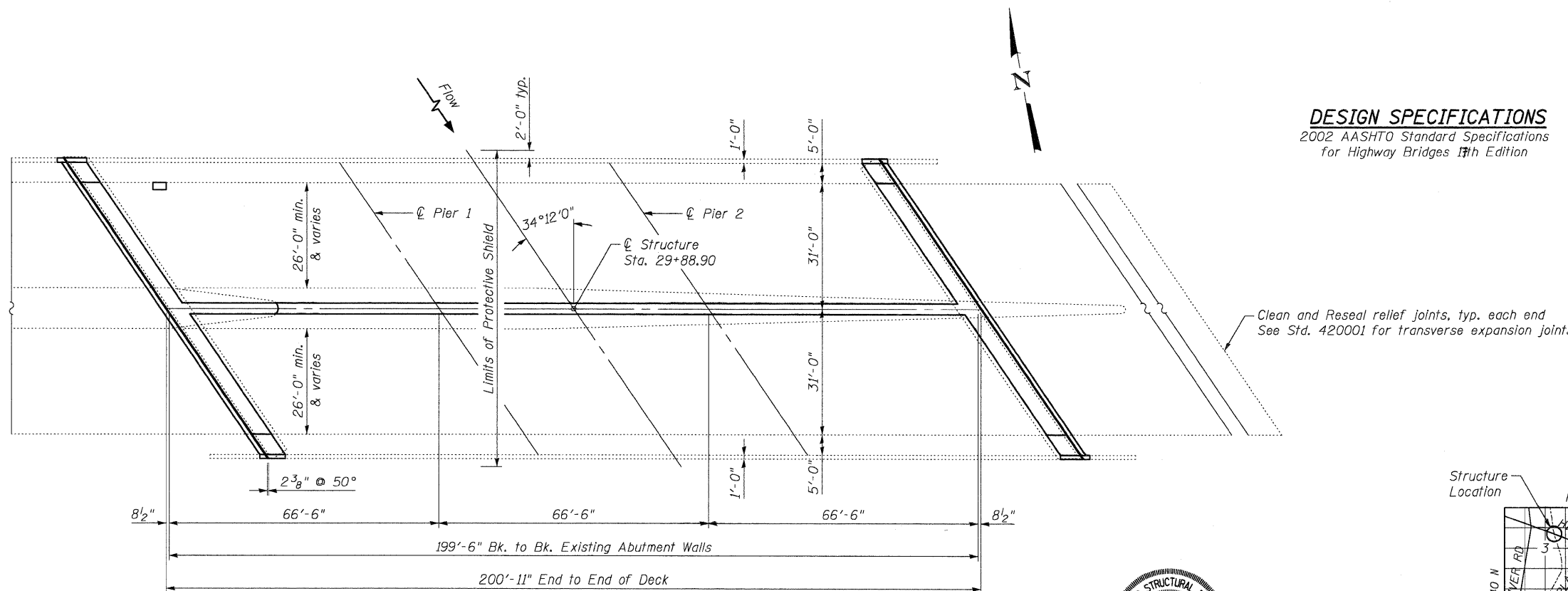

PLAN

DESIGN SPECIFICATIONS

2002 AASHTO Standard Specifications for Highway Bridges 17th Edition

DESIGN STRESSES (1977 Construction)

FIELD UNITS	PRECAST PRESTRESSED UNITS
f'c = 3,500 psi	f'c = 6,000 psi
fy = 60,000 psi	f'cl = 4,700 psi
	f's = 270,000 psi - 1/2" ϕ Strands
	f'sl = 189,000 psi - 1/2" ϕ Strands

INDEX OF SHEETS

- 1) General Plan and Elevation
- 2) Stage Construction Details
- 3) Concrete Removal Details
- 4) Deck Slab Repairs
- 5-6) Superstructure Details
- 7) Drain Details
- 8) Preformed Joint Strip Seal
- 9) Bar Splicer Assembly Details

**GENERAL PLAN AND ELEVATION
IL. RTE. 72 (HIGGINS ROAD) OVER
DES PLAINES RIVER
COOK COUNTY
STATION 29+88.90
STRUCTURE NO. 016-0665**

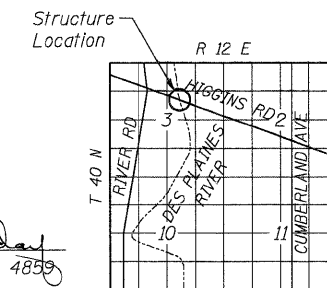

LOCATION SKETCH

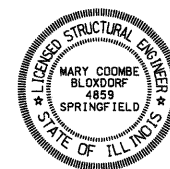

Mary Coombe Bloxdorf
ILLINOIS STRUCTURAL NO. 4889
EXPIRES 11/30/10
DATE: 2/12/10

CB Coombe-Bloxdorf P.C.
-CIVIL ENGINEERS-
-STRUCTURAL ENGINEERS-
-LAND SURVEYORS-
Design Firm License No. 184-002703

PROJECT NO. 07047-22
SCALE: / /
DATE: / /
DESIGN BY: MCB
DRAWN BY: CFC
CHECKED BY: MCB

SHEET NO. 1
9 SHEETS

F.A.U. RTE. 1350	SECTION 1292-1	COUNTY COOK	TOTAL SHEETS 33	SHEET NO. 17
CONTRACT NO. 60J57				
FED. ROAD DIST. NO. ILLINOIS FED. AID PROJECT				

PLOT DATE = 02/12/2010
 FILE NAME = 07047-22-01-general-plan.dgn
 PLOT SCALE = 1/8" = 1'-0"
 USER NAME = CFC