

EXISTING TYPICAL SECTION
LONG AVE. - STA. 87+73 TO STA. 94+25

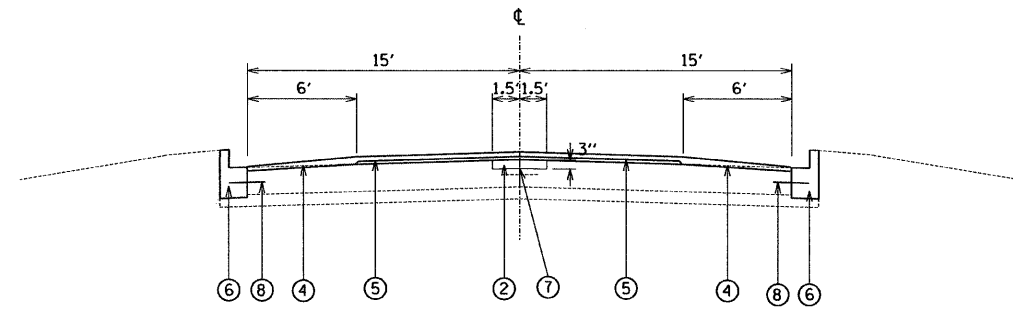

PROPOSED TYPICAL SECTION
LONG AVE. - STA. 87+73 TO STA. 94+25

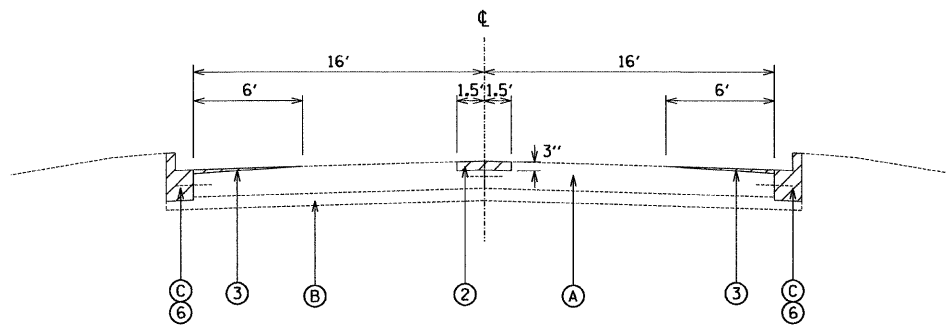

EXISTING TYPICAL SECTION
GREENWOOD AVE. - 81+19 TO STA. 87+73
CHASE AVE. - STA. 201+62 TO STA. 205+85
EAST FRONTAGE ROAD - STA. 217+00 TO 223+00

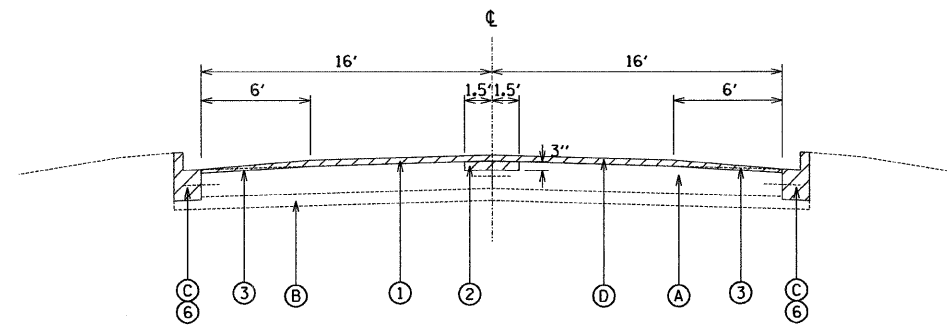

EXISTING TYPICAL SECTION

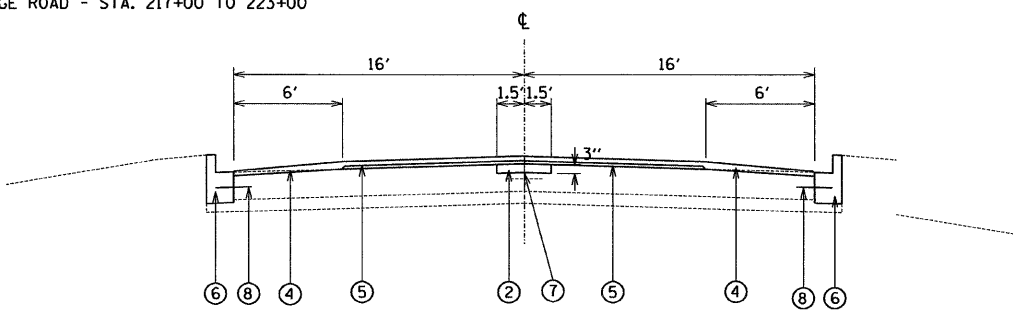

PROPOSED TYPICAL SECTION
GREENWOOD AVE. - 81+19 TO STA. 87+73
PARKSIDE AVE. - STA. 100+51 TO STA. 104+49
MAIN ST. - STA. 129+00 TO STA. 131+98
CENTRAL AVE. - STA. 171+00 TO STA. 184+29
CHASE AVE. - STA. 201+62 TO STA. 205+85
EAST FRONTAGE ROAD - STA. 217+00 TO 223+00

EXISTING CONDITIONS:

- (A) PCC PAVEMENT, 9"
- (B) GRANULAR SUB-BASE, 4"
- (C) COMBINATION CONCRETE CURB AND GUTTER, TYPE B-6.12
- (D) HOT-MIX ASPHALT SURFACE
- (E) AGGREGATE SHOULDER
- (Hatched) ITEMS TO BE REMOVED

PROPOSED IMPROVEMENTS:

- (1) HOT-MIX ASPHALT SURFACE REMOVAL, 2 1/2" (REMOVE TO P.C.C. PAVEMENT)
 - (2) PARTIAL DEPTH REMOVAL, 3" AND PARTIAL DEPTH PATCHING (HMA BINDER-19.0mm), 3"
 - (3) PCC SURFACE REMOVAL (PARTIAL DEPTH), 1 1/4" TO 0"
 - (4) HOT-MIX ASPHALT SURFACE COURSE, MIX "C", N50, 1 1/2"
 - (5) POLYMERIZED LEVELING BINDER (MACHINE METHOD), IL-4.75, N50, 1"
 - (6) COMBINATION CURB AND GUTTER REMOVAL AND REPLACEMENT (AS DETERMINED BY THE ENGINEER)
 - (7) STRIP REFLECTIVE CRACK CONTROL SYSTEM
 - (8) AGGREGATE WEDGE SHOULDER, TYPE B
 - (9) NO. 6 x 12" EPOXY COATED, DEFORMED TIE BARS AT 24" C-C (INCLUDED IN COST OF CURB AND GUTTER)
- SEE PLANS FOR PAVEMENT MARKING PLACEMENT.

n:\gs2009\28093823-24\road\site\dm\88\0160175-shh-yp\pccal2.dgn

FILE NAME =	USER NAME = .USER.	DESIGNED - AR	REVISED - RS 02-09-2010	STATE OF ILLINOIS DEPARTMENT OF TRANSPORTATION	I-94 FRONTAGE ROAD - WILLOW TO TOUHY TYPICAL SECTIONS		F.A.I. RTE.	SECTION	COUNTY	TOTAL SHEETS	SHEET NO.
	PLOT SCALE = 50.0000' / IN.	CHECKED - RS	REVISED -				94	2009-121 RS	COOK	25	5
PLOT DATE = 2/10/2010	DATE - 01/29/2010	REVISED -		SCALE: N/A S	SHEET NO. 1 OF 2 SHEETS	STA. TO STA.	ILLINOIS FED. AID PROJECT				