

STATE OF ILLINOIS  
DEPARTMENT OF TRANSPORTATION

\* Granular or solid flux filled headed studs conforming to Article 1006.32 of the Std. Specs., automatically end welded.

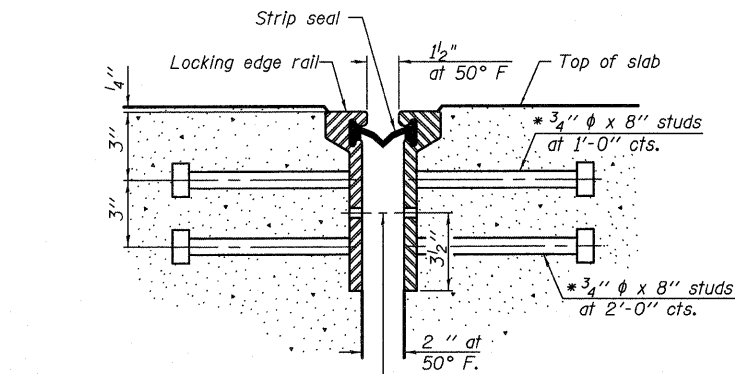

7/16" φ holes at 4'-0" cts. for 3/8" φ bolts. All bolts shall be burned, sawed, or chipped off flush with the plates after forms are removed, typ.

SECTION THRU  
ROLLED RAIL JOINT

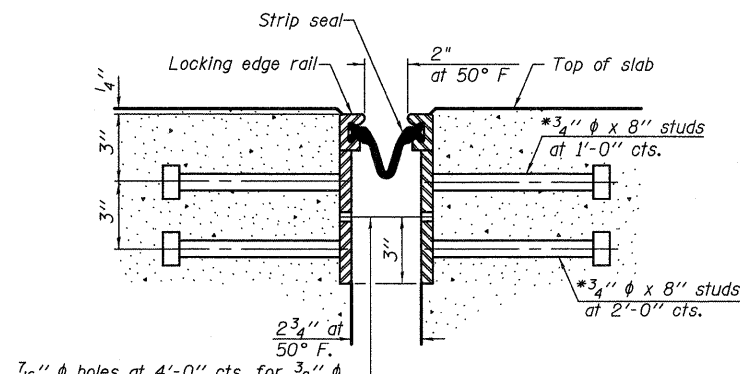

7/16" φ holes at 4'-0" cts. for 3/8" φ bolts. All bolts shall be burned, sawed, or chipped off flush with the plates after forms are removed, typ.

SECTION THRU  
WELDED RAIL JOINT

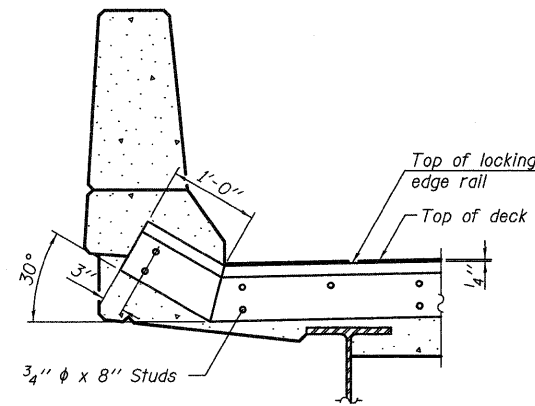

AT PARAPET

See Section A-A for end treatment of skews > 30°.

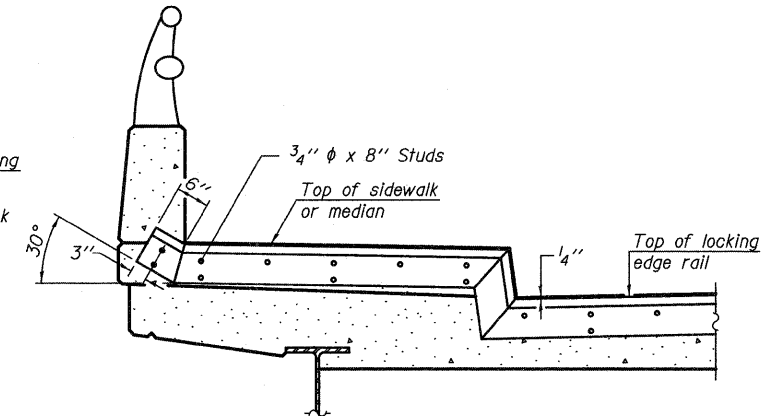

AT SIDEWALK OR MEDIAN

Shorter plates with a single row of studs at 12" cts. may be necessary on medians which are shallower than 9". See manufacturer's recommendation.

TYPICAL END TREATMENTS

Notes:

The strip seal shall be made continuous and shall have a minimum thickness of 1/4". The configuration of the strip seal shall match the configuration of the Locking Edge Rails. Open or "webbed" strip seal gland configurations are not permitted. The gland shall be sized for a maximum rated movement of 4 inches.

The Locking Edge Rails depicted are conceptual only, except for the minimum dimensions shown. The actual configuration of the Locking Edge Rails and matching strip seal may vary from manufacturer to manufacturer. Flanged edge rails will not be allowed. Locking Edge Rails may be spliced at slope discontinuities.

The manufacturer's recommended installation methods shall be followed. The joint opening and deck dimensions detailed on the superstructure are based on a rolled rail expansion joint. If the Contractor elects to use the welded rail expansion joint, the opening and deck dimensions shall be modified according to the dimensions detailed on this sheet. Required modifications shall be made at no additional cost to the State.

All steel components shall be galvanized after fabrication according to Article 520.03 of the Standard Specifications.

Maximum space between rail segments at stage lines shall be 3/16", sealed with a suitable sealant.

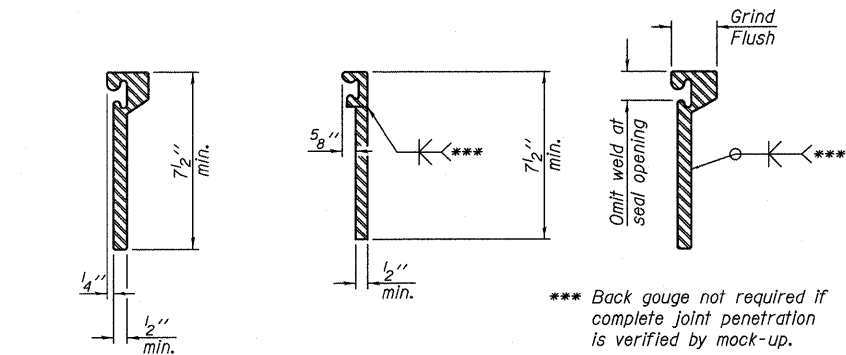

ROLLED  
EXTRUDED RAIL

WELDED RAIL

LOCKING EDGE  
RAIL SPLICE

The inside of the locking edge rail groove shall be free of weld residue. Rolled rail shown, welded rail similar.

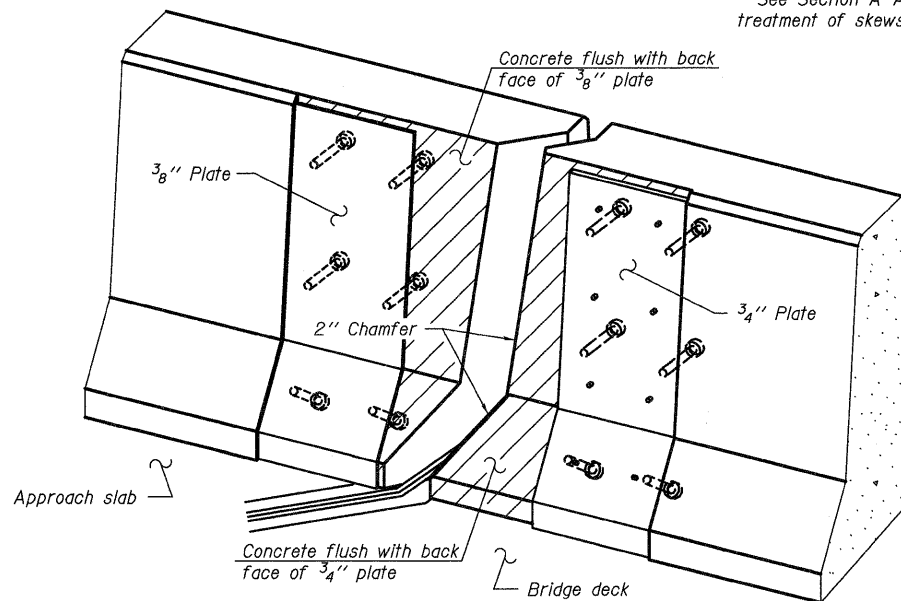

TRIMETRIC VIEW  
(Showing back plates only)

LOCKING EDGE RAILS

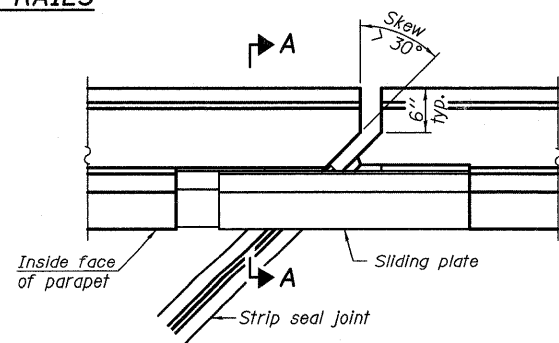

PLAN

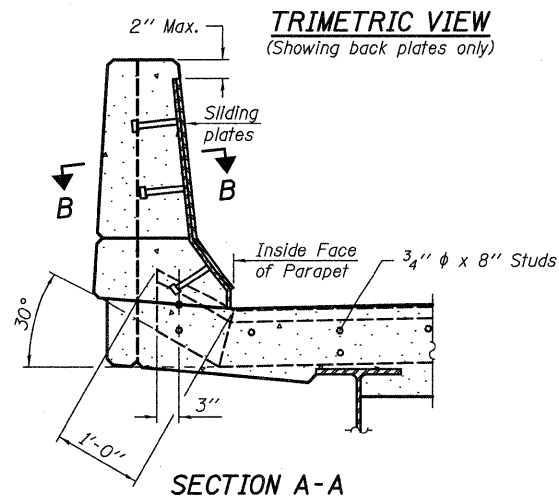

SECTION A-A

POINT BLOCK DETAILS  
(for skews > 30°)

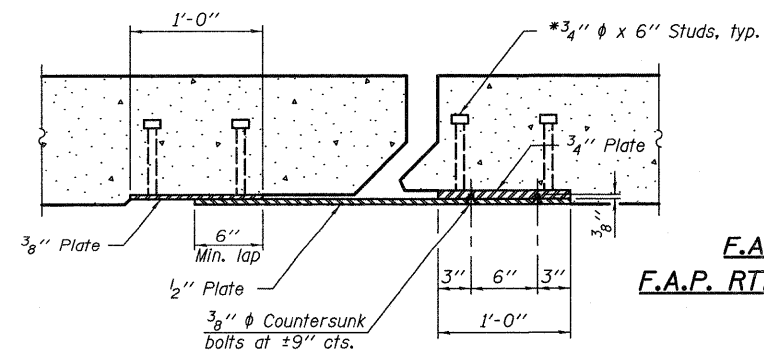

SECTION B-B

BILL OF MATERIAL

Item	Unit	Total
Preformed Joint Strip Seal	Foot	505

EXPANSION JOINT DETAILS

F.A.U. RTE. 2678 (YORK ROAD) OVER  
F.A.P. RTE. 347 (IL RTE. 38 - ROOSEVELT ROAD)

SECTION 163 HB-I-1

DUPAGE COUNTY

STATION 621+01.69

STRUCTURE NO. 022-0067

DESIGNED - CMV
CHECKED - SDS
DRAWN - DLH
CHECKED - CMV

**WHKS & CO.**  
ENGINEERING  
7018 KINGSMILL CT.,  
SPRINGFIELD, IL  
(217) 483-9457  
DESIGN FIRM #184001036

EJ-SSJ

11-1-09

SHEET NO. 12	F.A.U. RTE.	SECTION	COUNTY	TOTAL SHEETS	SHEET NO.
16 SHEETS	2678	163 HB-I-1	DUPAGE	31	22
C-91-275-10			CONTRACT NO. 60J85		
ILLINOIS FED. AID PROJECT					